

SB/LP/77 HOME

SEPTEMBER 1967

MODEL F 700 MK X HEADLAMP MODIFICATION

A different type of adjustment screw retainer is now being fitted to current versions of the F700 MK X headlamp (see fig.1).

The earlier type of retainer comprised a plastics interior, in which the adjustment screw could be rotated, and a suitable metal cage by which the complete retainer could be attached to the flange of the headlamp shell. This type of retainer was held in position by two triangular metal tags which protruded from the cage. The aperture in the headlamp shell incorporating the earlier type of retainer had a raised lip.

Current versions of the F700 MK X headlamp are fitted with a plastics retainer designed to be a press fit into the headlamp shell. Because of this the metal cage is not required. The aperture in the headlamp shell incorporating the new type of retainer does not have a raised lip.

Service stocks of the tag-type retainer are limited. The new type of retainer is therefore to be made available as a replacement for use with both types of lamp.

When fitting the new retainer to the earlier type of lamp proceed as follows:-

1. Carefully lever the two tags away from the lamp shell and press out the old retainer.
2. Whilst holding the lamp shell flange against a suitable support, so that the area near the retainer aperture is supported firmly, carefully flatten the raised lip of the aperture. (Failure to carry out this operation will result in the retainer seating incorrectly.)
3. Insert the retainer in the front of the flange, and mate the contour of the retainer to that of the aperture.
4. Carefully press into position.

The adjustment screw may now be screwed into the retainer.

Part Numbers are as follows:-

<u>Old assembly</u>	Housing	No.	54520550
	Nut	No.	54520551
<u>New retainer</u>		No.	54522798

EARLIER TYPE  
ADJUSTMENT  
SCREW RETAINER

APERTURE WITH  
RAISED LIP FOR  
EARLIER TYPE RETAINER

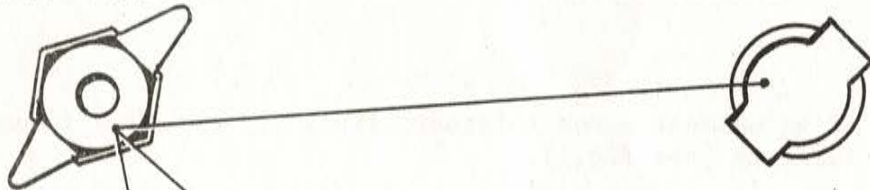

VERTICAL

HORIZONTAL

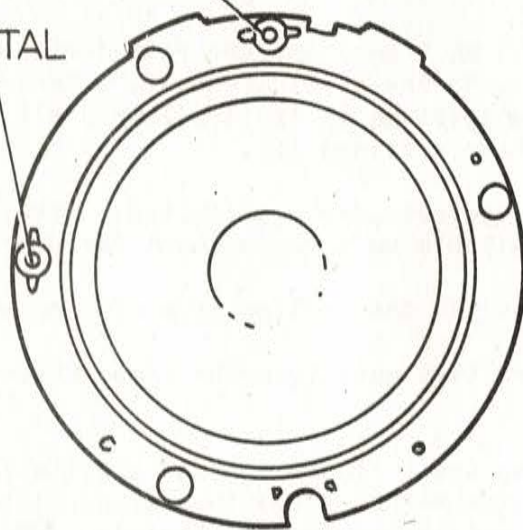

ADJUSTMENT  
SCREW

LATER TYPE  
ADJUSTMENT SCREW  
RETAINER

APERTURE WITHOUT  
RAISED LIP FOR  
LATER TYPE RETAINER



FIG. 1 MODEL F700 MKX HEADLAMP  
ADJUSTMENT SCREW RETAINER