



Service Department:

THE ROVER COMPANY LIMITED

SOLIHULL
WARWICKSHIRE
ENGLAND

**LAND-ROVER SERVICE NEWS LETTER
No. 25**

August 1962

- Item 125** SUBJECT: **INJECTORS**
MODELS: Land-Rover Diesel.
REMARKS: Further to the information given in Land-Rover News Letter No. 20, Item 104, concerning Injectors, please note that Injectors stamped with C.A.V. Despatch number 5345901, Rover Part No. 273452, are suitable for use in Land-Rover 2 litre Diesel models.
- Item 126** SUBJECT: **GENERATOR, 12 VOLT, AC/DC**
MODELS: Land-Rover Series II Petrol.
REMARKS: Should any complaints arise of excessive belt wear, belt slip or inadequate charging rate on Land-Rover Series II models fitted with 12 volt A.C. Generator equipment, that is the type with the generator mounted on the left-hand side of the engine and driven by a belt from the idler pulley, they should be referred to the Rover Company Limited, Technical Service Department, quoting the vehicle and engine number. On receipt of this information guidance and help will then be given to prevent a recurrence of this trouble.
- Item 127** SUBJECT: **GENERATOR, 12 VOLT, AC/DC**
MODELS: Land-Rover Series IIA.
REMARKS: In Land-Rover News Letter No. 23, Item 121, it was stated that service modification kits would not be available for the Land-Rover Series IIA models. This still applies to the Series IIA Diesel models, but for Series IIA Petrol models only we can now offer the Series II type kit, which can be obtained from our Parts Department under Part No. 514304.
Please note that a number of additional parts have been added to Kit Part No. 514304 to enable it to be used on both Series II and Series IIA Petrol models, but there has been no increase in price to cover these items. The Rover Company cannot therefore accept for credit any surplus parts which become available when the kit is fitted.
- Item 128** SUBJECT: **FRONT AXLE**
MODELS: Land-Rover Series IIA.
MODIFICATION: Introduction of Railko bush type of steering damping which gives considerable improvement over the coil spring type used previously.

PART NUMBERS:	Front axle assembly	} 88	1	534173	R.H.D.	
	Front axle assembly		} standard type	1	534176	L.H.D.
	Front axle assembly	} 88 reinforced type,		1	534179	R.H.D.
	Front axle assembly		} optional equipment	1	534180	L.H.D.
	Front axle assembly	} 109		1	534174	R.H.D.
	Front axle assembly		} standard type	1	534177	L.H.D.
	Front axle assembly	} 109 reinforced type,		1	534181	R.H.D.
	Front axle assembly		} optional equipment	1	534182	L.H.D.
	Swivel pin and bracket complete	2	532963
	Swivel bearing housing and bush complete	2	532267	
	Thrust washer for swivel pin	2	528702	

COMMENCING NUMBERS:

Front axles numbered:

- Land-Rover 88 R.H.D. models from 24109241 onwards
- Land-Rover 88 L.H.D. models from 24405089 onwards
- Land-Rover 109 R.H.D. models from 25107786 onwards
- Land-Rover 109 L.H.D. models from 25404200 onwards

REMARKS:

The complete axle assemblies detailed above can be used on any earlier Series II or Series IIA models as applicable. Full information concerning a swivel pin conversion kit to enable the Railko bush type of steering damper to be used on earlier Land-Rover models from 1954 onwards will be found in Land-Rover Service News Letter No. 21, Item 107.

IMPORTANT. The swivel bearing housing and bush complete and the thrust washer for the swivel pin should not be washed in any type of cleaning fluid, otherwise there is a danger that the damping characteristics of the material will be adversely affected,

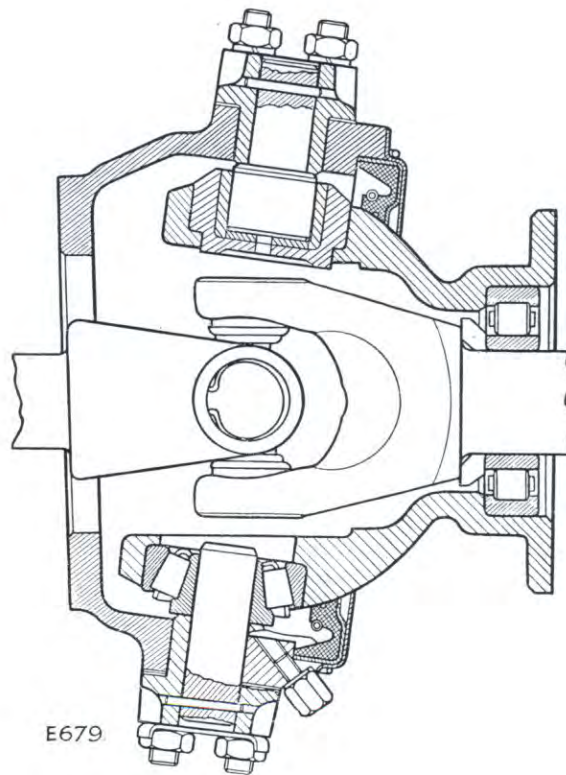

Fig. 1. Cross-section of swivel housing

- Item 129** SUBJECT: **HYDRAULIC STEERING DAMPER ASSEMBLY**
- MODELS: Land-Rover Series II and IIA, 88 and 109 models.
- MODIFICATION: Introduction of a hydraulic steering damper conversion kit for the Land-Rover Series II and IIA, 88 and 109 models, which consists of a hydraulic damper attached at one end to a bracket on the chassis frame and at the other to the steering drag link. This damper may be used in any instance where steering wheel kick is found to be excessive; it does not appreciably increase the steering wheel effort required.
- PART NUMBERS: Hydraulic steering damper assembly 1 536743 R.H.D.
Hydraulic steering damper assembly 1 537283 L.H.D.
- REMARKS: The hydraulic steering damper conversion kit, which is complete with detailed fitting instructions, is now available from our Parts Department.

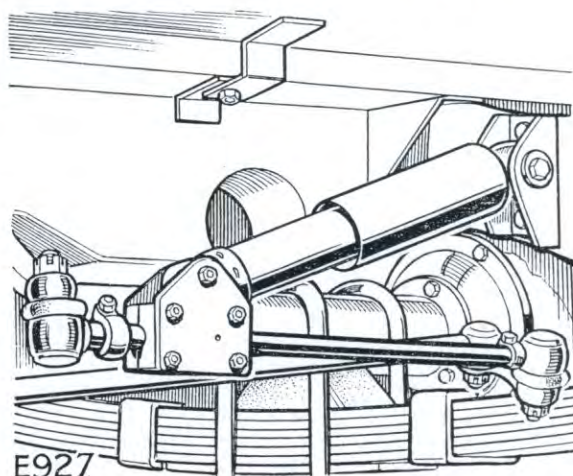

Fig. 2. Hydraulic steering damper shown in position

- Item 130** SUBJECT: **CIBIE 'DIPLOMAT' HEADLIGHT UNIT**
- REMARKS: Cibie 'Diplomat' replacement headlight units are now approved as optional equipment for all Land-Rover models which are fitted with 7 in. (177 mm) headlamps.
- These headlamp units provide instant alternative right-hand dipping for the Continental rule of the road.
- The kit comprises a pair of headlight units which can be, without removing them from their shells, switched over from left-hand to right-hand dipping by simply removing a rubber button in the centre of the headlamp glass and turning a screw head, by means of a coin, anti-clockwise or clockwise as required. Clear or amber bulbs are available.
- When the units are correctly set up for left-hand dip, they are automatically correct for right-hand dipping after switching over.
- The kit, which is complete with detailed fitting instructions, must be ordered direct from: Messrs. Brit-Over Limited, 13, Belsize Lane, London, N.W.3.