



Land Rover Series III

Repair Operation Manual

AKM3648 (EDITION 4)

INTRODUCTION

The purpose of this manual is to assist skilled mechanics in the efficient repair and maintenance of the range of vehicles given on the title-page. The procedures detailed, carried out in the sequence given and using the appropriate service tools, will enable the operations to be completed in the time stated in the Repair Operation Times.

Indexing

The content pages list the titles and reference numbers of the divisions in alphabetical order.

Operation Numbering

Each operation is followed by the number allocated to it in a master index. The number consists of six digits arranged in three pairs.

The master index of operations has been compiled for universal application to vehicles manufactured by British Leyland Motor Corporation and therefore continuity of the numbering sequence is not maintained throughout the manual.

Each instruction within an operation has a sequence number, and to complete the operation in the minimum time it is essential that these instructions are performed in numerical sequence commencing at 1 unless otherwise stated. Where applicable, the sequence numbers identify the components in the appropriate illustration.

Where performance of an operation requires the use of a service tool, the tool number is quoted under the operation heading and is repeated in, or following, the instruction involving its use.

An illustrated list of all service tools necessary to complete the operations described in the manual is also included.

References

References to the left- or right-hand side in the manual are made when viewing the vehicle from the rear. With the engine and gearbox assembly removed, the water pump end of the engine is referred to as the front.

To reduce repetition, operations covered in this manual do not include reference to testing the vehicle after repair. It is essential that work is inspected and tested after completion and if necessary a road test of the vehicle is carried out particularly where safety related items are concerned.

Dimensions

The dimensions quoted are to design engineering specification. Alternative unit equivalents, shown in brackets following the dimensions, have been converted from the original specification.

During the period of running-in from new, certain adjustments may vary from the specification figures given in this Manual. These adjustments will be re-set by the Distributor or Dealer at the After Sales Service, and thereafter should be maintained at the figures specified in the Manual.

REPAIRS AND REPLACEMENTS

When replacement parts are required it is essential that only genuine Land Rover replacements are used.

Attention is particularly drawn to the following points concerning repairs and the fitting of replacement parts and accessories:

Safety features embodied in the vehicle may be impaired if other than genuine Land Rover replacements are fitted. In certain territories, legislation prohibits the fitting of parts not to the vehicle manufacturer's specification. Torque wrench setting figures given in the Repair Operation Manual must be strictly adhered to. Locking devices, where specified, must be fitted. If the efficiency of a locking device is impaired during removal it must be renewed. Owners purchasing accessories while travelling abroad should ensure that the accessory and its fitted location on the vehicle conform to mandatory requirements existing in their country of origin. The terms of the Owners Service Statement may be invalidated by the fitting of other than genuine Land Rover parts.

All genuine Land Rover replacements have the full backing of the Owners Service Statement.

Land Rover Distributors and Dealers are obliged to supply only genuine Land Rover service parts.

POISONOUS SUBSTANCES

WARNING

Many liquids and other substances used in motor vehicles are poisonous and should under no circumstances be consumed and should as far as possible be kept away from open wounds. These substances among others include antifreeze, brake fluid, fuel, windscreen washer additives, lubricants and various adhesives.

FUEL HANDLING PRECAUTIONS

The following information provides basic precautions which must be observed if petrol (gasoline) is to be handled safely. It also outlines the other areas of risk which must not be ignored.

This information is issued for basic guidance only, and in any case of doubt appropriate enquiries should be made of your local Fire Officer.

General

Petrol/gasoline vapour is highly flammable and in confined spaces is also very explosive and toxic.

When petrol/gasoline evaporates it produces 150 times its own volume in vapour, which when diluted with air becomes a readily ignitable mixture. The vapour is heavier than air and will always fall to the lowest level. It can readily be distributed throughout a workshop by air current, consequently, even a small spillage of petrol/gasoline is potentially very dangerous.

Always have a fire extinguisher containing FOAM CO₂ GAS, or POWDER close at hand when handling or draining fuel, or when dismantling fuel systems and in areas where fuel containers are stored.

Always disconnect the vehicle battery BEFORE carrying out dismantling or draining work on a fuel system.

Whenever petrol/gasoline is being handled, drained or stored, or when fuel systems are being dismantled all forms of ignition must be extinguished or removed, any headlamps used must be flameproof and kept clear of spillage.

NO ONE SHOULD BE PERMITTED TO REPAIR COMPONENTS ASSOCIATED WITH PETROL/GASOLINE WITHOUT FIRST HAVING HAD SPECIALIST TRAINING.

Fuel Tank Draining

WARNING: PETROL/GASOLINE MUST NOT BE EXTRACTED OR DRAINED FROM ANY VEHICLE WHILST IT IS STANDING OVER A PIT.

Draining or extracting petrol/gasoline from vehicle fuel tank must be carried out in a well ventilated area.

The receptacle used to contain the petrol/gasoline must be more than adequate for the full amount of fuel to be extracted or drained. The receptacle should be clearly marked with its contents, and placed in a safe storage area which meets the requirements of local authority regulations.

WHEN PETROL/GASOLINE HAS BEEN EXTRACTED OR DRAINED FROM A FUEL TANK THE PRECAUTIONS GOVERNING NAKED LIGHTS AND IGNITION SOURCES SHOULD BE MAINTAINED.

Fuel Tank Removal

On vehicles where the fuel line is secured to the fuel tank outlet by a spring steel clip, it is recommended that such clips are released before the fuel line is disconnected or the fuel tank unit is removed. This procedure will avoid the possibility of residual petrol fumes in the fuel tank being ignited when the clips are released.

As an added precaution fuel tanks should have a PETROL/GASOLINE VAPOUR warning label attached to them as soon as they are removed from the vehicle.

continued

Fuel Tank Repair

Under no circumstances should a repair to any tank involving heat treatment be carried out without first rendering the tank SAFE, by using one of the following methods:

- a STEAMING: With the filler cap and tank unit removed, empty the tank. Steam the tank for at least 2 hours with low pressure steam. Position the tank so that condensation can drain away freely, ensuring that any sediment and sludge not volatilised by the steam, is washed out during the steaming process.
- b BOILING: With the filler cap and tank unit removed, empty the tank. Immerse the tank completely in boiling water containing an effective alkaline degreasing agent or a detergent, with the water filling and also surrounding the tank for at least 2 hours. After steaming or boiling a signed and dated label to this effect should be attached to the tank.

CONTENTS

	<i>Page No.</i>
Preliminary Pages	01
General Specification Data	04
Engine Tuning Data	05
Torque Wrench Settings	06
General Fitting Instructions	07
Recommended Service Lubricants etc.	09
MAINTENANCE	10

ENGINE OPERATIONS – 2¼ litre 4 cylinder Petrol and Diesel

Supplement for five main bearing engine at rear of manual

	<i>Operation No.</i>	<i>Page No.</i>
Camshaft		
–remove and refit	12.13.01	12–3
–bearings—remove and refit	12.13.13	12–3
Connecting rods and pistons		
–remove and refit	12.17.01	12–4
–overhaul	12.17.10	12–5
Crankshaft		
–rear oil seal—remove and refit	12.21.20	12–10
–remove and refit	12.21.33	12–11
–overhaul	12.21.46	12–11
Cylinder		
–head—remove and refit	12.29.10	12–14
–overhaul	12.29.18	12–17
–pressure check—Petrol engine	12.25.01	12–13
–pressure check—Diesel engine	12.25.01	12–23
–side cover, front—remove and refit	12.25.14	12–13
–side cover, rear—remove and refit	12.25.16	12–13
Engine assembly—remove and refit	12.41.01	12–25
Flywheel		
–remove and refit	12.53.07	12–28
–overhaul	12.53.10	12–28
–starter ring gear—remove and refit	12.53.19	12–28
–spigot bearing—remove and refit	12.53.20	12–28
Oil		
–filter assembly, external—remove and refit	12.60.01	12–29
–pump—remove and refit	12.60.26	12–29
–pump—overhaul	12.60.32	12–29
–sump—remove and refit	12.60.44	12–30
Tappets—remove and refit	12.29.57	12–24
Timing		
–gear cover—remove and refit	12.65.01	12–30
–gear cover oil seal—remove and refit	12.65.05	12–30
–gears—remove and refit	12.65.22	12–32
–chain tensioner	12.65.28	12–34
Valve gear		
–remove and refit	12.29.34	12–21
–rocker shaft assembly—overhaul	12.29.55	12–23

ENGINE OPERATIONS – 2.6 litre 6 Cylinder

Camshaft		
–remove and refit	12.13.01	12–36
Connecting rods and pistons		
–remove and refit	12.17.01	12–37
–overhaul	12.17.10	12–38
Crankshaft		
–remove and refit	12.21.33	12–42
–overhaul	12.21.46	12–42

continued

	<i>Operation No.</i>	<i>Page No.</i>
Crankshaft rear oil seal –remove and refit	12.21.20	12–41
Cylinder head –remove and refit	12.29.10	12–44
–top overhaul	12.29.21	12–46
Cylinder pressures –check	12.25.01	12–44
Distributor and oil pump drive shaft –remove and refit	12.10.22	12–36
Engine assembly –remove and refit	12.41.01	12–50
Exhaust valve rockers and shafts –remove and refit	12.29.36	12–48
Flywheel –remove and refit	12.53.07	12–51
–overhaul	12.53.10	12–51
Inlet valve rockers and shafts –remove and refit	12.29.35	12–47
–overhaul (replacing bushes)	12.29.55	12–50
Oil filter, external –remove and refit	12.60.01	12–52
Oil pump –remove and refit	12.60.26	12–52
–overhaul	12.60.32	12–52
Oil strainer –remove and refit	12.60.20	12–52
Oil sump –remove and refit	12.60.44	12–53
Spigot bearing –remove and refit	12.53.20	12–52
Starter ring gear –remove and refit	12.53.19	12–51
Timing chain and gears –remove and refit	12.65.12	12–54
Timing chain tensioner –remove and refit	12.65.28	12–55
Timing gear cover and oil seal –remove and refit cover	12.65.01	12–53
–remove and refit oil seal	12.65.05	12–53

EMISSION CONTROL

Emission Control System Description and Operations

Air injection system		
–Air pump–remove and refit	17.25.07	17–11
–Air pump drive bolt–remove and refit	17.25.15	17–11
–tensioning	17.25.13	17–11
–Air rail/manifold–remove and refit	17.25.19	17–12
–Anti-run-on valve–check	17.40.14	17–12
–remove and refit	17.40.01	17–12
–Check valve–remove and refit	17.25.21	17–12
–test	17.25.22	17–12
–Description of system	17.25.00	17–11
Crankcase breathing system		
–Crankcase emission valve–remove and refit	17.10.09	17–7
–overhaul	17.10.15	17–7
–Description of system	17.10.00	17–6
–Engine breather filter–remove and refit	17.10.02	17–7
–Flame trap–remove and refit	17.10.03	17–7
Evaporative loss control system		
–Adsorption canister–remove and refit	17.15.13	17–8
–Description of system	17.15.00	17–8

continued

	<i>Operation No.</i>	<i>Page No.</i>
Exhaust emission control system		
–Accelerator pump linkage setting	17.20.00	17–8
–Carburetter adjustments	17.20.00	17–8
–Carburetter throttle prop—remove and refit	17.20.35	17–10
–Description of system	17.20.00	17–8
–Fuel filter—remove and refit	17.20.38	17–11
–Ignition system description and ignition timing	17.20.00	17–9
–Throttle controlled vacuum switch—check and adjust	17.20.24	17–10
—remove and refit	17.20.25	17–10
Exhaust Gas Recirculation (E.G.R.) system		
–Description of system	17.45.00	17–12
–E.G.R. valve—overhaul	17.45.02	17–12
—remove and refit	17.45.01	17–12
–system check	17.45.20	17–13
Fault diagnosis		17–2

FUEL SYSTEM

NOTE: Where fuel system equipment has emission control features, refer to Division 17 of this Manual.

Accelerator throttle controls arrangements	19.00.00	19–4
Aircleaner		
–remove and refit	19.10.04	19–7
–clean and refill	19.10.16	19–7
Tamperproof carburetters	19.15.00	19–7
Carburetter		
–remove and refit	19.15.09	19–8
–overhaul and adjust	19.15.17	19–9
Cold start control cable		
–remove and refit	19.20.26	19–16
Diesel fuel system		
–general notes and arrangement	19.00.00	19–2
Engine stop control cable		
–remove and refit	19.20.32	19–17
Fuel distributor/injection pump		
–remove, set timing and refit	19.30.07	19–18
Fuel injectors		
–remove and refit	19.60.01	19–24
–spray check	19.60.02	19–24
–overhaul	19.60.08	19–25
Fuel lift pump		
–remove and refit	19.45.09	19–21
–overhaul	19.45.16	19–21
Fuel filters—Refer to Maintenance Division 10		
Fuel system		
—priming	19.50.01	19–22
Fuel tank		
—remove and refit	19.55.01	19–23
Fuel tank gauge unit—Refer to Division 88 (Controls)		
Thermostat switch		
–remove and refit	19.15.50	19–16
Hand control, engine speed		
–remove and refit	19.20.29	19–17
Throttle linkage		
–remove and refit	19.20.07	19–16

COOLING SYSTEM

Coolant		
–drain and refill	26.10.01	26–1

continued

	<i>Operation No.</i>	<i>Page No.</i>
Expansion tank		
—remove and refit	26.15.01	26—1
Fan blades and pulley		
—remove and refit	26.25.01	26—1
Radiator and front panel assembly—remove and refit	26.40.01	26—2
Radiator		
—remove and refit	26.40.04	26—2
Thermostat		
—remove and refit	26.45.01	26—3
—test	26.45.09	26—3
Water pump		
—remove and refit	25.50.01	26—3
—overhaul	26.50.06	26—4

MANIFOLD AND EXHAUST SYSTEM

Exhaust manifold, 2.6 litre models		
—remove and refit	30.15.10	30—3
Exhaust system		
—front pipe—remove and refit	30.10.09	30—2
—intermediate pipe—remove and refit	30.10.11	30—2
—silencer—remove and refit	30.10.14	30—1
—silencer and tail pipe—remove and refit	30.10.22	30—2
—tail pipe—remove and refit	30.10.19	30—1
Induction and exhaust manifold, 2¼ litre models		
—remove and refit	30.15.01	30—3

CLUTCH

Clutch assembly		
—remove and refit	33.10.01	33—1
—overhaul	33.10.08	33—1
Clutch pedal—remove and refit	33.20.01	33—3
Hydraulic system—bleed	33.15.01	33—1
Master Cylinder		
—remove and refit	33.20.01	33—1
—overhaul	33.20.07	33—2
Release assembly—remove and refit	33.25.12	33—3
Slave cylinder		
—remove and refit	33.35.01	33—4
—overhaul	33.35.07	33—4

GEARBOX

Main gearbox		
Bell housing		
—remove and refit	37.12.07	37—4
—overhaul (includes Primary Pinion remove and refit)	37.12.08	37—4
Clutch release assembly—Refer to Division 33 (Clutch)		
Gearbox assembly		
—remove and refit	37.20.01	37—8
Gearbox main casing		
—remove and refit	37.12.40	37—5
—overhaul	37.12.43	37—5
Gear change lever		
—remove and refit	37.16.04	37—6
—overhaul	37.16.10	37—6
Gear change selectors		
—remove and refit	37.16.31	37—7
—overhaul	37.16.34	37—7

continued

	<i>Operation No.</i>	<i>Page No.</i>
Layshaft		
—remove and refit	37.20.19	37—9
Mainshaft		
—remove and refit	37.20.25	37—10
—overhaul	37.20.31	37—10
Primary pinion		
—remove and refit	refer to 37.12.08	37—4
Reverse idler gear		
—remove and refit	37.20.13	37—9
—overhaul	37.20.14	37—9
Reverse selector stop		
—remove, refit and adjust	37.16.28	37—6
Transfer gearbox		
Intermediate gear assembly		
—remove and refit	refer to 37.29.28	37—14
Speedometer drive housing		
—remove and refit	37.25.09	37—12
—overhaul	37.25.13	37—12
Transfer gearbox complete		
—remove and refit	37.29.25	37—13
—overhaul	37.29.28	37—14
Transmission brake—refer to Division 70 (Brakes)		
Front output housing		
Front output shaft housing		
—remove and refit	37.10.05	37—1
—overhaul	37.10.06	37—1
PROPELLER SHAFT		
Front propeller shaft		
—remove and refit	47.15.02	47—1
—overhaul	47.15.11	47—1
Rear propeller shaft		
—remove and refit	47.15.03	47—1
—overhaul	47.15.12	47—1
REAR AXLE		
Differential assembly (Rover type)—overhaul (early type)	refer to 54.10.07	54—1
Differential assembly (Rover type)—(later type)	refer to 54.10.07	54—4
Differential assembly (88 models)—remove and refit	51.15.01	51—2
Half shaft—remove and refit	51.10.01	51—1
Hub bearings—remove and refit	51.10.28	51—1
Hub oil seal—remove and refit	51.20.17	51—7
Pinion oil seal—remove and refit	51.20.01	51—7
Rear axle assembly—remove and refit	51.25.01	51—8
FRONT AXLE AND FINAL DRIVE		
Axle case oil seal		
—remove and refit	54.15.04	54—8
Front axle assembly		
—remove and refit	54.15.01	54—7
Differential assembly		
—overhaul	54.10.07	54—1
—remove and refit	54.10.01	54—1

continued

	<i>Operation No.</i>	<i>Page No.</i>
Half shaft		
—overhaul	54.20.09	54—9
—remove and refit	54.20.07	54—8
Half shaft and swivel axle		
—remove and refit	54.20.01	54—8
Pinion oil seal		
—remove and refit	54.10.20	54—7

STEERING

Drag link		
—remove and refit	57.55.17	57—9
—ball joints—remove and refit	57.55.16	57—9
Front wheel alignment—check and adjust	57.65.01	57—10
Lock stops—check and adjust	57.65.03	57—11
Longitudinal steering tube		
—remove and refit	57.55.13	57—8
—ball joints—remove and refit	57.55.12	57—8
Steering box—adjust	57.35.01	57—1
Steering column and box assembly		
—remove and refit	57.45.01	57—2
—overhaul	57.45.07	57—4
Steering column lock and ignition/starter switch		
—remove and refit	57.40.31	57—2
Steering column top bearing—remove and refit	57.40.19	57—1
Steering damper—remove and refit	57.35.10	57—1
Steering geometry—check	57.65.02	57—11
Steering levers—Refer to 'Swivel pin' Division 60		
Steering relay		
—remove and refit	57.50.02	57—5
—overhaul	57.50.08	57—6
Steering wheel—remove and refit	57.60.01	57—10
Track rod		
—remove and refit	57.55.09	57—7
—ball joints—remove and refit	57.55.08	57—7

FRONT SUSPENSION

Bump stop—remove and refit	60.30.10	60—6
Front hub		
—bearing end-float—check and adjust	60.25.13	60—5
—bearings—remove and refit	60.25.14	60—5
—hub assembly—remove and refit	60.25.01	60—4
—oil seal—remove and refit	60.25.15	60—5
—stub axle—overhaul	60.25.24	60—5
—stub axle—remove and refit	60.25.22	60—5
—supplementary information		60—7
Front road spring		
—overhaul	60.20.07	60—3
—remove and refit	60.20.01	60—3
—spring hangar bracket bush—remove and refit	60.20.31	60—4
Front shock absorber		
—bushes—remove and refit	60.30.07	60—6
—shock absorber—remove and refit	60.30.02	60—6
Swivel pin housing		
—overhaul	60.15.23	60—1
—remove and refit	60.15.20	60—1

REAR SUSPENSION	<i>Operation No.</i>	<i>Page No.</i>
Bump stop—remove and refit	64.30.10	64-5
Check strap—remove and refit	64.30.17	64-5
Rear drive flange—remove and refit	64.15.04/05	64-1
Rear hub		
—remove and refit	64.15.01	64-1
—hub bearing end-float—check and adjust	64.15.13	64-2
—hub bearings—remove and refit	64.15.14	64-2
—oil seal—remove and refit	64.15.15	64-2
—stub axle—overhaul	64.15.21	64-3
—stub axle—remove and refit	64.15.20	64-3
—supplementary information		60-7
Rear road spring		
—hanger bracket bush—remove and refit	64.20.21	64-4
—overhaul	64.20.04	64-4
—remove and refit	64.20.01	64-3
Shock absorber		
—remove and refit	64.30.05	64-4
 BRAKES		
Brakes		
—adjust	70.25.03	70-6
—bleed	70.25.02	70-5
Brake failure switch		
—remove and refit	70.15.36	70-4
—overhaul	70.15.41	70-4
Brake warning light		
—general	70.10.00	70-1
Drums		
—front—remove and refit	70.10.02	70-2
—rear—remove and refit	70.10.03	70-2
Fluid reservoir		
—remove and refit	70.30.15	70-11
Four way connector		
—remove and refit	70.15.35	70-4
Hoses—remove and refit		
—front L.H.	70.15.02	70-2
—front R.H.	70.15.03	70-2
—intermediate	70.15.04	70-2
Master cylinder—single		
—with servo assistance		
—remove and refit	70.30.01	70-6
—overhaul	70.30.02	70-8
—without servo assistance		
—remove and refit	70.30.01	70-6
—overhaul	70.30.02	70-7
Master cylinder—tandem		
—remove and refit	70.30.08	70-9
—overhaul	70.30.09	70-10
Pedal assembly		
—non-servo systems—remove and refit	70.35.01	70-11
—servo systems—remove and refit	70.35.01	70-12
Pipes—remove and refit		
—failure indicator switch, front	70.20.46	70-3
—to failure indicator switch, rear	70.20.47	70-3
—to intermediate hose	70.20.28	70-2
—to L.H. front cylinder	70.20.04	70-2
—to L.H. front hose	70.20.02	70-2
—to R.H. front cylinder	70.20.05	70-2
—to R.H. front hose	70.20.03	70-2
—to master cylinder	70.20.10	70-2
—to multiway connector	70.20.01	70-2
—to L.H. rear cylinder	70.20.17	70-2
—to L.H. rear hose	70.20.18	70-2

continued

	<i>Operation No.</i>	<i>Page No.</i>
Shoes and linings—remove and refit		
—brake linings	70.40.10	70-14
—brake shoes, front, 88 models	70.40.02	70-13
—brake shoes, front, 109 models	70.40.02	70-13
—brake shoes, rear, 88 models	70.40.03	70-13
—brake shoes, rear, 109 models	70.40.03	70-14
Transmission brake		
—adjust	70.45.09	70-17
—hand lever and linkage—remove and refit	70.45.01	70-14
—remove and refit	70.45.16	70-17
—shoes, remove and refit	70.45.18	70-17
Vacuum system		
—servo assembly—remove and refit	70.50.01	70-18
—servo assembly—overhaul	70.50.06	70-19
—vacuum reservoir tank—remove and refit	70.50.04	70-18
Wheel cylinders		
—front, 88 models		
—remove and refit	70.60.03	70-19
—overhaul	70.60.11	70-19
—front, 109 models		
—remove and refit	70.60.03	70-20
—overhaul	70.60.11	70-20
—rear, 88 models		
—remove and refit	70.60.18	70-19
—overhaul	70.60.26	70-19
—rear, 109 models		
—remove and refit	70.60.18	70-20
—overhaul	70.60.26	70-20
 WHEELS AND TYRES		
General	74.10.00	74-1
 BODY		
Body repairs—general	76.00.00	76-1
Chassis frame—alignment check	76.10.02	76-12
Door lock		
—remove and refit—side-front	76.37.12	76-15
—remove and refit—side-rear	76.37.13	76-15
—remove and refit—tail door	76.37.16	76-15
Fascia support panel—remove and refit	76.46.06	76-17
Fascia top rail—remove and refit	76.46.04	76-16
Front floor—remove and refit	76.10.12	76-13
Front seat base—remove and refit	76.70.06	76-17
Front wing—remove and refit	76.10.26	76-14
Lower fascia—remove and refit	76.46.05	76-16
Side door glass		
—remove and refit—front door	76.31.01	76-15
—remove and refit—rear door	76.31.02	76-15
Windscreen—remove and refit	76.81.02	76-18
Windscreen glass—remove and refit	76.81.03	76-19
 PAINTWORK		
General information	78.00.00	78-1
 HEATER AND VENTILATION		
Air distribution flaps—remove and refit	80.15.09	80-4
Demister hoses—remove and refit	80.15.01	80-3

continued

	<i>Operation No.</i>	<i>Page No.</i>
Demister nozzles—remove and refit	80.15.03	80-3
Fresh air intake—remove and refit	80.15.29	80-4
Heater		
/blower fan motor—remove and refit	80.20.15	80-5
—box complete—remove and refit	80.20.01	80-4
—controls—remove and refit	80.10.02	80-1
—fan switch—remove and refit	80.10.22	80-2
/ventilator air flow		
—control cable—remove and refit	80.10.06	80-1
—water valve—remove and refit	80.10.16	80-2
—water valve control cable—remove and refit	80.10.07	80-2
Pipes		
—feed to heater—remove and refit	80.25.15	80-5
—return from heater—remove and refit	80.25.16	80-5
Ventilator grille panel—remove and refit	80.15.16	80-4

WIPERS AND WASHERS

Headlamp wipers and washers		
—general	84.20.00	84-5
Windscreen washer		
—jets—remove and refit	84.10.09	84-1
—pump—remove and refit	84.10.21	84-2
—reservoir—remove and refit	84.10.01	84-1
—tubes—remove and refit	84.10.15	84-1
Windscreen wiper		
—arms—remove and refit	84.15.01	84-2
—motor and drive—remove and refit	84.15.09	84-2
—motor, drive and wheel boxes—remove and refit	84.15.10	84-3
—motor—overhaul	84.15.18	84-4

ELECTRICAL OPERATIONS

Alternator		
—data	86.10.00	86-11
—description		86-10
—functional check	86.10.01	86-11
—remove and refit	86.10.02	86-13
—overhaul	86.10.08	86-14
Battery—remove and refit	86.15.01	86-16
Circuit diagrams		86-6
Contract breaker points—remove and refit	86.35.13	86-18
Contact gap—adjust	86.35.14	86-18
Distributor		
—remove and refit	86.35.20	86-20
—overhaul	86.35.26	86-21
Electrical equipment—general	86.00.00	86-1
Flasher unit—remove and refit	86.55.11	86-24
Fuse box—remove and refit	86.70.01	86-33
Heater plugs—remove, clean and refit	86.35.08	86-17
Horn—remove and refit	86.30.09	86-17
Ignition coil—remove and refit	86.35.32	86-23
Ignition timing—adjust	86.35.15	86-19
Inspection socket—remove and refit	86.45.33	86-24
Lamps		
—remove and refit		
—front flasher	86.40.42	86-23
—front side	86.40.34	86-23
—headlamp assembly	86.40.02	86-23

continued

	<i>Operation No.</i>	<i>Page No.</i>
-panel illumination	86.45.31	86—24
-rear flasher	86.40.45	86—23
-tail and stop	86.40.79	86—23
-warning lights	86.45.31	86—24
Starter motor		
-remove and refit	86.60.01	86—25
-overhaul	86.60.13	86—25
-solenoid—remove and refit	86.60.08	86—25
Switches		
-remove and refit		
-choke warning light	86.65.53	86—32
-combined, direction indicator/headlight/horn	86.65.55	86—33
-ignition/starter—heater/starter	86.65.02	86—30
-lighting	86.65.10	86—31
-panel light	86.65.12	86—31
-stop light	86.65.51	86—32
-windscreen wiper/washer	86.65.38	86—31

INSTRUMENTS

Coolant temperature gauge		
-remove and refit	88.25.14	88—3
Coolant temperature transmitter		
-remove and refit	88.25.20	88—3
Fuel gauge		
-remove and refit	88.25.26	88—4
Fuel tank gauge unit		
-remove and refit	88.25.32	88—4
Instrument panel		
-remove and refit	88.20.01	88—1
Oil pressure warning switch		
-remove and refit	88.25.08	88—2
Speedometer		
-remove and refit	88.30.01	88—5
Speedometer cable complete		
-remove and refit	88.30.06	88—5
Speedometer cable, inner		
-remove and refit	88.30.07	88—5
Voltage stabilizer		
-remove and refit	88.20.26	88—2

SERVICE TOOLS 99

ABBREVIATIONS AND SYMBOLS

Across flats (bolt size)	A.F.	Negative (electrical)	—
After bottom dead centre	A.B.D.C.	Newton metre	Nm
After top dead centre	A.T.D.C.	Number	No.
Alternating current	a.c.	Ounces (force)	ozf
Amperes	A	Ounces (mass)	oz
Ampere-hour	Ah	Ounce inch (torque)	ozf in
Atmospheres	Atm	Outside diameter	o.dia
		Overdrive	O/D
Before bottom dead centre	B.B.D.C.	Paragraphs	para.
Before top dead centre	B.T.D.C.	Part Number	Part No.
Bottom dead centre	B.D.C.	Percentage	%
Brake horse power	b.h.p.	Pints (Imperial)	pt
Brake mean effective pressure	b.m.e.p.	Pints (U.S.)	U.S. pt
British Standards	B.S.	Plus or minus	±
		Plus (tolerance)	+
Carbon monoxide	CO	Positive (electrical)	+
Centigrade (Celsius)	C	Pounds (force)	lbf
Centimetres	cm	Pounds (mass)	lb
Cubic centimetres	cm ³	Pounds feet (torque)	lbf ft
Cubic inches	in ³	Pounds inches (torque)	lbf in
Cycles per minute	c/min	Pounds per square inch	lbf/in ²
		Radius	r
Degree (angle)	deg. or °	Ratio	:
Degree (temperature)	deg. or °	Reference	ref.
Diameter	dia.	Revolutions per minute	rev/min
Direct current	d.c.	Right-hand	R.H.
		Right-hand steering	R.H.Stg.
Fahrenheit	F		
Feet	ft	Second (angle)	"
Feet per minute	ft/min	Second (numerical order)	2nd
Fifth	5th	Single carburetter	SC
Figure (illustration)	Fig.	Society of Automobile Engineers	S.A.E.
First	1st	Specific gravity	sp. gr.
Fourth	4th	Square centimetres	cm ²
		Square inches	in ²
Gallons (Imperial)	gal	Standard	std.
Gallons (U.S.)	U.S. gal	Standard wire gauge	s.w.g.
Grammes (force)	gf	Synchronizer/synchromesh	synchro.
Grammes (mass)	g		
High compression	h.c.	Third	3rd
High tension (electrical)	h.t.	Top dead centre	T.D.C.
Horse-power	hp	Twin carburetters	TC
Hundredweight	cwt		
		United Kingdom	UK
Inches	in	Volts	V
Inches of mercury	inHg	Watts	W
Independent front suspension	i.f.s.		
Internal diameter	i.dia.	Screw threads	
		American Standard Taper Pipe	N.P.T.F.
Kilogrammes (force)	kgf	British Association	B.A.
Kilogrammes (mass)	kg	British Standard Fine	B.S.F.
Kilogramme centimetre	kgf cm	British Standard Pipe	B.S.P.
Kilogramme metres	kgf m	British Standard Whitworth	B.S.W.
Kilogrammes per square centimetre	kgf/cm ²	Unified Coarse	U.N.C.
Kilometres	km	Unified Fine	U.N.F.
Kilometres per hour	km/h		
Kilovolts	kV		
King pin inclination	k.p.i.		
Left-hand	L.H.		
Left-hand steering	L.H.Stg.		
Left-hand thread	L.H.Thd.		
Low compression	l.c.		
Low tension	l.t.		
Maximum	max.		
Metres	m		
Miniature Edison Screw	MES		
Miles per gallon	m.p.g.		
Miles per hour	m.p.h.		
Millimetres	mm		
Millimetres	mm		
Millimetres of mercury	mmHg		
Minimum	min.		
Minus (of tolerance)	—		
Minute (of angle)	'		

GENERAL SPECIFICATION DATA

ENGINE — 2½ LITRE PETROL

Type	4 cylinder
Bore	90,47 mm (3.562 in.)
Stroke	88,9 mm (3.500 in.)
Capacity	2286 cm ³ (139.500 in. ³)
Valve operation	Overhead by pushrod
Crankshaft	
Main journal diameter	63,487 mm to 63,500 mm (2.4995 in. to 2.500 in.)
Minimum regrind diameter	62,48 mm (2.460 in.)
Crankpin journal diameter	58,72 mm to 58,733 mm (2.312 in. to 2.31275 in.)
Minimum regrind diameter	57,70 mm (2.272 in.)
Crankshaft end thrust	Taken on thrust washers at centre main bearing
Crankshaft end float	0,05 mm to 0,15 mm (0.002 in. to 0.006 in.)
Main bearings	
Number and type	3 halved shells
Material	Steel shell, tin-aluminium lined
Diametrical clearance	0,020 mm to 0,072 mm (0.0008 in. to 0.00285 in.)
Undersizes	0,25 mm, 0,50 mm, 0,76 mm, 1,01 mm (0.010 in., 0.020 in., 0.030 in., 0.040 in.)
Connecting rods	
Type	Horizontally split big end, plain small end
Length between centres	175,36 mm to 175,46 mm (6.904 in. to 6.908 in.)
Big end bearings	
Type and material	Steel shell, copper-lead lined
Diametrical clearance	0,019 mm to 0,068 mm (0.00075 in. to 0.0027 in.)
End float on crankpin	0,02 mm to 0,03 mm (0.007 in. to 0.012 in.)
Undersizes	0,25 mm, 0,50 mm, 0,76 mm, 0,01 mm (0.010 in., 0.020 in., 0.030 in., 0.040 in.)
Gudgeon pins	
Type	Floating
Fit in piston	Push fit by hand
Clearance in connecting rod	0,007 mm to 0,015 mm (0.0003 in. to 0.0006 in.)
Pistons	
Type	Aluminium alloy, flat top
Clearance in bore, measured at bottom of skirt at right angles to gudgeon pin	
Standard size pistons	0,0479 mm to 0,0612 mm (0.0019 in. to 0.0024 in.)
Oversize pistons	0,043 mm to 0,055 mm (0.0017 in. to 0.0022 in.)

Piston rings	
Compression	2
Gap in bore	0,38 mm to 0,50 mm (0.015 in. to 0.020 in.)
Clearance in groove	0,046 mm to 0,097 mm (0.0018 in. to 0.0038 in.)
Oil control	
Oil control	1
Gap in bore	0,38 mm to 0,50 mm (0.015 in. to 0.020 in.)
Clearance in groove	0,038 mm to 0,089 mm (0.0015 in. to 0.0035 in.)
Camshaft	
Location	Right-hand side (thrust side) of engine
End float	0,06 mm to 0,13 mm (0.0025 in. to 0.0055 in.)
Number of bearings	4
Material	Steel shell, white metal lined
Valves	
Length	
Inlet	111,25 mm to 111,60 mm (4.380 in. to 4.394 in.)
Exhaust	111,22 mm to 111,58 mm (4.379 in. to 4.393 in.)
Seat angle	
Inlet	30°
Exhaust	45°
Head diameter	
Inlet	44,45 mm to 44,57 mm (1.750 in. to 1.755 in.)
Exhaust	35,02 mm to 35,05 mm (1.375 in. to 1.380 in.)
Stem diameter	
Inlet	7,891 mm to 7,904 mm (0.3107 in. to 0.3112 in.)
Exhaust	8,661 mm to 8,674 mm (0.3410 in. to 0.3415 in.)
Stem to guide clearance	
Inlet	0,033 mm to 0,048 mm (0.0013 in. to 0.0019 in.)
Exhaust	0,058 mm to 0,073 mm (0.0023 in. to 0.0029 in.)
Valve lift	
Inlet	10,236 mm (0.403 in.)
Exhaust	9,85 mm (0.388 in.)

continued

Valve springs

Type	Duplex interference coil
Inner	
Length, free	42,67 mm (1.680 in.)
Length, under 8,0 kg (17.7 lb) load ..	37,13 mm (1.462 in.)
Outer	
Length, free	46,28 mm (1.822 in.)
Length, under 21 kg (46 lb.) load ...	40,30 mm (1.587 in.)

Valve timing

Inlet opens	6° B.T.D.C.
Inlet closes	52° A.B.D.C.
Inlet peak	113° A.T.D.C.
Exhaust opens	34° B.B.D.C.
Exhaust closes	24° A.T.D.C.
Exhaust peak	95° B.T.D.C.

Lubrication

System	Wet sump, pressure fed
System pressure, engine warm at 2000 rev/min	2,45 to 4,5 kgf/cm ² (35 to 65 lbf/in. ²)
Oil pump	
Type	Double gear
Drive	Splined shaft from camshaft skew gear
End float of gears	
Steel gear	0,05 mm to 0,12 mm (0.002 in. to 0.005 in.)
Aluminium gear	0,07 mm to 0,15 mm (0.003 in. to 0.006 in.)
Radial clearance of gears	0,02 mm to 0,10 mm (0.001 in. to 0.004 in.)
Backlash of gears	0,15 mm to 0,28 mm (0.006 in. to 0.012 in.)

Oil pressure relief valve

Type	Non-adjustable
Relief valve spring	
Full length	67,82 mm (2.670 in.)
Compressed length at 2,58 kg (5.7 lb.) load	61,23 mm (2.450 in.)

ENGINE – 2¼ LITRE DIESEL

Type	4-cylinder
Bore	90,47 mm (3.562 in.)
Stroke	88,9 mm (3.500 in.)
Capacity	2286 cm ³ (139 in. ³)
Valve operation	Overhead by push rod

Crankshaft

Main bearing journal diameter	63,487 mm to 63,500 mm (2.4995 in. to 2.5000 in.). Regrinding NOT permitted.
Crankpin journal diameter	58,72 mm to 58,733 mm (2.312 in. to 2.31275 in.). Regrinding NOT permitted.
Crankshaft end thrust	Taken on thrust washers at centre main bearing
Crankshaft end float	0,05 mm to 0,15 mm (0.002 in. to 0.006 in.)

Main bearings

Number and type	3 halved shells
Material	Steel shell, copper-lead lined, tin plated
Diametrical clearance	0,020 mm to 0,063 mm (0.0008 in. to 0.0025 in.)

Connecting rods

Type	Horizontally split big end, plain small end
Length between centres	175,38 mm to 175,43 mm (6.905 in. to 6.907 in.)

Big end bearings

Type and material	Steel shell, copper-lead lined
Diametrical clearance	0,019 mm to 0,068 mm (0.00075 in. to 0.0027 in.)
End float on crankpin	0,20 mm to 0,30 mm (0.007 in. to 0.012 in.)

Gudgeon pins

Type	Floating
Fit in piston	Push fit by hand
Clearance in connecting rod	0,0076 mm to 0,0178 mm (0.0003 in. to 0.0007 in.)

Pistons

Type	Aluminium alloy, with V shape recess in crown
Clearance in bore, measured at bottom of skirt at right angles to gudgeon pin	
Standard size pistons	0,111 mm to 0,134 mm (0.0044 in. to 0.0053 in.)
Oversize pistons	0,111 mm to 0,157 mm (0.0044 in. to 0.0062 in.)

Piston rings**Compression No. 1 (top)**

Type	Square friction edge, chrome plated
Gap in bore	0,35 mm to 0,50 mm (0.014 in. to 0.019 in.)
Clearance in groove	0,06 mm to 0,11 mm (0.0025 in. to 0.0045 in.)

Compression Nos. 2 and 3

Type	Bevelled friction edge. Marked 'T' or 'TOP' on upper side
Gap in bore	0,25 mm to 0,38 mm (0.010 in. to 0.015 in.)
Clearance in groove	0,06 mm to 0,11 mm (0.0025 in. to 0.0045 in.)

Oil control No. 4

Type	Expander and rails
Gap in bore	0,38 mm to 1,14 mm (0.015 in. to 0.045 in.)
Clearance in groove	0,038 mm to 0,064 mm (0.0015 in. to 0.0025 in.)

Camshaft

Location	Right-hand side (thrust side) of engine
End float	0,06 mm to 0,13 mm (0.0025 in. to 0.0055 in.)
Number of bearings	4
Material	Steel shell, white metal lined

Valves

Length	
Inlet	116,38 mm to 116,58 mm (4.582 in. to 4.590 in.)
Exhaust	116,89 mm to 117,09 mm (4.602 in. to 4.610 in.)
Seat angle	
Inlet	45°
Exhaust	45°
Head diameter	
Inlet	39,16 mm to 39,26 mm (1.542 in. to 1.546 in.)
Exhaust	33,32 mm to 33,42 mm (1.312 in. to 1.316 in.)
Stem diameter	
Inlet	7,891 mm to 7,904 mm (0.3107 in. to 0.3112 in.)
Exhaust	8,661 mm to 8,674 mm (0.3410 in. to 0.3415 in.)
Stem to guide clearance	
Inlet	0,033 mm to 0,048 mm (0.0013 in. to 0.0019 in.)
Exhaust	0,058 mm to 0,073 mm (0.0023 in. to 0.0029 in.)
Valve lift	
Inlet	9,85 mm (0.388 in.)
Exhaust	10,26 mm (0.404 in.)

Valve springs

Type	Duplex Interference coil
Inner	
Length, free	42,67 mm (1.680 in.)
Length, under 8,0 kg (17.7 lb.) load ..	40,30 mm (1.587 in.)
Outer	
Length, free	46,28 mm (1.822 in.)
Length, under 21 kg (46 lb.) load ..	40,30 mm (1.587 in.)

Valve timing

Inlet opens	16° BTDC
Inlet closes	42° ABDC
Inlet peak	103° ATDC
Exhaust opens	51° BBDC
Exhaust closes	13° ATDC
Exhaust peak	109° BTDC

Lubrication

System	Wet sump, pressure fed
System pressure, engine warm at 2000 rev/min	2,5 to 4,57 kgf/cm ² (35 to 65 lbf/in. ²)
Oil pump	
Type	Double gear
Drive	Splined shaft from camshaft skew gear
End float of gears	
Steel gear	0,05 mm to 0,12 mm (0.002 in. to 0.005 in.)
Aluminium gear	0,07 mm to 0,15 mm (0.003 in. to 0.006 in.)
Radial clearance of gears	0,02 mm to 0,10 mm (0.001 in. to 0.004 in.)
Backlash of gears	0,15 mm to 0,28 mm (0.006 in. to 0.012 in.)

Oil pressure relief valve

Type	Non-adjustable
Relief valve spring	
Free length	67,82 mm (2,670 in.)
Compressed length at 2.58 kg (5.7 lb.) load	61,23 mm (2.450 in.)

ENGINE – 2.6 LITRE PETROL

Type	6-cylinder
Bore	77,8 mm (3.063 in.)
Stroke	92,075 mm (3.625 in.)
Capacity	2625 cm ³ (160.3 in. ³)
Valve operation	Inlet – overhead by push rod Exhaust – side by cam follower
Crankshaft	
Main journal diameter	66,64 mm to 66,66 mm (2.624 in. to 2.6245 in.)
Minimum regrind diameter	65,63 mm (2.584 in.)
Crankpin journal diameter	47,62 mm to 47,64 mm (1.875 in. to 1.87575 in.)
Minimum regrind diameter	46,60 (1.835 in.)
Crankshaft end thrust	Taken on thrust washers at rear main bearing
Crankshaft end float	0,05 mm to 0,15 mm (0.002 in. to 0.006 in.)
Main bearings	
Number and type	7 halved shells
Material	Steel shell, copper-lead lined, tin plated
Diametrical clearance	0,015 mm to 0,050 mm (0.0006 in. to 0.002 in.)
Undersizes	0,25 mm, 0,50 mm, 0,76 mm, 1,01 mm (0.010 in., 0.020 in., 0.030 in., 0.040 in.)
Connecting rods	
Type	Horizontally split big end, plain small end
Length between centres	206,463 mm (8.1285 in.)
Big end bearings	
Type and material	Steel shell, copper-lead, tin plated
Diametrical clearance	0,019 mm to 0,063 mm (0.00075 in. to 0.0025 in.)
End float on crankpin	0,15 mm to 0,38 mm (0.006 in. to 0.015 in.)
Undersizes	0,25 mm, 0,50 mm, 0,76 mm, 1,01 mm (0.010 in., 0.020 in., 0.030 in., 0.040 in.)
Gudgeon pins	
Type	Fully floating
Fit in piston	Push fit by hand
Clearance in connecting rod	Zero to 0,0241 mm (0.00095 in.)
Pistons	
Type	Aluminium alloy, ridged top
Clearance in bore, measured at bottom of skirt at right angles to gudgeon pin.	
Standard size and oversize pistons	0,048 mm to 0,060 mm (0.0019 in. to 0.0024 in.)

Piston rings

Compression	2
Gap in bore	0,38 mm to 0,50 mm (0.015 in. to 0.020 in.)
Clearance in groove	0,046 mm to 0,097 mm (0.0018 in. to 0.0038 in.)
Oil control	1
Gap in bore	0,38 mm to 0,80 mm (0.015 in. to 0.033 in.)
Clearance in groove	0,05 mm to 0,10 mm (0.002 in. to 0.004 in.)

Camshaft

Location	Left-hand side of engine
End float	0,11 mm to 0,16 mm (0.0045 in. to 0.0065 in.)
Number of bearings	1
Material	Split 'Mazak' castings

Valves

Length	
Inlet	96,57 mm to 96,77 mm (3.802 in. to 3.810 in.)
Exhaust	116,07 mm to 116,28 mm (4.570 in. to 4.578 in.)
Seat angle	
Inlet	30°
Exhaust	45°
Head diameter	
Inlet	45,54 mm to 45,64 mm (1.793 in. to 1.797 in.)
Exhaust	32,02 mm to 32,13 mm (1.261 in. to 1,265 in.)
Stem diameter	
Inlet	8,68 mm to 8,69 mm (0.342 in. to 0.3425 in.)
Exhaust	8,66 mm to 8,67 mm (0.341 in. to 0.3415 in.)
Stem to guide clearance	
Inlet	0,033 mm to 0,048 mm (0.0013 in. to 0.0019 in.)
Exhaust	0,058 mm to 0,073 mm (0.0023 in. to 0.0029 in.)
Valve lift	
Inlet	9,49 mm (0.374 in.)
Exhaust	10,23 mm (0.403 in.)

continued

Valve springs	
Type	Duplex. Interference coil
Inlet	
Inner	
Length, free	43,26 mm (1.703 in.)
Length under 9,7 kg (21.5 lb.) load ..	36,49 mm (1.437 in.)
Outer	
Length, free	49,80 mm (1.960 in.)
Length under 31,5 kg (69.5 lb.) load.	41,27 mm (1.625 in.)
Exhaust	
Inner	
Length, free	43,26 mm (1.703 in.)
Length under 9,1 kg (16.4 lb.) load :	38,10 mm (1.500 in.)
Outer	
Length, free	47,26 mm (1.861 in.)
Length under 18,9 kg (41.8 lb.) load.	41,27 mm (1.625 in.)
Valve timing	
Inlet opens	12° BTDC
Inlet closes	46° ABDC
Inlet peak	107° ATDC
Exhaust opens	47° BBDC
Exhaust closes	17° ATDC
Exhaust peak	75° ABDC
Lubrication	
System	Wet sump, pressure fed
System pressure, engine warm at 2000 rev/min	2,81 to 3,51 kgf/cm ² (40 to 50 lbf/in. ²)
Oil pump	
Type	Spur gear
Drive	Splined shaft from camshaft skew gear
End float of gears	
Steel gear	0,05 mm to 0,12 mm (0.002 in. to 0.005 in.)
Aluminium gear	0,07 mm to 0,15 mm (0.003 in. to 0.006 in.)
Radial clearance of gears	0,02 mm to 0,102 mm (0.001 in. to 0.004 in.)
Backlash of gears	0,20 mm to 0,28 mm (0.008 in. to 0.012 in.)
Oil pressure relief valve	
Type	non-adjustable
Relief valve spring	
Free length	87,0 mm (3.425 in.)
Compressed length at 7,9 kg (17.5 lb.) load	50,55 (1.990 in.)

CLUTCH	
Make	Borg and Beck
Type	Diaphragm spring
Drive plate diameter	241 mm (9.500 in.)
Damper spring colour	Dark green (Petrol) Dark grey/Light green (Diesel)
Facing material	FERODO RYZ

TRANSMISSION	
Main gearbox	
Type	Single helical constant mesh with synchro-mesh on all forward speeds

Ratios:	
Top	Direct
Third	1.50:1
Second	2.22:1
First	3.68:1
Reverse: Suffix 'A' gearbox	3.887:1
Suffix 'B' gearbox	4.021:1

Transfer gearbox	
Type	Two speed reduction on main gearbox output
Front wheel drive	Two/four wheel drive control on transfer, box output

Ratios:		
Helical and spur gear transfer gearbox ..	High transfer	Low transfer
All helical transfer gearbox	1.15:1	2.35:1
Overall ratios (final drive) with helical and spur gear transfer gearbox.	1.53:1	3.27:1
Top	5.4:1	11.1:1
Third	8.05:1	16.5:1
Second	12.0:1	24.6:1
First	19.88:1	40.7:1
Reverse: Suffix 'A' gearbox	20.47:1	42.87:1
Suffix 'B' gearbox	21.6:1	44.31:1
Overall ratios (final drive) with all helical transfer gearbox.		
Top	7.19:1	15.4:1
Third	10.81:1	23.1:1
Second	15.96:1	34.1:1
First	26.46:1	56.56:1
Reverse: Suffix 'A' gearbox	27.87:1	59.76:1
Suffix 'B' gearbox	28.91:1	61.78:1

REAR AXLE	
Type	Spiral bevel
Ratio	4.7:1
	109 in W/B 4.7:1 Hypoid
	fully floating

continued

FRONT AXLE

Differential	Spiral bevel
Front wheel drive	Enclosed universal joints
Ratio	4.7:1

PROPELLER SHAFTS

Type	Hardy-Spicer, needle bearing
Diameter of tubular shaft	50,8 mm (2.000 in.)
Overall length (face to face in midway position)	
Front shaft – 4-cylinder models ..	604,8 mm (23.812 in.)
Front shaft – 6-cylinder models ..	693,7 mm (27.312 in.)
Rear shaft – 88 models	554,00 mm (21.812 in.)
Rear shaft – 109 4-cylinder models .	1042,9 mm (41.062 in.)
Rear shaft – 109 6-cylinder models .	955,7 mm (37.625 in.)

COOLING SYSTEM

Type	Pressurized spill return system with thermostat control, pump and fan assisted
Thermostat	72°C (162°F)
Pressure cap	0,6 kgf cm ² (9 lbf in. ²)
Type of pump	Centrifugal

FUEL SYSTEM

Carburetter	see 'ENGINE TUNING DATA'
Air Cleaner	Oil bath with built in centrifugal pre-cleaner
Fuel pump	
2¼ litre 4-cylinder Petrol	
Type	Mechanical
Pressure range	0,10 to 0,17 kgf cm ² (1.5 to 2.5 lbf in. ²)
2¼ litre 4-cylinder Diesel	
Type	Mechanical
Pressure range	0,35 to 0,56 kgf cm ² (5 to 8 lbf in. ²)
2.6 litre 6-cylinder Petrol	
Type	Electrical – Dual inlet
Pressure range	0,15 to 0,26 kgf cm ² (2.25 to 3.75 lbf in. ²)
Injection system 2¼ litre Diesel	
Injection pump	CAV mechanically-governed distributor type
Injectors	CAV Pintaux
Nozzle size	BDNO/SPC 6209
Operating pressure of nozzle valve ..	135 atm
Back leakage rate 150 to 100 atm ..	
New nozzle	7 seconds
Original nozzle	5 seconds
Start of injection	13° BTDC

SUSPENSION

Type..... Springs	Rigid axles, semi-elliptic springs					
	88-Petrol	88-Diesel	109-Petrol	109-Diesel	Heavy Duty	Extra Heavy Duty
Front (Driver)						
Length.....	36.25 in.	36.25 in.	36.25 in.	36.25 in.	36.25 in.	36.25 in.
Width.....	2.5 in.	2.5 in.	2.5 in.	2.5 in.	2.5 in.	2.5 in.
No. of leaves.....	9	11	11	11	11	11
Thickness						
1 at.....	0.203 in.	0.203 in.	0.203 in.	0.203 in.	0.203 in.	0.203 in.
8 at.....	0.165 in.					
10 at.....		0.172 in.	0.172 in.	0.172 in.	0.172 in.	0.172 in.
Rate.....	203 lb. in.	273 lb. in.	273 lb. in.	273 lb. in.	273 lb. in.	273 lb. in.
Free camber.....	6.080 in.	5.625 in.	5.625 in.	6.125 in.	6.125 in.	6.25 in.
Front (Passenger)						
Length.....	36.25 in.	36.25 in.	36.25 in.	36.25 in.,	36.25 in.	36.25 in.
Width.....	2.5 in.	2.5 in.	2.5 in.	2.5 in.	2.2 in.	2.5 in.
No. of leaves.....	9	11	11	11	11	11
Thickness						
1 at.....	0.203 in.	0.203 in.	0.203 in.	0.203 in.	0.203 in.	0.203 in.
8 at.....	0.165 in.					
10 at.....		0.172 in.	0.172 in.	0.172 in.	0.172 in.	0.172 in.
Rate.....	203 lb. in.	273 lb. in.	273 lb. in.	273 lb. in.	273 lb. in.	273 lb. in.
Free camber.....	5.330 in.	5.125 in.	5.125 in.	5.625 in.	5.625 in.	5.625 in.
Rear (Driver)						
Length.....	48 in.	48 in.	48 in.	48 in.	48 in.	48 in.
Width.....	2.5 in.	2.5 in.	2.5 in.	2.5 in.	2.5 in.	2.5 in.
No. of leaves.....	11	11	10	10	8	9
Thickness						
1 at.....	0.250 in.	0.250 in.	0.250 in.	0.250 in.		
2 at.....			0.375 in.	0.375 in.		
7 at.....			0.156 in.	0.156 in.		
8 at.....					0.281 in.	
9 at.....						0.281 in.
10 at.....	0.187 in.	0.187 in.				
Rate.....	166 lb. in.	166 lb. in.	270 lb. in.	270 lb. in.	368 lb. in.	415 lb. in.
Free camber.....	7.420 in.	7.420 in.	9.250 in.	9.250 in.	5.187 in.	6.187 in.
Rear (Passenger)						
Length.....	48 in.	48 in.	48 in.	48 in.	48 in.	48 in.
Width.....	2.5 in.	2.5 in.	2.5 in.	2.5 in.	2.5 in.	2.5 in.
No. of leaves.....	11	11	10	10	8	9
Thickness						
1 at.....	0.250 in.	0.250 in.	0.250 in.	0.250 in.		
2 at.....			0.375 in.	0.375 in.		
7 at.....			0.156 in.	0.156 in.		
8 at.....					0.281 in.	
9 at.....						0.281 in.
10 at.....	0.187 in.	0.187 in.				
Rate.....	166 lb. in.	166 lb. in.	270 lb. in.	270 lb. in.	368 lb. in.	415 lb. in.
Free camber.....	6.750 in.	6.750 in.	8.200 in.	8.200 in.	4.750 in.	6.187 in.

Hydraulic dampers	Telescopic: non-adjustable
Piston diameter	
88 models	25,4 mm (1.000 in.)
109 models	34,6 mm (1.375 in.)
STEERING	
Type	Recirculating ball
Ratio: Straight ahead	15.6:1
Full lock	23.8:1
Low ratio (109 one-ton model):	
Straight ahead	19.6:1
Full lock	29.9:1
Front wheel toe-in	1,2 mm to 2,4 mm (0.046 in. to 0.093 in.)
Camber angle	1½°
Castor angle	3°
Swivel pin inclination	7°

BRAKES

System	Single line, non servo	} According to requirements
	Single line with servo	
	Dual line	

Front

Drum diameter	
88 models	254 mm (10 in.)
109 models	279,4 mm (11 in.)
Reclamation limit	0,75 mm (0.030 in.) oversize
Wheel cylinder bore diameter	
88 models	31,75 mm (1.250 in.) Single leading shoe
109 models	27,57 mm (1.125 in.) Twin leading shoe
Lining dimensions	
88 models	220,98 mm × 38,1 mm × 4,75 mm (8.700 in. × 1.500 in. × 0.187 in.)
109 models	
2710 Gross Vehicle weight	264,66 mm × 57,15 mm × 4,74 mm (10.42 in. × 2.25 in. × 0.187 in.)
3020 Gross Vehicle weight	279,4 mm × 76,2 mm × 4,74 mm (11.0 in. × 3.0 in. × 0.187 in.)
Lining material	Don 269 All Models from June 77

Rear

Drum diameter	
88 models	254 mm (10 in.)
109 models	279,4 mm (11 in.)
Reclamation limit	See page 70-2
Wheel cylinder bore diameter	31,75 mm (1.250 in.) single shoe
Lining dimensions	
88 models	220,98 mm × 38,1 mm × 4,74 mm (8.700 in. × 1.500 in. × 0.18 in.)
109 models	264,66 mm × 57,15 mm × 4,74 mm (10.42 in. × 2.25 in. × 0.18 in.)
Lining material	Don 269 All Models from June 77

Hand brake

Drum diameter	228,6 mm (9.000 ins.)
Lining dimensions	209,55 mm × 44,45 mm × 4,74 mm (8.250 in. × 1.750 in. × 0.187 in.)
Master cylinder bore diameter	
88 models, non servo	19,00 mm (0.750 in.)
88 models, with servo	22,2 mm (0.875 in.)
109 models, all	25,4 mm (1.000 in.)

WHEELS

Size	
88 models	5.00F × 16
109 models	5.50F × 16
109 One ton models	6.50L × 16

TYRES

Type/Size	
88 models: Standard	Cross Ply 6.00-16
Optional	Cross Ply 6.50-16
	Cross Ply 7.00-16
	Cross Ply 7.50-16 with 5.50F X 16 wheel
109 models	Cross Ply 7.50-16
109 One ton model	Cross Ply 9.00-16

Tyre pressures

Model		Normal Conditions		Emergency Soft	
		Front	Rear	Front	Rear
88 inch Wheelbase 6.00, 6.50 and 7.00 X 16	kg/cm ²	1.76	2.11	1.05	1.4
	lb/in ²	25	30	15	20
	bars	1.72	2.07	1.03	1.38
88 inch Wheelbase 7.50 X 16	kg/cm ²	1.76	2.11	0.84	1.4
	lb/in ²	25	30	12	20
	bars	1.72	2.07	0.83	1.38
88 inch Wheelbase 205 X 16	kg/cm ²	1.76	2.46	1.05	1.76
	lb/in ²	25	35	15	25
	bars	1.72	2.41	1.03	1.72
109 inch Wheelbase 7.50 X 16 For speeds up to 70mph	kg/cm ²	1.76	2.53	1.05	1.83
	lb/in ²	25	36	15	26
	bars	1.72	2.48	1.03	1.79
109 One Ton 9.00 X 16	kg/cm ²	1.4	1.4	0.7	0.7
	lb/in ²	20	20	10	10
	bars	1.38	1.38	0.7	0.7

General Notes

Emergency soft pressures should only be used in extreme conditions where loss of traction is likely to occur. Return pressures to normal immediately the difficulties have been overcome.

The pressures quoted above are for laden and unladen conditions.
For extra ride comfort, the following can apply (road condition only)

88 models — less than 900kg on rear axle, lower tyre pressure to 1.76 kg/cm² — 25lb/in² — 1.72 bars
109 models — less than 1050kg on rear axle, lower tyre pressure to 1.76 kg/cm² — 25 lb/in² — 1.72 bars

Where special tyres or tyres other than the above are fitted to the vehicle, consult your Land Rover Distributor or Dealer or the tyre Manufacturer for correct tyre pressures.

ELECTRICAL EQUIPMENT

System	12 volt, negative earth	
Battery		
Petrol models: Basic	Chloride (6TWL921) 291	} Unipart GBY 2209
	Lucas (OCP/9/11) 371	
Heavy duty	Chloride (6TWZ13R) 369	} Unipart GBY 2240
	Lucas (OCP/13/11) 389	
Diesel models—heavy duty	Chloride (6TW15L) 243	Unipart GBY 2233
Alternator		
Type	16 ACR	
Nominal output	34 amps at 6000 Alternator rev/min	
Field resistance	4,33 ohms \pm 5%	
Brush spring pressure	5 to 10 ozs	
Brush minimum length	5,0 mm (0.2 in.) protruding beyond the brush box	
Stator	0,138 ohms \pm 5% at 20°C	
Rotor	3,27 ohms \pm 5% at 20°C	
Starter Motor		
Petrol models		
Make/type	Lucas 2M100	
Brush spring tension	1020 gms 36 ozs	
Brush minimum length	9,5 mm (0.375 in.)	
Diesel models		
Make/type	Lucas M45G Pre-engaged, oil and waterproof	
Brush spring tension	1,2 kg. (42 oz)	
Brush minimum length	8,0 mm (0.312 in.)	
Wiper motor		
Make/type	Lucas 14W single speed	
Armature end float	0,51 to 0,25 mm (0.002 in. to 0.010 in.)	
Brush minimum length	4,8 mm (0.190 in.)	
Brush spring tension	150g to 250g (5.3 ozs to 8 ozs)	
Resistance of armature winding at 16°C (60°F) measured between adjacent com- mutator segments	0.23 to 0.35 ohms	
Light running, rack disconnected		
Current at 13.5 V	1.4 amps max	
Speed 30 to 60 seconds from cold	46 to 52 rev/min	

GENERAL DIMENSIONS

	88		88 Station Wagon		109		109 Station Wagon		High Capacity Pick-up 2710 and 3020Kg Gross Vehicle Weight	
	Metric	British	Metric	British	Metric	British	Metric	British	Metric	British
Overall length	3,62 m	142.567 in.	3,62 m	142.56 in.	4,44 m	175 in.	4,44 m	175 in.	4,64 m	182.7 in.
Overall width (all models)	1,69 m	66.6 in.	—	—	—	—	—	—	1,72 m	67.7 in.
Overall unladen height, hood up	1,97 m	77.5 in.	—	—	—	—	—	—	2,03 m	80.0 in.
Overall unladen height, hood down, screen up	1,73 m	68 in.	—	—	—	—	—	—	—	—
Overall unladen height, hood down, screen down	1,46 m	57.5 in.	—	—	—	—	—	—	—	—
Overall unladen height, with cab or hard top	1,95 m	76.875 in.	1,98 m	77.875 in.	2,06 m	81 in.	2,07 m	81.375 in.	2,77 m	109 in.
Wheelbase	2,23 m	88 in.	2,23 m	88 in.	2,77 m	109 in.	2,77 m	109 in.	—	—
Track	1,31 m	51.5 in.	1,31 m	51.5 in.	1,33 m	52.5 in.	1,53 m	52.5 in.	—	—
Turning circle	11,6 m	38 ft.	11,6 m	38 ft.	14,3 m	47 ft.	14,3 m	47 ft.	14,3 m	47 ft.
Unladen ground clearance under differen- tials, 6.00 X 16 tyres	178 mm	7 in.	178 mm	7 in.	—	—	—	—	—	—
Unladen ground clearance under differen- tials, 7.00 X 16 tyres	197 mm	7.75 in.	197 mm	7.75 in.	—	—	—	—	—	—
Unladen ground clearance under differen- tials, 7.50 X 16 tyres	—	—	—	—	209 mm	8.25 in.	209 mm	8.25 in.	209 mm	8.25 in.
Internal body dimensions:										
Length (between cappings)	1,206 m	47.5 in.	—	—	1,85 m	72.75 in.	—	—	—	—
Width (between cappings)	1,45 m	57 in.	—	—	1,45 m	57 in.	—	—	—	—
Height of body sides	508 mm	20 in.	—	—	495 mm	19.5 in.	—	—	—	—
Height of wheel arch	216 mm	8.5 in.	—	—	229 mm	9 in.	—	—	—	—
Width of wheel arch (to body side)	292 mm	11.5 in.	—	—	349 mm	13.75 in.	—	—	—	—
Width of floor (between wheel arches)	921 mm	36.25 in.	—	—	921 mm	36.25 in.	—	—	—	—
Height, floor to roof (maximum)	1,23 mm	48.5 in.	—	—	1,22 m	48 in.	—	—	—	—

WEIGHTS**Short-wheelbase weights**

	Full Length Canvas Hood				Truck Cab				Hard Top				Station Wagon				
	Petrol		Diesel		Petrol		Diesel		Petrol		Diesel		Petrol		Diesel		
	kg	lb	kg	lb	kg	lb	kg	lb	kg	lb	kg	lb	kg	lb	kg	lb	
UNLADEN WEIGHT																	
Front axle	718	1583	747	1647	725	1599	754	1663	713	1572	742	1636	705	1555	734	1619	
Rear axle	580	1279	589	1299	582	1283	591	1303	625	1378	634	1398	713	1572	722	1592	
Total	1298	2862	1336	2946	1307	2882	1345	2966	1338	2950	1376	3034	1418	3127	1456	3211	
EEC KERB WEIGHT																	
Front axle	756	1667	786	1733	763	1682	793	1749	751	1656	781	1722	743	1638	773	1705	
Rear axle	650	1433	661	1457	652	1438	663	1462	695	1532	706	1557	783	1727	794	1751	
Total	1406	3100	1447	3190	1415	3120	1456	3211	1446	3188	1487	3279	1526	3365	1567	3456	
GROSS VEHICLE WEIGHT																	
Front axle	930 2051		930 2051		930 2051		930 2051		930 2050		930 2050		930 2050		930 2050		
Rear axle	1190 2624		1190 2624		1190 2624		1190 2624		1190 2624		1190 2624		1190 2624		1190 2624		
Total	2120 4675		2120 4675		2120 4675		2120 4675		2120 4674		2120 4674		2120 4674		2120 4674		

NOTE: Unladen weight is the minimum vehicle specification—excluding fuel and driver.

EEC kerb weight is the minimum vehicle specification—plus full fuel tank and 75 kg (165 lb) driver.

Gross vehicle weight is the maximum all-up weight including driver, passengers, payload and equipment.

NOTE: For sustained cross-country use the gross vehicle weight must be reduced by 90 kg (off the rear axle).

Maximum Permissible Towed Weights	On-road		Off-road	
	kg	lb	kg	lb
Trailers without brakes	500	1100	500	1100
Trailers with over-run brakes	2000	4400	1000	2200
4-wheel trailers with continuous or semi-continuous brakes, i.e. coupled brakes	3500	7700		
	(Petrol)			
	3500 7700		1000	2200
	(Diesel)			

NOTE: The weights above do not authorise use outside the legislation enforced by the territory in which the vehicle and trailer combination is being operated.

Long-wheelbase weights

	Full Length Canvas Hood				Truck Cab				Hard Top				12-seater Station Wagon				2710 kg Gross vehicle weight		3020 kg Gross vehicle weight	
	4-cylinder Petrol		4-cylinder Diesel		4-cylinder Petrol		4-cylinder Diesel		4-cylinder Petrol		4-cylinder Diesel		4-cylinder Petrol		4-cylinder Diesel		4-cylinder Petrol		4-cylinder Diesel	
	kg	lb	kg	lb	kg	lb	kg	lb	kg	lb	kg	lb	kg	lb	kg	lb	kg	kg	kg	kg
UNLADEN WEIGHT																				
Front axle	785	1733	814	1795	794	1751	823	1815	786	1733	815	1797	788	1797	819	1806	799	812	818	831
Rear axle	700	1544	712	1570	694	1530	706	1557	744	1641	756	1667	891	1965	890	1962	720	732	744	756
Total	1485	3277	1526	3365	1488	3281	1529	3372	1530	3374	1571	3464	1679	3702	1709	3768	1519	1544	1562	1587
EEC KERB WEIGHT																				
Front axle	811	1788	839	1850	820	1808	848	1870	812	1790	840	1852	814	1795	844	1861	825	837	844	856
Rear axle	798	1760	819	1806	792	1746	813	1793	842	1857	863	1903	989	2181	997	2198	818	839	842	863
Total	1609	3548	1658	3656	1612	3554	1661	3663	1654	3647	1703	3755	1803	3976	1841	4059	1643	1676	1686	1719
GROSS VEHICLE WEIGHT																				
Front axle	1000 2205		1000 2205		1000 2205		1000 2205		1000 2205		1000 2205		1000 2205		1000 2205		1000		1120	
Rear axle	1710 3771		1710 3771		1710 3771		1710 3771		1710 3771		1710 3771		1710 3771		1710 3771		1710		1900	
Total	2710 5976		2710 5976		2710 5976		2710 5976		2710 5976		2710 5976		2710 5976		2710 5976		2710		3020	

High Capacity Pick-Up Weights

ENGINE TUNING DATA

ENGINE

2¼ litre 4-cylinder Petrol models (Refer to Division 17 for emission controlled engines)

Type	In line four cylinder four stroke, overhead valves
Capacity	2286 cm ³ (139.5 in. ³).
Compression ratio	
Standard	8.0:1 (Engine number commencing 901....)
Optional	7.0:1 (Engine number commencing 904....)
Firing Order	1-3-4-2
Compression pressure	
8.0:1 compression ratio	11,2 kgf. cm ² (160 lbf. in. ²)
7.0:1 compression ratio	10,2 kgf. cm ² (145 lbf. in. ²)
Idling speed	500 rev/min
Fast idle setting	1,40 mm (0.055 in.) throttle butterfly clearance, 1200 ± 50 rev/min
Ignition timing, static	
8.0:1 compression ratio	TDC when using 90 octane fuel 3° ATDC when using 85 octane fuel
7.0:1 compression ratio	3° BTDC when using 83 octane fuel TDC when using 75 octane fuel
Timing marks	On crankshaft pulley
Valve clearance, inlet and exhaust	0,25 mm (0.010 in.)

DISTRIBUTOR

Make/type	Lucas 45D
Rotation of rotor	Anti-clockwise
Contact breaker gap	0,36 mm to 0,40 mm (0.014 in. to 0.016 in.)
Condenser capacity	0.2 microfarad
Serial number	5069

Centrifugal advance with TDC ignition timing

Decelerating check with vacuum unit disconnected

Crankshaft angle	Engine rev/min
38° to 42°	4500
30° to 34°	3500
22° to 26°	2500
12° to 16°	1200
4° to 12°	900
0° to 4°	600
No advance below	450

Vacuum advance

Starts	89 mm (3.5 in.) Hg.
Finishes	635 mm (25.0 in.) Hg.

SPARKING PLUGS

Make/type	
8.0:1 compression ratio	Champion N12Y or Unipart GSP 131
7.0:1 compression ratio	Champion N8 or Unipart GSP 130
Gap	0,75 to 0,80 mm (0.029 to 0.032 in.)

IGNITION COIL

Make/type	HA12
Primary resistance at 20°C (68°F)	3.0 to 3.5 ohms
Consumption—ignition on at engine idle speed	2.0 amps approx.

CARBURETTER

Make/type	Zenith 361V
Choke diameter	27 mm
Main jet	125
Compensating (enrichment) jet	150
Pump jet	65 (short stroke, outer hole)
Needle valve	1.75

High altitude carburetter

Main	(120)	Altitude: 1524 to 2133 m (5000 to 7000 ft)
	(117.5)	2133 to 2743 m (7000 to 9000 ft)
	(115)	2743 to 3657 m (9000 to 12000 ft)
	(112.5)	3657 to 4267 m (12000 to 14000 ft)
Slow running	(55)	2743 to 4267 m (9000 to 14000 ft)

ENGINE

2¼ litre 4-cylinder Diesel models

Type	In line four cylinder four stroke, overhead valves
Capacity	2286 cm ³ (139.5 in. ³)
Compression ratio	23.0:1
Firing order	1-3-4-2
Idling speed	590 ± 20 rev/min
Injection timing setting	13° B.T.D.C.
Timing marks	
Valve timing — inlet and exhaust	
Injection timing	On engine flywheel and pump flange
Valve clearance — inlet and exhaust	0,25 mm (0,010 in)

INJECTORS

Make/type	CAV Pintaux
Nozzle size	BDNO/SPC 6209
Opening pressure	135 Atm

HEATER PLUGS

Make/type	KLK GF 210/T or Champion AG45
-----------------	-------------------------------

DISTRIBUTOR PUMP

Make/type	CAV type DPA
Direction of rotation	Clockwise, viewed from drive end
Maximum speed setting (sealed)	4,200 engine rev/min

ENGINE

2.6 litre 6-cylinder Petrol models

Type	In line six cylinder four stroke, inlet-overhead valves exhaust-side valves
Capacity	2625 cm ³ (160.3 in. ³)
Compression ratio	
Standard	7.8:1 (Engine number commencing 941....)
Optional	7.0:1 (Engine number commencing 944....)
Firing order	1-5-3-6-2-4
Compression pressure	
7.8:1 compression ratio	9,48 to 10,5 kgf/cm ² (135 to 150 lbf/in. ²) at 3000 rev/min crank speed
7.0:1 compression ratio	9,84 kgf/cm ² (140 lbf/in. ²)
Idling speed	500 rev/min
Fast idle setting	1000 to 1200 rev/min
Ignition timing, static and dynamic	
7.8:1 compression ratio	2° ATDC when using 90 octane fuel 6° ATDC when using 85 octane fuel
7.0:1 compression ratio	2° BTDC when using 83 octane fuel TDC when using 80 octane fuel
Timing marks	On crankshaft pulley
Valve clearance	
Inlet	0,15 mm (0.006 in.) engine hot
Exhaust	0,25 mm (0.010 in.) engine hot or cold

DISTRIBUTOR

Make/type	Lucas 25D6
Rotation of rotor	Anti-clockwise

Centrifugal advance

Decelerating check with vacuum unit disconnected

Crankshaft angle	Engine rev/min
30° to 34°	4000
26° to 28°	3000
18° to 24°	1800
10° to 16°	1400
4° to 8°	800
0° to 4°	600
No advance below	400

Vacuum advance

Starts	165 mm (6.5 in.) Hg.
Finishes	635 mm (25.0 in.) Hg.

SPARKING PLUGS

Make/type	Champion N5 or Unipart GSP 160 (7.8:1 and 7.0:1 compression ratio)
Gap	0,75 to 0,80 mm (0.029 to 0.032 in.)

IGNITION COIL

Make/type	Lucas HA12
Primary resistance at 20°C (68°F)	3.0 to 3.5 ohms
Consumption-ignition on at engine idle speed	1.5 amps

CARBURETTER

	Zenith-Stromberg 175CD-SE
Choke diameter	41,275 mm (1.625 in.)
Metering needle	B18362.Z/4J
Air valve return spring	B18277.Z
Needle valve	B18353.Z 1,75 mm
Fast idle interconnection setting	1,1 mm or No. 57 drill at edge of throttle
Float height	16 mm to 17 mm (0.629 in. to 0.669 in.)

TORQUE WRENCH SETTINGS

	kgf. m.	lbf. ft.
ENGINE—2¼ litre 4-cylinder		
Connecting rod cap nuts	3,5	25
Main bearing cap bolts:		
Petrol engines—3 bearing	11,5	85
Diesel engines	13,8	100
Cylinder head bolts:		
Petrol engines		
5/16 in. UNF	2,4	18
1/2 in. UNF	8,9	65
Diesel engines		
5/16 in. UNF	2,4	18
1/2 in. UNF	12,5	90
Rocker shaft bolts		
Petrol engines		
5/16 in. UNF	2,4	18
1/2 in. UNF	8,9	65
Diesel engines		
5/16 in. UNF	2,4	18
1/2 in. UNF	12,5	90
Starter dog:		
Petrol engines	27,6	200
Diesel engines	27,6	200
Flywheel bolts	8,5 to 9,0	60 to 65
Oil filter bolts:		
Canister to housing	1,66	12
Housing to cylinder block	3,45	25
Engine sump bolts	1,65	12
ENGINE—2.6 litre 6-cylinder Petrol		
Connecting rod cap nuts	2,8	20
Main bearing cap bolts	10,4	75
Cylinder head bolts		
3/8 in. (9,5 mm approximately) diameter	4,0	30
7/16 in. (11 mm approximately) diameter	7,0	50
Starter dog	27,65	200
Flywheel bolts	8,5 to 9,0	60 to 65
Sump bolts	1,65	12
Fuel system		
2¼ litre 4-cylinder Diesel		
Injector nuts	0,8 to 1,0	6 to 8
Manifold and exhaust system		
2¼ litre 4-cylinder Petrol		
Induction manifold to exhaust manifold nuts	2,3	17
Clutch		
Clutch cover bolts	2,48 to 3,04	18 to 25

	kgf. m.	lbf. ft.
Gearbox		
Output drive flange nut	11,75	85
Layshaft bolt	7,00	50 (apply Loctite 601)
Rear axle and final drive		
Hub driving flange bolts	4,2 to 5,2	30 to 38
Salisbury type axles:		
Differential case bolts	9,1 to 10,4	66 to 75
Crownwheel bolts	15,3 to 17,3	111 to 125
Differential bearing cap bolts	12,9 to 14,5	93 to 105
Differential cover bolts	2,8 to 3,5	20 to 25
Rover type axles		
Bevel pinion driving flange nut	11,75	85
Crown wheel bolts	5,5 to 6,2	40 to 45
Differential bearing cap bolts	7,0 to 8,9	50 to 65
Hub driving flange nut	1,4 to 2,0	10 to 15
Front axle and final drive		
Hub driving flange bolts	4,2 to 5,2	30 to 38
Hub driving flange nut	2,0 to 2,7	15 to 20
Bevel pinion driving flange nut	11,75	85
Crown wheel bolts	5,5 to 6,2	40 to 45
Differential bearing cap bolts	7,0 to 8,9	50 to 65
Upper swivel pin bolts	7,0 to 8,9	50 to 65
Lower swivel pin nuts	7,0 to 8,9	50 to 65
Steering		
Steering wheel nut	5,4	40
Ball joint nuts	4,0	30
Relay lever pinch bolts	7,6	55
Steering box to support bracket bolts	7,0 to 8,5	50 to 60
Steering box support bracket to chassis bolts	2,0	15
Steering box drop arm nut	8,5 to 11,0	60 to 80
Road wheel nuts	10,3 to 11,7	75 to 85
Brakes		
Wheel cylinder bleed nipple	0,5 to 0,8	4 to 6
Master cylinder to servo nuts	2,2 to 2,6	16 to 19
Tipping valve retainer (Dual system master cylinder)	4,9 to 6,2	35 to 45
Brake failure switch end pipe union	2,2	16
Brake failure switch unit to housing	2,2	16
Fluid reservoir to master cylinder bolt (single line servo)	2,8 to 3,5	20 to 25
Fluid reservoir to master cylinder screws (dual line servo models)	0,3 to 0,4	2 to 3
Servo assembly securing nuts	1,2	9

continued

	kgf. m.	lbf. ft.
Suspension—all models		
Leaf spring 'U' bolts front and rear	8,0	58
Shackle nuts and bolts	8,3 to 9,7	60 to 70
Windscreen wipers and washers		
Wiper blade drive adaptor bolts	0,34 (34 kgf. cm)	2.5 (30 lbf. in.)
Electrical equipment		
Alternator shaft nut	3,5 to 4,2	25 to 30
Heater plugs (diesel)	3,4	25
Starter motor		
Petrol models		
Starter through bolts	1,0	8
Diesel models		
Solenoid to starter nuts	0,62	4.5
Solenoid outer terminal nuts	0,41	3
Starter yoke terminal outer nut ..	0,2	1.5
Starter through bolts	1,1	8
Starter earth stud nut	0,82	6
Eccentric pivot pin locknut	2,2	16

GENERAL FITTING INSTRUCTIONS

Precautions against damage

- 1 Always fit covers to protect wings before commencing work in engine compartment.
- 2 Cover seats and carpets, wear clean overalls and wash hands or wear gloves before working inside car.
- 3 Avoid spilling hydraulic fluid or battery acid on paint work. Wash off with water immediately if this occurs. Use Polythene sheets in boot to protect carpets.
- 4 Always use a recommended Service Tool, or a satisfactory equivalent, where specified.
- 5 Protect temporarily exposed screw threads by replacing nuts or fitting plastic caps.

Safety Precautions

- 1 Whenever possible use a ramp or pit when working beneath car, in preference to jacking. Chock wheels as well as applying hand brake.
- 2 Never rely on a jack alone to support car. Use axle stands or blocks carefully placed at jacking points to provide rigid location.
- 3 Ensure that a suitable form of fire extinguisher is conveniently located.
- 4 Check that any lifting equipment used has adequate capacity and is fully serviceable.
- 5 Inspect power leads of any mains electrical equipment for damage and check that it is properly earthed.
- 6 Disconnect earth (grounded) terminal of car battery.
- 7 Do not disconnect any pipes in air conditioning refrigeration system, if fitted, unless trained and instructed to do so. A refrigerant is used which can cause blindness if allowed to contact eyes.
- 8 Ensure that adequate ventilation is provided when volatile de-greasing agents are being used.

CAUTION: Fume extraction equipment must be in operation when trichloride, methylene chloride, chloroform, or perchlorethylene are used for cleaning purposes.

- 9 Do not apply heat in an attempt to free stiff nuts or fittings; as well as causing damage to protective coatings, there is a risk of damage to electronic equipment and brake lines from stray heat.
- 10 Do not leave tools, equipment, spilt oil etc., around or on work area.
- 11 Wear protective overalls and use barrier creams when necessary.

Preparation

- 1 Before removing a component, clean it and its surrounding areas as thoroughly as possible.
- 2 Blank off any openings exposed by component removal, using greaseproof paper and masking tape.

- 3 Immediately seal fuel, oil or hydraulic lines when separated, using plastic caps or plugs, to prevent loss of fluid and entry of dirt.
- 4 Close open ends of oilways, exposed by component removal, with tapered hardwood plugs or readily visible plastic plugs.
- 5 Immediately a component is removed, place it in a suitable container; use a separate container for each component and its associated parts.
- 6 Before dismantling a component, clean it thoroughly with a recommended cleaning agent; check that agent is suitable for all materials of component.
- 7 Clean bench and provide marking materials, labels, containers and locking wire before dismantling a component.

Dismantling

- 1 Observe scrupulous cleanliness when dismantling components, particularly when brake, fuel or hydraulic system parts are being worked on. A particle of dirt or a cloth fragment could cause a dangerous malfunction if trapped in these systems.
- 2 Blow out all tapped holes, crevices, oilways and fluid passages with an air line. Ensure that any O-rings used for sealing are correctly replaced or renewed, if disturbed.
- 3 Mark mating parts to ensure that they are replaced as dismantled. Whenever possible use marking ink, which avoids possibilities of distortion or initiation of cracks, liable if centre punch or scriber are used.
- 4 Wire together mating parts where necessary to prevent accidental interchange (e.g. roller bearing components).
- 5 Wire labels on to all parts which are to be renewed, and to parts requiring further inspection before being passed for reassembly; place these parts in separate containers from those containing parts for rebuild.
- 6 Do not discard a part due for renewal until after comparing it with a new part, to ensure that its correct replacement has been obtained.

Inspection—General

- 1 Never inspect a component for wear or dimensional check unless it is absolutely clean; a slight smear of grease can conceal an incipient failure.
- 2 When a component is to be checked dimensionally against figures quoted for it, use correct equipment (surface plates, micrometers, dial gauges, etc.) in serviceable condition. Makeshift checking equipment can be dangerous.
- 3 Reject a component if its dimensions are outside limits quoted, or if damage is apparent. A part may, however, be refitted if its critical dimension is exactly limit size, and is otherwise satisfactory.

- 4 Use 'Plastigauge' 12 Type PG-1 for checking bearing surface clearances; directions for its use, and a scale giving bearing clearances in 0.0001 in. (0,0025 mm.) steps are provided with it.

Ball and Roller Bearings

NEVER REPLACE A BALL OR ROLLER BEARING WITHOUT FIRST ENSURING THAT IT IS IN AS-NEW CONDITION.

- 1 Remove all traces of lubricant from bearing under inspection by washing in petrol or a suitable de-greaser; maintain absolute cleanliness throughout operations.
- 2 Inspect visually for markings of any form on rolling elements, raceways, outer surface of outer rings or inner surface of inner rings. Reject any bearings found to be marked, since any marking in these areas indicates onset of wear.
- 3 Holding inner race between finger and thumb of one hand, spin outer race and check that it revolves absolutely smoothly. Repeat, holding outer race and spinning inner race.
- 4 Rotate outer ring gently with a reciprocating motion, while holding inner ring; feel for any check or obstruction to rotation, and reject bearing if action is not perfectly smooth.
- 5 Lubricate bearing generously with lubricant appropriate to installation.
- 6 Inspect shaft and bearing housing for discoloration or other marking suggesting that movement has taken place between bearing and seatings. (This is particularly to be expected if related markings were found in operation 2.) If markings are found, use 'Loctite' in installation of replacement bearing.
- 7 Ensure that shaft and housing are clean and free from burrs before fitting bearing.
- 8 If one bearing of a pair shows an imperfection it is generally advisable to renew both bearings: an exception could be made if the faulty bearing had covered a low mileage, and it could be established that damage was confined to it only.
- 9 When fitting bearing to shaft, apply force only to inner ring of bearing, and only to outer ring when fitting into housing.

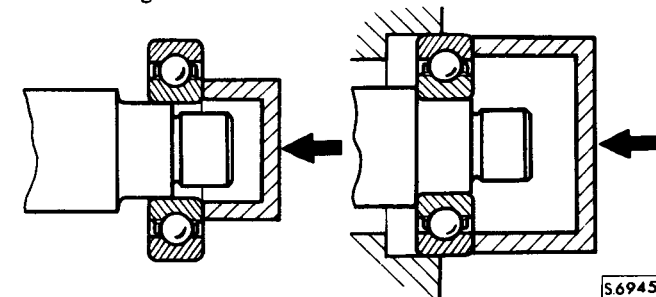

5.6945

- 10 In the case of grease-lubricated bearings (e.g. hub bearings) fill space between bearing and outer seal with recommended grade of grease before fitting seal.
- 11 Always mark components of separable bearings (e.g. taper roller bearings) in dismantling, to ensure correct reassembly. Never fit new rollers in a used cup.

Oil Seals

- 1 Always fit new oil seals when rebuilding an assembly. It is not physically possible to replace a seal exactly when it has bedded down.
- 2 Carefully examine seal before fitting to ensure that it is clean and undamaged.
- 3 Smear sealing lips with clean grease; pack dust excluder seals with grease, and heavily grease duplex seals in cavity between sealing lips.
- 4 Ensure that seal spring, if provided, is correctly fitted.
- 5 Place lip of seal towards fluid to be sealed and slide into position on shaft, using fitting sleeve when possible to protect sealing lip from damage by sharp corners, threads or splines. If fitting sleeve is not available, use plastic tube or adhesive tape to prevent damage to sealing lip.

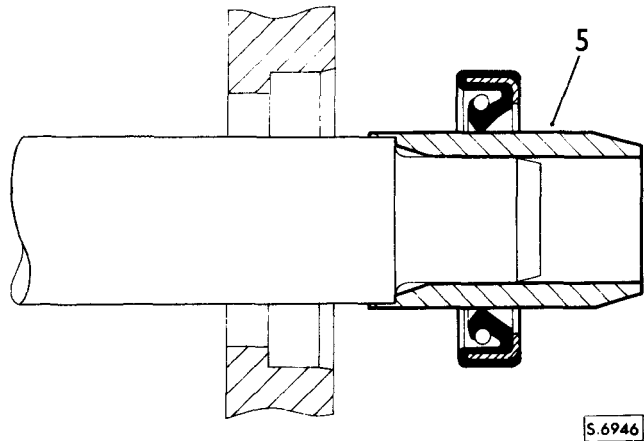

- 6 Grease outside diameter of seal, place square to housing recess and press into position, using great care and if possible a 'bell piece' to ensure that seal is not tilted. (In some cases it may be preferable to fit seal to housing before fitting to shaft.) Never let weight of unsupported shaft rest in seal.

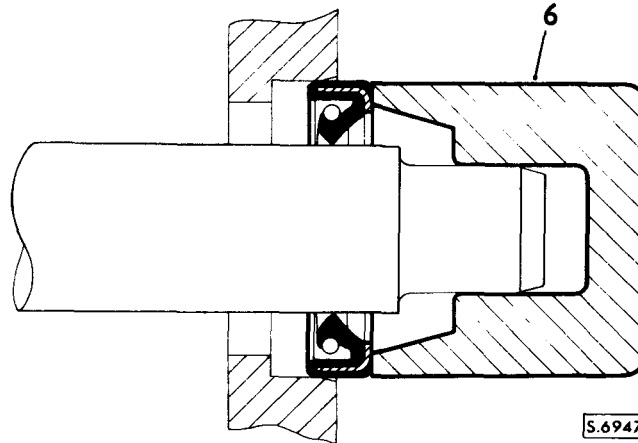

- 7 If correct service tool is not available, use a suitable drift approximately 0.015 in. (0,4 mm) smaller than outside diameter of seal. Use a hammer VERY GENTLY on drift if a press is not suitable.
- 8 Press or drift seal in to depth of housing if housing is shouldered, or flush with face of housing where no shoulder is provided.

NOTE: Most cases of failure or leakage of oil seals are due to careless fitting, and resulting damage to both seals and sealing surfaces. Care in fitting is essential if good results are to be obtained.

Joints and Joint Faces

- 1 Always use correct gaskets where they are specified.
- 2 Use jointing compound only when recommended. Otherwise fit joints dry.
- 3 When jointing compound is used, apply in a thin uniform film to metal surfaces; take great care to prevent it from entering oilways, pipes or blind tapped holes.
- 4 Remove all traces of old jointing materials prior to reassembly. Do not use a tool which could damage joint faces.
- 5 Inspect joint faces for scratches or burrs and remove with a fine file or oil stone; do not allow swarf or dirt to enter tapped holes or enclosed parts.
- 6 Blow out any pipes, channels or crevices with compressed air, renewing any O-rings or seals displaced by air blast.

Flexible Hydraulic Pipes, Hoses

- 1 Before removing any brake or power steering hose, clean end fittings and area surrounding them as thoroughly as possible.
- 2 Obtain appropriate blanking caps before detaching hose end fittings, so that ports can be immediately covered to exclude dirt.
- 3 Clean hose externally and blow through with airline. Examine carefully for cracks, separation of plies, security of end fittings and external damage. Reject any hose found faulty.
- 4 When refitting hose, ensure that no unnecessary bends are introduced, and that hose is not twisted before or during tightening of union nuts.
- 5 Containers for hydraulic fluid must be kept absolutely clean.
- 6 Do not store hydraulic fluid in an unsealed container. It will absorb water, and fluid in this condition would be dangerous to use due to a lowering of its boiling point.
- 7 Do not allow hydraulic fluid to be contaminated with mineral oil, or use a container which has previously contained mineral oil.
- 8 Do not re-use fluid bled from system.
- 9 Always use clean brake fluid to clean hydraulic components.
- 10 Fit a blanking cap to a hydraulic union and a plug to its socket after removal to prevent ingress of dirt.
- 11 Absolute cleanliness must be observed with hydraulic components at all times.
- 12 After any work on hydraulic systems, inspect carefully for leaks underneath the car while a second operator applies maximum pressure to the brakes (engine running) and operates the steering.

continued

Metric Bolt Identification

- 1 An ISO metric bolt or screw, made of steel and larger than 6 mm in diameter can be identified by either of the symbols ISO M or M embossed or indented on top of the head.
- 2 In addition to marks to identify the manufacture, the head is also marked with symbols to indicate the strength grade e.g. 8.8, 10.9, 12.9 or 14.9, where the first figure gives the minimum tensile strength of the bolt material in tens of kg/sq. mm.
- 3 Zinc plated ISO metric bolts and nuts are chromate passivated, a greenish-khaki to gold-bronze colour.

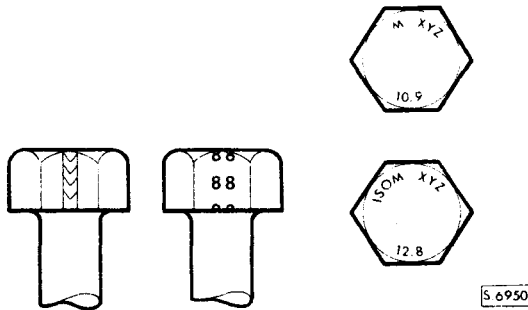

Metric Nut Identification

- 1 A nut with an ISO metric thread is marked on one face or on one of the flats of the hexagon with the strength grade symbol 8, 12 or 14. Some nuts with a strength 4, 5 or 6 are also marked and some have the metric symbol M on the flat opposite the strength grade marking.
- 2 A clock face system is used as an alternative method of indicating the strength grade. The external chamfers or a face of the nut is marked in a position relative to the appropriate hour mark on a clock face to indicate the strength grade.
- 3 A dot is used to locate the 12 o'clock position and a dash to indicate the strength grade. If the grade is above 12, two dots identify the 12 o'clock position.

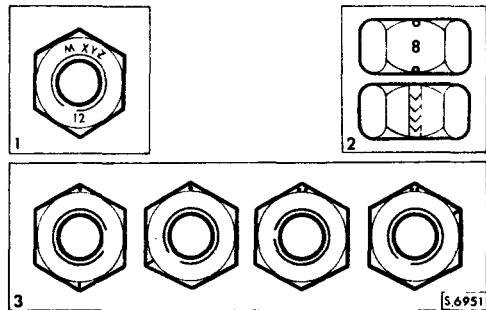

Hydraulic Fittings – Metrication

WARNING: Metric and Unified threaded hydraulic parts. Although pipe connections to brake system units incorporate threads of metric form, those for power assisted steering are of UNF type. It is vitally important that these two thread forms are not confused, and careful study should be made of the following notes.

Metric threads and metric sizes are being introduced into motor vehicle manufacture and some duplication of parts must be expected. Although standardisation must in the long run be good, it would be wrong not to give warning of the dangers that exist while UNF and metric threaded hydraulic parts continue together in service. Fitting UNF pipe nuts into metric ports and vice-versa should not happen, but experience of the change from BSF to UNF indicated that there is no certainty in relying upon the difference in thread size when safety is involved.

To provide permanent identification of metric parts is not easy but recognition has been assisted by the following means. (Illustration A Metric, B Unified.)

- 1 All metric pipe nuts, hose ends, unions and bleed screws are coloured black.
- 2 The hexagon area of pipe nuts is indented with the letter 'M'.
- 3 Metric and UNF pipe nuts are slightly different in shape.

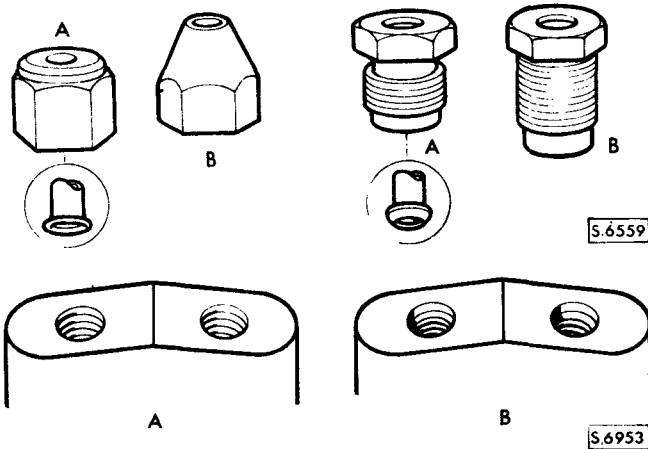

The metric female nut is always used with a trumpet flared pipe and the metric male nut is always used with a convex flared pipe.

- 4 All metric ports in cylinders and calipers have no counterbores, but unfortunately a few cylinders with UNF threads also have no counterbore. The situation is, all ports with counterbores are UNF, but ports not counterbored are most likely to be metric.

- 5 The colour of the protective plugs in hydraulic ports indicates the size and the type of the threads, but the function of the plugs is protective and not designed as positive identification. In production it is difficult to use the wrong plug but human error must be taken into account.

The Plug colours and thread sizes are:

	UNF
RED	$\frac{3}{8}$ " x 24 UNF
GREEN	$\frac{1}{8}$ " x 20 UNF
YELLOW	$\frac{1}{2}$ " x 20 UNF
PINK	$\frac{7}{8}$ " x 18 UNF

	METRIC
BLACK	10 x 1 mm
GREY	12 x 1 mm
BROWN	14 x 1.5 mm

- 6 Hose ends differ slightly between metric and UNF.

Gaskets are not used with metric hoses. The UNF hose is sealed on the cylinder or caliper face by a copper gasket by the metric hose seals against the bottom of the port and there is a gap between faces of the hose and cylinder. Pipe sizes for UNF are $\frac{3}{16}$ in., $\frac{1}{4}$ in., and $\frac{5}{16}$ in outside diameter.

Metric pipe sizes are 4.75 mm, 6 mm and 8 mm. 4.75 mm pipe is exactly the same as $\frac{3}{16}$ in. pipe. 6 mm pipe is .014 in. smaller than $\frac{1}{4}$ in. pipe. 8 mm pipe is .002 in. larger than $\frac{5}{16}$ in. pipe.

Convex pipe flares are shaped differently for metric sizes and when making pipes for metric equipment, metric pipe flaring tools must be used.

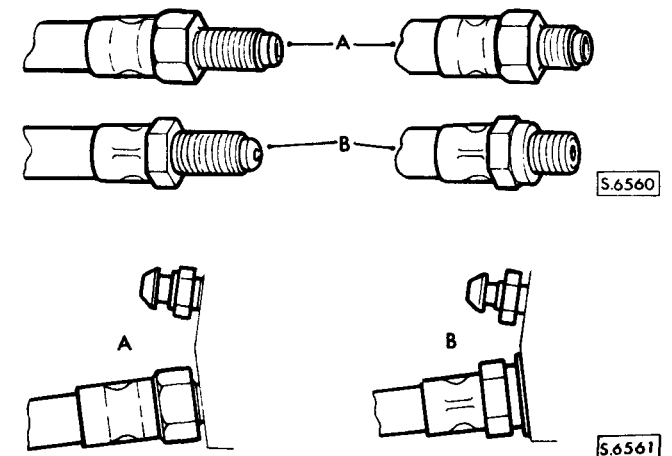

continued

The greatest danger lies with the confusion of 10 mm and in. UNF pipe nuts used for $\frac{3}{16}$ in. (or 4.75 mm) pipe. The in. UNF pipe nut or hose can be screwed into a 10 mm port but is very slack and easily stripped. The thread engagement is very weak and cannot provide an adequate seal.

The opposite condition, a 10 mm nut in a $\frac{3}{8}$ in. port, is difficult and unlikely to cause trouble. The 10 mm nut will screw in $1\frac{1}{2}$ or two turns and seize. It has a crossed thread 'feel' and it is impossible to force the nut far enough to seal the pipe. With female pipe nuts the position is of course reversed.

The other combinations are so different that there is no danger of confusion.

Keys and Keyways

- 1 Remove burrs from edges of keyways with a fine file and clean thoroughly before attempting to refit key.
- 2 Clean and inspect key closely; keys are suitable for refitting only if indistinguishable from new, as any indentation may indicate the onset of wear.

Tab Washers

- 1 Fit new washers in all places where they are used. Always renew a used tab washer.
- 2 Ensure that the new tab washer is of the same design as that replaced.

Split Pins

- 1 Fit new split pins throughout when replacing any unit.
- 2 Always fit split pins where split pins were originally used. Do not substitute spring washers: there is always a good reason for the use of a split pin.
- 3 All split pins should be fitted as shown unless otherwise stated.

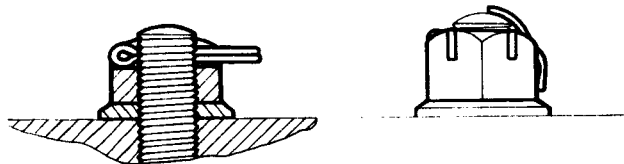

S.6948

Nuts

- 1 When tightening a slotted or castellated nut never slacken it back to insert split pin or locking wire except in those recommended cases where this forms part of an adjustment. If difficulty is experienced, alternative washers or nuts should be selected, or washer thickness reduced.
- 2 Where self-locking nuts have been removed it is advisable to replace them with new ones of the same type.

NOTE: Where bearing pre-load is involved nuts should be tightened in accordance with special instructions.

Locking Wire

- 1 Fit new locking wire of the correct type for all assemblies incorporating it.
- 2 Arrange wire so that its tension tends to tighten the bolt heads, or nuts, to which it is fitted.

Screw Threads

- 1 Both UNF and Metric threads to ISO standards are used. See below for thread identification.
- 2 Damaged threads must always be discarded. Cleaning up threads with a die or tap impairs the strength and closeness of fit of the threads and is not recommended.
- 3 Always ensure that replacement bolts are at least equal in strength to those replaced.
- 4 Do not allow oil, grease or jointing compound to enter blind threaded holes. The hydraulic action on screwing in the bolt or stud could split the housing.
- 5 Always tighten a nut or bolt to the recommended torque figure. Damaged or corroded threads can affect the torque reading.
- 6 To check or re-tighten a bolt or screw to a specified torque figure, first slacken a quarter of a turn, then re-tighten to the correct figure.
- 7 Always oil thread lightly before tightening to ensure a free running thread, except in the case of self-locking nuts.

Unified Thread Identification

1 Bolts

A circular recess is stamped in the upper surface of the bolt head.

2 Nuts

A continuous line of circles is indented on one of the flats of the hexagon, parallel to the axis of the nut.

3 Studs, Brake Rods, etc.

The component is reduced to the core diameter for a short length at its extremity.

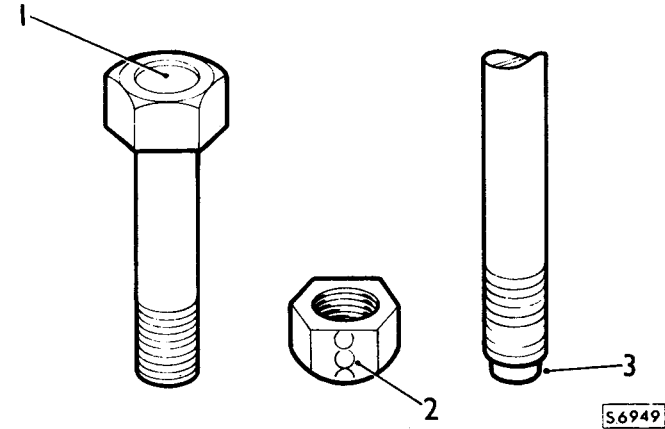

56949

SERVICE LUBRICANTS, FUEL, FLUIDS AND CAPACITIES

CAPACITIES

The following capacity figures are approximate and are provided as a guide only. All oil levels must be checked using the dipstick or level plug, as applicable with the vehicle on level ground.

	Litres	Imperial unit	US unit
Engine sump oil, 4-cylinder	6,0	11 pints	13 pints
Engine sump oil, 6-cylinder	6,8	12 pints	14 pints
Extra when refilling after fitting new filter, 4-cylinder	0,85	1.5 pints	1.8 pints
Extra when refilling after fitting new filter, 6-cylinder	0,5	1 pint	1.2 pints
Air cleaner oil, 4-cylinder	0,85	1.5 pints	1.8 pints
Air cleaner oil, 6-cylinder	0,5	1 pint	1.2 pints
Main gearbox oil	1,5	2.5 pints	3 pints
Transfer box oil	2,5	4.5 pints	5.5 pints
Rear differential)	1,75	3 pints	3.5 pints
Front differential) Rover	1,75	3 pints	3.5 pints
Rear differential: Salisbury 8HA	2,5	4.5 pints	5.5 pints
Swivel pin housing oil (each)	0,5	1 pint	1.2 pints
Fuel tank, 4-cylinder models except Station Wagon	45	10 gallons	12 gallons
Fuel tank, 6-cylinder models except Station Wagon	50	11 gallons	13 gallons
Fuel tank, 4-cylinder and 6-cylinder Station Wagon models	68	15 gallons	18 gallons
Cooling system, 4-cylinder Petrol models	8,1	14.25 pints	17.1 pints
Cooling system, 6-cylinder Petrol models	11,2	20 pints	24 pints
Cooling system, Diesel models	7,8	13.75 pints	16.5 pints
Hydraulic front winch, supply tank	20,0	4.5 gallons	7.5 gallons
Hydraulic front winch, gearbox	1,0	2 pints	2.4 pints

COMPONENT	SERVICE CLASSIFICATION
Fuel Tank	2½ litre Petrol models 7.0:1 compression ratio: 90 octane with 6° BTDC ignition timing 83 octane with 3° BTDC ignition timing 75 octane with TDC ignition timing 8.0:1 compression ratio: 90 octane with TDC ignition timing 85 octane with 3° ATDC ignition timing
	2.6 litre Petrol models 7.0:1 compression ratio: 83 octane with 2° BTDC ignition timing 80 octane with TDC ignition timing 78 octane with 2° ATDC ignition timing 7.8:1 compression ratio: 90 octane with 2° ATDC ignition timing 85 octane with 6° ATDC ignition timing
	2½ litre Diesel models Diesel fuel (D.E.R.V.)

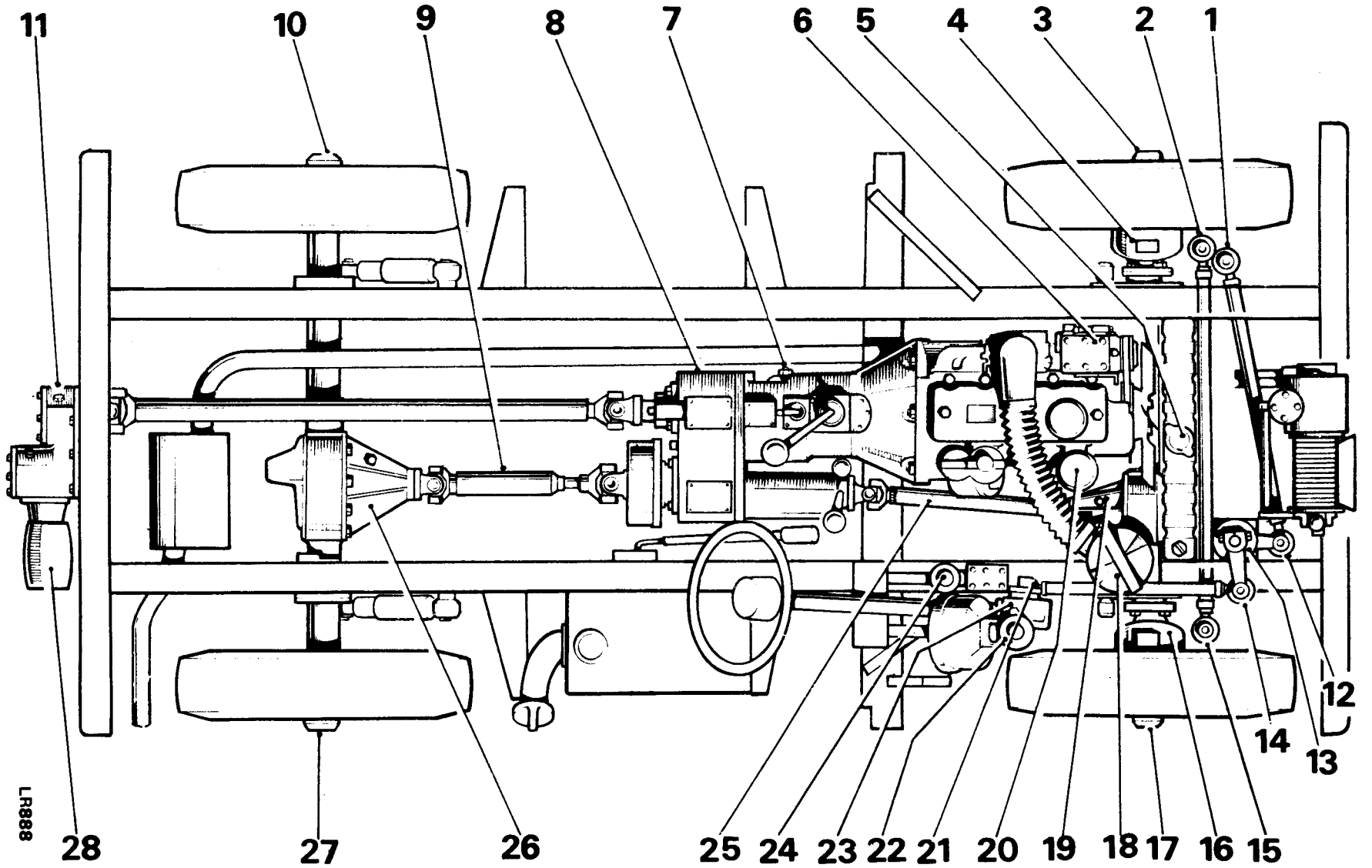

LR888

RECOMMENDED LUBRICANTS AND FLUIDS FOR BRITISH ISLES ALL YEAR ROUND USE

DIAGRAM NUMBER	COMPONENT	BP	DUCKHAMS	CASTROL	ESSO	MOBIL	PETROFINA	SHELL	TEXACO
20 18 6	Engine. Petrol Air cleaner Governor Hydraulic winch supply tank	BP Super Viscostatic 20—50 BP VF7	Duckhams Hypergrade Motor Oil (15W/50)	Castrol GTX (15W/50)	Esso Superlube (10W/40)	Mobil Super 15W/40 Mobil 1 (10W/30)	Fina Supergrade Motor Oil 15W/40 or 20W/50	Shell Super Motor Oil (15W/40)	Havoline Motor Oil 15W/40
20 18	Engine. Diesel Hydraulic winch supply tank Air cleaner	BP Super Viscostatic 20—50 or BP Vanellus C3 Multigrade 20W/50 BP VF7	Duckhams Hypergrade Motor Oil (15W/50)	Castrol GTX (15W/50) or Deusol RX Super 15W/40	Esso Superlube (10W/40) or Essolube HDX 20W/50	Mobil Super 15W/40 or Mobil 1 (10W/30) or Delvac Super 15W/40 or Delvac Special 20W/50	Fina Supergrade Motor Oil 15W/40 or Fina Delta Multigrade 20W/50	Shell Super Motor Oil (15W/40) or Shell Rotella SX 20W/40 or Rimulax 15W/40	Havoline Motor Oil 15W/40 or Ursa Oil LA 15W/40 or Eurotex Motor Oil HD 20W/50
7 8 19 26 16 4 23 13 11 28	Main gearbox Transfer box Front differential Rear differential Swivel housing, R.H. Swivel housing, L.H. Steering box Steering relay Rear power take-off Pulley unit Hydraulic winch gearbox	BP Gear Oil S.A.E. 90 EP	Duckhams Hypoid 90	Castrol Hypoy S.A.E. 90 EP	Esso Gear Oil GX 85W/90	Mobil Mobilube HD 90	Fina Pontonic MP S.A.E. 90	Shell Spirax 90 EP	Texaco Multigear Lubricant S.A.E. 90 EP
12 1 15 2 14 21 17 3 27 10 25 9	Drag-link ball joint, R.H. Drag-link ball joint, L.H. Track-rod ball joint, R.H. Track-rod ball joint, L.H. Longitudinal arm ball joint, front Longitudinal arm ball joint, rear Front hub, R.H. Front hub, L.H. Rear hub, R.H. Rear hub, L.H. Front propeller shaft Rear propeller shaft	BP Energrease L2	Duckhams LB 10	Castrol LM Grease	Esso Multipurpose Grease H	Mobil Mobilgrease MP	Fina Marson HTL 2	Shell Retinax A	Marfak All Purpose Grease
	Windscreen washers	UNIPART SCREEN WASHER FLUID—ALL SEASONS							
24 22	Clutch fluid reservoir Brake fluid reservoir	UNIPART UNIVERSAL BRAKE FLUID or other brake fluids having a minimum boiling point of 260°C (500°F) and complying with FMVSS 116 DOT 3.							
5	Engine cooling system	UNIPART UNIVERSAL ANTI-FREEZE. If this is not available use an ethylene glycol based anti-freeze (containing no methanol) with non-phosphate corrosion inhibitors suitable for use in cast iron engines to ensure the protection of the cooling system against frost and corrosion.							

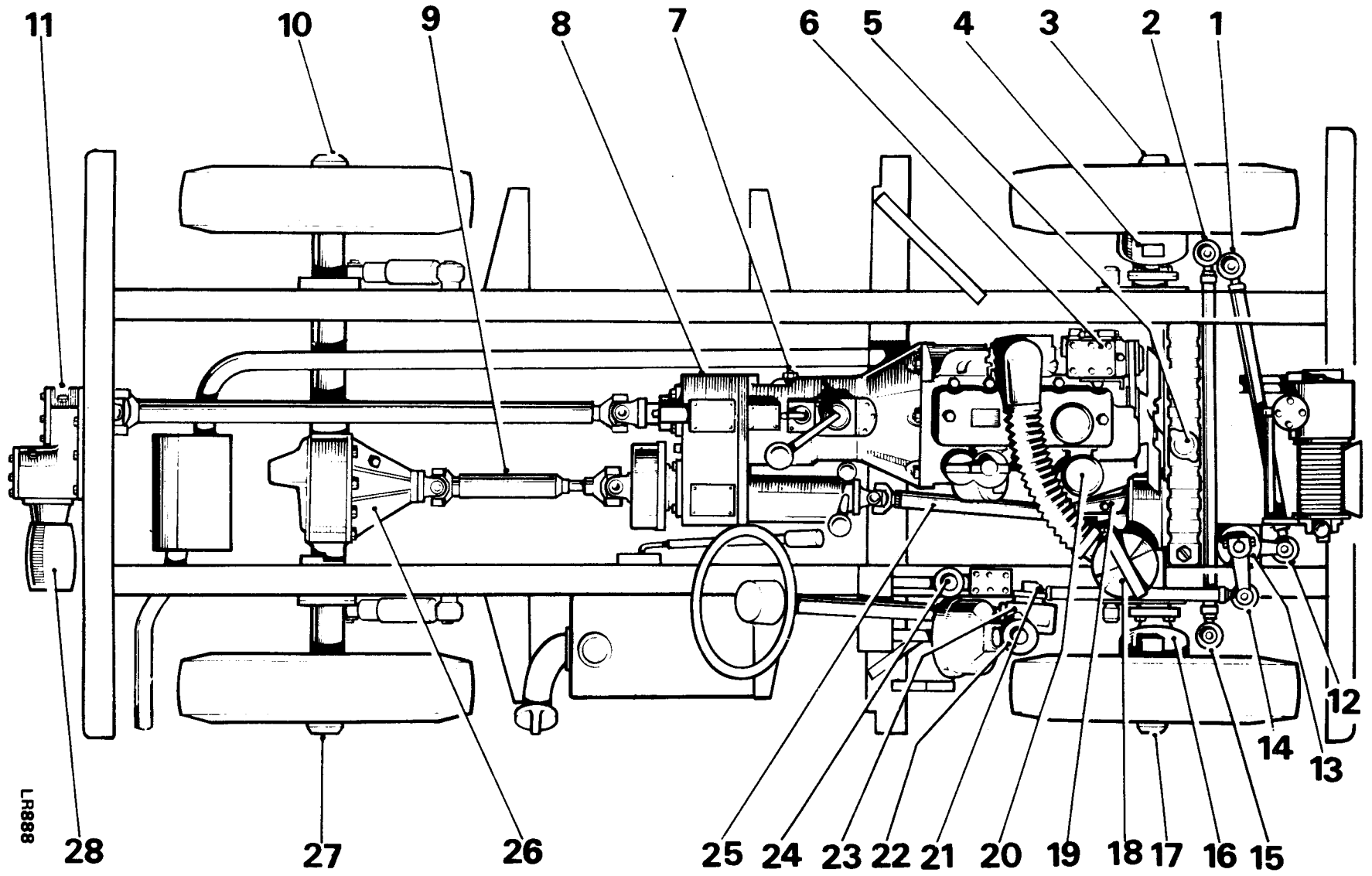

LR888

RECOMMENDED LUBRICANTS AND FLUIDS FOR OVERSEAS AND EXTREME TEMPERATURE CONDITIONS

DIAGRAM NUMBER	COMPONENT	SERVICE CLASSIFICATION		AMBIENT TEMPERATURE °C						
		PERFORMANCE LEVEL	S.A.E. VISCOSITY	-30	-20	-10	0	+10	+20	+30
20 6 18	Engine Governor Air cleaner Oil can Hydraulic winch supply tank	Oils must meet BL Cars Specification BLS.22.OL.02 or The CCMC Requirements or A.P.I. Service Rating Petrol Diesel SE or SF CC or CD or SE/CC or SE/CC or SF/CC or SE/CD or SE/CD or SF/CD or SF/CD or SF/CD	5W/20, 5W/30, 5W/40 10W/30 10W/40, 10W/50 15W/40, 15W/50 20W/40, 20W/50							
7 8 19 26 16 4 23 13 11 28	Main gearbox Transfer box Front differential Rear differential Swivel housing, R.H. Swivel housing, L.H. Steering box Steering relay Rear power take-off Pulley unit Hydraulic winch gearbox	A.P.I. GL4 or MIL-L-2105	90 EP 80W EP							
12 1 15 2 14 21 17 3 27 10 25 9	Drag-link ball joint, R.H. Drag-link ball joint, L.H. Track-rod ball joint, R.H. Track-rod ball joint, L.H. Longitudinal arm ball joint, front Longitudinal arm ball joint, rear Front hub, R.H. Front hub, L.H. Rear hub, R.H. Rear hub, L.H. Front propeller shaft Rear propeller shaft	NLGI-2 Multi-purpose lithium based grease								
	Windscreen washers	UNIPART SCREEN WASHER FLUID—ALL SEASONS, or other proprietary screen washer fluids.								
24 22	Clutch fluid reservoir Brake fluid reservoir	UNIPART UNIVERSAL BRAKE FLUID or other brake fluids having a minimum boiling point of 260°C (500°F) and complying with FMVSS 116 DOT 3.								
5	Engine cooling system	UNIPART UNIVERSAL ANTI-FREEZE. If this is not available use an ethylene glycol based anti-freeze (containing no methanol) with non-phosphate corrosion inhibitors suitable for use in cast iron engines to ensure the protection of the cooling system against frost and corrosion. When frost protection is not required use a non-phosphate corrosion inhibitor.								

MAINTENANCE SUMMARY CHART—EXCLUDING AUSTRALIA

KEY: MILEAGE × 1,000 MILES

Operation No.	Mileage
10.10.03	1
10.10.06	3, 9, 15, 21, 27, 33, 39, 45
10.10.12	6, 18, 30, 42
10.10.24	12, 24, 36, 48

Operation Number Intervals in Miles × 1000 Intervals in Kilometres × 1000	10.10.12	10.10.24
	6 10	12 20
ENGINE		
1 Check for oil leaks	X	X
2 Renew engine oil filter	X	X
3 Renew engine oil	X	X
4 Check crankcase breathing system for leaks, hoses for security and condition	X	X
5 Top-up carburettor piston damper(s) (2.6 only)	X	X
6 Check/adjust carburettor idle settings	X	X
7 Clean fuel pump sediment bowl (2¼ petrol only)		X
8 Check/adjust valve clearances		X
9 Check cooling and heater systems for leaks, and hoses for security and condition	X	X
10 Check/top-up cooling system	X	X
11 Check/adjust operation of all washers and top-up reservoirs	X	X
12 Check driving belts; adjust or renew	X	X
13 Lubricate accelerator control linkage and pedal pivot—check operation	X	X
14 Check security of engine mountings		X
15 Clean engine breather filter		X
16 Renew engine flame trap		X
17 Renew fuel filter element (2.6 only)		X
18 Clean fuel sedimenter (diesel)		X
19 Check air injection system hoses/pipes for security and condition (2.6 only)		X
20 Empty, clean and refill air cleaner oil bath		X
21 Drain flywheel housing if drain plug is fitted for wading	X	X
22 Check fuel injectors for burst pressure and test for spray		X
IGNITION		
23 Clean/adjust spark plugs	X	
24 Renew spark plugs		X
25 Check distributor points, adjust or renew	X	X
26 Lubricate distributor	X	X
27 Check/adjust ignition timing, using electronic equipment	X	X

Operation Number Intervals in Miles × 1000 Intervals in Kilometres × 1000	10.10.12	10.10.24
	6 10	12 20
TRANSMISSION		
28 Check for oil leaks	X	X
29 Check/top-up clutch fluid reservoir	X	X
30 Check tightness of prop. shaft coupling bolts		X
31 Lubricate propshaft(s)	X	X
32 Check/top-up gearbox oil	X	X
33 Check/top-up transfer box oil	X	X
34 Check/top-up front axle oil	X	X
35 Check/top-up rear axle/final drive oil	X	X
36 Check hydraulic clutch pipes and hoses visually for cracks, leaks and chafing	X	X
37 Clean axle breathers		X
STEERING AND SUSPENSION		
38 Check condition and security of steering unit joints, relays and gaiters	X	X
39 Check security of suspension fixings		X
40 Check/adjust front and rear wheel alignment	X	X
41 Check steering rack/gear for oil/fluid leaks	X	X
42 Check shock absorbers for fluid leaks	X	X
43 Check/top-up steering relay unit		X
44 Check/top-up steering box		X
45 Check/adjust steering box	X	X
46 Check/top-up swivel pin housing oil	X	X
BRAKES		
47 Check visually hydraulic pipes and unions for chafing, leaks and corrosion	X	X
48 Check/top-up brake fluid reservoir(s)	X	X
49 Check handbrake operation; adjust to manufacturer's instructions	X	X
50 Check footbrake operation; adjust to manufacturer's instructions (manual)	X	X
51 Inspect brake linings for wear, drums for condition	X	X
52 Lubricate handbrake mechanical linkage and cable guides (lever pivot)	X	X
53 Check brake servo hose(s) for security and condition	X	X
ELECTRICAL		
54 Check function of original equipment, i.e. interior and exterior lamps, horns, wipers and warning indicators	X	X
55 Check/top-up battery electrolyte	X	X
56 Clean and grease battery connections	X	X
57 Check/adjust headlamp alignment	X	X
58 Check, if necessary renew wiper blades	X	X
EXHAUST AND FUEL PIPES		
59 Check fuel system for leaks, pipes and unions for chafing and corrosion	X	X
60 Check exhaust system for leaks and security	X	X

MAINTENANCE SUMMARY CHART—EXCLUDING AUSTRALIA

Operation Number Intervals in Miles × 1000 Intervals in Kilometres × 1000	10.10.12	10.10.24
	6 10	12 20
WHEELS AND TYRES		
61 Check that tyres comply with manufacturer's specification	X	X
62 Check/adjust tyre pressures including spare	X	X
63 Check tyres for tread depth and visually for external cuts in fabric, exposure of ply or cord structure, lumps or bulges	X	X
64 Check tightness of road wheel fastenings	X	X
65 Check tyres for external cuts in tyre fabric, exposure of ply cord structure, lumps or bulges		
IMPORTANT: If tyres do not conform with legal requirements, report to owner.		
66 Interchange roadwheels (including spare)	X	X
BODY		
67 Lubricate all locks and hinges (NOT steering lock)	X	X
68 Check condition and security of seats and seat belts	X	X
69 Check rear view mirror(s) for cracks and crazing	X	X
70 Check operation of all door and bonnet locks		X
71 Check operation of window controls		X
72 Check operation of seat belt inertia reel mechanism	X	X
73 Ensure cleanliness of controls, door handles and steering wheel	X	X
GENERAL		
74 Road/Roller test and check function of all instrumentation	X	X
75 Report additional work required	X	X

At 24,000 mile (40,000 km) intervals, the following operations should be carried out:

- (i) Lubricate propeller shaft sealed sliding joints.
- (ii) Renew gearbox oil.
- (iii) Renew transfer box oil.
- (iv) Renew final drive unit(s) oil.
- (v) Renew swivel pin housing oil.

At 36,000 mile intervals – Renew air filter in brake servo unit.

At 48,000 mile intervals – Clean fuel pump filter (2.6 only)

BRAKES – PREVENTIVE MAINTENANCE

In addition to the recommended periodical inspection of brake components it is advisable, as the car ages, and as a precaution against the effects of wear and deterioration, to make a more searching inspection and renew parts as necessary. See page 10—18 for details.

MAINTENANCE SUMMARY CHART – AUSTRALIA ONLY – ADR27A – 2¼ PETROL

Detailed maintenance operations for specific emission control items are contained within section 17 of this manual.

MAINTENANCE INTERVALS

Service	Km x 1000	OPERATION NO.
A	1.6	10.10.03
B	5.15, 25, 35, 45, 55, 65, 75	10.10.06
C	10, 30, 50, 70	10.10.12
D	20, 60	10.10.24
E	40, 70	10.10.50

NOTE: The service schedules are based on an annual total of approximately 20,000 km. Should the vehicle complete substantially less kilometres than this per annum, it is recommended that a 'C' service is completed at six month intervals and a 'D' service at twelve month intervals.

Key to operation numbers and mileage intervals	A	B	C	D	E
	10. 10. 03	10. 10. 06	10. 10. 12	10. 10. 24	10. 10. 50
Operation Description					
Clean and test crankcase breather valve				X	
ENGINE					
Renew engine flame trap				X	X
Check/top up engine oil level		X			
Check/top up cooling system	X	X	X	X	X
Check/adjust operation of all washers and top up reservoirs	X	X	X	X	X
Renew engine oil	X		X	X	X
Renew engine oil filter			X	X	X
Lubricate accelerator control linkage (and pedal pivot) – check operation	X		X	X	X
Check cooling/heater system for leaks and hoses for security and condition	X	X	X	X	X
Check for oil leaks	X	X	X	X	X
Check/adjust torque of cylinder head nuts/bolts	X				
Check driving belts, adjust or renew	X			X	X
Check security of engine mountings	X			X	X
Check/adjust carburetter idle settings	X			X	X
Drain flywheel housing, if drain plug is fitted (for wading)		X	X	X	X
Check security of EGR valve operating lines	X			X	X
Check EGR system				X	X
Check/adjust choke settings (Manual chokes)	X			X	X
Check crankcase breathing system for leaks hoses/pipes for security and condition	X				

Key to operation numbers and mileage intervals	A	B	C	D	E
	10. 10. 03	10. 10. 06	10. 10. 12	10. 10. 24	10. 10. 50
Check crankcase breathing and evaporative loss systems; check hoses/pipes and restrictors for blockages, security and condition				X	X
Check/adjust valve clearances	X			X	X
Clean fuel pump sediment bowl	X			X	X
Check/adjust carburetter throttle prop	X			X	X
Empty, clean element, and refill air cleaner oil bath				X	X
Clean engine breather filter				X	
Renew engine breather filter				X	X
IGNITION					
Renew spark plugs				X	X
Lubricate distributor				X	X
Check/adjust ignition timing using electronic equipment	X			X	X
Check security of distributor vacuum unit line and operation of vacuum unit	X			X	X
Check ignition wiring for fraying, chafing and deterioration	X			X	X
Clean distributor cap, check for cracks and tracking				X	X
Check coil performance on oscilloscope				X	X
Renew distributor points				X	X
TRANSMISSION					
Check for oil leaks	X	X	X	X	X
Check/top up gearbox oil			X	X	
Check/top up rear axle/final drive oil			X	X	
Check tightness of propeller shaft coupling bolts	X			X	X
Lubricate propshaft(s)	X		X	X	X
Lubricate propshaft sealed sliding joint					X
Renew final drive unit(s) oil	X				X
Check/top up transfer box oil			X	X	
Check/top up front axle oil			X	X	
Renew transfer box oil	X				X
Check clutch pipes for leaks and chafing	X	X	X	X	X
Check/top up clutch fluid reservoir	X	X	X	X	X
Renew gearbox oil	X				X
Clean axle breathers					X

continued

MAINTENANCE SUMMARY CHART – AUSTRALIA ONLY

Key to operation numbers and mileage intervals	A	B	C	D	E
	10. 10. 03	10. 10. 06	10. 10. 12	10. 10. 24	10. 10. 50
STEERING AND SUSPENSION					
Check/top up swivel pin housing oil			X	X	
Check/adjust steering box	X	X	X	X	X
Check condition and security of steering unit joints relays and gaiters	X	X	X	X	X
Check security of suspension fixings	X			X	X
Check/adjust front and rear wheel alignment	X		X	X	X
Renew swivel pin housing oil	X			X	X
Check/top up steering relay unit				X	X
Check shock absorbers for fluid leaks	X	X	X	X	X
Check/top up steering box	X			X	X
Check steering rack/gear for oil/fluid leaks	X	X	X	X	X
BRAKES					
Inspect brake linings for wear and drums for condition			X	X	X
Check/top up brake fluid reservoirs	X	X	X	X	X
Check footbrake operations/adjust to manufacturer's instructions (Manual)	X		X	X	X
Check hand brake operation, adjust to manufacturer's instructions	X		X	X	X
Check brake servo hose(s) for security and condition	X	X	X	X	X
Lubricate hand brake mechanical linkage and cable guides			X	X	X
Check visually hydraulic pipes and unions for chafing, leaks and corrosion	X	X	X	X	X
ELECTRICAL					
Check function of original equipment, i.e. interior and exterior lamps, horns, wipers, and washers and warning indicators	X	X	X	X	X
Check/top up battery electrolyte	X	X	X	X	X
Clean and grease battery connections			X	X	X
Check/adjust headlamp alignment	X	X	X	X	X
Check, if necessary renew, wiper blades		X	X	X	X
Check output of charging system	X		X	X	X

Key to operation numbers and mileage intervals	A	B	C	D	E
	10. 10. 03	10. 10. 06	10. 10. 12	10. 10. 24	10. 10. 50
FUEL AND EXHAUST PIPES					
Check exhaust system for leaks and security	X	X	X	X	X
Check fuel system for leaks, pipes and unions for chafing and corrosion	X	X	X	X	X
Check condition of fuel filler cap seal				X	X
Renew fuel line filter				X	X
WHEELS AND TYRES					
Interchange road wheels (including spare)				X	X
Check/adjust tyre pressure including spare	X	X	X	X	X
Check that tyres comply with manufacturers specification			X	X	X
Check tightness of road wheel fastenings	X	X	X	X	X
Check tyres for external cuts in the fabric, exposure of ply or cord structure, lumps or bulges	X				
Check tyres for tread depth, visually for external cuts in fabric, exposure of ply or cord structure, lumps or bulges		X	X	X	X
*IMPORTANT – if tyres do not conform with legal requirements report to the owner					
BODY					
Lubricate all locks and hinges (not steering lock)	X		X	X	X
Check condition and security of seats and seat belts	X	X	X	X	X
Check rear view mirror for cracks and crazing		X	X	X	X
Check operation of all door, bonnet and boot locks	X			X	X
Check operation of window controls	X			X	X
Check operation of seat belt inertia reel mechanism	X	X	X	X	X
Ensure cleanliness of controls, door handles and steering wheel	X	X	X	X	X
ROAD TEST					
Road/roller test and check function of all instrumentation	X		X	X	X
Report additional work required		X	X	X	X

Additional work

At 60,000 km/3 year intervals which ever
is the sooner:-

Renew the air filter in the brake servo unit.

Engine oil level—All models

In addition to changing the oil and filter at the mileage intervals stated in the Maintenance Summary Chart, the oil level in the sump should be checked daily or weekly depending upon the conditions under which the vehicle is operating.

Proceed as follows:

- 1 Stand the vehicle on level ground and allow the oil to drain back into the sump.
- 2 Withdraw the dipstick, wipe it clean, re-insert to its full depth and remove a second time to take the reading. Add oil as necessary; never fill above the 'H' mark.
- 3 The oil level dipstick on 4-cylinder models carries three marks: 'H', 'L' and 'MIN L'. Under normal circumstances the oil level should not be allowed to fall below the minimum level mark 'MIN L'.
- 4 However, when the Land-Rover is being used at steep angles, the oil should not be allowed to fall below the intermediate mark 'L'. This will obviate any danger of oil pump starvation when the vehicle is facing downhill at a steep angle.

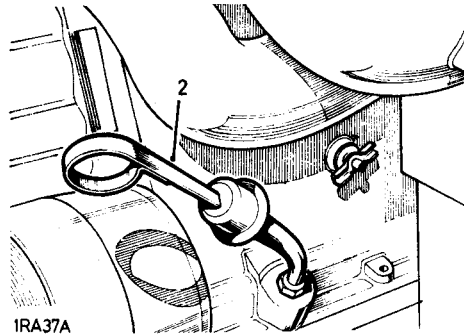

ENGINE

(1) Check for oil leaks in engine compartment; rectify as necessary

(2) & (3) Engine oil changes and filter replacement. Oil changes

To change the engine oil:

- 1 Run the engine to warm up the oil, then stop.
- 2 Remove the drain plug in the right-hand side of the sump. Allow oil to drain away completely and replace the plug.
To change filter located at right-hand side of engine on 4-cylinder models, left-hand side on 6-cylinder models.
- 3 Place oil tray under engine.
- 4 Unscrew the bolt from the filter adaptor.
- 5 Remove the container.
- 6 Remove the element.
- 7 Discard the used filter element and large rubber washer.
- 8 Wash the container in petrol.
- 9 Place the new filter element in the container and reassemble the unit, using the new large rubber washer supplied with the element.
- 10 Ensure that all the sealing washers are in position and intact, and that the container is correctly located in the adaptor.
Tighten the filter retaining bolt to 1,66 kgf m (12 lbf ft).
- 11 Refill with oil of the correct grade through the filler at the front of the engine; the total capacity including filter is: 4-cylinder models: 6,0 litres (11 Imperial pints) 12 US pints; 6-cylinder models: 5,5 litres (10 Imperial pints) 11 US pints.
- 12 Run engine and check for oil leaks at filter and drain plug.

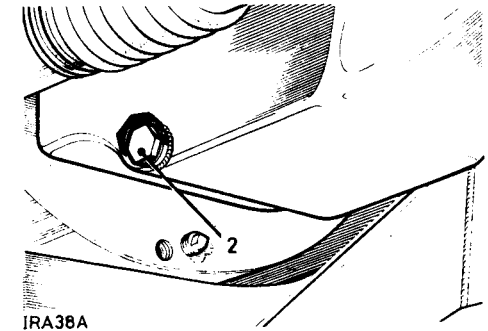

IRA38A

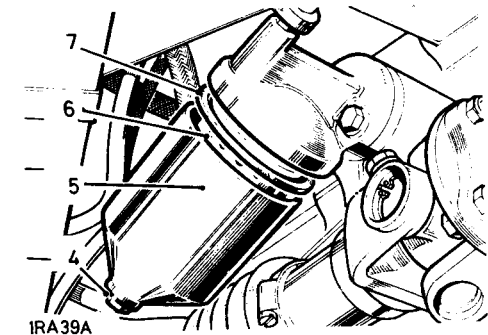

IRA39A

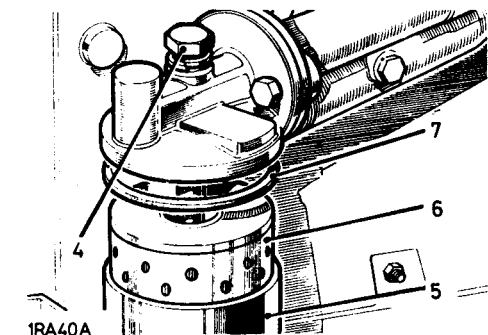

IRA40A

(4) Crankcase breathing system

Examine for leaks and change pipes or clips where necessary.

(5) Carburetter hydraulic damper—6-cylinder Petrol models

- 1 Unscrew the cap on top of the suction chamber, withdraw cap and hydraulic damper, replenish the damper reservoir as necessary with SAE 20 oil to within about 12 mm (0.5 in.) from the top of the tube. Then replace cap and hydraulic damper.

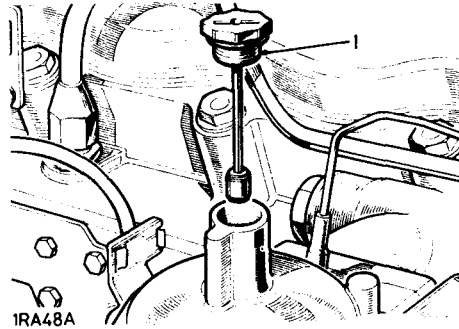
**(6) Carburetter slow-running adjustment—4-cylinder Petrol models. (Basic Carburetters only)**

The only adjustments provided at the carburetter are a throttle stop screw and a volume control screw.

Should the carburetter require adjustment for any reason, proceed as follows:

- 1 Run the engine until normal operating temperature is obtained. If necessary adjust the throttle stop screw to give the correct idling speed.
- 2 Adjust the volume control screw so that the engine will idle evenly with no tendency to stall on snap closure of the throttle.
- 3 Check that, as the throttle is opened slowly, there is a clear positive acceleration of the engine speed.
- 4 Finally, it may be necessary to re-adjust the throttle stop screw to give a satisfactory idle speed.

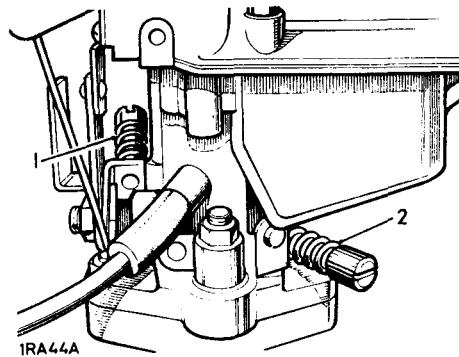
**Carburetter slow-running adjustment—6-cylinder models. (Basic Carburetter only)**

- 1 Run the engine until normal operating temperature is obtained. If necessary adjust slow-run screw to give the correct idling speed.
- 2 Lift the carburetter piston approximately 1 mm (0.031 in.)
- 3 If the engine speeds up immediately the mixture is too rich and the jet adjustment screw must be turned anti-clockwise, thus weakening the mixture; if the engine stops immediately, the mixture is too weak and the jet adjustment screw should be turned clockwise to enrich the mixture. If the engine just falters and then continues to run evenly the adjustment is correct.
- 4 Finally adjust the slow-run screw to get a smooth idling speed.
- 5 The fast idle screw should not require adjustment.
- 6 For starting at temperatures down to -18°C (0°F) push and turn the spring-loaded choke adjustment screw so that the peg is at right-angles to the slot as illustrated. Leave in this position.

When starting at temperatures below -18°C (0°F) turn the screw until peg is recessed in slot.

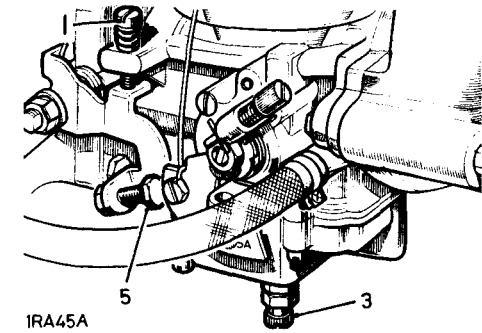

1RA45A

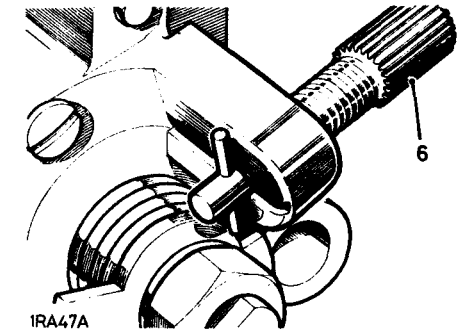

1RA47A

(7) Fuel sediment bowl—4-cylinder petrol models

The fuel sediment bowl, located on the right-hand side of the engine provides additional filtration between the pump and carburetter.

Clean as follows:

- 1 Remove the bowl by slackening the thumb screw and swinging the retainer to one side.
- 2 Remove and clean the filter gauze in clean petrol.
- 3 Ensure that the sealing washer is in good condition.
- 4 Replace gauze and refit the bowl.
- 5 Prime the pump by operating the hand lever.

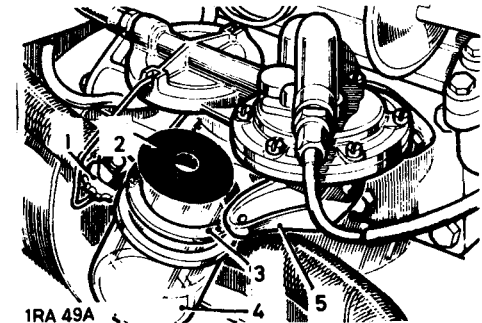

1RA49A

Fuel pump 6-cylinder petrol models—Clean filter

A single type electric fuel pump is fitted and is located above the right hand chassis member midway along the vehicle.

To remove the pump for filter cleaning, proceed as follows:

- 1 Disconnect the fuel pump feed lead at the snap connector.
- 2 Disconnect the fuel inlet pipe from the pump and block the end of the pipe by suitable means to prevent fuel draining from the tank.
- 3 Disconnect the outlet pipe.
- 4 Remove the two nuts securing the pump, earth braid and rubber mountings to the support bracket and remove the pump.

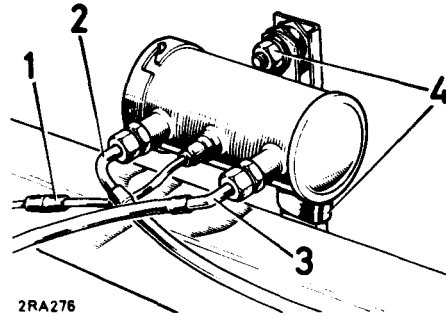

2RA276

Filter cleaning

- 5 Remove the inlet and outlet unions.
- 6 Release the end cover from the bayonet fixing.
- 7 Withdraw the filter and clean using a compressed air jet from the inside of the filter.
- 8 Remove the magnet from the end cover and clean. Replace the magnet in the centre of the end cover.
- 9 Reassemble the fuel pump and refit to the vehicle by reversing the removal procedure. Use a new gasket for the end cover if necessary. Ensure that the feed lead is reconnected and the earth braid fitted securely to the fixing points.

The inlet and outlet unions are at unequal distances from the feed lead. To ensure correct fuel pipe connections when refitting the pump, position the union nearest the feed lead connection towards the front of the vehicle.

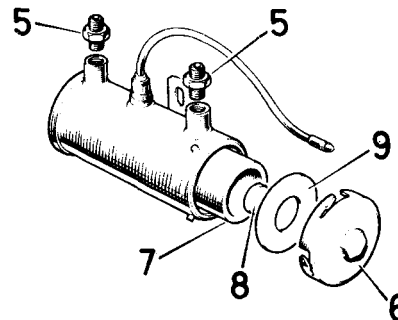

2RA277

(8) Tappet adjustment

The correct clearance is: 4-cylinder models, inlet and exhaust, 0,25 mm (0.010 in.) engine hot. 6-cylinder models, inlet 0,15 mm (0.006 in.) engine hot and exhaust 0,25 mm (0.010 in.) with the engine hot or cold.

To carry out tappet adjustment, proceed as follows:

- 1 Rotate the engine in the running direction until the valve receiving attention is fully open and then rotate the engine one complete turn, to bring the tappet on to the back of the cam.
- 2 Check the tappet clearance with a feeler gauge.
- 3 If adjustment is required, slacken the locknut.
- 4 Rotate the tappet adjusting screw until the clearance is correct; re-tighten the locknut, taking care to ensure that this operation does not upset the clearance.
- 5 Repeat for the other valves in turn.

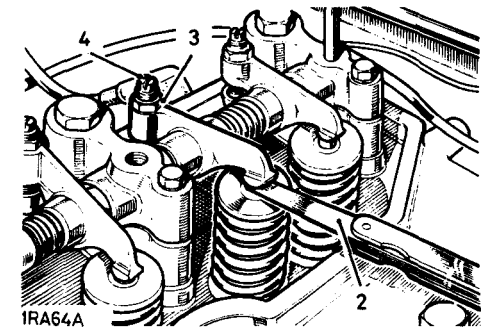

1RA64A

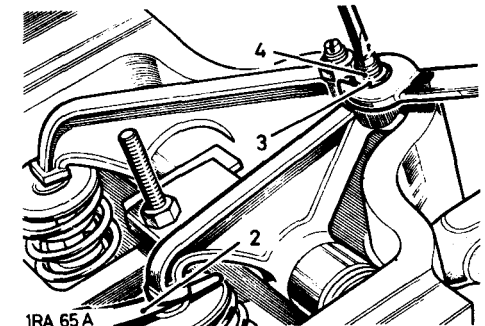

1RA 65 A

(9) Cooling system

Examine the cooling system for leaks and rectify as necessary. Renew hoses every 80,000 km (48,000 miles).

Frost precautions

In cold weather, when the temperature may drop to or below freezing point, precautions must be taken to prevent freezing of the water in the cooling system. As a thermostat is fitted in the system, it is possible for the radiator block to freeze in cold weather even though the engine running temperature is quite high; for this reason, the use of an anti-freezing mixture is essential.

Only anti-freeze solutions recommended in Section 09 should be used.

Land-Rovers leaving the factory have the cooling system filled with 50% mixture of anti-freeze and water. This gives protection down to -20°C to -36°C .

When the temperature is between 0°C and minus 18°C (32°F and 0°F), use one part of anti-freeze to two parts of water.

Proceed as follows:

- 1 Ensure that the cooling system is leak-proof; anti-freeze solutions are far more 'searching' at joints than water.
- 2 Drain and flush the system. Drain plug under radiator at right-hand side.

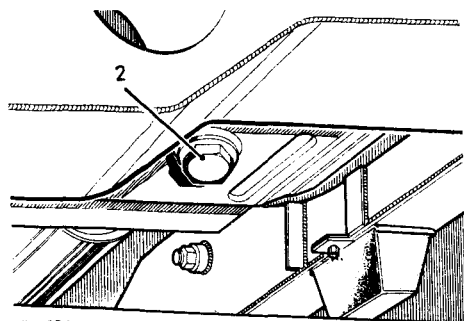

1RA69A

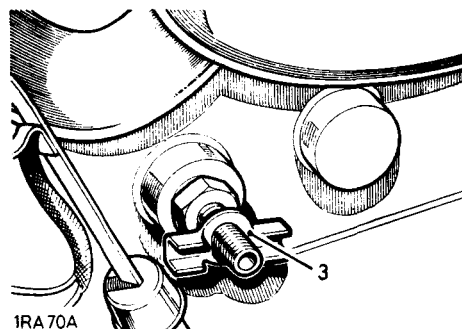

1RA70A

- 3 Drain tap or plug for cylinder block 4-cylinder at left-hand side of engine adjacent to dipstick. 6-cylinder at right-hand side of engine adjacent to engine breather.
- 4 Pour in approximately 4,5 litres (one gallon) of water, add solution, then top up with water to within 12 to 19 mm (0.5 to 0.75 in.) below bottom of filler neck.
- 5 Run the engine to ensure a good circulation of the mixture.

NOTE: When anti-freeze is not required the cooling system must be flushed out with clean water and refilled with a mixture one part Marston's SQ36 inhibitor to nine parts of water.

(10) Radiator water level

- 1 The radiator filler cap is under the bonnet panel.

Diesel models

- 2 Never run the engine without water, not even for a very brief period, otherwise the injectors may be seriously damaged. This is due to the very high rate of heat transfer in the region of the injector nozzles.

All models

- 3 The cooling system is pressurised and care must be taken when removing the radiator filler cap, especially when the engine is hot.
- 4 When removing the filler cap first turn it anti-clockwise to the stop and allow all pressure to escape, before pressing it down and turning further in the same direction to lift it off.
- 5 When replacing the filler cap, it is important that it is tightened down fully, not just to the first stop. Failure to tighten the filler cap properly may result in water loss, with possible damage to the engine through overheating.
- 6 All models have a semi-sealed cooling system, that is, an overflow bottle attached to the left-hand side of the radiator.
- 7 The water level in the cooling system is checked at the radiator only and topping-up is also carried out in the normal manner through the radiator filler. The pipe in the overflow bottle should always be submerged in water. With a cold engine the correct water level is 12 to 19 mm (0.5 to 0.75 in.) below the bottom of the filler neck. For capacities see Division 09. Use soft water wherever possible; if the local water supply is hard, rain-water should be used.
- 8

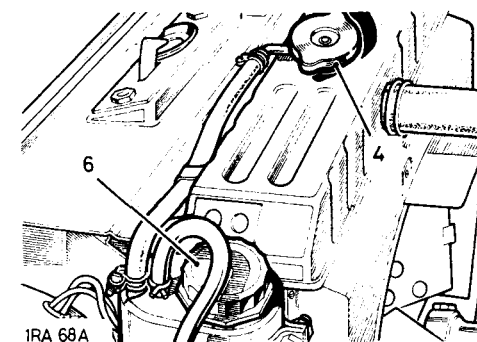

1RA68A

(11) Water level, windscreen washer as applicable

The windscreen washer reservoir (optional equipment in some counties), is located on the right-hand bulkhead.

- 1 Remove reservoir cap by turning anti-clockwise.
- 2 Top up reservoir to within approximately 25 mm (1 in.) below bottom of filler neck.
- 3 Use Clearalex windscreen washer powder in the bottle; this will remove mud, flies and road film.
- 4 In cold weather, to prevent freezing of the water, add 'Isopropyl Alcohol'. Do NOT use methylated spirits, which has a detrimental effect on the screen-washer impeller.

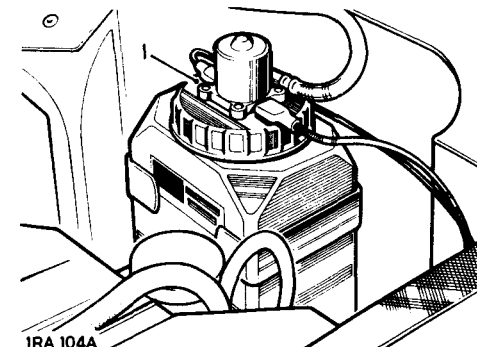

1RA104A

(12) Fan belt adjustment

4 cylinder models:

- 1 Check by thumb pressure between the fan and crankshaft pulleys. Movement should be 6,3 to 9,5 mm (0.25 to 0.375 in.)

If necessary adjust as follows:

- 2 Slacken the pivot bolt securing the alternator to the mounting bracket.
- 3 Slacken the adjusting bolt.
- 4 Pivot the alternator inwards or outwards as necessary and adjust until the correct belt tension is obtained.
- 5 Tighten adjusting and pivot bolts.

6-cylinder models:

- 6 Check by thumb pressure between the fan and crankshaft pulleys. Movement should be 8 to 11 mm (0.312 to 0.437 in.) Adjust as above.

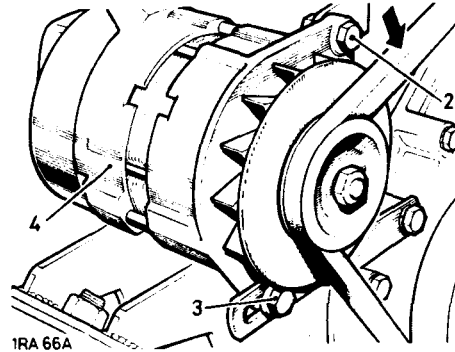

Air pump drive belt adjustment, 6-cylinder models

- 1 Check by thumb pressure midway between the air pump and water pump pulleys. Movement should be 6,3 mm (0.25 in.). If necessary, adjust as follows:
- 2 Slacken the pivot bolts securing the air pump to the top mounting bracket.
- 3 Slacken the nut and bolt securing the air pump to the adjustment bracket.
- 4 Pivot the air pump as necessary and adjust until the correct belt tension is obtained.
- 5 Tighten the adjusting and pivot bolts and nuts.

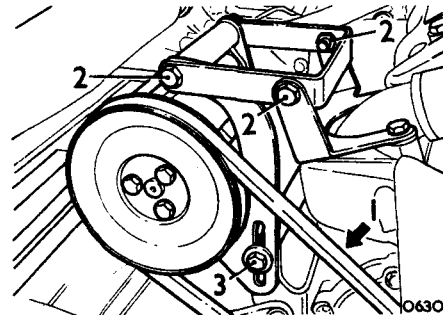

(13) Accelerator linkage—all Models

- 1 Lubricate the accelerator linkage using clean engine oil paying particular attention to accelerator cross craft brackets, bell crank bushes and ball joint sockets on the control rods.
- 2 Check the linkage for correct operation and ensure that there is no tendency to stick. Badly worn parts should be replaced as soon as possible.

(14) Engine mountings

Check security of engine mountings; rectify as necessary.

Engine sump bolts, see operation 12.60.44.

(15) Engine breather filters—all Models

Clean as follows:

- 1 Remove the filters.
- 2 Wash the gauze thoroughly by swilling the units in petrol.
- 3 Re-wet the gauzes by dipping in clean engine oil and shake off the surplus; 4-cylinder models, replace the engine breather filter with the slot facing forward and the oil filler filter with the slot facing the rear of the vehicle.
- 4 Models with sealed engine breather system. Connect hose to top breather.

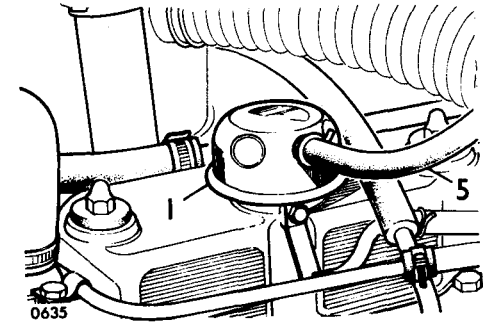

(16) Crankcase emission control, flame-trap type (as applicable)

Replace as follows:

- 1 Detach the rubber hoses from each side of the flame trap by compressing the clips.
- 2 Withdraw flame trap.
- 3 Fit new flame trap by reversing removal procedure.
- 4 Warm up engine and re-adjust carburetter if necessary.

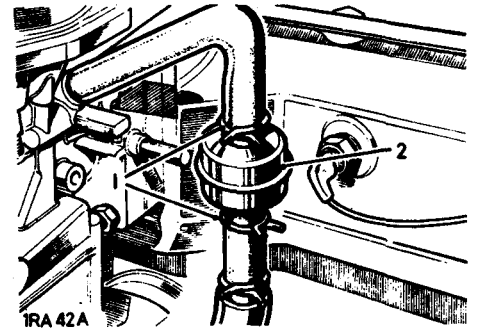

(17) Fuel filter, paper element type—Diesel models

Drain off water as follows:

- 1 Slacken off drain plug to allow water to run out.
- 2 When pure diesel fuel is emitted, tighten drain plug.

Change filter element as follows: In some instances it may be advantageous to remove the complete unit before attempting to change the filter element.

- 3 Support element holder.
- 4 Unscrew the special bolt on the top of the filter, the element holder can now be removed.
- 5 Remove and discard the used element.
- 6 Wash the element holder in petrol or fuel oil.
- 7 If necessary renew both the large rubber washer and the small rubber washer in the filter top, also renew the large rubber washer in the element holder.
- 8 Push the new element on to the filter top spigot with the perforated holes in the element to the top.
- 9 Fit the element holder to the bottom of the element, and secure with the special bolt.
- 10 Prime the system and check for fuel leaks.

Fuel filter element, 6-cylinder models

The fuel filter element, located on the dash at the right-hand side of the engine compartment, provides additional filtration between pump and carburetter.

Replace element as follows:

- 1 Support element holder.
- 2 Unscrew the special bolt at bottom of filter. The element holder can now be removed.
- 3 Remove and discard the used element.
- 4 Thoroughly clean the element holder in petrol.
- 5 If necessary renew the upper and lower centre seals and also the seal for the centre bolt.
- 6 Fit the new element, large hole uppermost into the holder using the seal supplied with the element.
- 7 Place the element holder in position and secure with the special bolt.
- 8 Start the engine and check for fuel leaks.

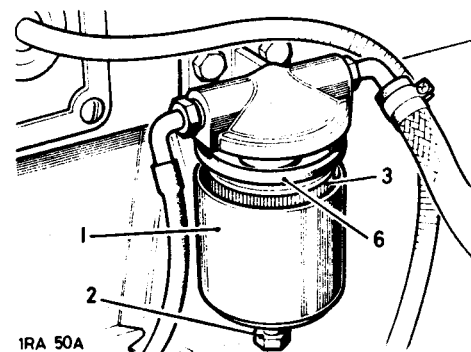
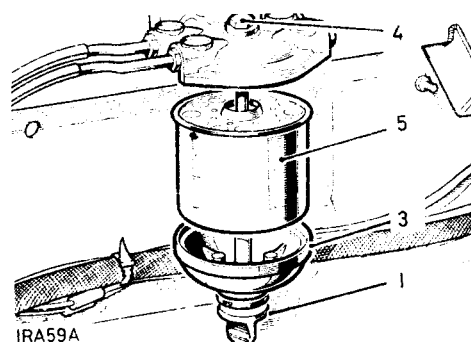
**(18) Fuel sedimenter—Diesel models**

The sedimenter increases the working life of the fuel filter by removing the larger droplets of water and larger particles of foreign matter from the fuel.

Drain off water as follows:

- 1 Slacken off drain plug to allow water to run out.
- 2 When pure diesel fuel is emitted, tighten drain plug. Dismantle and clean as detailed below.
- 3 Disconnect fuel inlet pipe at sedimenter and raise pipe above level of fuel tank to prevent draining from tank. Support in this position.
- 4 Support sedimenter bowl and unscrew bolt on top of unit.
- 5 The lower bowl and element can now be removed.
- 6 Clean all parts in petrol.
- 7 Fit new oil seals and reverse removal procedure.
- 8 Slacken off the drain plug, when pure diesel fuel runs out tighten plug. Start engine and check for air leaks.

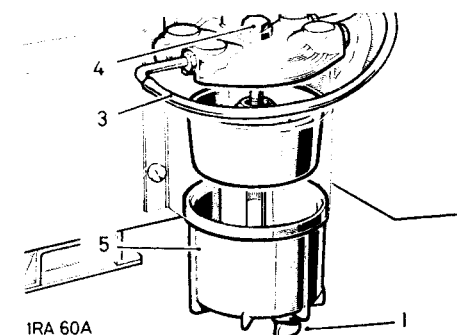
**(19) Air injection system—6-cylinder models models**

The air pump driven by the engine, delivers air to the exhaust valves via the air rail. A check valve prevents damage to the pump should backfire or belt breakage occur. A relief valve, located in the air pump, is required to dump part of the air at high speeds to prevent pump damage.

(20) Air cleaner—all Models

Attention to the air cleaner is extremely important, especially under dusty conditions, as engine wear generally will be seriously affected if the vehicle is run with an excessive amount of sludge in the cleaner oil bath.

In cases where the vehicle is operated under dusty road or field conditions, attention must be more frequent, even to the extent of a daily oil change; under extremely bad conditions, cleaning twice daily may be called for.

Proceed as follows:

- 1 Slacken wing nut and release the clamping strap securing the complete air cleaner.
- 2 Disconnect the outlet elbow from the carburettor intake pipe and remove the cleaner from the vehicle.
- 3 Remove the oil bowl from the bottom of the cleaner by releasing the three securing clips.
- 4 Clean all dirty oil and sludge from the bowl and refill with fresh engine oil to the level indicated by a ring formed in the pressing; the capacity is approximately 0,85 litre (1.5 Imperial pints).
- 5 Clean the filter in the cleaner body by swilling the complete body in petrol or paraffin and shake off the surplus.
- 6 Replace the bowl and refit the complete unit in the vehicle.

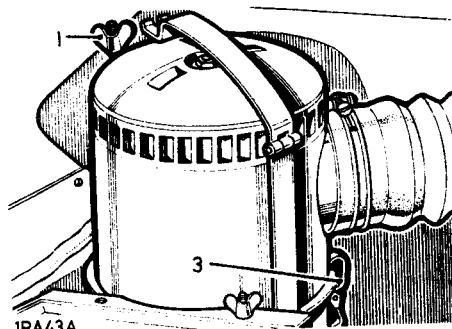

(22) Check injectors for burst pressure, and spray

NOTE: Absolute cleanliness is essential when handling any component of the fuel injection system.

The use of a test pump is essential when servicing injectors; it is recommended therefore, that servicing of injectors is carried out by a Rover Distributor or Dealer or CAV Agent. **WARNING:** Great care should be taken to prevent the hands getting into contact with the spray, as the working pressure will cause the fuel to penetrate the skin with ease.

IGNITION

(23) & (24) Sparking plugs—Petrol models

- 1 The sparking plugs are fitted with plastic covers.
- 2 To gain access to the plugs for cleaning and gap-setting, pull up the plug covers without detaching them from the high tension leads.
- 3 Check or replace the sparking plugs as applicable. If the plugs are in good condition, they should be cleaned, preferably using an approved spark plug cleaning machine.
- 4 Test the plugs in accordance with the plug cleaning machine manufacturer's recommendations.
- 5 If satisfactory set the electrode gap to 0,75 to 0,80 mm (0.029 to 0.032 in.) and replace.

It is important that only the recommended sparking plugs are used for replacements:

- 4-cylinder models 8,0:1, use Champion UN12Y
- 4-cylinder models 7,0:1 (optional), use Champion N8
- 6-cylinder models, use Champion N5

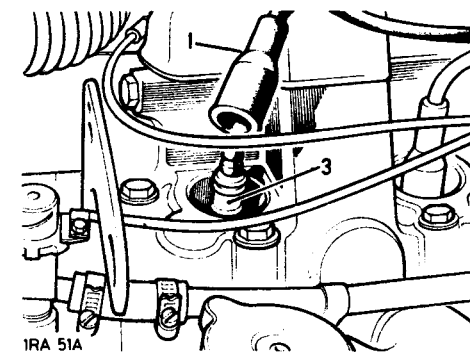

(21) Flywheel housing drain plug

- 1 The flywheel housing can be completely sealed to exclude mud and water under severe wading conditions, by means of a plug fitted in the bottom of the housing.
- 2 The plug is screwed into a hole adjacent to the drain hole and should only be fitted when the vehicle is expected to do wading or very muddy work.
- 3 When the plug is in use it must be removed periodically and all oil allowed to drain off before the plug is replaced.

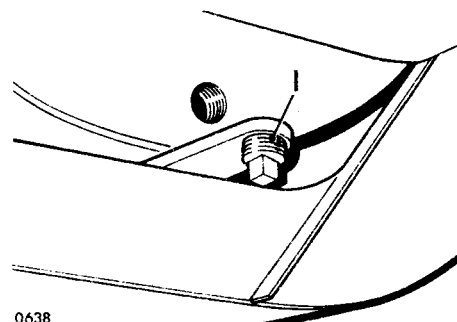

(25) Distributor contact points

Check and adjust the contact points clearance as follows. (4-cylinder distributor illustrated).

- 1 Remove the distributor cap and rotor arm; then turn the engine, using the starting handle, until the contacts are fully open.
- 2 The clearance should be 0,35 to 0,40 mm (0.014 to 0.016 in.) with the feeler gauge a sliding fit between the contacts.
- 3 If necessary, slacken the screw which secures the adjustable contact.
- 4 Adjust by the adjuster slot until the clearance is correct; re-tighten the retaining screw.
- 5 Replace the rotor arm and distributor cap.

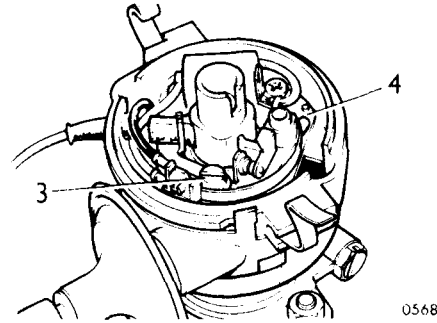
**(26) Distributor maintenance**

Lubricate as follows:

- 1 Remove the distributor cap and rotor arm.
- 2 Lightly smear the cam with clean engine oil.
- 3 Add a few drops of thin machine oil to lubricate the cam bearing and distributor shaft.
- 4 Add a few drops of thin machine oil through the side of the contact breaker base plate, to lubricate the automatic timing control.
- 5 Removing the plastic clip (4-cylinder models) or the nut (6-cylinder models) on the terminal block and lift off the spring and moving contact, also remove adjustable contact secured with a screw. Ensure that the contacts are free from grease or oil; if they are burned or blackened, clean with a fine carborundum stone and wipe with a petrol-moistened cloth.
- 6 Add a smear of grease to contact pivot before replacing the contacts. Then adjust as detailed in previous operation.
- 7 Wipe the inside and outside of the cap with a soft dry cloth; ensure that the small carbon brush works freely in its holder.
- 8 Replace rotor arm and distributor cap.

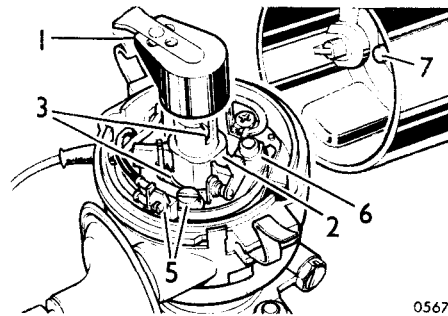
**High tension leads**

- 1 A careful examination should be carried out on all high tension leads including the coil to distributor lead.
- 2 Look for any signs of corrosion, insulation cracking or deterioration, particularly of the end contacts. Renew any faulty leads.

(27) Ignition timing—Petrol models

- 1 Should the distributor have been disturbed, the ignition timing must be reset as follows:
- 2 Set the contact breaker point gap to 0,35 to 0,40 mm (0.014 to 0.016 in.) with the points fully open.

2¼ litre Petrol models

- 3 The timing pointer represents 6° B.T.D.C., 3° B.T.D.C. and T.D.C. respectively.

- 4 Rotate the engine until the mark on the crankshaft pulley is in line with the pointer as follows:

Note that three types of timing marks are in use, either a multiple pointer with a single mark on the pulley or single pointer with a scale of marks on the pulley.

The multiple pointers represent 6° B.T.D.C., 3° B.T.D.C., T.D.C. and 6° A.T.D.C. respectively.

The scale on the pulley represents 6° B.T.D.C., 3° B.T.D.C., T.D.C., 3° A.T.D.C. and 6° A.T.D.C.

See page 86—19 for an alternative timing mark and pointer.

8.0 : 1 compression ratio

T.D.C. when using 90 octane fuel

3° A.T.D.C.* when using 85 octane fuel

7.0 : 1 compression ratio (optional)

3° B.T.D.C. when using 83 octane fuel

T.D.C. when using 75 octane fuel

* Estimate this position on pulley on 3-point pointer.

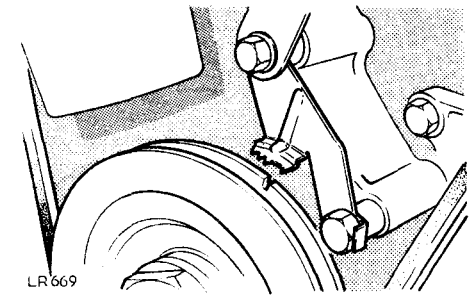
**2.6 litre 6-cylinder models**

- 5 Rotate the engine until the appropriate mark on the crankshaft pulley is in line with the pointer as follows:

7.8 : 1 compression ratio

2° A.T.D.C. when using 90 octane fuel

7.0 : 1 compression ratio (optional)

2° B.T.D.C. when using 83 octane fuel

T.D.C. when using 80 octane fuel

2° A.T.D.C. when using 78 octane fuel

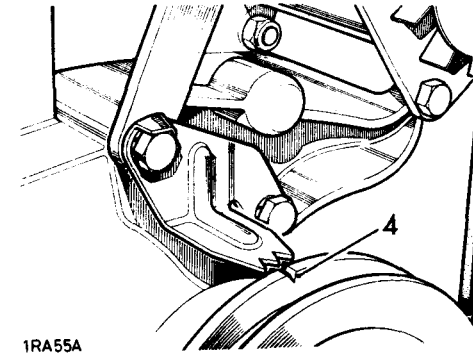

- 6 The distributor rotor will now correspond with No. 1 cylinder high tension lead terminal.

- 7 Slacken the pinch bolt at the base of the distributor head, rotate the distributor bodily in the opposite direction to the arrow on the side of the distributor (4 cylinder models) or on the rotor arm (6-cylinder models) until the contact breaker points are just opening with the fibre cam follower on the leading side of the cam; re-tighten the pinch bolt.

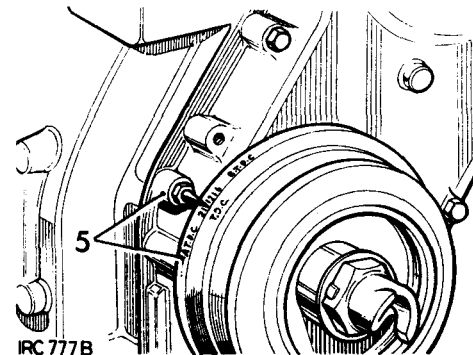

TRANSMISSION

(28) Check for oil leaks; rectify as necessary

(29) Clutch fluid reservoir

- 1 Check fluid level in reservoir by removing cap.
- 2 Top up if necessary to bottom of filler neck.

Use Castrol Girling Brake and Clutch Fluid 'Crimson' (Specification J. 1703).

If significant topping-up is required, check for leaks at master cylinder, slave cylinder and connecting pipe.

(30) Check tightness of all propeller shaft coupling bolts

(31) Propeller shaft lubrication

- 1 Apply one of the recommended greases at the lubrication nipple on the sliding portion of the rear propeller shaft.
- 2 To the lubrication nipples fitted to the universal joints of both front and rear shafts.

Front propeller shaft sliding portion

Lubricate the sliding spline on the front propeller shaft, with one of the recommended greases, as follows:

- 1 Disconnect one end of the propeller shaft.
- 2 Remove plug in sliding spline and fit a suitable grease nipple.
- 3 **Important.** Compress propeller shaft at sliding joint to avoid overfilling, then apply grease.
- 4 Replace grease nipple with plug and reconnect propeller shaft.

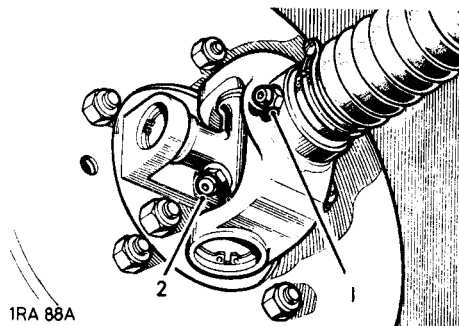
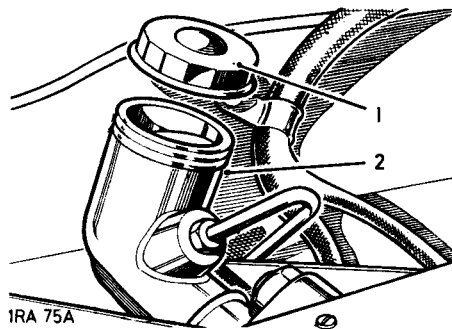

(32) Main gearbox oil level

Check oil level daily or weekly when operating under severe wading conditions.

- 1 The main gearbox and clutch withdrawal mechanism are lubricated as one unit. Check oil level and top up if necessary to the bottom of the filler-level plug hole.
- 2 If significant topping up is required check for oil leaks at drain and filler plugs, all joint faces and through drain hole in bell housing.

(33) Transfer box oil level

Check oil level daily or weekly when operating under severe wading conditions.

- 1 The transfer box and front wheel drive housing are lubricated as one unit.
- 2 Check oil level and top up if necessary to the bottom of the filler-level plug hole. The filler-level plug is in the rear face of the transfer box.
- 3 If significant topping up is required check for oil leaks at drain and filler plugs, all joint faces and through drain hole in bell housing.

(34) Front differential oil level

- 1 Check oil level and top up if necessary to the bottom of the filler plug hole located at the front of the axle casing. A second plug fitted at the rear of the axle casing can be disregarded.
- 2 If significant topping up is required check for oil leaks at plugs, joint faces and oil seals adjacent to axle shaft flanges and propeller shaft driving flange.

(35) Rear differential oil level

- 1 Check oil level and top up if necessary to the bottom of the filler plug hole.
- 2 If significant topping up is required check for oil leaks at plugs, joint faces and oil seals adjacent to axle shaft flanges and propeller shaft driving flange.

(36) Check hydraulic clutch pipes and hoses visually for cracks, leaks and chafing

(37) Axle case breathers

- 1 Clean exterior of breathers.
- 2 Unscrew breathers from their tapered threads in axle and wash in petrol.
- 3 Shake breather to ensure ball valve is free.
- 4 Lubricate balls with engine oil.

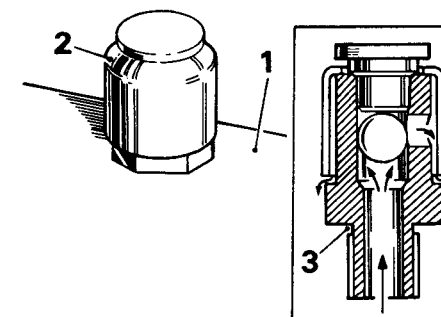
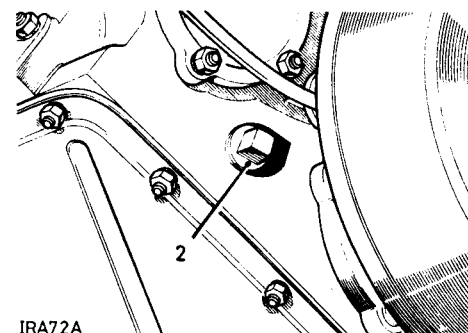
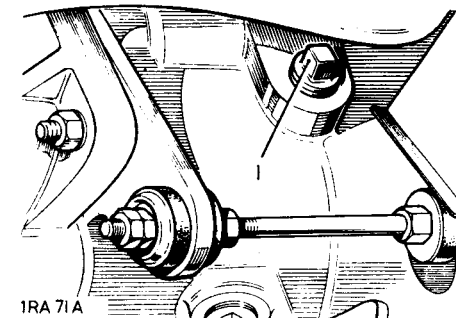

STEERING AND SUSPENSION

(38) Steering ball joints

- 1 Check rubber boots daily when operating under arduous conditions.
- 2 The steering joints have been designed to retain the initial filling of grease for the normal life of the ball joints; however, this applies only if the rubber boot remains in the correct position. Check to ensure that the rubber boots have not become dislodged or damaged, and check for wear in the joint.
- 3 This can be done by moving the ball joint vigorously up and down. Should there be any appreciable free movement the complete joint must be replaced.

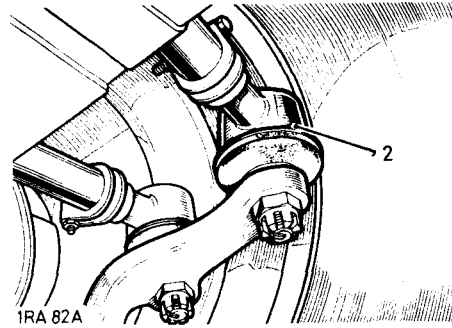

(39) Suspension fixings—Check security of all suspension fixings, rectify as necessary

(40) Wheel alignment

Special equipment is required to check wheel alignment and this work should be carried out by a Rover Distributor or Dealer.

For those owners who have suitable equipment, the alignment should be 1,2 to 2,4 mm (0.046 to 0.093 in.) toe-in.

To adjust

- 1 Set the vehicle on level ground with the road wheels in the straight ahead position and push it forward a short distance.
- 2 Slacken the clamps securing the ball joints at each end of the track rod.
- 3 Turn the track rod to decrease or increase its effective length as necessary until the toe-in is correct.
- 4 Push the vehicle rearwards turning the steering wheel from side to side to settle the ball joints, then with the road wheels in the straight ahead position, push the vehicle forward a short distance.
- 5 Recheck the toe-in, if necessary carry out further adjustment.

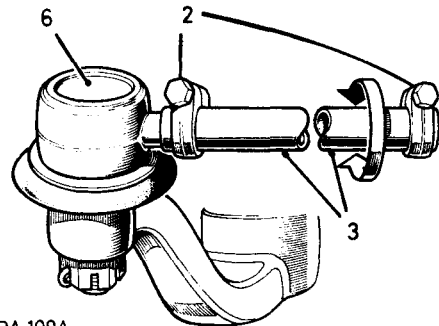

- 6 When the toe-in is correct, lightly tap the track rod ball joints towards the rear of the vehicle to the maximum of their travel. This ensures full unrestricted movement of the track rod. Then secure the ball joint clamps.

(41) Check steering for oil leaks—investigate and rectify as necessary

(42) Check shock absorbers for leaks and rectify as necessary

(43) Steering relay unit

Check oil level and top-up if necessary until the oil is visible at the base of the filler and breather holes. If significant topping-up is required, check joints for leakage and fit new joint washers as necessary. To check oil level and top up, proceed as follows:

- 1 Remove the fixings and withdraw radiator grille.
- 2 Remove two of the bolts securing the relay top cover.
- 3 Using one of the holes as an oil filler (the other acting as a breather hole) fill the relay unit with the correct grade of lubricating oil to the bottom of the filler hole.
- 4 Whilst filling, it is probable that oil will eject through the breather hole. If this occurs do not assume that the relay unit is full. Time must be given to allow the oil to find its way to the main chamber. Wait a few moments until the breather hole is clear of oil, then continue filling.
- 5 As the unit fills up, air is forced out usually in the form of an oil bubble, escaping through the breather hole, again giving the impression that the unit is full. Wait for the bubble to subside, then continue filling in this manner until the oil is clearly visible at the base of the filler and breather holes.
- 6 Replace the two top cover bolts. Refit the radiator grille and name plate.

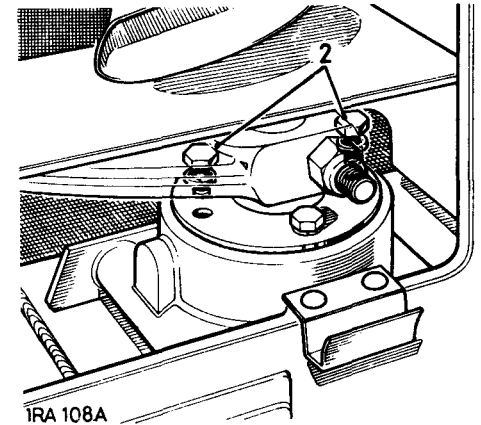
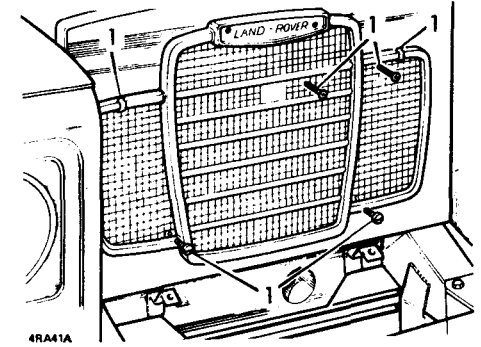

(44) Steering box oil level

- 1 Check oil level and top up if necessary to the bottom of the filler-plug hole on the top of the cover plate. Access to the plug is gained by lifting the bonnet panel.
- 2 If significant topping up is required check for oil leaks at joint faces and rocker shaft oil seal.

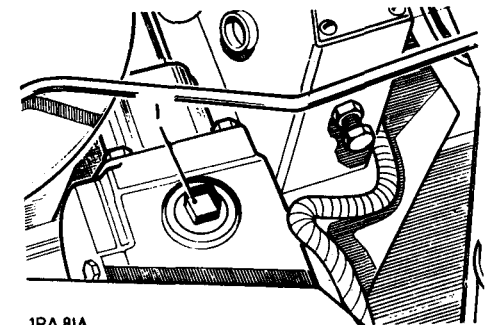

(45) Steering box

Check steering box mountings for security and steering box for backlash. Rectify as necessary.

(46) Swivel pin housing oil level

- 1 The front wheel drive universal joints, swivel pins and front hubs receive their lubrication from the swivel pin housings. Check oil level and top up if necessary to the bottom of the filler-level plug holes at the rear of the housings.
- 2 If significant topping up is required check for oil leaks at plugs, joint faces and oil seals.

BRAKES

(47) Check visually hydraulic pipes and unions for chafing, leaks and corrosion—rectify as necessary

(48) Brake fluid reservoir

- 1 Check fluid level in brake reservoir by removing cap.
- 2 Top up if necessary to level mark on reservoir.

Use Castrol Girling Brake and Clutch Fluid 'Crimson' (Specification J. 1703).

If significant topping-up is required, check master cylinder, wheel cylinders and brake pipes for leakage; any leakage must be rectified immediately.

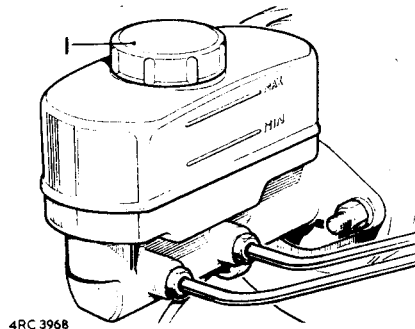

(49) Transmission brake adjustment

If hand brake movement is excessive, adjust as follows:

- 1 Release the hand brake. The adjuster protrudes from the front of the brake backplate.
- 2 During rotation of the adjuster a click will be felt and heard at each quarter revolution. Rotate adjuster in a clockwise direction until the brake shoes contact the drum. Then unscrew the adjuster two clicks and give the hand brake a firm application to centralise the shoes.

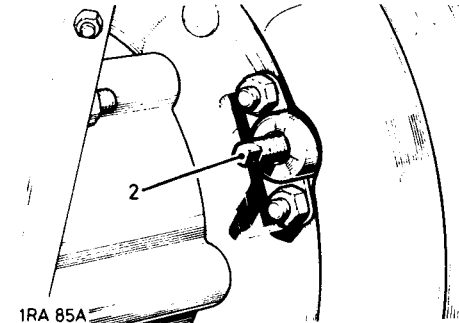

(50) Foot and hand brake

- 1 Check operation of foot and hand brake, ensure that the brake pedal travel is not excessive and maintains a satisfactory pressure under normal working load.
- 2 Excessive pedal travel indicates worn brake linings or the necessity for adjustment.
- 3 If the brakes feel spongy this may be caused by air in the hydraulic system and must be removed by bleeding the system at each wheel cylinder.
- 4 Prior to this operation, all hydraulic hoses, pipes and connections should be checked for leaks and any leaks rectified.
- 5 Check operation of hand brake and ensure that it holds the vehicle satisfactorily.

Wheel brake adjustment

When the vehicle is used in deep muddy conditions the brake drums must be periodically removed and cleaned, at the same time the brake shoes and anchor plate should be thoroughly cleaned.

When used continuously under exceptionally wet and muddy conditions this operation may be advisable once, or even twice a week, to prevent the abrasive action of packed mud rapidly wearing out brake linings and drums.

When lining wear has reached the point where the pedal travel becomes excessive, it is necessary to adjust the brake shoes in closer relation to the drum.

Proceed as follows:

88 Models

- 1 Jack up each wheel in turn.
- 2 On the back face of the brake anchor plate will be found a hexagon adjustment bolt which operates a snail cam bearing on the leading shoe. Only one of these is fitted to each wheel brake unit, thereby providing single-point adjustment.

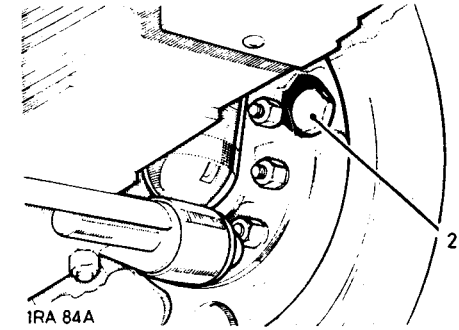

- 3 Spin the wheel and rotate the adjuster bolt until the brake shoe contacts the drum, then ease the adjuster until the wheel again rotates freely.
- 4 Repeat for the other three wheels.

109 Models

- 5 Each shoe is independently set by means of a hexagon adjustment bolt operating through a serrated snail cam.
- 6 Apply the brakes and set the snail cam adjusters so that the brake shoes are in firm contact with the drums.
- 7 Slacken off each adjuster just sufficiently for the drum to rotate freely.
- 8 Repeat for the other wheels in turn.

NOTE: The rear brake shoes should be adjusted individually to obtain the best results.

(51) Inspect brake linings for wear, drums for condition, replace worn parts as necessary

(52) Handbrake linkage

The hand brake operates a mechanical brake unit mounted on the output shaft from the transfer box.

Lubricate the hand brake linkage and check for worn parts. Take care not to contaminate the hand brake linings with oil.

(53) Servo hose(s) — check hose(s) for security and condition, replace as necessary

ELECTRICAL

(54) Electrical and interior equipment

6 Check operation of all lamps, direction indicators, warning lights, horn, instruments and other equipment.

(55) Battery acid level

Check weekly when operating under severe conditions. The battery is located under the bonnet at the front right-hand side.

The specific gravity of the electrolyte should be checked at every maintenance inspection. Readings should be:
Temperate climate below 26.5°C (80°F) as commissioned for service, fully charged 1.270 to 1.290 specific gravity.

As expected during normal service, three-quarter charged 1.230 to 1.250 specific gravity.

If the specific gravity should read between 1.190 to 1.210, half-charged, the battery must be bench charged and the electrical equipment in the car should be checked.

Tropical climate above 26.5°C (80°F) as commissioned for service, fully charged 1.210 to 1.230 specific gravity.

As expected during normal service, three-quarter charge 1.170 to 1.190 specific gravity.

If the specific gravity should read between 1.130 to 1.150, half-charged, the battery must be bench charged and the electrical equipment on the car should be checked.

Check acid level as follows:

1 Wipe all dirt and moisture from the battery top.

- 2 Remove the filler plugs or manifold lid. If necessary add sufficient distilled water to raise the level to the top of separators. Replace the filler plugs or manifold lid.
- 3 Avoid the use of a naked light when examining the cells.
- 4 In hot climates it will be necessary to top up the battery at more frequent intervals.
- 5 In very cold weather it is essential that the vehicle is used immediately after topping up, to ensure that the distilled water is thoroughly mixed with the electrolyte. Neglect of this precaution may result in the distilled water freezing and causing damage to the battery.

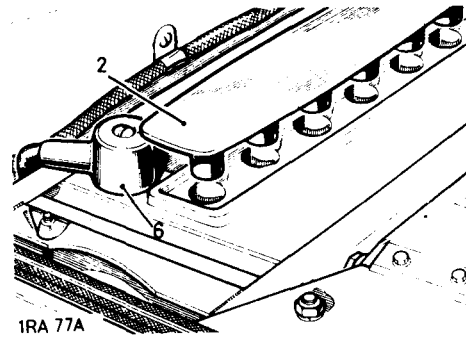

1RA 77A

(56) Battery terminals

- 6 Remove battery terminals, clean, grease and refit.
- 7 Replace terminal screw; do not over-tighten. Do not use the screw for pulling down the terminal.
- 8 Do NOT disconnect the battery cables while the engine is running or damage to alternator semiconductor devices may occur. It is also inadvisable to break or make any connection in the alternator charging and control circuits while the engine is running.
- 9 It is essential to observe the polarity of connections to the battery, alternator and regulator, as any incorrect connections made when reconnecting cables may cause irreparable damage to the semiconductor devices.

(57) Headlamp beam setting

- 1 This operation requires special equipment and should be carried out by a Rover Distributor or Dealer.
- 2 In an emergency each headlamp can be adjusted by means of a headlamp horizontal adjusting screw.
- 3 The headlamp vertical adjusting screw. The adjusting screws are accessible through slots in the headlamp bezel.

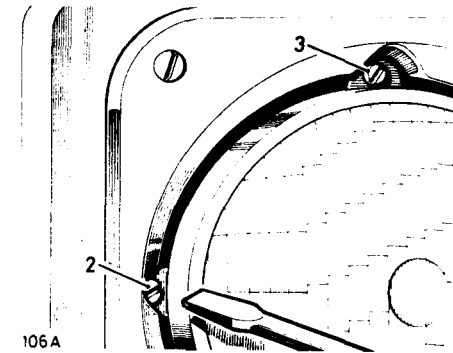

106A

(58) Windscreen wiper blades

Examine condition of wiper blades, replace as necessary:

- 1 Pull wiper arm forward.
- 2 Lift spring clip and withdraw blade from wiper arm.
- 3 To fit new blade reverse removal procedure.

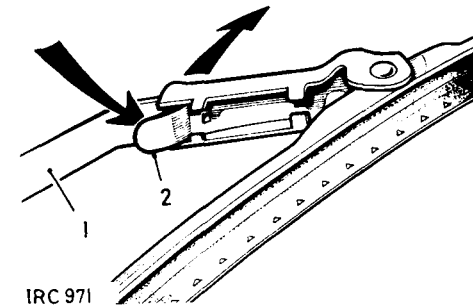

IRC 971

EXHAUST AND FUEL PIPES

(59) & (60) Exhaust system, fuel, clutch and brake pipes

- 1 Check exhaust system fixings for security, paying particular attention to heat shields, flexible mounting plates and clamps.
- 2 Examine the system for signs of leakage and blowing. Any silencers or pipes found to be leaking or badly corroded should be replaced:
- 3 At the same time check all fuel, clutch and brake pipes, unions and hoses for signs of leakage, corrosion, chafing or damage.

WHEELS AND TYRES

(61) Check that tyres comply with manufacturer's specification

(62) Tyre pressures

Maximum tyre life and performance will only be obtained if the tyres are maintained at the correct pressures.

(63) & (65)

- 1 Whenever possible check with the tyres cold as the pressure is about 0,1 kg/cm² (2 lb/sq. in.) 0,14 bars higher at running temperature.
- 2 Always replace the valve caps as they form a positive seal on the valves.
- 3 Any unusual pressure loss in excess of 0,05 to 0,20 kg/cm² (1 to 3 lb/sq. in.) 0,07 to 0,21 bars per week should be investigated and corrected.
- 4 Always check the spare wheel so that it is ready for use at any time.
- 5 At the same time remove embedded flints etc. from the tyre treads with the aid of a penknife or similar tool and check that the tyres have no breaks in the fabric or cuts to sidewalls etc. Clean off any oil or grease on the tyres using white spirit sparingly.
- 6 Check that there are no lumps or bulges in the tyres or exposure of the ply or cord structure.
- 7 'Butyl' synthetic inertubes are fitted and all repairs must be vulcanised.
- 8 It is an offence to run tyres when the tread pattern of the tyre does not have a depth of at least 1 mm throughout at least three-quarters of the breadth of the tread and round the entire outer circumference of the tyre.
- 9 It is advisable to run-in new tyres by driving at reasonable speeds for the first 400 km (250 miles) or so before driving at higher speeds.

(64) Road wheel nuts

Check road wheel nuts, tighten as necessary.

(66) Changing wheel positions

The road wheels should be changed round as illustrated to equalise tyre wear. When cross-country tyres are used, the 'V' tread should be directed to the front at the top.

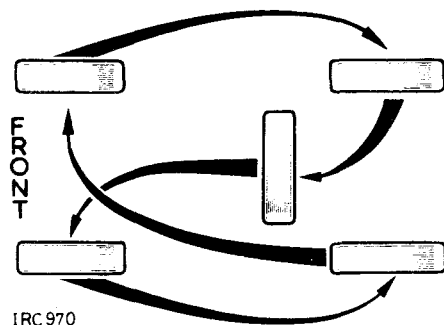

WARNING: Do not touch the outer ring of nuts on divided type wheels (optional equipment) unless the wheel is removed and the tyre fully deflated, or severe personal injury may result.

IMPORTANT: As the Land Rover is fitted with a transmission brake, it is necessary before removing a road wheel to apply the hand brake and engage four-wheel drive. This will ensure that the hand brake is operative on all four wheels. Remember to engage two-wheel drive when the road wheel has been replaced.

BODY

(67) (70) & (71) Door locks and mechanisms

- 9 Check operation of all door locks and mechanisms, window controls, safety catches, bonnet catch etc.; apply a few spots of oil as necessary.

(68) (69) & (72) Seats, safety belts and rear view mirrors

- 7 Check all seat fixings for security and examine condition of safety harness. Safety harness which have been used in an accident or are frayed or cut, must be replaced.
- 8 Check rear view mirror(s) for security and examine mirror face for signs of cracks or crazing.

(73) Check cleanliness of controls, door handles and steering wheel

GENERAL

(74) Road or roller test

Give the vehicle a roller or road test and carry out any further adjustments required including brakes, clutch, throttle linkage etc. Check steering and all gears in high and low range including the high range four-wheel drive control. Check operation of all lights and instruments. After test check for oil, fuel and fluid leaks at all plugs, flanges, joints and unions.

PREVENTIVE MAINTENANCE

In addition to the recommended periodical inspection of brake components it is advisable as the vehicle ages, and as a precaution against the effects of wear and deterioration, to make a more searching inspection and renew parts as necessary.

It is recommended that:

Brake linings, hoses and pipes should be examined at intervals no greater than those laid down in the Maintenance Summary.

Rubber seals in brake system—Every 60 000 km (36,000 miles) or 36 months. Renew all rubber seals in master cylinder, wheel cylinders and servo until where applicable. This should be done every three years if mileage travelled is less than 60 000 km (36,000 miles). Refill with correct fluid.

Fluid changing, brake system—Every 30 000 km (18,000 miles) or 18 months. All brake fluid absorbs moisture from the air and as a result its boiling point is lowered with a consequent deterioration in performance. In a sealed brake system, water absorption takes place over a period and can, if not remedied reduce brake performance to a dangerous level. All the fluid in the brake system should be changed every 30 000 km (18,000 miles) or 18 months. It should also be changed before touring in mountainous areas, if not done in the previous nine months. Use only fluid recommended in Section 09.

Care must be taken always to observe the following points:

- a At all times use the recommended brake fluid.
- b Never leave fluid in unsealed containers. It absorbs moisture quickly and can be dangerous if used in your braking system in this condition.

- c Fluid drained from the system or used for bleeding is best discarded.
 - d The necessity for absolute cleanliness throughout cannot be over-emphasized.
- 4 Hold the tube under the fluid surface and, with the foot brake fully depressed, tighten the bleed screw. Do not overtighten.
 - 5 Repeat for the other three wheels in turn, finishing at the one nearest the brake pedal.
 - 6 Pump brake pedal until rear shoes are in firm contact with the brake drums.
 - 7 While holding pedal depressed, adjust rear adjuster up to the shoes.
 - 8 Release pedal and slacken rear adjusters until shoes are just clear of the drums.
 - 9 Adjust front shoes in the normal manner.

Replacing Brake-Shoes

When it becomes necessary to renew the brake shoes, it is essential that only genuine shoes, with the correct grade of lining are used. Always fit new shoes as complete axle sets, never individually or as a single wheel set. Serious consequences could result from out-of-balance braking due to mixing of linings.

Bleeding the brake system

When the fluid in the hydraulic system has been changed or any components replaced it will be necessary to remove the air by bleeding the hydraulic system at each wheel cylinder. Bleeding must always be carried out at all wheels.

Proceed as follows:

- 1 Slacken the adjusters off on all brake shoes.
- 2 Attach a length of rubber tubing to the bleed screw on the wheel cylinder furthest from the brake pedal and place the lower end of the tube in a glass jar containing brake fluid.
- 3 Slacken the bleed screw and depress the brake pedal and release slowly. Pause at each end of the return stroke to allow the master cylinder to recuperate. Continue pumping in this manner until the fluid issuing from the tube shows no signs of air bubbles when the tube is held below the surface of the fluid in the jar.

The fluid in the reservoir should be replenished throughout the operation.

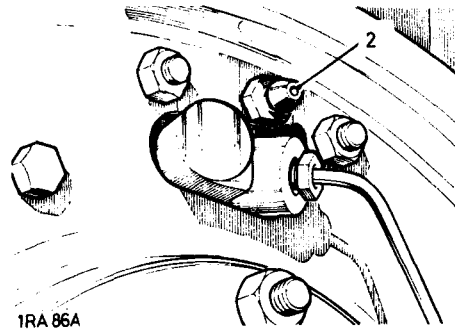

SPECIAL OPERATING CONDITIONS

When the vehicle is operated on dusty, wet or muddy terrain, more frequent attention, depending on the conditions, should be paid to the following:

Daily or Weekly

Check/top up engine oil
 Empty, clean and refill air cleaner oil bath
 Check/top up cooling system
 Check/top up gearbox oil
 Check/top up transfer box oil
 Check/top up battery electrolyte
 Check steering rubber boots for security and damage
 Clean out brake drums and adjust to manufacturer's instructions
 Lubricate front and rear propeller shaft grease points and front sliding joint
 Clean fuel sedimentor (diesel)

Monthly

Renew gearbox oil
 Renew transfer box oil
 6 months: Renew air cleaner elements

Stationary Running

If the vehicle is used exclusively in low transfer ratio or for stationary work, maintenance intervals must be based on either fuel consumption or hours running time. Refer to the chart.

CONVERSION CHART

Kilometres and miles, fuel consumption and hours' running time

Kilometres	Miles	Fuel consumption				Hours' Running time
		Petrol		Diesel		
		Litres	Gallons	Litres	Gallons	
5000	3000	680	150	455	100	120
10000	6000	1,363	300	909	200	240
15000	9000	2,045	450	1,363	300	360
20000	12000	2,727	600	1,818	400	480
25000	15000	3,409	750	2,272	500	600
30000	18000	4,091	900	2,727	600	720
35000	21000	4,773	1,050	3,182	700	840
40000	24000	5,455	1,200	3,636	800	960

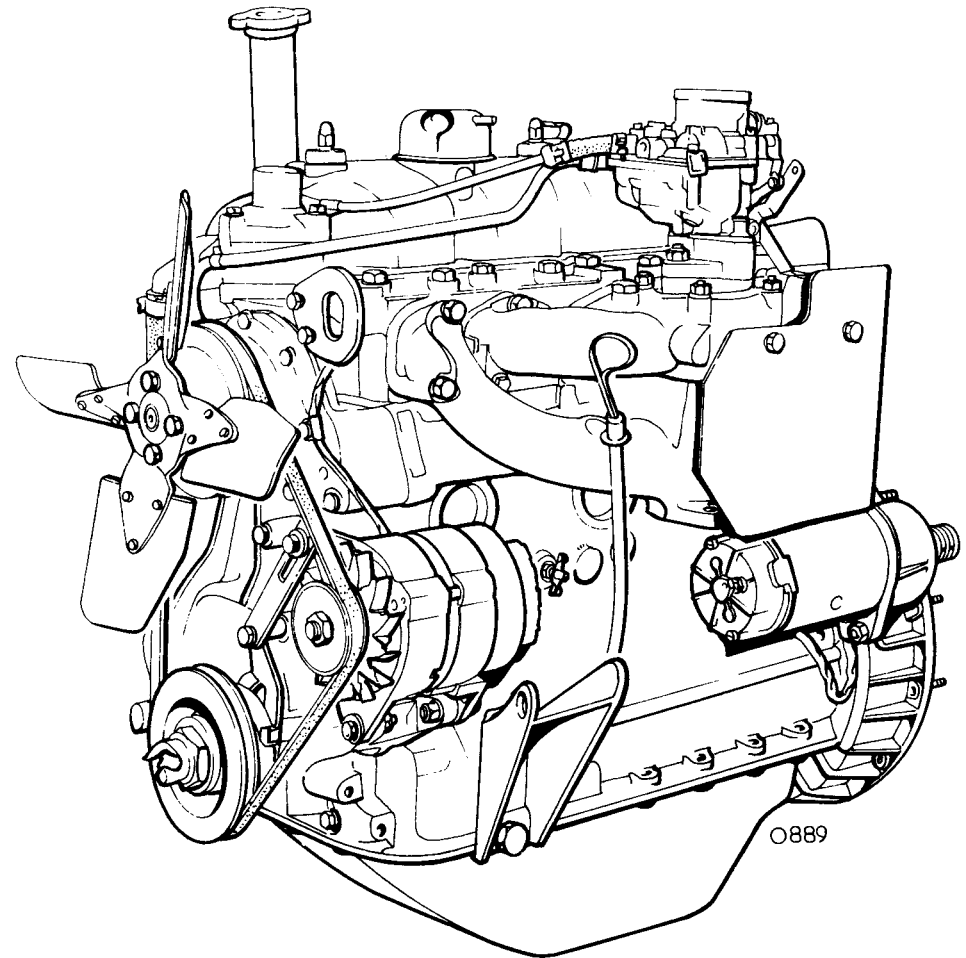
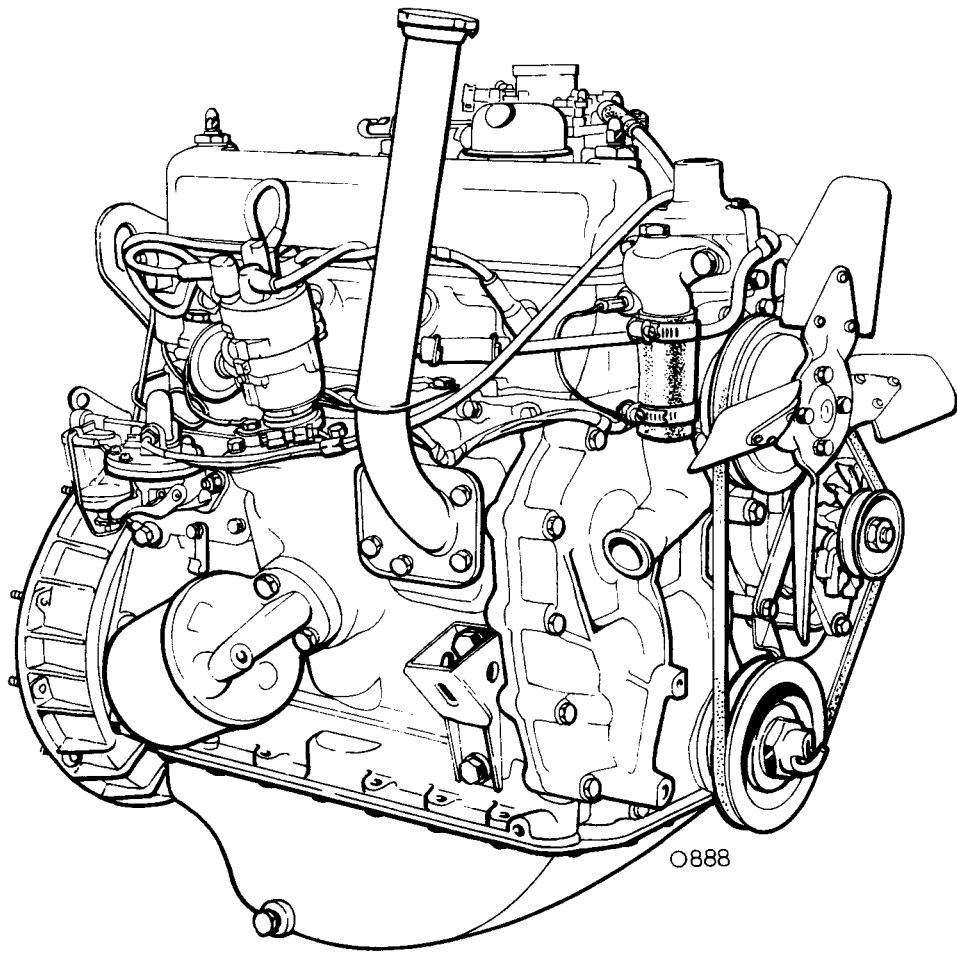

2 1/4 Litre—Three Main Bearing—4 Cylinder Petrol Engine

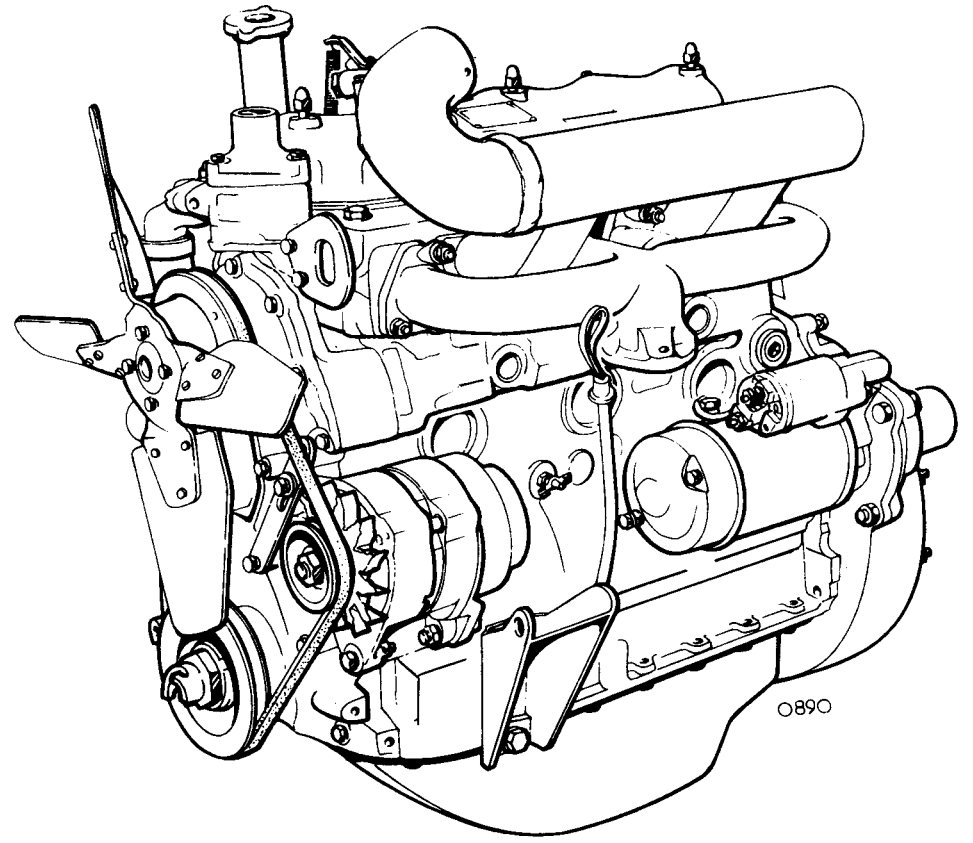
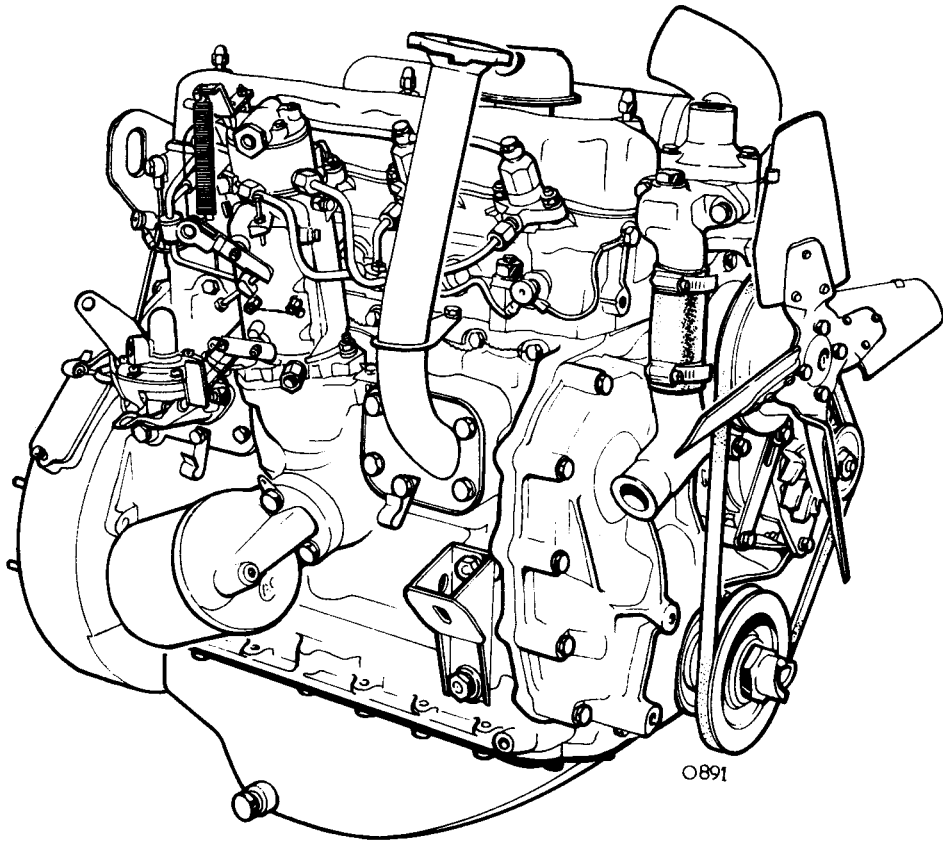

2 1/4 Litre—Three Main Bearing—4 Cylinder Diesel Engine

2½ litre — 4 cylinder Petrol and Diesel
CAMSHAFT

Remove and refit 12.13.01

Service tools: 507231 Chainwheel extractor
530101 Camshaft extractor

Removing

- 1 Remove the bonnet. 76.16.01.
- 2 Remove the air cleaner. 19.10.04.
- 3 Remove the radiator and front panel assembly. 26.40.01.
- 4 Remove the external oil filter assembly. 12.60.01.
- 5 *Petrol Engines:* Remove the distributor and drive gear. 86.35.20.
- 6 *Diesel Engines:* Remove the fuel injection pump. 19.30.07.
- 7 Remove the valve gear. 12.29.34.
- 8 Remove the cylinder head. 12.29.10.
- 9 Remove the tappets. 12.29.57.
- 10 Remove the timing gear cover. 12.65.01.
- 11 Remove the timing chain tensioner. 12.65.28.
- 12 Withdraw the timing chain.
- 13 Remove the fixings from the camshaft chainwheel.
- 14 Extract the chainwheel from the camshaft. 507231.
- 15 Remove the thrust plate from the camshaft. Tab washers deleted on later engines.
- 16 Extract the camshaft. 530101.

NOTE: For details of camshaft bearings, refer to 12.13.13.

Refitting

- 17 Insert the camshaft into the cylinder block.
- 18 Fit the thrust plate.
- 19 Fit the chainwheel to the camshaft but do not engage the lockwasher at this stage.
- 20 Mount a dial test indicator to read off the end of the camshaft.
- 21 Check the camshaft end float. The correct end float limits are 0,06 mm to 0,13 mm (0.0025 in. to 0.0055 in.). If the end float is excessive, fit a new thrust plate and/or camshaft.
- 22 Remove the dial test indicator.
- 23 Reset the valve timing. 12.65.22.
- 24 Reverse 1 to 11.

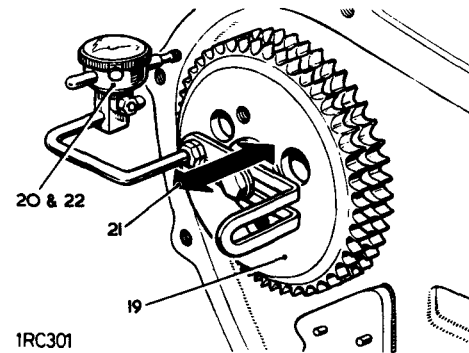
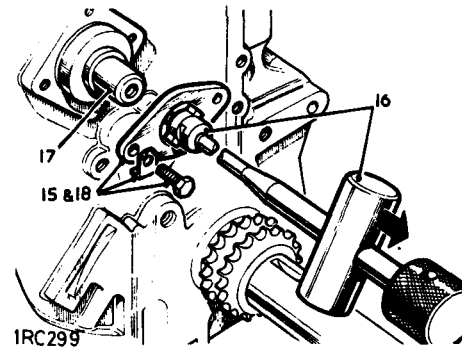
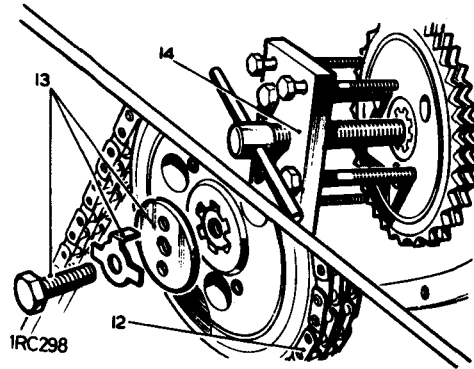

CAMSHAFT BEARINGS

Remove and refit 12.13.13.

Service tools: 605975 Bearing drift and adaptor assembly comprising:
274388 Bearing drift
531760 Adaptor
274389 Reamer for bearings includes:
274394 Guide plug

NOTE: Prior to removing the camshaft bearings, the engine must be removed from the vehicle and be completely dismantled until only the camshaft bearings remain in the cylinder block.

Removing

- 1 Drift out the front and rear bearings and withdraw them through the side cover apertures. 274388.

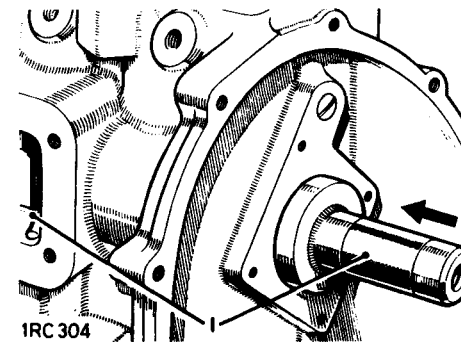

- 2 Drift the two centre bearings into the distributor drive chamber and collapse them to enable withdrawal. 274388.

Refitting

NOTE: The two centre and rear bearings are of the same width, whereas the front bearing is wider and has an additional oil feed hole.

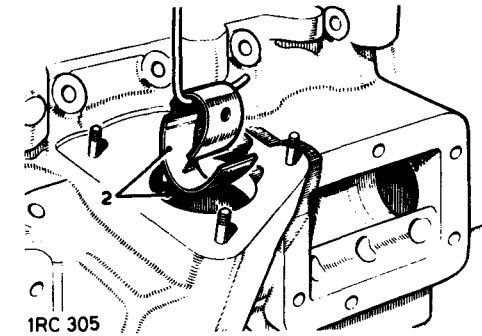

- 3 Position the cylinder block vertical, rear face down.
- 4 Place a new bearing into the front camshaft chamber and position it so that it is above the second bearing housing, counting from the front of the block.
- 5 The chamfer on the bearing edge must be towards the housing bore.

continued

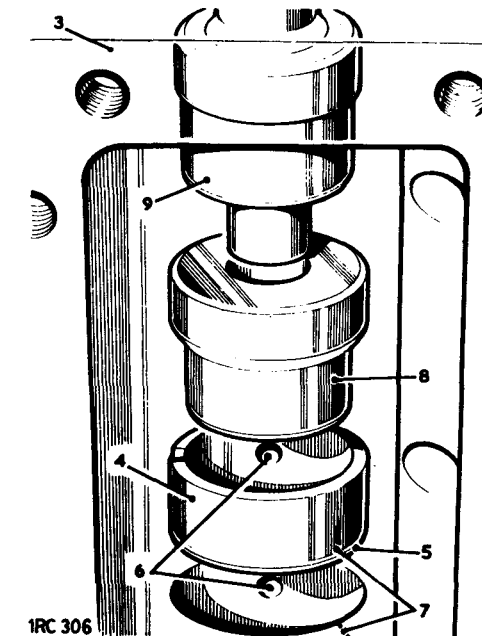

- 6 Align the oil hole in the bearing with the innermost oil feed drilling in the housing bore. Accuracy is essential otherwise misalignment of the oil holes may result and once the bearing is in place it cannot be rotated to correct any error.
- 7 Add pencil marks to the bearing outer diameter and the cylinder block adjacent to the housing to assist in checking alignment.
- 8 Having visually aligned the bearing, place inside it the adaptor. 531760.
- 9 Maintain the bearing in a level position. Pass the drift through the front bearing housing into the camshaft chamber so that it rests on top of the adaptor. Commence drifting the bearing into the block. Ensure that the bearing is not drifted in too far, and that the oil feed holes are correctly aligned.
- 10 Repeat 5 to 9 for the front bearing. Note that the front bearing is wider and has a small hole in addition to the large oil feed hole. This small hole aligns with a vertical drilling in the block, which in turn feeds a horizontal drilling for the tappet mechanism. Drift this bearing in so that the outer edge is just below the machined surface of the front face. This is to ensure that when the camshaft thrust plate is fitted it will not stand proud on the bearing edge.

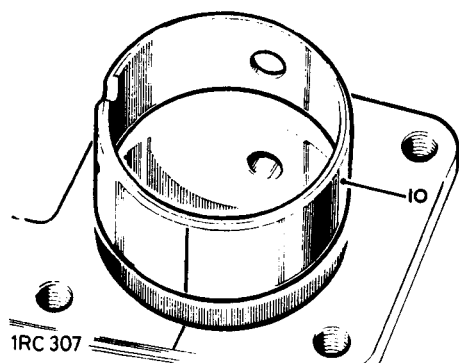

- 11 Turn the cylinder block over so that the rear face is uppermost.
- 12 Repeat the foregoing procedures for the two remaining camshaft bearings.

Reaming the camshaft bearings

NOTE: No lubricant is necessary for the reaming operation, best results are obtained when the bearings are cut dry.

- 13 Locate the guide plug 274394, into the front camshaft bearing and retain using the thrust plate screws, but do not tighten the screws at this stage.
- 14 Insert the reamer 274389 from the rear of the cylinder block, locating it through the guide plug at the front.
- 15 Locate the guide collar immediately in front of the reamer cutter into the rearmost bearing, then secure the screws retaining the guide plug at the front.
- 16 Position the cylinder block vertical, rear face uppermost.
- 17 Ream the rear and two centre bearings. As each bearing is cut the reamer should be held steady by the operator whilst an assistant, using a high pressure airline, blows away the white metal cuttings, before allowing the reamer to enter the next bearing.
- 18 Remove the guide plug 274394, before reaming the front bearing.
- 19 Ream the front bearing.
- 20 Remove the reamer handle and bolt.
- 21 Remove the reamer, turning it in the same direction as for cutting.
- 22 Remove the plugs from the ends of oil gallery passage and clean the gallery and oil feed passages to camshaft and crankshaft bearings, using compressed air. Refit the plugs and lock in position.
- 23 The hexagon-headed plugs at the rear of the block should have new washers fitted, and their threads coated with a suitable jointing compound.
- 24 Clean the cylinder block ready for engine reassembly.

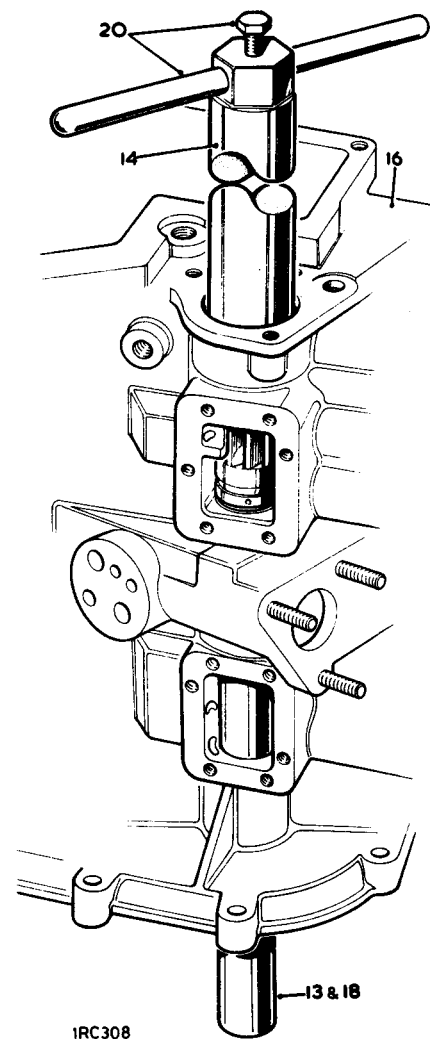

CONNECTING RODS AND PISTONS

Remove and refit

12.17.01

Removing

- 1 Remove the bonnet. 76.16.01.
- 2 Remove the air cleaner. 19.10.04.
- 3 Remove the valve gear. 12.29.34.
- 4 Remove the cylinder head. 12.29.10.
- 5 Remove the oil sump. 12.60.44.
- 6 With two pistons at bottom dead centre (BDC) remove the connecting rod cap fixings.
- 7 Remove the caps and withdraw the connecting rod bearing halves. Retain the caps and bearings in related sets.

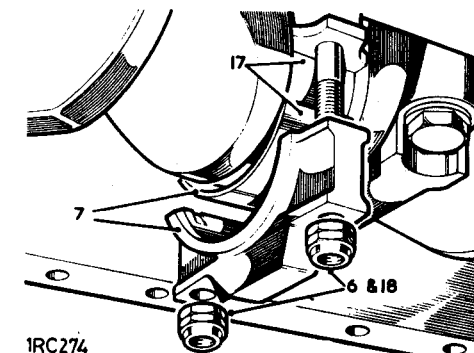

- 8 Withdraw the pistons and attached connecting rods from the top of the bore.
- 9 Position the remaining pistons at BDC and repeat the removal procedure.
- 10 Retain the removed components in related sets. The correct cap for each connecting rod is denoted by the number stamped near the joint faces. This number also indicates the crankshaft journal to which it must be fitted.

Refitting

NOTE: If replacement components are to be fitted, the checks detailed in 12.17.10 must be carried out.

- 11 Position the crankshaft with two crankpins at BDC.

- 12 Insert the appropriate connecting rod and piston assemblies into their respective bores, noting that the oil hole in the connecting rods must be towards the camshaft.
- 13 *Petrol engines:* Position the piston rings so that their gaps are staggered around the piston thrust face (camshaft side of the engine).

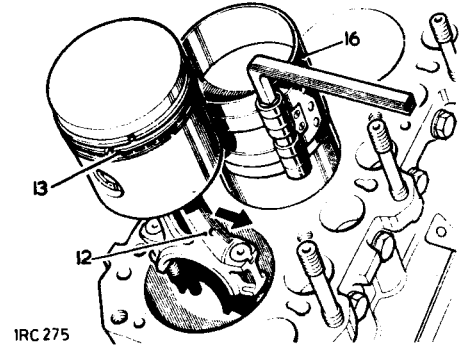

1RC 275

- 14 *Diesel engines:* Position the piston compression rings so that their gaps are staggered around the piston thrust face (camshaft side of the engine).
- 15 *Diesel engines:* Position the oil control ring so that the ends of the expander butt, but do not overlap and are in line with the gudgeon pin. Position the gap in each rail 25 mm (1 in.) to the left of the butted ends of the expander.
- 16 Using a piston ring compressor, locate the pistons into the cylinder bores.

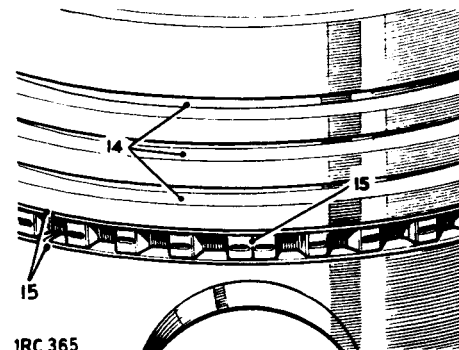

1RC 365

- 17 Lubricate the journals and bearing halves and fit the appropriate bearing halves to the connecting rods and caps.
- 18 Fit the connecting rod caps using NEW securing nuts. Torque 3,5 kgf. m (24 lbf. ft.).
- 19 Repeat 11 to 19 for the remaining connecting rod and piston assemblies.
- 20 Reverse 1 to 5.

CONNECTING RODS AND PISTONS—Petrol

Overhaul

12.17.10

Dismantling

NOTE: During the following procedures retain all components in related sets to facilitate subsequent assembly. If the same pistons are to be refitted, add location marks to ensure reassembling in the same relative position.

- 1 Remove the connecting rods and pistons. 12.17.01.
- 2 Remove the piston rings.
- 3 Remove the circlips from the gudgeon pin bosses.
- 4 Withdraw the gudgeon pins from the pistons.

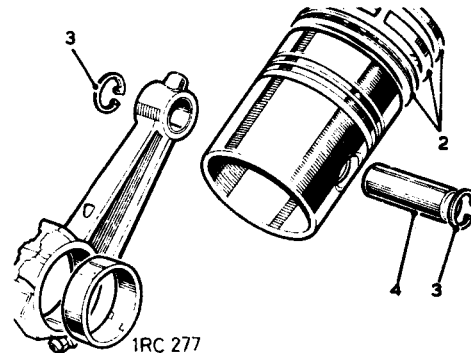

1RC 277

Overhauling pistons

Original pistons

- 5 Remove the carbon and deposits, particularly from the ring grooves.
- 6 Examine the pistons for damage or excessive wear — see under 'New pistons' for clearance dimensions — fit new replacements as necessary.

New Pistons

Original pistons fitted to new engines at the factory are specially graded to facilitate assembly. The grading letter on top of the piston crown must be ignored when ordering new pistons. Genuine Land-Rover service standard size pistons are supplied 0,025 mm (0.001 in) oversize to allow for production tolerances on new engines. When fitting a new piston to a standard size cylinder block the bore must be honed to accommodate the piston with the correct clearances.

The clearance limits with new standard size pistons and a new cylinder block are 0,058 mm to 0,068 mm (0.0023 in. to 0.0027 in.).

The clearance limits with new oversize pistons and a newly rebored cylinder block are 0,043 mm to 0,055 mm (0.0017 in. to 0.0022 in.).

The temperature of the piston and cylinder block must be the same to ensure accurate measurements.

- 7 Check the piston diameter at the bottom of the skirt at right angles to the gudgeon pin.
- 8 Check the bore diameter at approximately half way down.
- 9 If gauge equipment is not available, the piston clearance can be assessed using long feeler gauges. 10 to 12.
- 10 Insert a long suitably sized feeler gauge down the right hand side of the cylinder bore.
- 11 Insert the correct piston, inverted, into the cylinder bore and position it with the gudgeon pin parallel with the axis of the crankshaft.

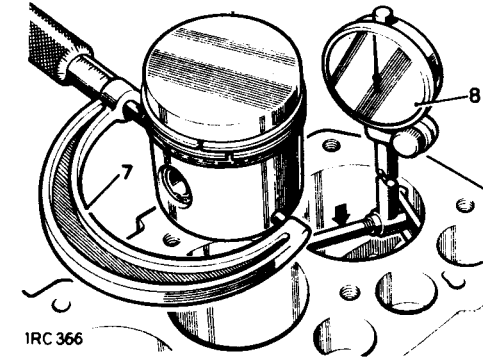

1RC 366

- 12 Push the piston down the cylinder until the piston reaches its tightest point in the bore, at this point withdraw the feeler gauge — a steady resistance should be felt.

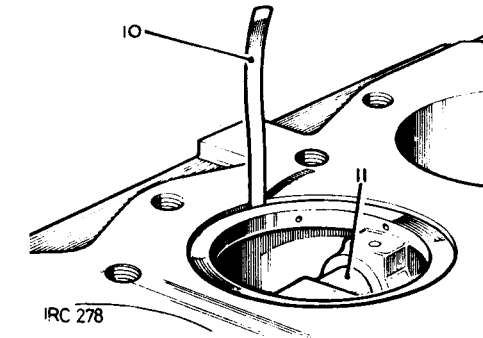

1RC 278

- 13 If service standard size pistons are being fitted, check the diameter of the piston, as already described, and hone the cylinder bore, as necessary, to obtain the correct clearance.

continued

- 14 If new piston rings are to be fitted without reboring, deglaze the cylinder walls with a hone, without increasing the bore diameter. A deglazed bore must have a cross-hatch finish.
- 15 Check the compression and oil control ring gaps in the applicable cylinder, held square to the bore with the piston. Gap limits: 0,38 mm to 0,5 mm (0.015 in. to 0.020 in.). Use a fine cut flat file to increase the gap if required. Select a new piston ring if the gap exceeds the limit.

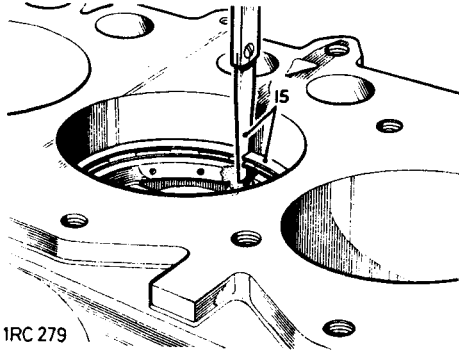

IRC 279

- 16 Fit the oil control ring to the piston.
- 17 Check the oil control ring clearance in the piston groove. Clearance limits: 0,038 mm to 0,089 mm (0.0015 in. to 0.0035 in.).
- 18 Fit the two compression rings to the piston with the sides marked 'T' or 'Top' uppermost.
- 19 Check the compression ring clearance in the piston grooves. Clearance limits: 0,046 mm to 0,097 mm (0.0018 in. to 0.0038 in.).

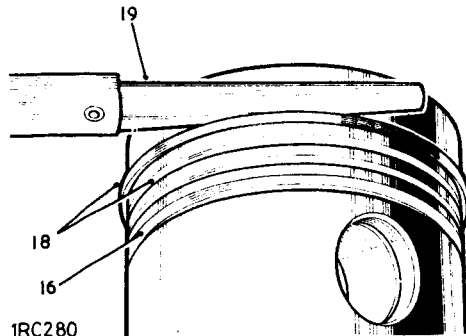

IRC 280

Where maximum permitted boring tolerance is not sufficient to reclaim the bores, cylinder liners must be fitted.

Fitting the cylinder liners conforms to normal practice. Machine the cylinder block bores to 94,425 mm + 0,012 mm (3.7175 in. + 0.0005 in.) diameter. This will provide the liner with 0,076 mm to 0,114 mm (0.003 in. to 0.0045 in.) interference fit.

Press the liners into the cylinder block. The liners must not be proud of, or more than 0,254 mm (0.010 in.) below, the top face of the cylinder block.

Cylinder liners should be bored to standard size of 90,47 mm (3.562 in.) diameter. Liners may be rebored to a maximum of 1,01 mm (0.040 in.) oversize.

Connecting rods

- 20 Check the alignment of the connecting rod.
- 21 Check the gudgeon pin clearance in the connecting rod. Clearance limits: 0,007 mm to 0,015 mm (0.0003 in. to 0.0006 in.).
- 22 If a new connecting rod small end bush is required, ensure that the oil holes are aligned when pressing in the replacement, then ream the bush to obtain the correct clearances, as above.

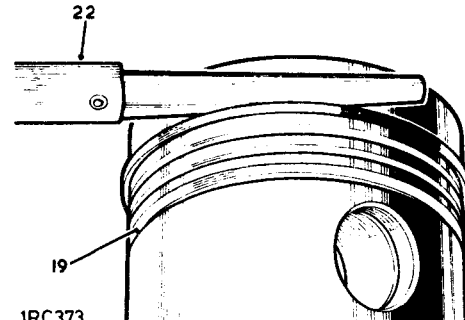

IRC 373

- 23 Check the fit of the gudgeon pin in the piston, the pin must not fall through either boss but be capable of being fitted by hand at normal room temperature 20°C (68°F.).

- 24 Select the correct cap for each connecting rod as denoted by the number stamped near the joint faces. This number also indicates the crankshaft journal to which it must be fitted.
- 25 Assemble the caps, less bearing halves, to the respective connecting rods. Torque 3,5 kgf. m (25 lb. ft.).
- 26 Slacken the fixing on one side of the cap only and check that there is no clearance at the joint face. If there is clearance, a new assembly must be fitted.

Connecting rod bearing nip and clearance

NOTE: New bearing halves are supplied with a protective coating and must be degreased, prior to fitting, to remove the coating.

- 27 Fit the bearing halves to the connecting rod and cap, and secure the assembly. Torque 3,5 kgf. m (25 lb. ft.).
- 28 Slacken the fixing on one side of the cap only and check the clearance between the joint faces. The clearance must be 0,10 mm to 0,20 mm (0.004 in. to 0.008 in.). The bearing nip can be corrected by selective assembly of the bearing shells; these are available in slightly varying thicknesses. Do not file or machine the caps or connecting rods to vary the bearing nip.

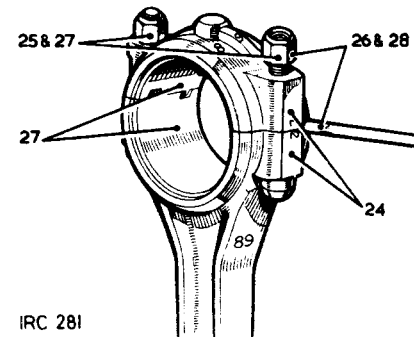

IRC 281

- 29 Make a final check to prove the bearing clearance, using a 0,063 mm (0.0025 in.) shim paper. The connecting rod should resist rotation when fitted to the crankshaft with the shim paper fitted between the journal and one half of the bearing shell, and move freely by hand with the shim paper removed.

NOTE: As an alternative, Plastigauge may be used to check the connecting rod bearing clearance. 30 to 36.

Do not rotate the connecting rod or crankshaft while the Plastigauge is fitted, or the reading will be impaired.

- 30 Place a piece of Plastigauge across the centre of the lower half of the crankshaft journal. 605238.
- 31 Fit the connecting rod complete with bearings to the applicable journal. Torque 3,5 kgf. m (25 lb. ft.).
- 32 Remove the connecting rod cap and lower half bearing.
- 33 Using the scale printed on the Plastigauge packet, measure the flattened Plastigauge at its widest point. The graduation that most closely corresponds to the width of the Plastigauge indicates the bearing clearance.

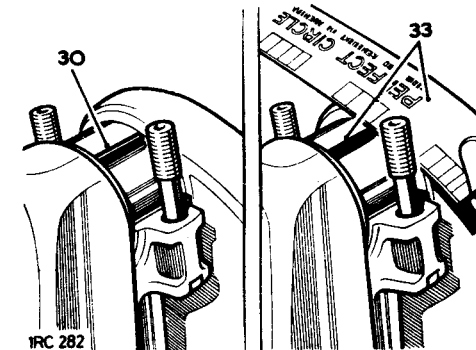

IRC 282

- 34 The correct clearance with new or overhauled components is given in DATA at the end of this operation.
- 35 If a new bearing is being fitted, use selective assembly to obtain the correct clearance.

36 Wipe off the Plastigauge with an oily rag. DO NOT scrape it off.

Connecting rod end float

- 37 Fit the connecting rods complete with bearings to their applicable journals. Torque 3,5 kgf. m (25 lbf. ft.).
- 38 Check the end float between the end face of the connecting rod and the journal shoulder. End float limits: 0,20 mm to 0,30 mm (0.007 in. to 0.012 in.).
- 39 Remove the connecting rods from the crankshaft and retain all parts in related sets.

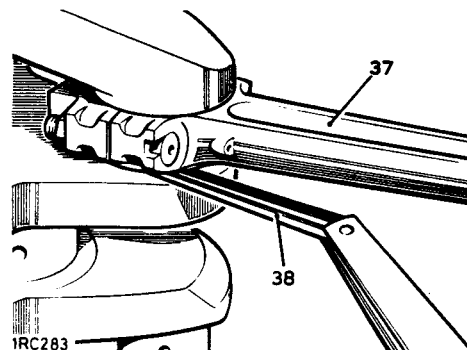

Assembling

- 40 Assemble the pistons to their respective connecting rods.

- 41 Fit new circlips to retain the piston gudgeon pins.
- 42 Refit the connecting rods and pistons 12.17.01.

DATA

Pistons

Clearance in bore, measured at bottom of skirt at right angles to gudgeon pin.

Standard size pistons	0,058 mm to 0,068 mm (0.0023 in. to 0.0027 in.)
Oversize pistons	0,043 mm to 0,055 m (0.0017 in. to 0.0022 in.)

Piston Rings

Compression (2)

Gap in bore	0,38 mm to 0,50 mm (0.015 in. to 0.020 in.)
Clearance in groove	0,046 mm to 0,097 mm (0.0018 in. to 0.0038 in.)

Oil control

Gap in bore	0,38 mm to 0,50 mm (0.015 in. to 0.020 in.)
Clearance in groove	0,038 mm to 0,089 mm (0.0015 in. to 0.0035 in.)

Gudgeon pin

Clearance in connecting rod	0,007 mm to 0,015 mm (0.0003 in. to 0.0006 in.)
Fit in piston	Push fit by hand

Connecting Rods

Clearance, bearing to crankpin	0,019 mm to 0,068 mm (0.00075 in. to 0.0027 in.)
End float on crankpin	0,20 mm to 0,30 mm (0.007 in. to 0.012 in.)

CONNECTING RODS AND PISTONS – Diesel

Overhaul

12.17.10

Dismantling

NOTE: During the following procedures retain all components in related sets to facilitate subsequent assembly. If the same pistons are to be refitted, add location marks to ensure reassembling in the same relative position.

- 1 Remove the connecting rods and pistons. 12.17.01.
- 2 Remove the piston rings.
- 3 Remove the circlips from the gudgeon pin bosses.
- 4 Withdraw the gudgeon pins from the pistons.

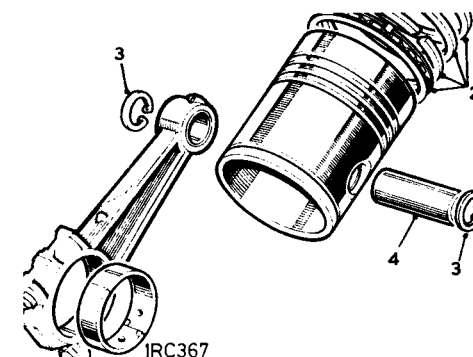

New Pistons

Original pistons fitted to new engines at the factory are specially graded to facilitate assembly. The grading letter on top of the piston crown must be ignored when ordering new pistons. Genuine Land-Rover Service standard size pistons are supplied 0,025 mm (0.001 in) oversize to allow for production tolerances on new engines. When fitting a new piston to a standard size cylinder block the bore must be honed to accommodate the piston with the correct clearances.

The clearance limits with new standard size pistons and a new cylinder block are 0,111 mm to 0,134 mm (0.0044 in. to 0.0053 in.).

The clearance limits with new oversize pistons and a newly rebored cylinder block are 0,111 mm to 0,157 mm (0.0044 in. to 0.0062 in.).

The temperature of the piston and cylinder block must be the same to ensure accurate measurements.

- 7 Check the piston diameter at the extreme bottom and at right angles to the gudgeon pin.
- 8 Check the bore diameter at approximately half way down, at right angles to the gudgeon pin.

continued

Overhauling Pistons

Original Pistons

- 5 Remove the carbon and deposits, particularly from the ring grooves.
- 6 Examine the pistons for damage or excessive wear – see under 'New pistons' for clearance dimensions – fit new replacements as necessary.

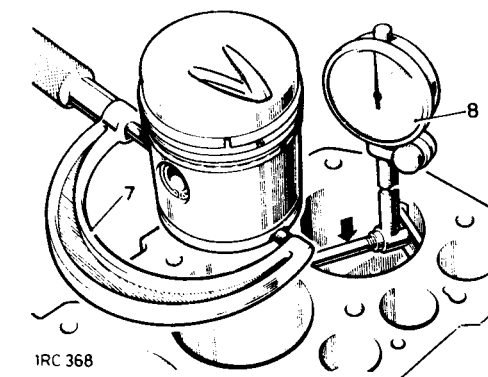

- 9 If gauge equipment is not available, the piston clearance can be assessed using long feeler gauges. 10 to 12.
- 10 Insert a long, suitably sized feeler gauge down the right hand side of the cylinder bore.
- 11 Insert the correct piston, inverted, into the cylinder bore and position it with the gudgeon pin parallel with the axis of the crankshaft.

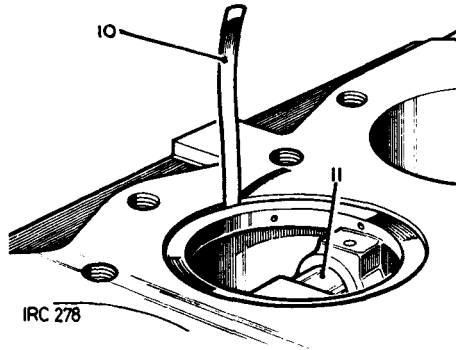

IRC 278

- 12 Push the piston down the cylinder until the piston reaches its tightest point in the bore, at this point withdraw the feeler gauge - a steady resistance should be felt.
- 13 If service standard size pistons are being fitted, check the diameter of the piston, as already described, and hone the cylinder bore, as necessary, to obtain the correct clearance.
- 14 If new piston rings are to be fitted without reboring, deglaze the cylinder with a hone, without increasing the bore diameter. A deglazed bore must have a cross-hatch finish.
- 15 Check the compression and oil control ring gaps in the applicable cylinder, held square to the bore with the piston. Gap limits: Upper compression ring (chromed): 0,35 mm to 0,50 mm (0.014 in. to 0.019 in.). Middle and lower compression rings: 0,25 mm to 0,38 mm (0.010 in. to 0,015 in.). Oil control ring, upper and lower rail: 0,38 mm to 1,14 mm (0.015 in. to 0.045 in.).

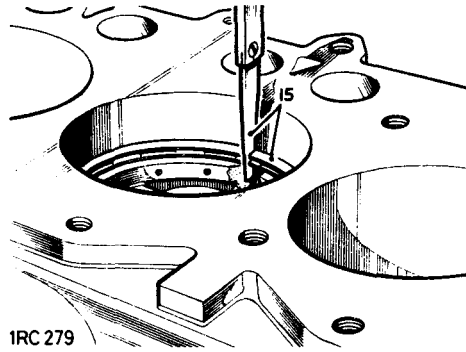

IRC 279

- 16 Fit the expander for the oil control ring into the groove immediately above the gudgeon pin. The ends of the expander must butt but not overlap and be in line with the gudgeon pin.
- 17 Fit the lower rail from the bottom of the piston and locate it into the groove, beneath the expander. Position the ring gap 25 mm (1 in.) to the left of the butted ends of the expander.
- 18 Fit the upper rail from the top of the piston and locate it into the groove, above the expander. Position the ring gap 25 mm (1 in.) to the left of the butted ends of the expander.

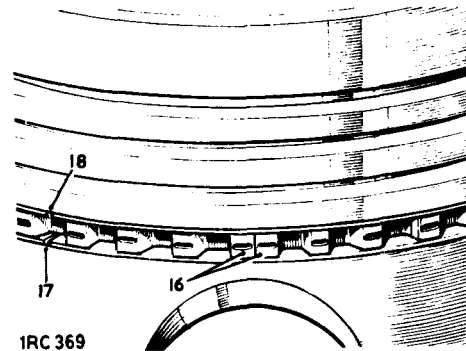

IRC 369

- 19 Check the oil control ring clearance in the piston groove. Clearance limits: 0,038 mm to 0,064 mm (0.0015 in. to 0.0025 in.).

- 20 Fit the compression rings marked 'T' or 'TOP' with the marking uppermost to the middle two grooves.
- 21 Fit the chrome edged compression ring to the top groove.
- 22 Check the compression ring clearance in the piston grooves. Clearance limits: 0,06 mm to 0,11 mm (0.0025 in. to 0.0045 in.).

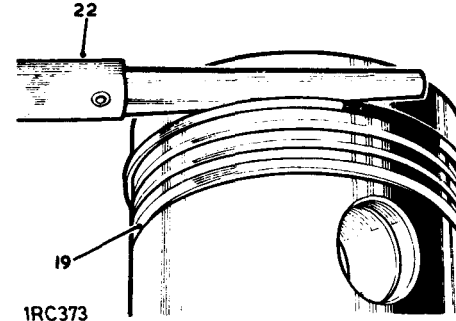

IRC 373

Where the maximum permitted boring tolerance is not sufficient to reclaim the bores, cylinder liners may be fitted. Fitting the cylinder liners conforms to normal practice. Machine the cylinder block bores to 94,425 mm + 0,012 mm (3.7175 in. + 0.0005 in.) diameter. This will provide the liner with 0,076 mm to 0,0114 mm (0.003 in. to 0.0045 in.) interference fit. Press the liners into the cylinder block. The liners must not be proud of, or more than 0,05 mm (0.002 in.) below the top face of the cylinder block. Cylinder liners should be bored to standard size of 90,47 mm (3.562 in.) diameter. Liners may be rebored to a maximum of 1,01 mm (0.040 in.) oversize.

Connecting rods

- 23 Check the alignment of the connecting rod.
- 24 Check the gudgeon pin clearance in the connecting rod. Clearance limits: 0,002 mm to 0,02 mm (0.0001 in. to 0.0009 in.).
- 25 If a new connecting rod small end bush is required, ensure that the oil holes are aligned when pressing in the replacement, then ream the bush to obtain the correct clearance, as above.

- 26 Check the fit of the gudgeon pin in the piston, the pin must not fall through either boss but be capable of being fitted by hand at normal room temperature 20°C (68°F).
- 27 Select the correct cap for each connecting rod as denoted by the number stamped near the joint faces. This number also indicates the crankshaft journal to which it must be fitted.
- 28 Assemble the caps, less bearing halves, to the respective connecting rods. Torque 3,5 kgf. m (25 lbf. ft.).
- 29 Slacken the fixing on one side of the cap only and check that there is no clearance at the joint face. If there is clearance, a new assembly must be fitted.

Connecting rod bearing nip and clearance
NOTE: New bearing halves are supplied with a protective coating and must be degreased prior to fitting to remove the coating.

- 30 Fit the bearing halves to the connecting rod and cap and secure the assembly. Torque 3,5 kgf. m (25 lbf. ft.).
- 31 Slacken the fixing on one side of the cap only and check the clearance between the joint faces. The clearance must be 0,10 mm to 0,20 mm (0.004 in. to 0.008 in.). The bearing nip can be corrected by selective assembly of the bearing shells; these are available in slightly varying thicknesses. Do not file or machine the caps or connecting rods to vary the bearing nip.

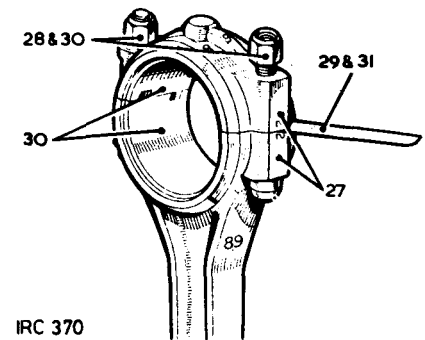

IRC 370

32 Make a final check to prove the bearing clearance, using a 0,063 mm (0.0025 in.) shim paper. The connecting rod should resist rotation when fitted to the crankshaft with the shim paper fitted between the journal and one half of the bearing shell, and move freely by hand with the shim paper removed.

NOTE: As an alternative, Plastigauge may be used to check the connecting rod bearing clearance. Do not rotate the connecting rod or crankshaft while the Plastigauge is fitted, or the reading will be impaired.

33 Place a piece of Plastigauge across the centre of the lower half of the crankshaft journal. 605238.

34 Fit the connecting rod complete with bearings to the applicable journal. Torque 3,5 kgf. m (25 lbf. ft.).

35 Remove the connecting rod cap and lower half bearing.

36 Using the scale printed on the Plastigauge packet, measure the flattened Plastigauge at its widest point. The graduation that most closely corresponds to the width of the Plastigauge indicates the bearing clearance.

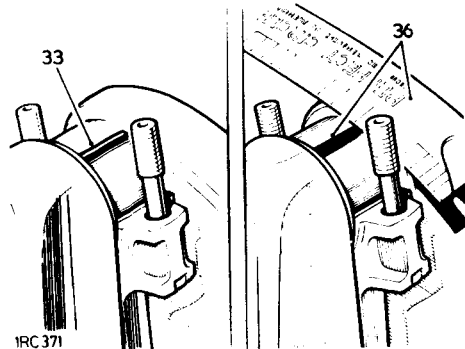

37 The correct clearance with new or overhauled components is given in the DATA at the end of this operation.

38 If a new bearing is being fitted, use selective assembly to obtain the correct clearance.

39 Wipe off the Plastigauge with an oily rag. DO NOT scrape it off.

Connecting rod end float

40 Fit the connecting rods complete with bearings to their applicable journals. Torque 3,5 kgf. m (25 lbf. ft.).

41 Check the end float between the end face of the connecting rod and the journal shoulder. End float limits: 0,20 mm to 0,30 mm (0.007 in. to 0.012 in.).

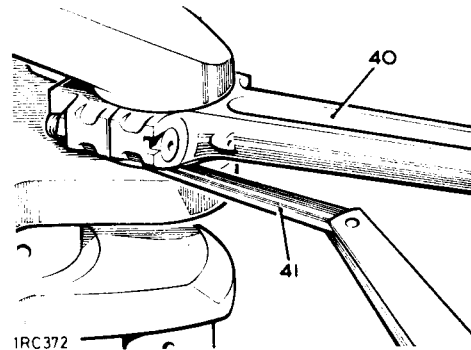

42 Remove the connecting rods from the crankshaft and retain all parts in related sets.

Assembling

43 Assemble the pistons to their respective connecting rods.

44 Fit new circlips to retain the piston gudgeon pins.

45 Refit the connecting rods and pistons. 12.17.01.

DATA

Pistons

Clearance in bore measured at bottom of skirt at right angles to gudgeon pin.

Standard size pistons	0,111 mm to 0,134 mm (0.0044 in. to 0.0053 in.)
Oversize pistons	0,111 mm to 0,157 mm (0.0044 in. to 0.0062 in.)

Piston rings

Compression No. 1

Type	Square friction edge – chromium plated
Gap in bore	0,35 mm to 0,50 mm (0.014 in. to 0.019 in.)
Clearance in groove	0,06 mm to 0,11 mm (0.0025 in. to 0.0045 in.)

Compression Nos. 2 and 3

Type	Bevelled friction edge. Marked 'T' or 'TOP' on upper side.
Gap in bore	0,25 mm to 0,38 mm (0.010 in. to 0.015 in.)
Clearance in groove	0,06 mm to 0,11 mm (0.0025 in. to 0.0045 in.)

Oil control No. 4

Type	Expander and rails
Gap in bore	0,38 mm to 1,14 mm (0.015 in. to 0.045 in.)
Clearance in grove	0,038 mm to 0,064 mm (0,0014 in. to 0.0025 in.)

Gudgeon pin

Clearance in connecting rod	0,002 mm to 0,020 mm (0.0001 in. to 0.0008 in.)
Fit in piston	Push fit by hand

Connecting rods

Clearance, bearing to crankpin	0,019 mm to 0,068 mm (0.00075 in. to 0.0027 in.)
End float on crankpin	0,20 mm to 0,30 mm (0.007 in. to 0,012 in.)

CRANKSHAFT REAR OIL SEAL

Remove and refit

12.21.20

Service Tools: 270304 Guides for oil seal
600963 Engine lifting sling

Removing

- 1 Remove the bonnet. 76.16.01.
- 2 Remove the front floor. 76.10.12.
- 3 Remove the engine assembly. 12.41.01.
- 4 Remove the starter motor. 86.60.01.
- 5 Remove the oil sump. 12.60.44.
- 6 Remove the clutch assembly. 33.10.01.
- 7 Remove the flywheel. 12.53.07.
- 8 Remove the flywheel housing.
- 9 Remove the oil seal ring.

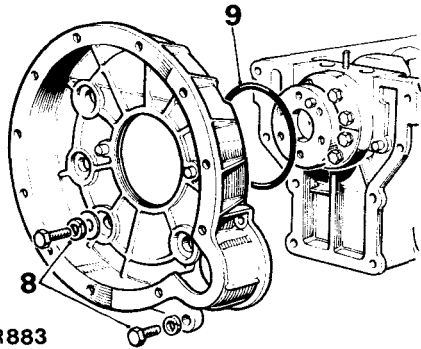

LR883

- 10 Remove the rear main bearing cap.
- 11 Remove the lower half of the oil seal retainer from the rear main bearing cap.
- 12 Remove the upper half of the oil seal retainer from the cylinder block, by rotating the crankshaft to align the cut-out with the fixings.

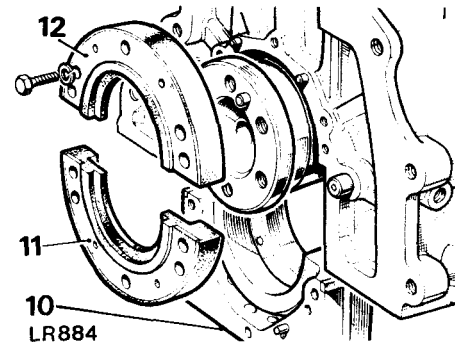

LR884

- 13 Remove the oil seal from the crankshaft.

Refitting

- 14 Assemble the garter spring on the crankshaft journal by engaging the hook and eye. Do not stretch the spring.
- 15 Move the assembled spring along the journal until it is against the thrower flange.
- 16 Apply Silicone Grease MS4 to the crankshaft oil seal journal and to both end faces of the split oil seal.
- 17 Open the split seal sufficiently to allow it to be fitted over the crankshaft oil seal journal. The recess in the oil seal must be towards the thrower flange and the garter spring.

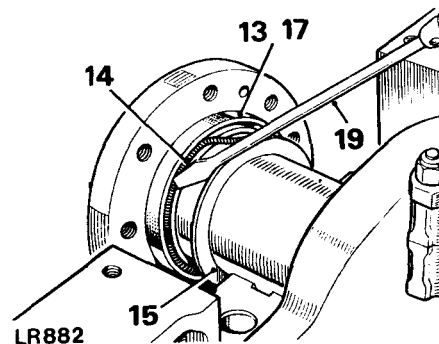

LR882

NOTE: The oil seal must not be repeatedly fitted and removed from the crankshaft, as this can damage the sealing lip.

- 18 Position the garter spring so that the hook and eye is located mid-way between the split and hinge of the oil seal.
- 19 Using a small screwdriver, ease the spring into the recess in the oil seal.
- 20 Rotate the oil seal until the split is on the vertical axis pointing towards the cylinder head and in its approximate running position on the journal; this position is important.

NOTE: Do not degrease the seal retainer halves with trichlorethylene, but wipe clean with a dry cloth prior to applying Hylomar.

- 21 Apply Hylomar PL 32/M jointing compound, to the seal location diameter of both retainer halves.
- 22 Locate one half of the oil seal retainer onto the cylinder block dowels. The oil seal should be compressed to assist assembly, also ensure that it is correctly located in the retainer recess.

CAUTION: The seal must be held so that it does not rotate when the crankshaft is being rotated to fit the retainer securing bolts.

- 23 Secure the upper half of the oil seal retainer with the three inner bolts, leaving the outer bolt at each end finger tight at this stage.
- 24 Secure the lower half of the oil seal retainer to the rear main bearing cap in the same manner as described for the upper half.
- 25 Apply Silicone Grease MS4 to the 'T' seals and fit them to the rear main bearing cap.
- 26 Trim the top edges of the 'T' seals to prevent them from fouling the cylinder block when being fitted.
- 27 Fit the seal guides to the crankcase. 270304.

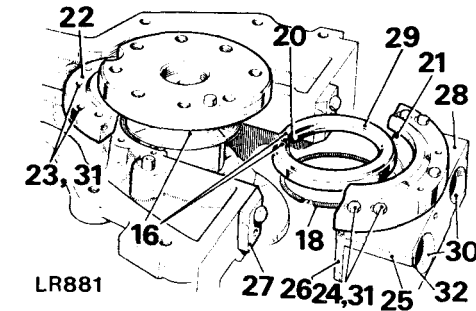

LR881

- 28 Fit the rear main bearing cap complete with the seal retainer, 'T' seals and bearing shell to the crankcase until there is an 0,8 mm (0.030 in.) gap between the cap and the crankcase.
- 29 Check that the seal is correctly located in the retainer recess.
- 30 Tighten the bearing cap bolts ensuring that there is no buckling of the split seal or misalignment of the butt joint. Torque: Petrol engines: 11,5 kgf. m (85 lbf. ft.). Diesel engines: 13,8 kgf. m (100 lbf. ft.).
- 31 Fully tighten all the bolts securing the retainer halves. Turn the bolt heads so that the hexagon corners will not foul the flywheel housing seal when fitting.
- 32 Trim the ends of the 'T' seals to leave 0,8 mm (0.030 in.) protruding from the bearing cap.
- 33 Reverse 1 to 9.

CRANKSHAFT

Remove and refit 12.21.33

Removing

- 1 Remove the bonnet. 76.16.01.
- 2 Remove the air cleaner. 19.10.04.
- 3 Remove the radiator and front panel assembly. 26.40.01.
- 4 Remove the front floor. 76.10.12.
- 5 Remove the engine assembly. 12.41.01.
- 6 Remove the oil sump. 12.60.44.
- 7 Remove the oil pump. 12.60.26.
- 8 Remove the timing gear cover. 12.65.01.
- 9 Remove the timing chain and tensioner. 12.65.28.
- 10 Remove the clutch assembly. 33.10.01.
- 11 Remove the flywheel. 12.53.07.
- 12 Remove the flywheel housing.
- 13 Remove the oil seal ring.
- 14 Remove the connecting rod caps and bearing lower halves. Retain in related sets.

- 15 Remove the main bearing caps and lift the crankshaft clear. Retain the bearing halves in related sets.
- 16 Remove the oil seal from the crankshaft.
- 17 Remove the upper half of the oil seal retainer from the cylinder block.
- 18 If required, remove the chainwheel and key from the crankshaft.

Refitting

NOTE: If replacement components are to be fitted, the checks detailed in 12.21.46 must be carried out.

- 19 Locate the upper main bearing halves into the cylinder block.
- 20 Lubricate the bearings and crankshaft journals with clean engine oil, and place the crankshaft in position.
- 21 Insert a thrust washer at each side of the centre main bearing shell with the unplated faces towards the cylinder block.

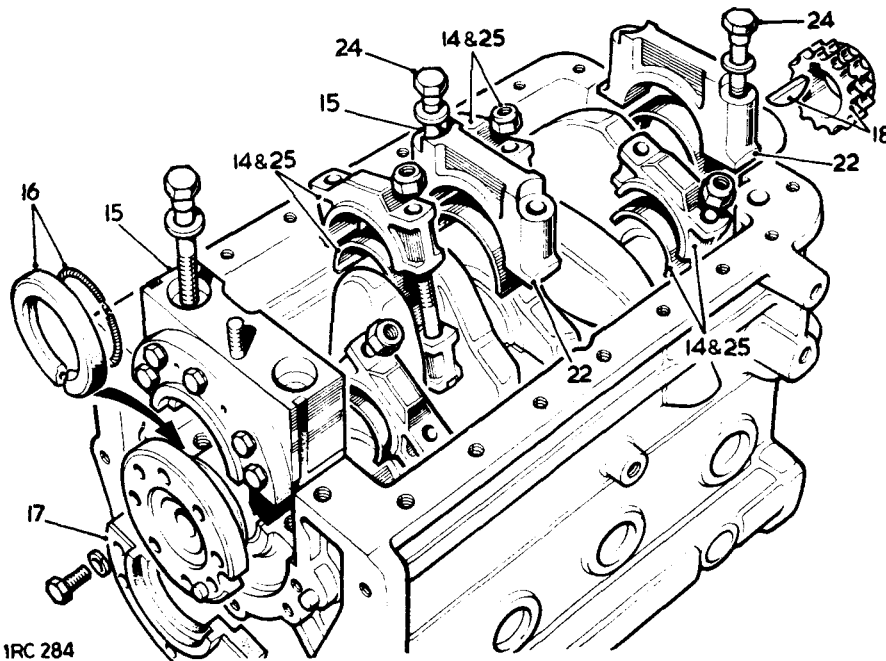

1RC 284

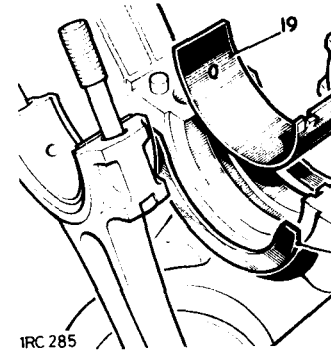

1RC 285

- 22 Locate the bearing lower halves into the front and centre main bearing caps. Fit the caps but do not fully tighten the fixings at this stage.
- 23 Fit the crankshaft rear oil seal. 12.21.20.
- 24 Tighten the front and centre main bearing cap fixings. Torque: Petrol engines: 11,5 kgf. m (85 lbf. ft.). Diesel engines: 13,8 kgf. m (100 lbf. ft.).
- 25 Fit the appropriate bearing halves and caps to the connecting rods, using NEW securing nuts. Torque: 3,5 kgf. m (25 lbf. ft.).
- 26 Fit the oil seal ring to the flywheel housing.
- 27 Refit the flywheel housing.

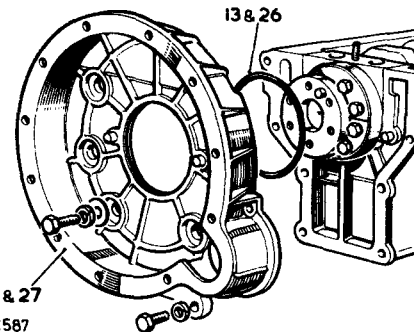

12&27
1RC 587

- 28 Refit the flywheel. 12.53.07.
- 29 Refit the clutch assembly. 33.10.01.
- 30 Reset the valve timing. 12.65.22.
- 31 Reverse 1 to 9.

CRANKSHAFT

Overhaul 12.21.46

CAUTION: DO NOT fit an undersize crankshaft to a Diesel engine. When a Diesel engine crankshaft is worn, a new standard size replacement must be fitted, carrying out the following checks (except item 3).

- 1 Remove the crankshaft. 12.21.33.

Inspecting

- 2 Check each crankshaft journal for ovality. If ovality exceeds 0,040 mm (0.0015 in.), a reground or new crankshaft should be fitted.
- 3 *Petrol Engines:* Bearings for the crankshaft main journals and the connecting rod journals are available in the following undersizes:
0,25 (0.010 in.).
0,50 mm (0.020 in.).
0,76 mm (0.030 in.).
1,01 mm (0.040 in.).
- 4 Thrust washers for the crankshaft main journal, to control the crankshaft end float, are available in the following oversizes:
0,06 mm (0.0025 in.).
0,12 mm (0.005 in.).
0,18 mm (0.0075 in.).
0,25 mm (0.010 in.).
- 5 Fit the front main bearing cap, less bearing halves, to the cylinder block. Torque: Petrol engines: 11,75 kgf. m (85 lbf. ft.). Diesel engines: 13,8 kgf. m (100 lbf. ft.).
- 6 Slacken the fixing on one side of the cap only and check that there is no clearance at the joint face. If there is clearance, a complete new cylinder block must be fitted.
- 7 Repeat 5 and 6 for the centre and rear main bearing caps.

Main bearing nip and clearance

NOTE: New bearing halves are supplied with a protective coating and must be degreased prior to fitting, to remove the coating.

- 8 Locate the bearing halves into the front main bearing cap and the cylinder block, and fit the cap to the block. Torque: Petrol engines: 11,75 kgf. m (85 lbf. ft.). Diesel engines: 13,8 kgf. m (100 lbf. ft.).
- 9 Slacken the fixing on one side of the cap only and check the clearance between the joint faces. The clearance must be 0,10 mm to 0,15 mm (0.004 in. to 0.006 in.).

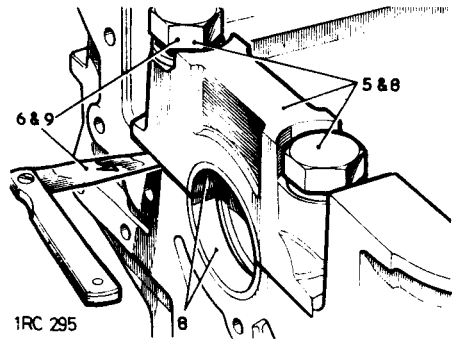

- 10 The bearing nip can be corrected by selective assembly of the bearing halves; these are available in slightly varying thicknesses. Do not file or machine the caps or cylinder block to vary the bearing nip.
- 11 Repeat 8 to 10 for the centre and rear main bearings.
- 12 When the bearing nip has been checked, remove the caps and bearing shell bottom halves.
- 13 Position a standard size thrust washer each side of the centre main bearing shell, top half, with the unplated faces towards the cylinder block. The thrust washer thickness must agree within 0,08 mm (0.003 in.).
- 14 Place the crankshaft in position on the cylinder block.
- 15 Mount a dial test indicator to read off the end of the crankshaft.
- 16 Check the crankshaft end float limits are 0,05 mm to 0,15 mm (0.002 in. to 0.006 in.).

- 17 The crankshaft end float can be adjusted by fitting oversize thrust washers. The variation of thrust washer thickness at each side must not exceed 0.08 mm (0.003 in.) to ensure that the crankshaft remains centred.

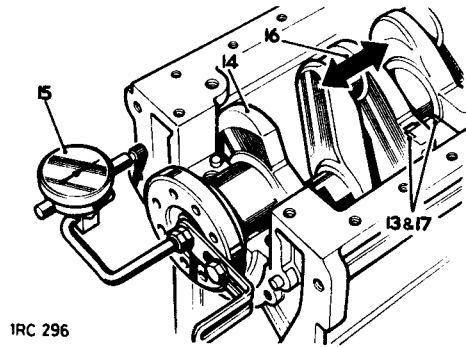

- 18 Make a final check to prove the main bearing clearance, using a 0,063 mm (0.0025 in.) shim paper. Check each bearing in turn by fitting both bearing halves and the bearing cap, with the shim paper between the crankshaft and one half of the bearing. The crankshaft should resist rotation with the shim paper fitted, and move freely by hand with the shim paper removed.

NOTE: As an alternative, Plastigauge may be used to check the main bearing clearance 19 to 26. Do not rotate the crankshaft while the Plastigauge is fitted, or the reading will be impaired.

- 19 Locate the crankshaft in position on the upper bearing halves in the cylinder block.
- 20 Place a piece of Plastigauge across the centre of the lower half of the crankshaft journal. 605238.
- 21 Fit the bearing cap complete with the lower bearing half. Torque: Petrol engines: 11,75 kgf. m (85 lbf. ft.). Diesel engines: 13,8 kgf. m (100 lbf. ft.).
- 22 Remove the bearing cap and lower half bearing.

- 23 Using the scale printed on the Plastigauge packet, measure the flattened Plastigauge at its widest point. The graduation that most closely corresponds with the width of the Plastigauge indicates the bearing clearance.

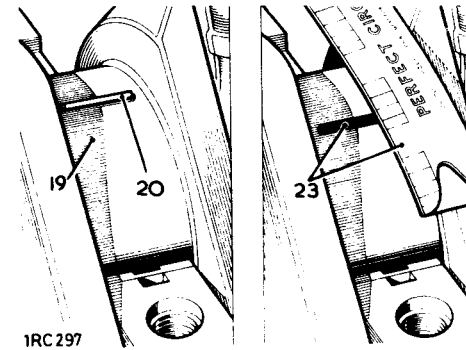

- 24 The correct clearance with new or overhauled components is 0,020 mm to 0,055 mm (0.0008 in. to 0.0028 in.).
- 25 If a new bearing is being fitted, use selective assembly to obtain the correct clearance.
- 26 Wipe off the Plastigauge with an oily rag. DO NOT scrape it off.
- 27 Retain all components in related sets.
- 28 Refit the crankshaft. 12.21.33.

DATA

Crankshaft

Journal diameter	63,5 mm – 0,012 mm (2.5 in. – 0.0005 in.)
Crankpin diameter	58,7 mm (2.312 in.)
End float (controlled by thrust washers at centre bearing)	0,05 mm to 0,15 mm (0.002 to 0.006 in.)
Regrind sizes:- Petrol Engines only: . . .	Undersize Journal dia. Crankpin dia.
	0,25 mm 63,24 mm 58,47 mm (0.010 in.) (2,490 in.) (2,302 in.)
	0,50 mm 62,99 mm 58,22 mm (0.020 in.) (2,480 in.) (2,292 in.)
	0,76 mm 62,73 mm 57,96 mm (0.300 in.) (2,470 in.) (2,282 in.)
	1,01 mm 62,48 mm 57,70 mm (0.040 in.) (2,460 in.) (2,272 in.)
Main bearing running clearance—Petrol . .	0,20 mm to 0,072 mm (0.0008 in. to 0.00285 in.)
Main bearing running clearance—Diesel . .	0,20 mm to 0,063 mm (0.0008 in. to 0.0025 in.)
Connecting rod bearing running clearance (Petrol and Diesel)	0,019 mm to 0,068 mm (0.00075 to 0.0027 in.)

CYLINDER PRESSURES – Petrol

Check 12.25.01

Checking

- 1 Run the engine until it attains normal operating temperature.
- 2 Remove the sparking plugs.
- 3 Secure the throttle in the fully open position.
- 4 Check each cylinder in turn as follows:
- 5 Insert a suitable pressure gauge into the sparking plug hole.
- 6 Crank the engine with the starter motor for several revolutions and note the highest pressure reading obtainable.
- 7 If the pressure is appreciably less than the correct figure, the piston rings or valves may be faulty.
- 8 Low pressure in adjoining cylinders may be due to a faulty cylinder head gasket.

Compression ratio:

Compression pressure

Cranking speed

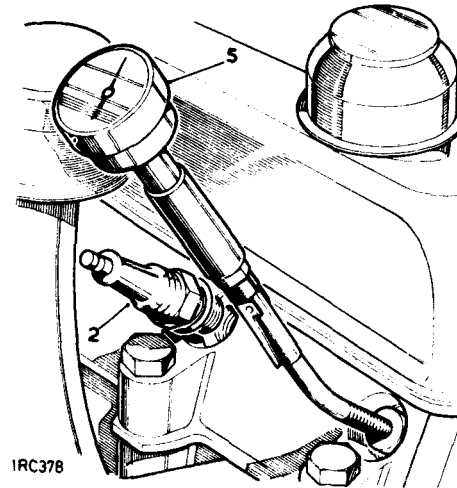

7.0 : 1	8.0 : 1
10,2 kgf/cm ²	11,2 kgf/cm ²
(145 lbf/in ²)	(160 lbf/in ²)
300 rev/min	300 rev/min

CYLINDER PRESSURES— Diesel

Check 12.25.01

See page 12—23.

CYLINDER SIDE COVERS - Petrol

Remove and refit

- Front side cover 1 to 6,
10 and 11 12.25.14
- Rear side cover 1, 2, 7 to 10 and
12 to 14 12.25.16

Removing

- 1 Remove the bonnet. 76.16.01.
- 2 Remove the air cleaner. 19.10.04.
- 3 Release the oil filler pipe bracket from the cylinder block.
- 4 Remove the front side cover complete with oil filler pipe.
- 5 Withdraw the baffle.
- 6 Withdraw the joint washers.
- 7 Disconnect the fuel pipes at the fuel pump.
- 9 Withdraw the joint washer.

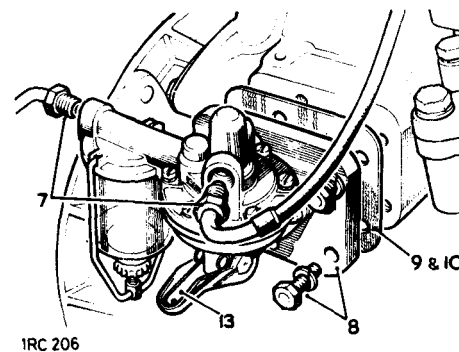

Refitting

- 10 Smear both sides of a new joint washer with general purpose grease.
- 11 Reverse 1 to 6. When fitting front the side cover bolts first engage the tapping nearest to the oil filter pipe.
- 12 Reverse 7 to 9.
- 13 Prime the fuel pump by operating the hand prime lever until no resistance is felt.
- 14 Reverse 1 and 2.

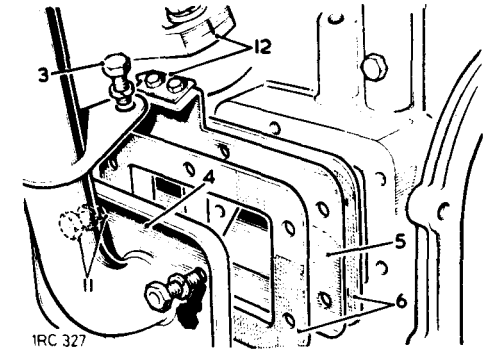
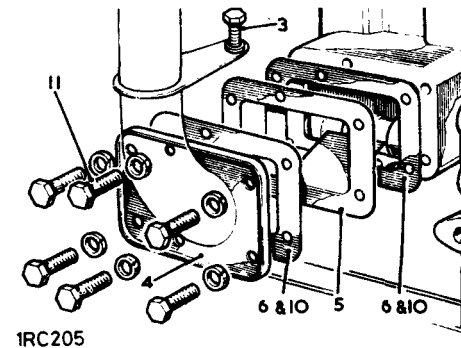

- 7 Disconnect the fuel pipes at the fuel pump.
- 8 Remove the rear side cover complete with the fuel pump.
- 9 Withdraw the joint washer.

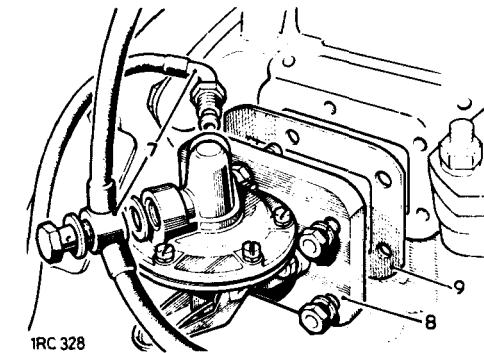

CYLINDER SIDE COVERS – Diesel

Remove and refit

- Front side cover 1 to 6 and 10 to 12 12.25.14
- Rear side cover 1,2, 7 to 10 and
13 to 15 12.25.16

Removing

- 1 Remove the bonnet. 76.16.01.
- 2 Remove the air cleaner. 19.10.04.
- 3 Release the oil filter pipe bracket from the cylinder block.
- 4 Remove the front side cover complete with oil filler pipe.
- 5 Withdraw the baffle.
- 6 Withdraw the joint washers.

Refitting

- 10 Smear both sides of a new joint washer with general purpose grease.
- 11 Reverse 1 to 6. When fitting the side cover bolts, first engage the tapping nearest to the oil filler pipe.
- 12 Align the timing pointer with the timing mark scribed on the flange of the fuel distributor pump.
- 13 Reverse 7 to 9.
- 14 Prime the fuel system. 19.50.01.
- 15 Reverse 1 and 2.

CYLINDER HEAD – Petrol

Remove and refit

12.29.10

Removing

- 1 Remove the bonnet. 76.16.01.
- 2 Remove the air cleaner. 19.10.04.
- 3 Disconnect the battery earth lead.
- 4 Drain the cooling system.
- 5 Disconnect the vacuum pipe at the distributor.
- 6 Disconnect the distributor leads at the ignition coil.
- 7 Disconnect the distributor leads from the sparking plugs.
- 8 Remove the sparking plugs.
- 9 Remove the fan cowl shroud.
- 10 Disconnect the oil gallery pipe.
- 11 Disconnect the coolant by-pass hose.
- 12 Disconnect the coolant hoses from the thermostat housing.
- 13 Disconnect the carburettor linkage at the ball joint.
- 14 Disconnect the cold start cable at the carburettor.
- 15 Disconnect the fuel inlet pipe at the carburettor and release the pipe clip at the cylinder head.
- 16 Remove the heat shield from the manifold.
- 17 Disconnect the exhaust pipe at the manifold.
- 18 Remove the valve gear. 12.29.34.
- 19 Slacken evenly and remove the remaining cylinder head fixings.
- 20 Lift off the cylinder head.
- 21 Withdraw the gasket.

Refitting

CAUTION: If a non-retorque fabric type cylinder head gasket is being used it must be fitted dry, without grease or any sealing compound.

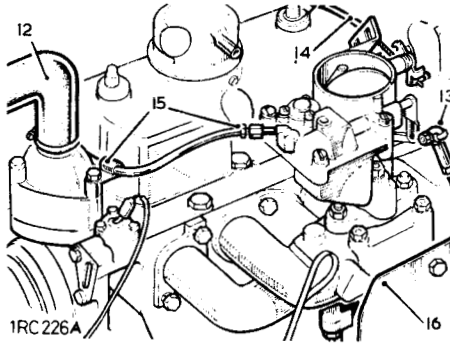
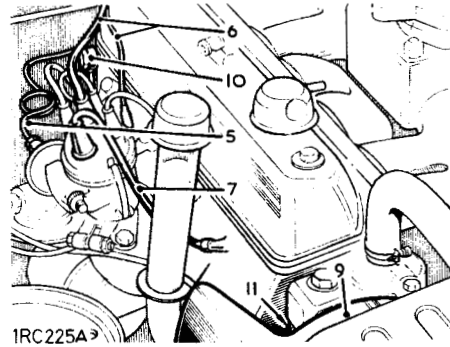

- 22 If a copper-asbestos gasket is being used, smear clean engine oil on the cylinder block and cylinder head gasket joint faces.
- 23 Position the gasket on the cylinder block with the lettering 'PETROL' uppermost.

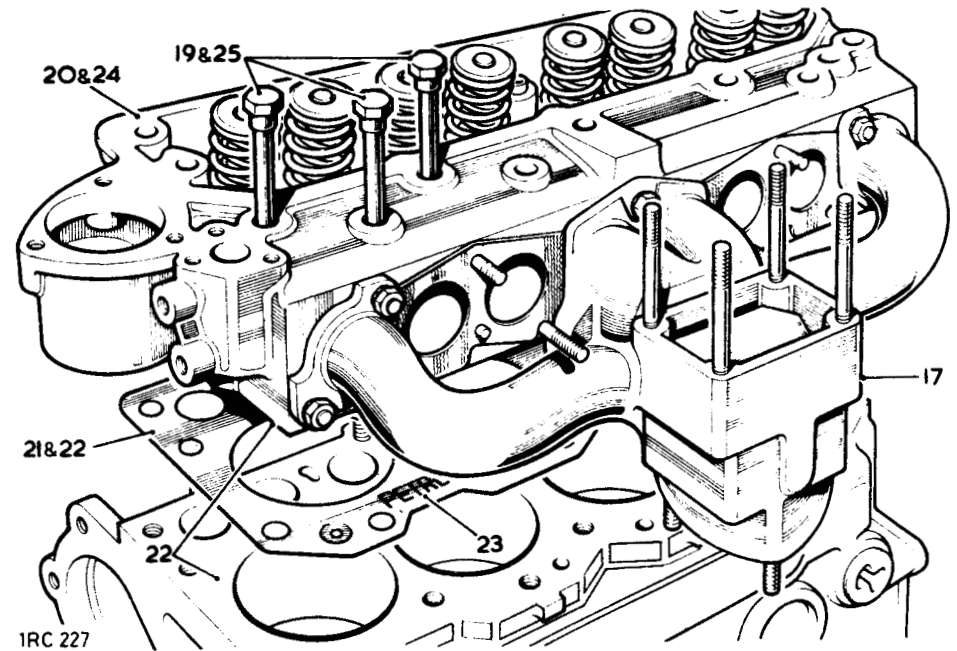

- 24 Place the cylinder head in position.
- 25 Engage all the cylinder head fixing bolts except those also used to secure the rocker shaft assembly.
NOTE: Plain washers are fitted between the cylinder head bolts and the cylinder head on later engines.
- 26 Place the push rods into position and ensure that they bottom correctly into the spherical seats in the tappet slides.
- 27 Fit the rocker shaft assembly and engage the fixings.
- 28 Secure the cylinder head and rocker shaft fixings in the sequence illustrated. Torque: 1/2 in. UNF bolts 8,9 kgf. m (65 lbf. ft.). 5/16 in. UNF bolts 2,4 kgf. m (18 lbf. ft.).

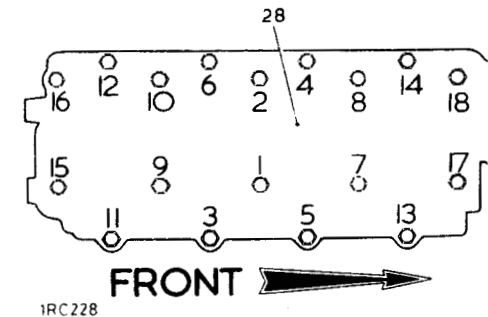

- 29 Set the tappet clearances to 0,25 mm (0.010 in.) for all valves as follows:
Set No. 1 tappet with No. 8 valve fully open.
Set No. 3 tappet with No. 6 valve fully open.
Set No. 5 tappet with No. 4 valve fully open.
Set No. 2 tappet with No. 7 valve fully open.
Set No. 8 tappet with No. 1 valve fully open.
Set No. 6 tappet with No. 3 valve fully open.
Set No. 4 tappet with No. 5 valve fully open.
Set No. 7 tappet with No. 2 valve fully open.
- 30 Recheck the tappet clearances with the locknuts tightened, and readjust if necessary.
- 31 Place the joint washer for the engine top cover in position.
- 32 Fit the engine top cover.
- 33 Reverse 1 to 17.
- 34 After the initial engine run, that is with the engine at normal running temperature, check the cylinder head fixings to the correct torque load with the sparking plugs removed.

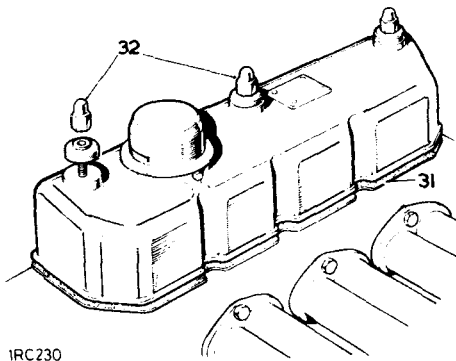
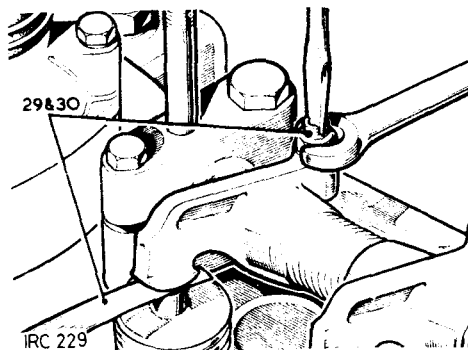

CYLINDER HEAD – Diesel

Remove and refit

12.29.10

Service tool: 606445 Spanner for cylinder head bolts

Removing

- 1 Remove the bonnet. 76.16.01.
- 2 Remove the air cleaner. 19.10.04.
- 3 Disconnect the battery earth lead.
- 4 Drain the cooling system.
- 5 Disconnect the fuel spill pipes at the injector end.
- 6 Disconnect the oil gallery pipe.
- 7 Disconnect the electrical feed to the heater plugs.
- 8 Disconnect the electrical lead from the water temperature transmitter.
- 9 Disconnect the breather hose from the engine top cover.
- 10 If a brake servo unit is fitted, disconnect the vacuum pipe and the butterfly control rod from the induction manifold.
- 11 Disconnect the exhaust pipe at the manifold.

continued

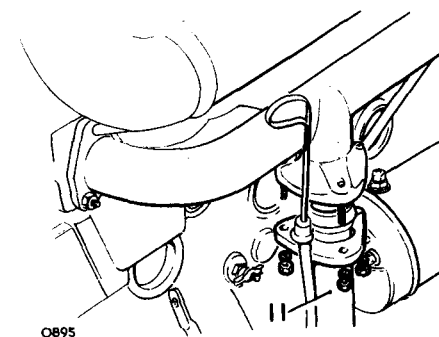
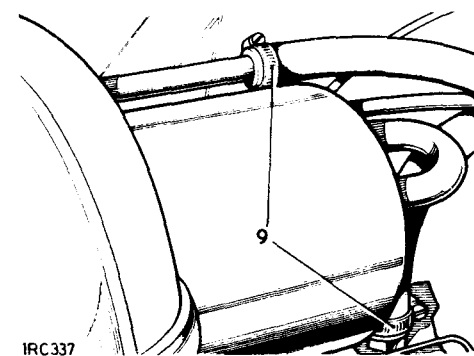
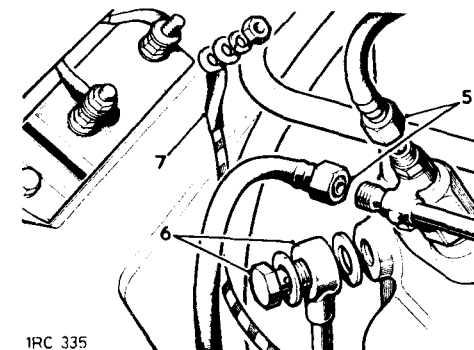

- 12 Disconnect the heater hoses if fitted.
- 13 Disconnect the coolant hose from the thermostat housing.
- 14 Disconnect the coolant by-pass hose.

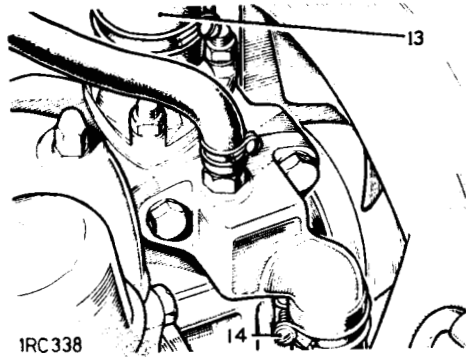

- 15 Slacken the fuel injector feed pipes at the distributor pump and disconnect them from the injectors.

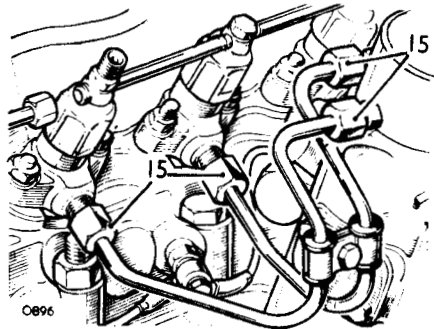

- 16 Remove the valve gear. 12.29.34.
- 17 Slacken evenly and remove the remaining cylinder head fixings.
- 18 Lift off the cylinder head.
- 19 Withdraw the gasket.

Refitting

CAUTION: If a non-retorque fabric type cylinder head gasket is being used it must be fitted dry, without grease or any sealing compound.

Refitting

- 20 If a copper-asbestos type gasket is being fitted, thinly coat both sides of the gasket with Hylomar PL 32/M jointing compound.
- 21 Position the gasket on the cylinder block with the lettering 'DIESEL' uppermost.
- 22 Place the cylinder head in position. Engage all the cylinder head fixings except those that also secure the rocker shaft assembly.
- NOTE:** Five main bearing engines and later three main bearing engines have plain washers fitted between the cylinder head bolts and the cylinder head.
- 23 Place the push rods into their original bores and ensure that they bottom correctly into the spherical seats in the tappet slides.
- 24 Fit the rocker shaft assembly and engage the fixings.

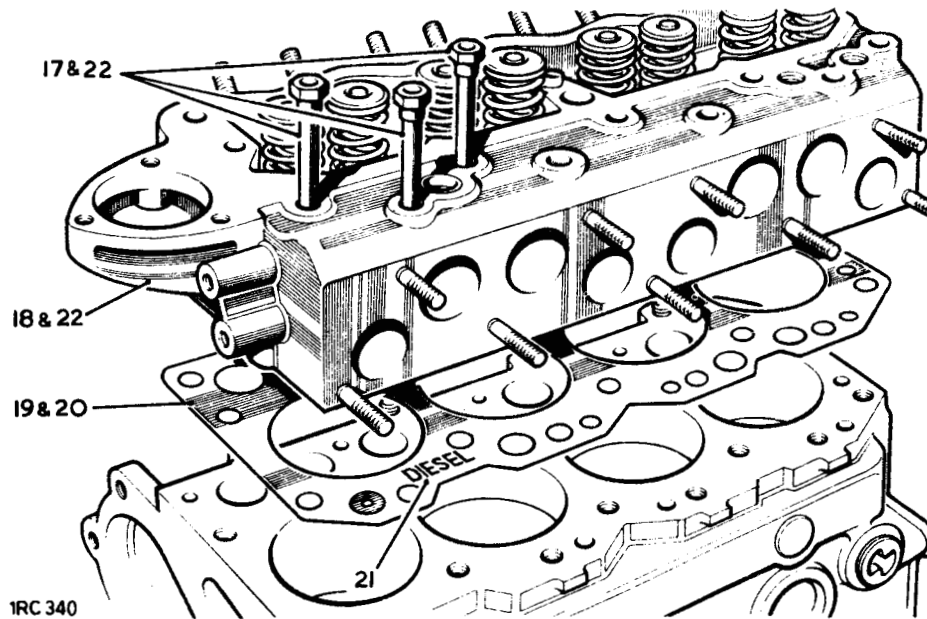

- 25 Secure to 1/2 in. UNF cylinder head fixings. 606445. Torque 12,5 kgf. m (90 lbf. ft.).
- 26 Secure the 5/16 in. UNF rocker shaft fixings. Torque 2,4 kgf. m (18 lbf. ft.).

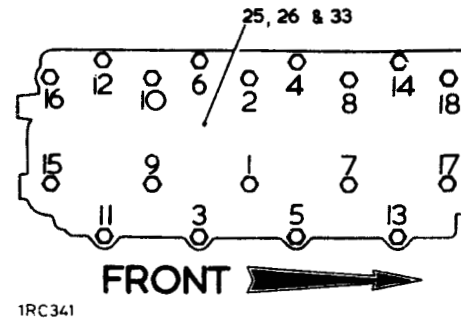

- 27 Set the tappet clearances to 0,25 mm (0.010 in.) for all valves, as follows:
Set No. 1 tappet with No. 8 valve fully open.
Set No. 3 tappet with No. 6 valve fully open.
Set No. 5 tappet with No. 4 valve fully open.
Set No. 2 tappet with No. 7 valve fully open.
Set No. 8 tappet with No. 1 valve fully open.
Set No. 6 tappet with No. 3 valve fully open.
Set No. 4 tappet with No. 5 valve fully open.
Set No. 7 tappet with No. 2 valve fully open.
- 28 Recheck the tappet clearances with the locknuts tightened, and readjust if necessary.

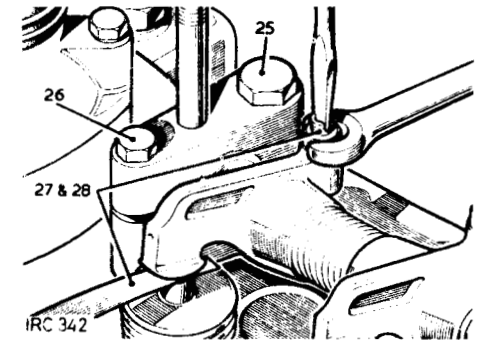

- 29 Place the joint washer for the engine top cover in position.
- 30 Fit the engine top cover.
- 31 Reverse 1 to 15.

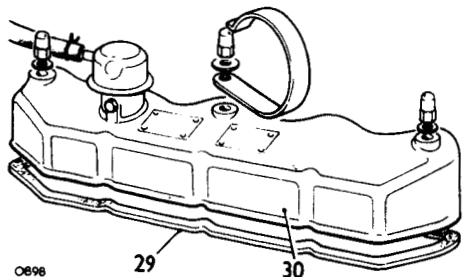

0898

- 32 Start and run the engine until it attains normal operating temperature.
- 33 Remove the engine top cover, and while the engine is hot, check/tighten all the 1/2 in. UNF cylinder head fixings in the order shown. 606445. Torque 12,5 kgf. m (90 lbf. ft.).

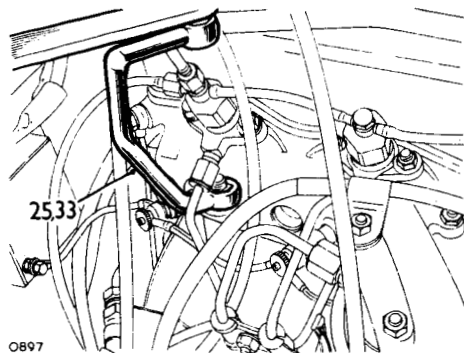

0897

CYLINDER HEAD – Petrol

Overhaul

12.29.18

Service tools: 276102 Valve spring compressor
 274400 Inlet valve guide remover
 274401 Exhaust valve guide remover
 600959 Exhaust valve guide replacer
 601508 Inlet valve guide replacer
 MS627 Inlet valve seat cutter
 MS621 Exhaust valve seat cutter
 MS76 Hand set
 MS150—8 Adjustable pilot
 MS150—8.5 Adjustable pilot

Dismantling

- 1 Remove the cylinder head. 12.29.10.
- 2 Remove the induction and exhaust manifold assembly. 30.15.01.
- 3 Remove the thermostat housing complete.
- 4 Remove the valve assemblies and retain the components in related sets. Compressor 276102.

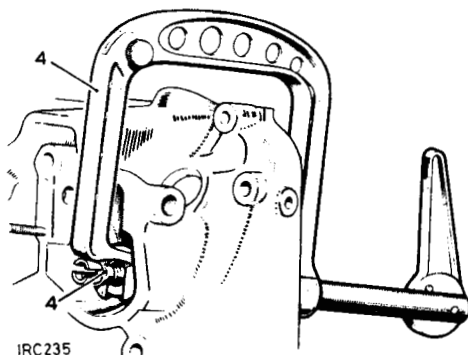

IRC235

- 5 Withdraw the oil seals from the valve guides.
- 6 Clean the combustion chambers and piston crowns with a soft wire brush.

- 7 Clean the valves.
- 8 Clean the valve guide bores.

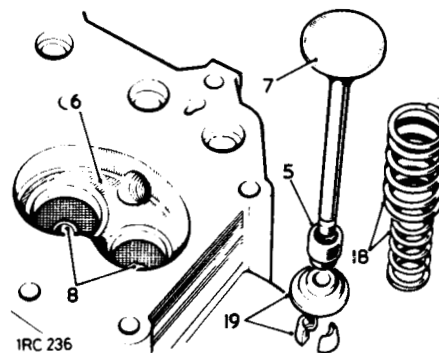

IRC 236

- 9 Regrind or fit new valves as necessary.
- 10 The correct angle for the inlet valve face is $30^\circ - \frac{1}{4}$.
- 11 The correct angle for the exhaust valve face is $45^\circ - \frac{1}{4}$.
- 12 The correct angle for the inlet valve seat is $30^\circ + \frac{1}{4}$.
- 13 The correct angle for the exhaust valve seat is $45^\circ + \frac{1}{4}$.

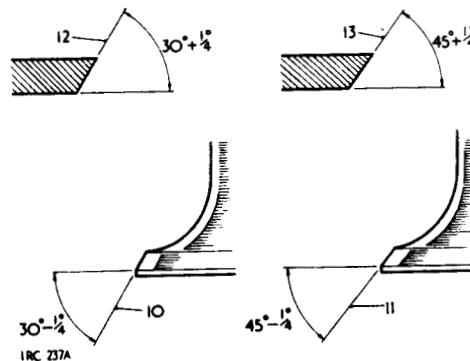

IRC 237A

- 14 Check the valve guides and fit replacements as necessary. 15 to 17.
- 15 Drive out the old guides from the combustion chamber side. 274400 and 274401.

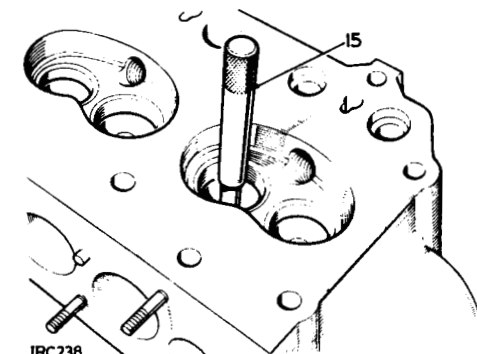

IRC238

- 16 Lubricate the new valve guides and drive them into position. 600959 and 601508.

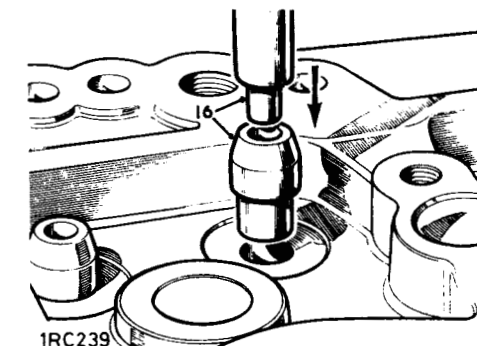

IRC239

- 17 Check and if necessary, reface the valves and seats, as previously described.
- 18 Inspect the valve springs which are provided as paired assemblies. The springs must be an interference fit with each other.
- 19 Inspect the valve split cones and valve spring caps for general condition.
- 20 Inspect the cylinder head for general condition and for damage to threads.

continued

Assembling

- 21 Fit the oil seals, fitted with springs, to the inlet valve guides.
- 22 Fit the oil seals, with external projections, to the exhaust valve guides.
- 23 Lubricate the valve stems and guides with engine oil and fit each valve as follows:
- 24 Insert the valve into its respective guide.
- 25 Place the valve springs in position.
- 26 Locate the cap on the springs.
- 27 Compress the springs and fit the valve collets. 276102.
- 28 Reverse 1 to 3.
- 29 After the initial engine run, that is with the engine at normal running temperature, check the cylinder head fixings to the correct torque load with the sparking plugs removed. Torque 1/2 UNF bolts 8,9 kgf. m (65 lbf. ft.). 5/16 UNF bolts 2,4 kgf. m (18 lbf. ft.).

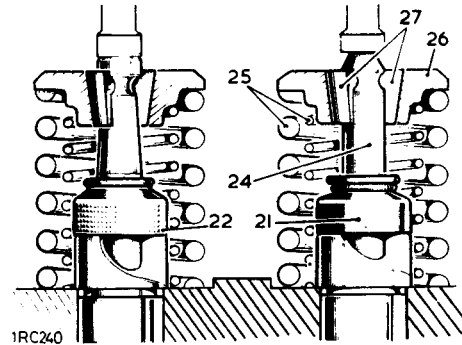
**DATA****Cylinder Head**

Inlet valve seat angle	$30^{\circ} + \frac{1}{4}^{\circ}$
Exhaust valve seat angle	$45^{\circ} + \frac{1}{4}^{\circ}$

Valves

Inlet valve	7,88 mm to 7,90 mm (0.3107 in. to 0.3112 in.)
Diameter of stem	
Face angle	$30^{\circ} - \frac{1}{4}^{\circ}$
Exhaust valve	
Diameter of stem	8,65 mm to 8,67 mm (0.3410 in. to 0.3415 in.)
Face angle	$45^{\circ} - \frac{1}{4}^{\circ}$

Valve guides

Inlet bore size, after fitting	7,93 mm to 7,97 mm (0.3125 in. to 0.3140 in.)
Exhaust bore size after fitting	8,73 mm to 8,77 mm (0.3435 in. to 0.3450 in.)

Valve Springs

Inner	
Length, free	42,67 mm (1.680 in.)
Length, under 8,0 kg (17.7 lb) load	37,13 mm (1.462 in.)

Outer

Length, free	46,28 mm (1.822 in.)
Length, under 21 kg. (46 lb) load	40,30 mm (1.587 in.)

CYLINDER HEAD – Diesel**Overhaul**

12.29.18

Service tools: 276102 Valve spring compressor
 274400 Inlet valve guide remover
 274401 Exhaust valve guide remover
 600959 Exhaust valve guide replacer
 601508 Inlet valve guide replacer
 530625 Exhaust seat insert replacer
 MS 621 Inlet and exhaust valve seat cutter
 MS 76 Hand set
 MS 150—8 Adjustable pilot
 MS 150—8.5 Adjustable pilot

Dismantling

- 1 Remove the cylinder head. 12.29.10.
- 2 Remove the induction and exhaust manifold assembly. 30.15.01.
- 3 Remove the injectors. 19.60.01.
- 4 Remove the thermostat housing complete.
- 5 Remove the valve assemblies and retain the components in related sets. Compressor 276102.
- 6 Withdraw the oil seals from the valve guides.
- 7 Clean the combustion chambers and piston crowns with a soft wire brush.
- 8 Clean the valves.
- 9 Clean the valve guide bores.
- 10 Re grind or fit new valves as necessary.
- 11 The correct angle for inlet and exhaust valve faces is $45^{\circ} - \frac{1}{4}^{\circ}$.
- 12 The correct angle for the inlet and exhaust valve seats is $45^{\circ} + \frac{1}{4}^{\circ}$.
- 13 Check the valve guides and fit replacements as necessary. 14 to 16.

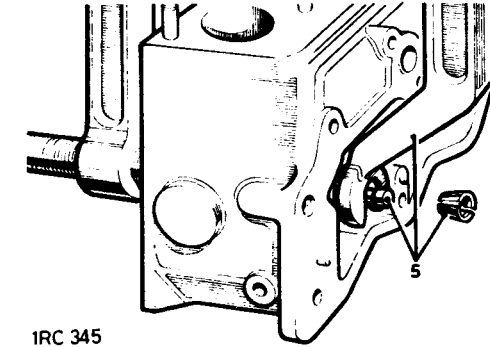

1RC 345

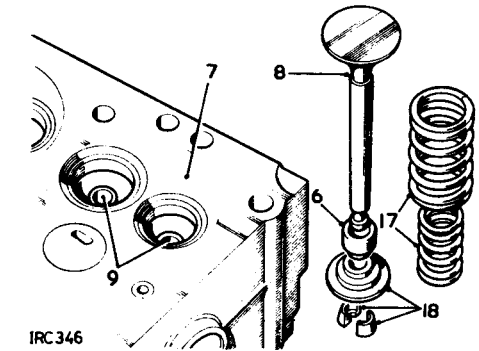

1RC 346

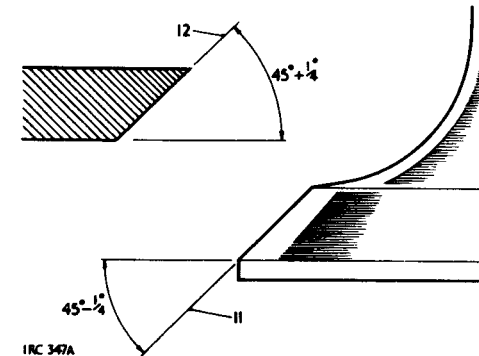

1RC 347A

- 14 Drive out the old guides from the combustion chamber side. 274400 and 274401.

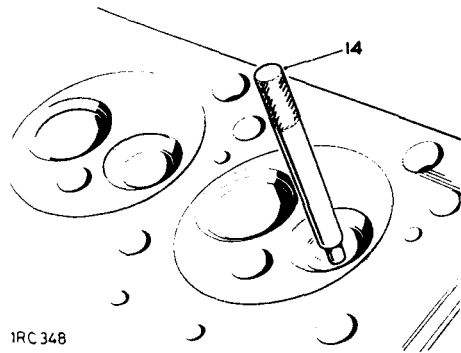

IRC 348

- 15 Lubricate the new valve guides and drive them into position. 600959 and 601508.

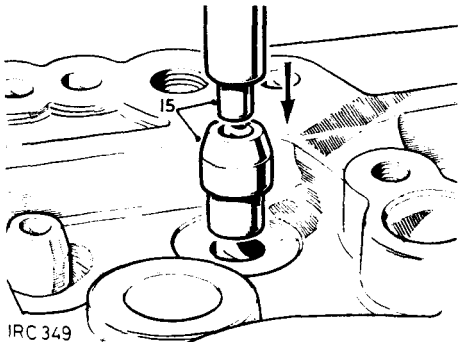

IRC 349

- 16 Check and if necessary, reface the valves and seats, as previously described.
- 17 Inspect the valve springs which are provided as paired assemblies. The springs must be an interference fit with each other.
- 18 Inspect the valve collets and valve springs caps for general condition.
- 19 Check the exhaust valve seats and fit replacements as necessary.

- 20 Remove the valve guides from the applicable exhaust ports.
- 21 Remove the old seat inserts by grinding them away until they are thin enough to be cracked and prised out.
- 22 Place the new seat insert in position.
- 23 Locate the replacer tool 530625, onto the seat insert.
- 24 Using a suitable nut and bolt, pull the insert into the recess in the cylinder head.

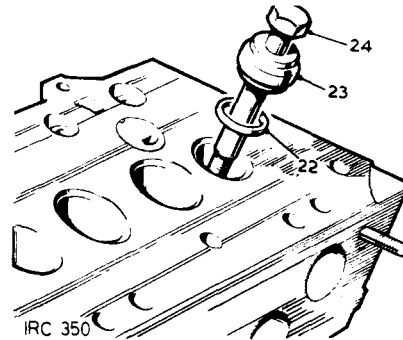

IRC 350

- 25 Fit the valve guides as previously detailed.
- 26 Cut the valve seats to $45^\circ + \frac{1}{4}^\circ$.
- 27 Check the push rod tubes and seals and fit replacements as necessary. 28 to 32.
- 28 Drive out the old push rod tubes from valve gear side. Using a suitable drift.

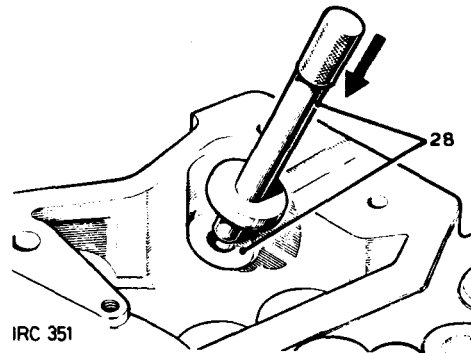

IRC 351

- 29 Fit new sealing rings to new push rod tubes and smear them with MS4 silicone grease.

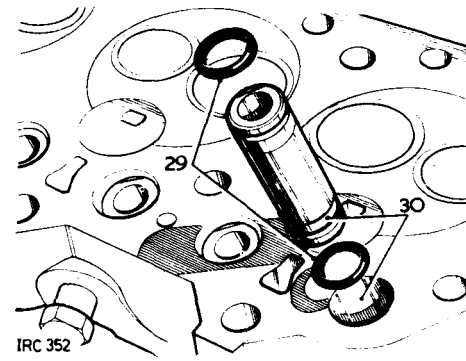

IRC 352

- 30 Insert the new tubes, chamfered end first, from the combustion chamber side.
- 31 Align the flat on the push rod tube at right angles to an imaginary line between the centre of the push rod tube and the centre of the hot plug.

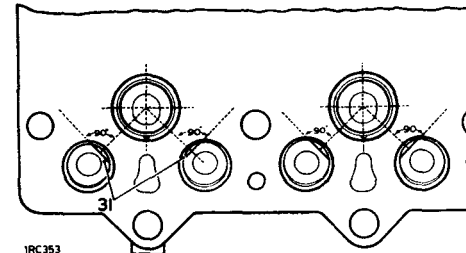

IRC 353

- 32 Press the push rod tubes into position ensuring that the alignment is maintained and that the chamfers on the tubes and in the cylinder head are fully engaged.

Hot plugs (combustion chamber) and injector shrouds

When carrying out normal top overhaul work on the cylinder it is not necessary to remove either the injector shrouds or the hot plugs.

Small surface cracks in the hot plug, extending from the opening to approximately 8,0 mm (0.312 in.) in length can be ignored. However if any severe cracks appear on the face of the hot plug, before attempting to remove it, closely inspect the cylinder head for signs of cracks, particularly between the inlet and exhaust valve seats. Such cracking indicates that the engine has overheated, usually through lack of coolant, and the cylinder head should be scrapped.

continued

- 33 To remove a hot plug, insert a thin soft metal drift through the injector shroud throat and tap the hot plug from the inside. Once removed the hot plug is scrap.
- 34 If the injector shroud is damaged, drift the shroud out towards the injector bore.
- 35 Thoroughly clean out the combustion chamber. The hole in the side of the injector shroud is for manufacturing purposes only but at the same time can be used as a guide when refitting the shroud.
- 36 Smear a little oil on the shroud and insert into the cylinder head with the hole pointing towards the centre of the cylinder head, and drift into position. 274399.
- 37 Fit the hot plugs by tapping with a hide-faced mallet.
- 38 When fitted, the hot plugs must be checked with a dial test indicator to ensure that they do not protrude above the level of the cylinder head face more than 0,025 mm (0.001 in.) and are not recessed below the level of the cylinder head face more than 0,05 mm (0.002 in.).

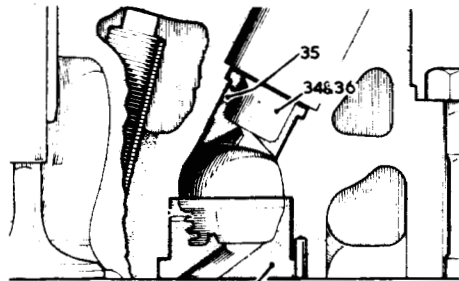

33, 37 & 38

1RC354

NOTE: If the hot plugs are loose in the cylinder head they may be retained with a little grease.

Assembling

- 39 Fit the oil seals, fitted with springs, to the inlet valve guides.
- 40 Fit the oil seals, with external projectors, to the exhaust valve guides.
- 41 Lubricate the valve stems and guides with engine oil and fit each valve as follows:
- 42 Insert the valve into its respective guide.
- 43 Place the valve springs in position.
- 44 Locate the cap on the springs.
- 45 Compress the springs and fit the valve collets. 276102.

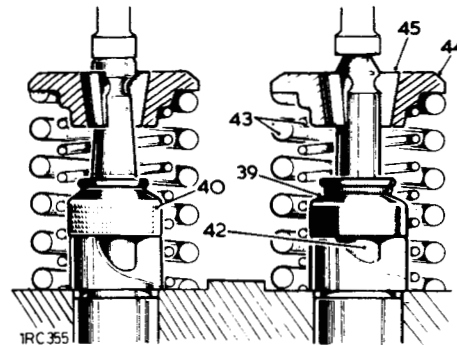

- 46 Reverse 1 to 4.
- 47 After the initial engine run, that is with the engine at normal running temperature, check the cylinder head fixings to the correct torque load. 606445. Torque: 1/2 in. UNF fixings 12,5 kgf. m (90 lbf. ft.). 5/16 in. UNF fixings 2,4 kgf. m (18.lbf. ft.).

DATA

Cylinder Head

Inlet valve seat angle	45° + ¼°
Exhaust valve seat angle	45° + ¼°

Valves

Inlet valve	
Diameter of stem	7,88 mm to 7,90 mm (0.3107 in. to 0.3112 in.)
Face angle	45° - ¼°
Exhaust valve	
Diameter of stem	8,65 mm to 8,67 mm (0.3410 in. to 0.3415 in.)
Face angle	45° - ¼°

Valve guides

Inlet guide bore size, after fitting	7,93 mm to 7,97 mm (0.3125 in. to 0.3140 in.)
Exhaust guide bore, after fitting	8,73 mm to 8,77 m (0.3435 in. to 0.3450 in.)

Valve springs

Inner	
Length, free	42,67 mm (1.680 in.)
Length, under 8,0 kg (17.7 lb.) load	37,13 mm (1.462 in.)
Outer	
Length, free	46,28 mm (1.822 in.)
Length, under 21 kg (46 lb) load	40,30 mm (1.587 in.)

VALVE GEAR – Petrol

Remove and refit

12.29.34

Removing

- 1 Remove the bonnet. 76.16.01.
- 2 Remove the air cleaner. 19.10.04.
- 3 Remove the engine top cover.
- 4 Slacken locknuts and turn tappet adjusting screws to disengage from push rods.
- 5 Remove fixings from rocker shaft support brackets. Do not remove shaft assembly at this stage.
- 6 Withdraw the rocker shaft assembly complete, using the engine top cover secured inverted to the rocker bracket studs to retain the assembly.
- 7 Withdraw the tappet push rods and retain them in numbered sequence related to the tappet served.

Refitting

- 8 Fit the tappet push rods to their original bores. Ensure that the bottom end of the push rods locate in the spherical tappet seats.
- 9 Refit the rocker shaft assembly, located by spigots. Torque: 1/2 in. UNF bolts: 8,9 kgf. m (65 lbf. ft.). 5/16 in. UNF bolts: 2,4 kgf. m (18 lbf. ft.).

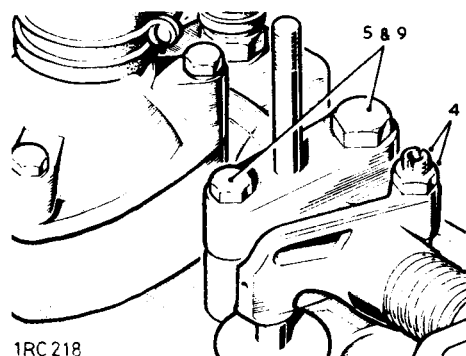

1RC 218

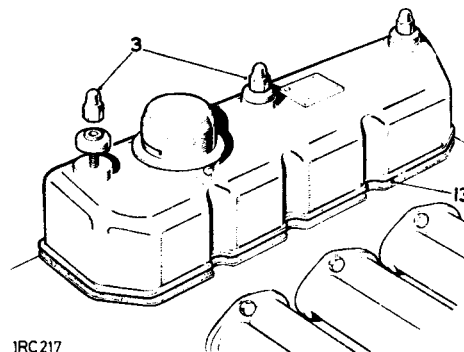

1RC 217

- 10 Check tighten all 1/2 in UNF cylinder head fixings in the order shown. Torque: 8,9 kgf. m (65 lbf. ft.).

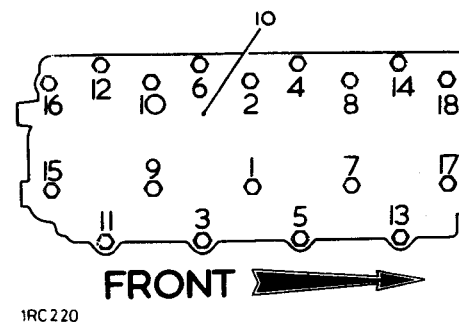

1RC 220

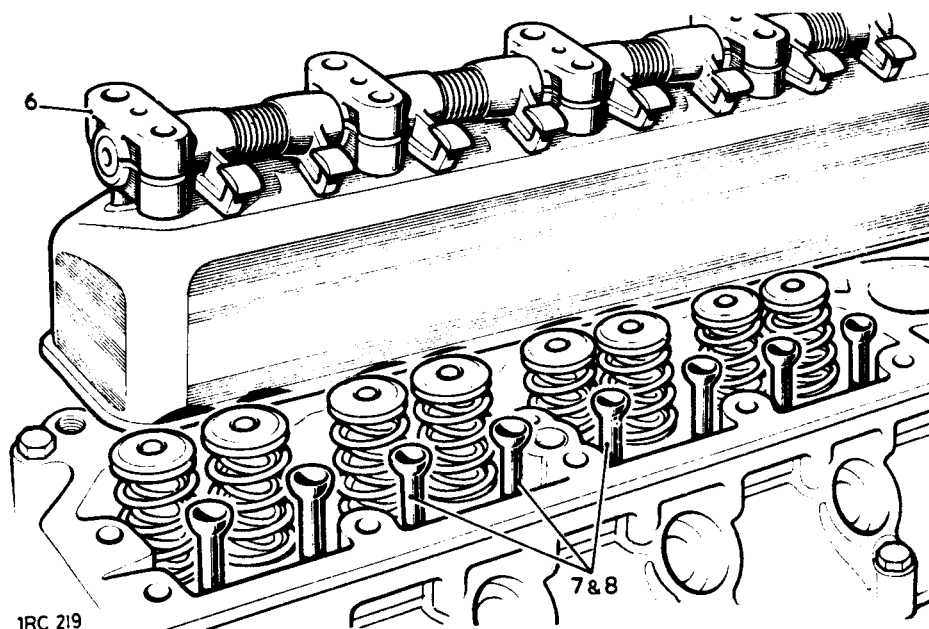

1RC 219

- 11 Set the tappet clearances to 0,25 mm (0.010 in.) for all valves, as follows:
Set No. 1 tappet with No. 8 valve fully open.
Set No. 3 tappet with No. 6 valve fully open.
Set No. 5 tappet with No. 4 valve fully open.
Set No. 2 tappet with No. 7 valve fully open.
Set No. 8 tappet with No. 1 valve fully open.
Set No. 6 tappet with No. 3 valve fully open.
Set No. 4 tappet with No. 5 valve fully open.
Set No. 7 tappet with No. 2 valve fully open.
- 12 Recheck the tappet clearances with the locknuts tightened, and readjust if necessary.
- 13 Place the joint washer for the engine top cover in position.
- 14 Reverse 1 to 3.

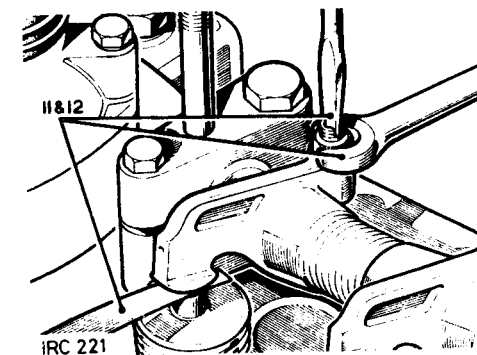

1RC 221

DATA

Tappet clearance 0,25 mm (0.010 in.) inlet and exhaust.

VALVE GEAR – Diesel

Remove and refit

12.29.34

Service tool: 606445 Spanner for cylinder head bolts

Removing

- 1 Remove the bonnet. 76.16.01.
- 2 Remove the air cleaner. 19.10.04.
- 3 Disconnect the breather hose from the engine top cover.
- 4 Remove the engine top cover.

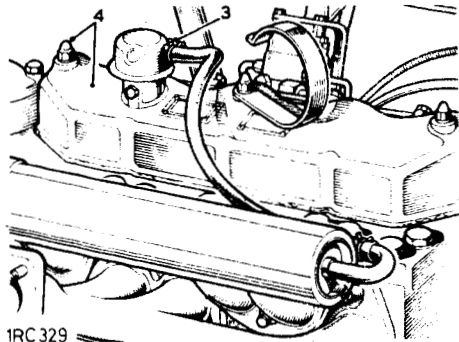

IRC 329

- 5 Slacken locknuts and turn tappet adjusting screws to disengage from push rods.
- 6 Remove fixings from rocker shaft support brackets. Do not remove shaft assembly at this stage.

- 7 Invert the engine top cover and secure it to the studs on the rocker brackets. Withdraw the rocker shaft assembly complete, using the engine top cover to retain the assembly.
- 8 Withdraw the tappet pushrods and retain them in numbered sequence related to the tappet served.

Refitting

- 9 Fit the tappet pushrods to their original bores. Ensure that the bottom end of the push rods locate in the spherical tappet seats.
- 10 Fit the rocker shaft assembly, located by spigots. Torque: 1/2 in. UNF bolts: 12,5 kgf. m (90 lbf. ft.). 5/16 in. UNF bolts: 2,4 kgf. m (19 lbf. ft.).

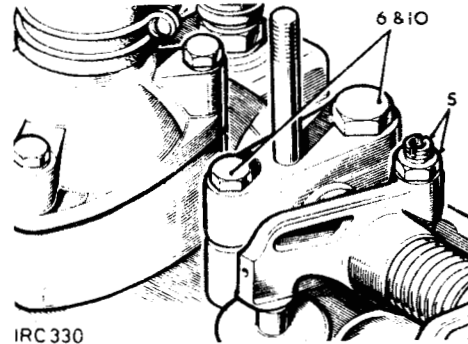

IRC 330

- 11 Check tighten all the 1/2 in. UNF cylinder head fixings in the order shown. 606445. Torque: 12,5 kgf. m (90 lbf. ft.).

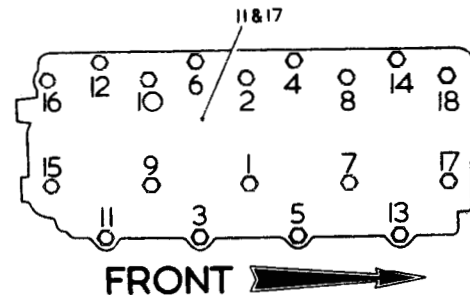

IRC 332

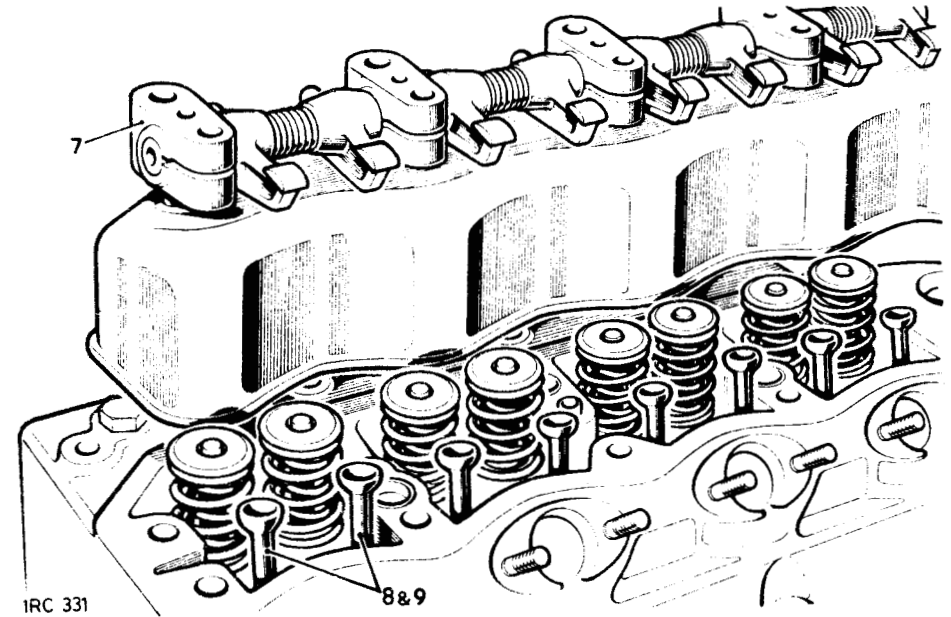

IRC 331

- 12 Set the tappet clearance to 0,25 mm (0.010 in.) for all valves, as follows:
Set No. 1 tappet with No. 8 valve fully open.
Set No. 3 tappet with No. 6 valve fully open.
Set No. 5 tappet with No. 4 valve fully open.
Set No. 2 tappet with No. 7 valve fully open.
Set No. 8 tappet with No. 1 valve fully open.
Set No. 6 tappet with No. 3 valve fully open.
Set No. 4 tappet with No. 5 valve fully open.
Set No. 7 tappet with No. 2 valve fully open.
- 13 Recheck the tappet clearances with the locknuts tightened, and readjust if necessary.

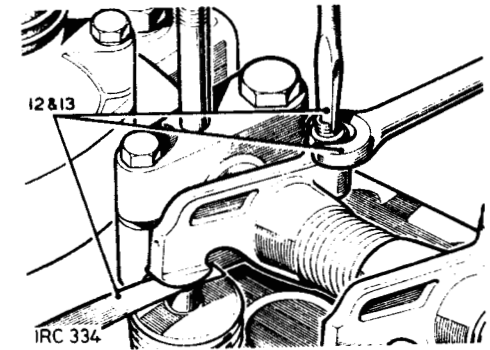

IRC 334

- 14 Place the joint washer for the engine top cover in position.
- 15 Reverse 1 to 4.
- 16 Start and run the engine until it is hot.
- 17 Remove the engine top cover, and while the engine is hot, check/tighten all the 1/2 in. UNF cylinder head fixings in the order shown. 606445. Torque: 12,5 kgf. m (90 lbf. ft.).
- 18 Refit the engine top cover.

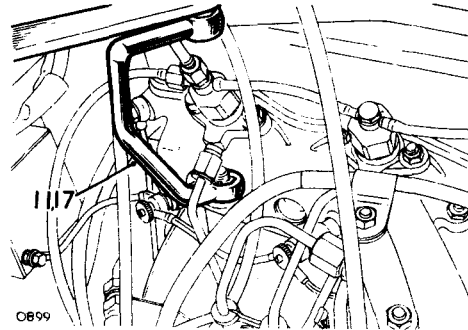

DATA

Tapet clearance

0,25 mm (0.010 in.) inlet and exhaust.

CYLINDER PRESSURES — Diesel

Check 12.25.01

Checking

- 1 Run the engine until it attains normal running temperature.
- 2 Stop the engine and open the bonnet. Disconnect the inlet pipe from the fuel distribution pump to prevent the engine starting during the following check.
- 3 Remove the injector from the cylinder to be checked. The three remaining injectors must be securely fitted to the cylinder head.
- 4 Secure the manifold butterfly valve (accelerator) in the fully open position.
- 5 Insert a suitable pressure gauge into the injector hole in the cylinder head.
- 6 Crank the engine with the starter motor for several revolutions and note the highest pressure reading obtained. For a cylinder in good condition the pressure should be 31,0 to 33,0 kgf/cm².
- 7 If the pressure is considerably less than the minimum figure, the piston rings or valves may be faulty.

- 8 Refit the injector and repeat the foregoing check on the three remaining cylinders.
- 9 Low pressure in adjoining cylinders may be due to a faulty cylinder head gasket.
- 10 Reconnect the inlet pipe to the fuel distribution pump.

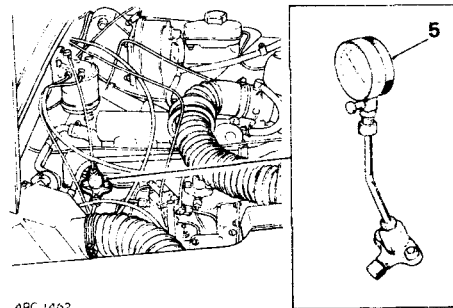

ROCKER SHAFT ASSEMBLY

Overhaul 12.29.55

Dismantling

- 1 Remove the valve gear. 12.29.34.
- 2 Remove the locating screw and washer from the intermediate rocker bracket.
- 3 Withdraw all the components from the rocker shaft.
- 4 Remove the tappet adjustment screws.

Inspecting

- 5 Rocker brackets. Ensure the oil feed holes are clear. Inspect the locating dowel spigots; the spigots must be undamaged to ensure a correct fit on the locating dowels in the cylinder head.
- 6 Valve rockers:
 - a Valve rocker for 2¼ litre Petrol engines.
 - b Valve rocker for 2¼ litre Diesel engines.
 - c Visually inspect the rocker bushes for wear. If necessary, press replacement bushes into the rockers and ream to 13,5 mm + 0,02 mm (0.530 in. + 0.001 in.). The oil holes in the rocker bushes are pre-drilled and must be aligned with the oil holes in the valve rocker when assembled.
- 7 Check that all oil passage drillings are clear.
- 8 Tappet adjusting screws and locknuts. Examine threads for damage. Check that the oil relief drilling is clear.
- 9 Inspect the rocker shaft for wear and scores; check that the oil feed holes are clear.
- 10 Examine the rocker shaft springs, spacing washers and the locating screw for soundness and general condition.
- 11 Fit an intermediate rocker bracket to the rocker shaft and engage the locating screw through the bracket and into the larger hole in the shaft.

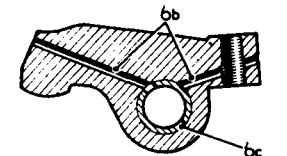
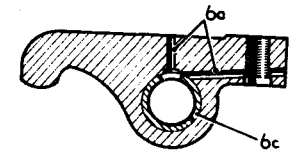
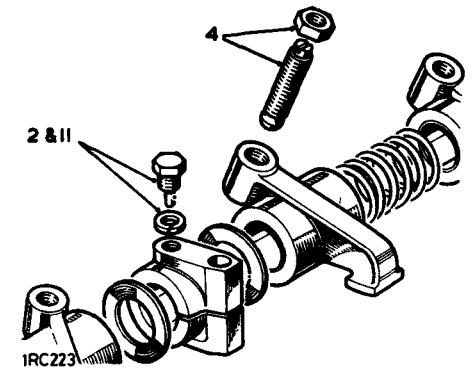

2RC 172

continued

- 12 Petrol engines – Assemble the components to the rocker shaft as illustrated and note the assembled position of the spacing washers and the handed valve rockers.

- 13 Diesel engines – Assemble the components to the rocker shaft as illustrated and note the assembled position of the spacing washers and the handed valve rockers.
 14 Refit the tappet adjustment screws.
 15 Refit the valve gear. 12.29.34.

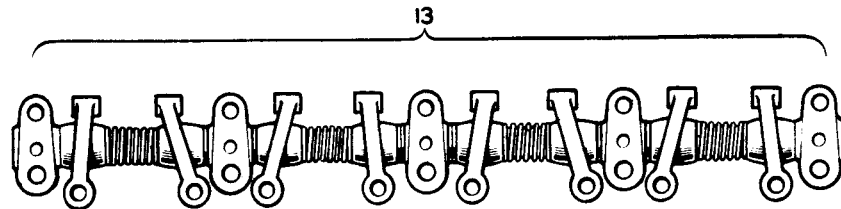
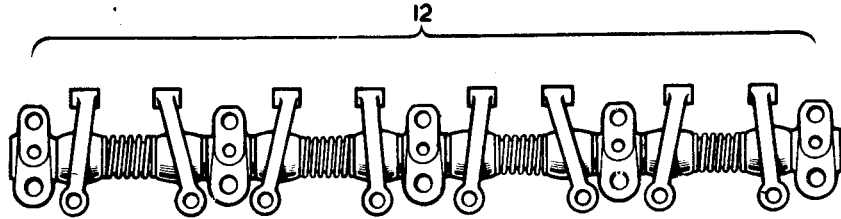

1RC 224

DATA

Rockers

Bush internal diameter, reamed in position.....

13,40 mm to 13,42 mm (0.530 in. to 0.531 in.)

Shaft clearance in rocker bush:

Petrol engines

0,013 mm to 0,038 mm (0.0005 in. to 0.0015 in.)

Diesel engines

0,013 mm to 0,062 mm (0.0005 in. to 0.0025 in.)

TAPPETS

Remove and refit

12.29.57

Service tool: 530101 Tappet Guide remover

Removing

- 1 Remove the bonnet. 76.16.01.
- 2 Remove the air cleaner. 19.10.04.
- 3 Disconnect the battery earth lead.
- 4 Remove the valve gear. 12.29.34.
- 5 Remove the cylinder head. 12.29.10.
- 6 Remove the tappet guide locating bolts from the right hand side of the cylinder block.

CAUTION: Do not remove the tappet guides before the rollers have been withdrawn, otherwise the rollers may fall behind the camshaft.

- 7 Using long nose pliers or a suitably made wire clip, withdraw the tappet slides and retain in sequence.
- 8 Withdraw the tappet rollers and retain with the related slides.
- 9 Withdraw the tappet guides and retain in sequence, with the other related parts.
- 10 If the guides are difficult to withdraw, use Service Tool 530101.

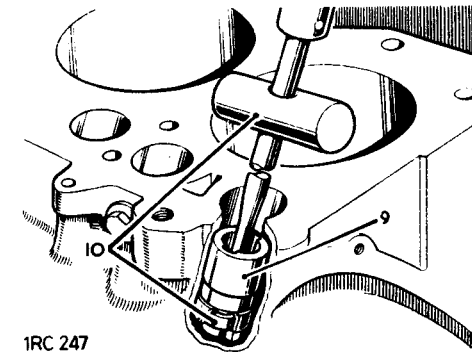

1RC 247

Refitting

- 11 Fit the tappet guides in the sequence removed, aligning the locating holes.
- 12 Engage the locating bolts sufficient to retain the guides.

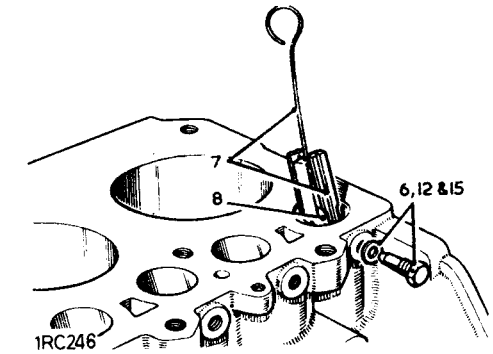

1RC 246

- 13 Fit the tappet rollers with the larger chamfer towards the front of the engine.
- 14 Fit the tappet slides with the marking 'FRONT' towards the front of the engine.
- 15 Tighten the tappet guide locating bolts and secure in pairs by wire-locking.
- 16 Reverse 1 to 5.

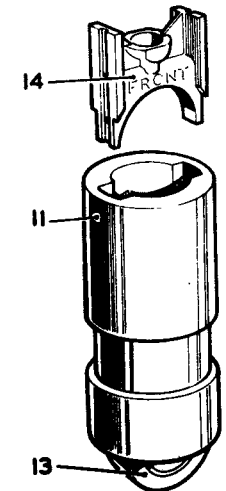

1RC 248

ENGINE ASSEMBLY – Petrol

Remove and refit

12.41.01

Service tool: 600963 Engine sling

Removing

- 1 Remove the bonnet. 76.16.01.
- 2 Remove the air cleaner. 19.10.04.
- 3 Remove the radiator and front panel assembly. 26.40.01.
- 4 Remove the bell housing cover. 76.10.71.
- 5 Disconnect the exhaust pipe at the manifold.

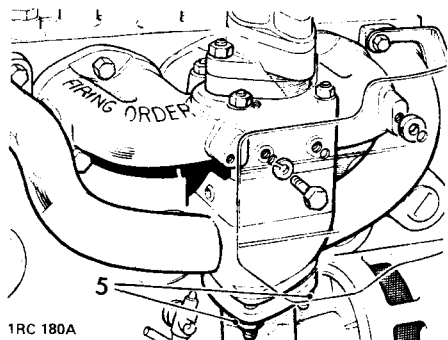

- 6 Disconnect the heater hoses and trunion if fitted.
- 7 Disconnect the carburetter linkage at the ball joint.
- 8 Disconnect the cold start cable at the carburetter.
- 9 Disconnect the distributor leads from the coil.

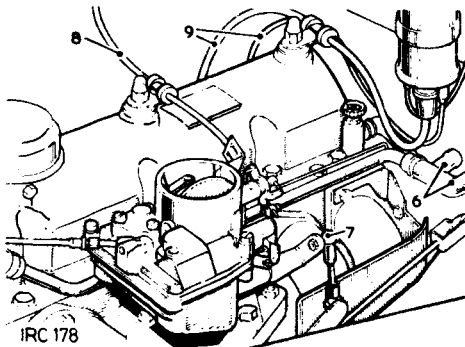

- 10 Disconnect the engine earth cable.

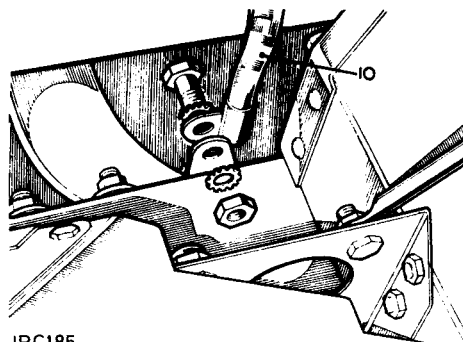

1RC185

- 11 Disconnect the fuel inlet pipe at the fuel pump.
- 12 Release the clutch fluid pipe from the clips at the rear of the engine.
- 13 Disconnect the starter motor leads at the solenoid.
- 14 Disconnect the electrical leads from the alternator.
- 15 Disconnect the engine electrical leads at the multi plug adjacent to the dash.

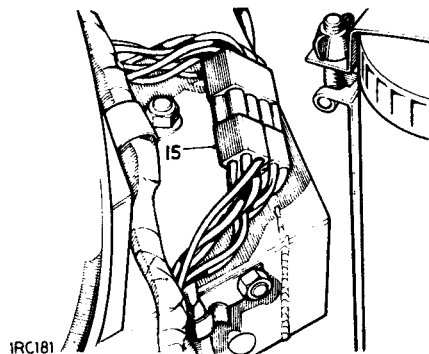

1RC181

- 16 Release the disconnected electrical leads from the retaining clips at the dash panel.
- 17 Release the speedometer drive cable from the clip at the engine.
- 18 Disconnect the vacuum pipe from the distributor where applicable.

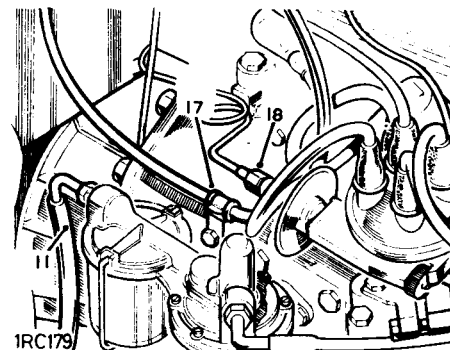

1RC179

- 19 Remove the upper fixings from the engine mounting rubbers.
- 20 Attach a suitable lifting sling and hoist to the engine lifting hooks. 600963.

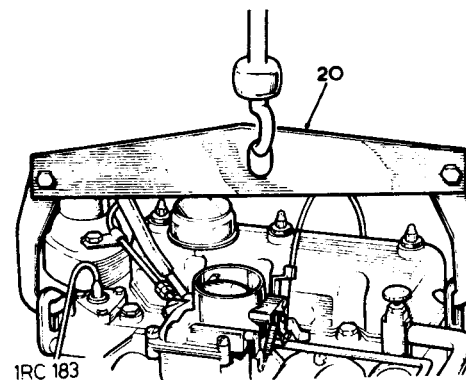

1RC 183

- 21 Remove the bottom fixing from the left hand engine mounting rubber.
- 22 Remove the support bracket fixings from the right hand engine mounting rubber.
- 23 Tension the hoist sufficient to withdraw the engine mounting rubbers, then lower the engine to its original position to maintain alignment with the gearbox.

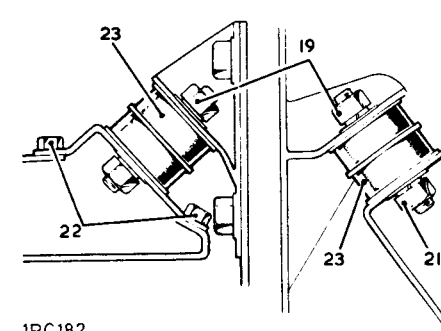

1RC182

- 24 Remove the fixings securing the bell housing to the flywheel housing.
- 25 Move the clutch slave cylinder aside without disconnecting the fluid pipe.

continued

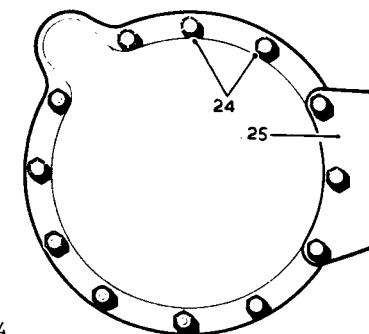

1RC184

- 26 Support the gearbox assembly by inserting a suitable piece of timber 25 mm thick between the gearbox and cross-member.
- 27 Draw the engine forward to release it from the dowelled location to the bell housing, and to clear the primary pinion from the clutch.
- 28 Lift the engine clear.

Refitting

- 29 Attach a suitable lifting sling and hoist to the engine lifting hooks. 600963, and smear the splines of the primary pinion, the clutch centre, and the withdrawal unit abutment faces with Molybdenum disulphide grease such as Rocol MTS 1000.
- 30 Lower the engine into position, locating the primary pinion into the clutch and engage the bell housing dowels.
- 31 Secure the bell housing to the flywheel housing.
- 32 Tension the hoist sufficient to remove the timber support from the gearbox and insert the engine front mounting rubbers.
- 33 Lower the engine and secure the engine mounting upper and lower fixings.
- 34 Remove the engine lifting sling.
- 35 Reverse 1 to 18.
- 36 Check, and if necessary replenish the engine lubricating oil.
- 37 Check, and if necessary replenish the gearbox lubricating oil.
- 38 Start the engine. Check that the oil pressure warning light goes out, and check the cooling system for leaks.
- 39 Check, and if necessary adjust, the engine idle speed.
- 40 Check, and if necessary adjust, the ignition timing.
- 41 When the engine is cold, check the coolant level in the radiator and top up if necessary.

ENGINE ASSEMBLY – Diesel

Remove and refit 12.41.01

Service tool: 600963 Engine sling

Removing

- 1 Remove the bonnet. 76.16.01.
- 2 Disconnect the battery earth lead.
- 3 Remove the air cleaner. 19.10.01.
- 4 Remove the radiator and front panel assembly. 26.40.01.
- 5 Remove the front floor. 76.10.12.
- 6 Disconnect the exhaust pipe at the manifold.

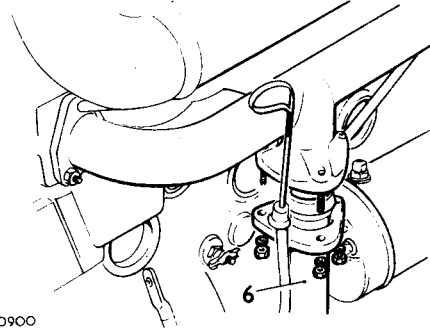

0900

- 7 Disconnect the heater hoses, if fitted.
- 8 Disconnect the starter motor leads.
- 9 Disconnect the alternator leads.

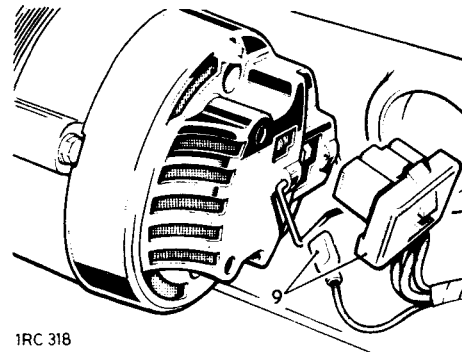

1RC 318

- 10 Disconnect the engine earth cable.
- 11 Disconnect the electrical feed to the heater plugs.

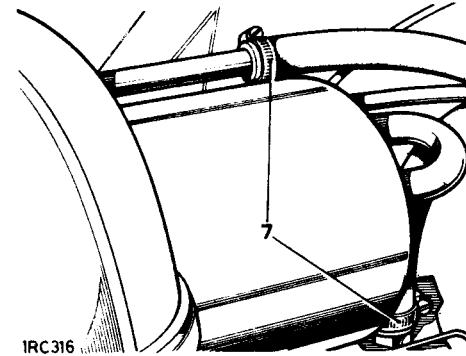

1RC 316

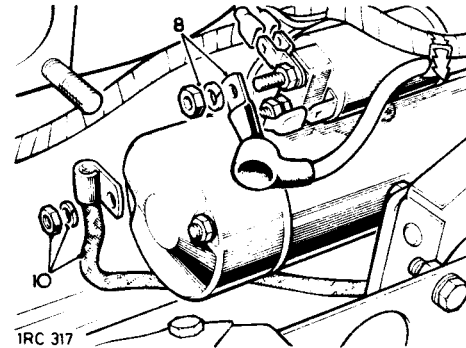

1RC 317

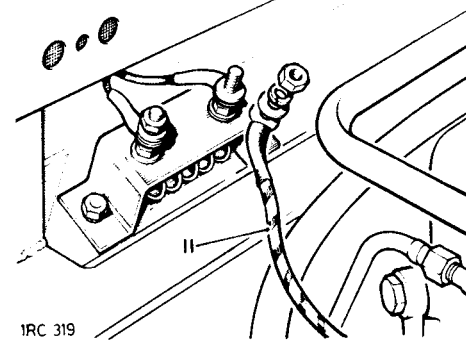

1RC 319

- 12 Disconnect the fuel pipe to the fuel pump.
- 13 Disconnect the fuel inlet pipe from the distributor pump.
- 14 Disconnect the fuel spill pipe at No. 4 injector.

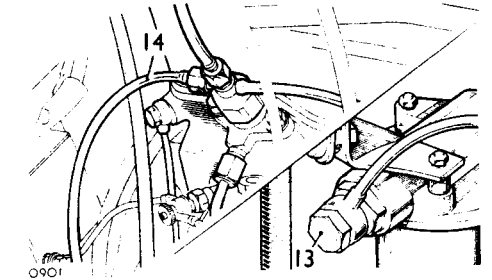

0901

- 15 Disconnect the electrical lead from the oil pressure switch.

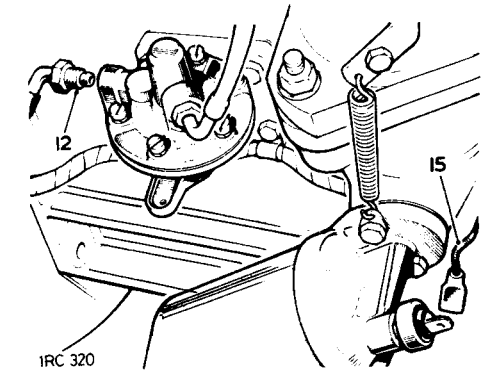

1RC 320

- 16 Disconnect the electrical lead from the water temperature transmitter.
- 17 Disconnect the accelerator linkage at the fuel distributor pump.

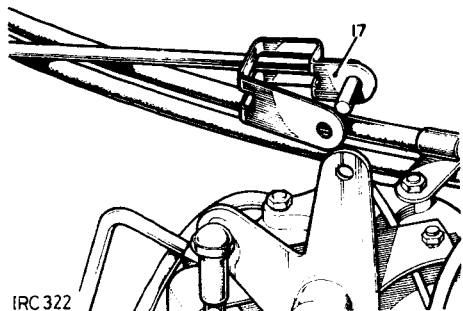

IRC 322

- 18 If a brake servo unit is fitted, disconnect the vacuum pipe and the butterfly control rod from the induction manifold.
- 19 Remove the upper fixings from the engine mounting rubbers.

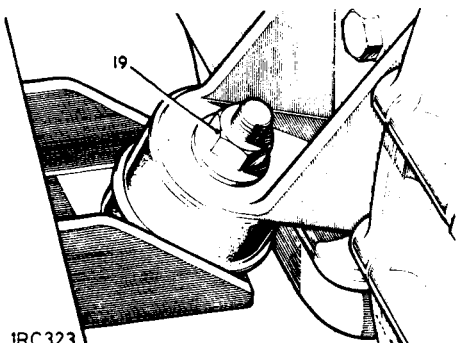

IRC 323

- 20 Attach a suitable lifting sling and hoist to the engine lifting hooks. 600963.
- 21 Remove the bottom fixing from the left hand engine mounting rubber.
- 22 Remove the support bracket fixings from the right hand engine mounting rubber.
- 23 Tension the hoist sufficient to withdraw the engine mounting rubbers, then lower the engine to its original position to maintain alignment with the gearbox.

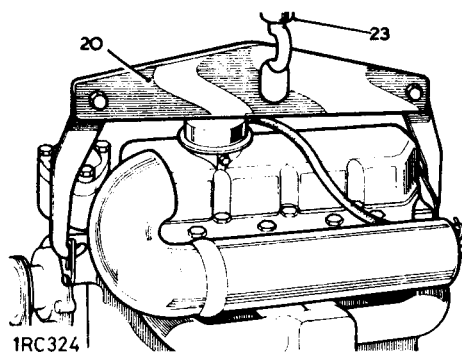

IRC 324

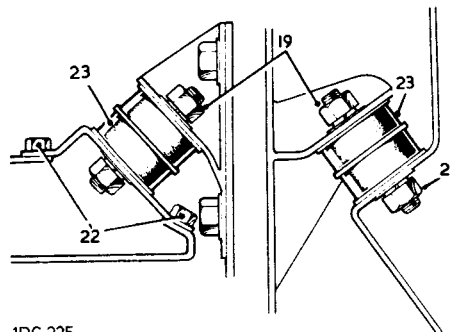

IRC 325

- 24 Remove the fixings securing the bell housing to the flywheel housing.
- 25 Move the clutch slave cylinder aside without disconnecting the fluid pipe.

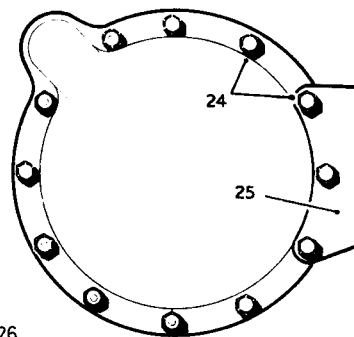

IRC 326

- 26 Support the gearbox assembly by inserting a piece of timber 25 mm thick (1.0 in) between the gearbox and cross-member.
- 27 Draw the engine forward to release it from the dowelled location to the bell housing, and to clear the primary pinion from the clutch.
- 28 Lift the engine clear.

Refitting

- 29 Clean the engine and bell housing mating faces of old sealant. Re-coat the faces with Hylomar PL32 Sealant.
- 30 Attach a suitable lifting sling and hoist to the engine lifting hooks. 600963, and smear the splines of the primary pinion, the clutch centre and the withdrawal unit abutment faces with Molybdenum disulphide grease, such as Rocol MTS 1000.
- 31 Lower the engine into position, locating the primary pinion into the clutch and engage the bell housing dowels.
- 32 Secure the bell housing to the flywheel housing.
- 33 Tension the hoist sufficient to remove the timber support from the gearbox and insert the engine mounting rubbers.
- 34 Lower the engine and secure the engine mounting upper and lower fixing.
- 35 Remove the engine lifting sling.
- 36 Reverse 1 to 18 and prime the fuel system. 19.50.01.
- 37 Check, and if necessary replenish, the engine lubricating oil.
- 38 Check, and if necessary replenish, the gearbox lubricating oil.
- 39 Start the engine. Check that the oil pressure warning light goes out, and check the cooling system for leaks.
- 40 Check, and if necessary adjust, the engine speed settings.
- 41 When the engine is cold, check the coolant level in the radiator and top up if necessary.

FLYWHEEL

Remove and refit 12.53.07

Removing

- 1 Remove the front floor. 76.10.12.
- 2 Remove the seat base. 76.70.06.
- 3 Remove the engine assembly. 12.41.01.
- 4 Remove the clutch assembly. 33.10.01.
- 5 Remove the flywheel bolts with the aid of a flywheel trap.

Refitting

- 6 Fit the flywheel to the crankshaft and tighten the securing bolts. Torque: 8,5 to 9,0 kgf. m (60 to 65 lbf. ft.).
- 7 Mount a dial test indicator to read off the flywheel face.
- 8 Check the run-out on the flywheel face, this must not exceed 0,05 mm (0.002 in.).
- 9 If the run-out is excessive, remove the flywheel and investigate the cause.
- 10 Reverse 1 to 4.

Overhaul 12.53.10

Procedure

- 1 Remove the flywheel. 12.53.07.
Wear or scoring on the flywheel pressure face may be corrected by machining, providing that the overall thickness of the flywheel is not reduced below the following applicable dimension.

Petrol engines 34,72 mm (1.375 in.)
Diesel engines 36,957 mm (1.455 in.)

- 2 Check the overall thickness of the flywheel, as it may have been previously machined.
- 3 If the flywheel is above the minimum thickness, the clutch face can be refaced as follows:
- 4 Remove the dowels.
- 5 Reface the flywheel over the complete surface.
- 6 Check the overall thickness of the flywheel to ensure that it is still above the minimum thickness.
- 7 Fit the dowels.
- 8 Refit the flywheel. 12.53.07.

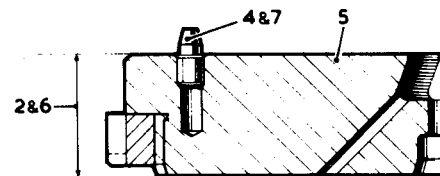
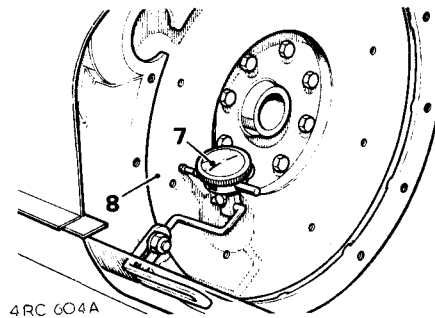
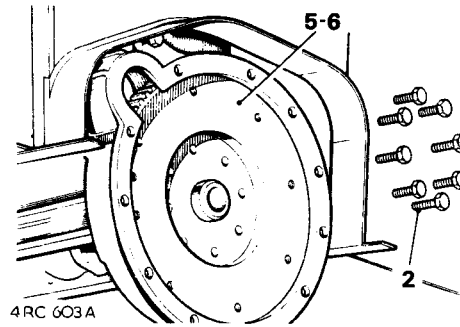

IRC 310

STARTER RING GEAR

Remove and refit 12.53.19

Removing

- 1 Remove the flywheel. 12.53.07.
- 2 Drill an 8,0 mm (0.312 in.) diameter hole axially between the root of any tooth and the inner diameter of the starter ring sufficiently deep to weaken the ring DO NOT allow the drill to enter the flywheel.
- 3 Secure the flywheel in a vice fitted with soft jaws.
- 4 Place a cloth over the flywheel to protect the operator from flying fragments.

WARNING: Take adequate precautions against flying fragments as the starter ring may fly asunder when being split.

- 5 Place a chisel immediately above the drilled hole and strike it sharply to split the starter ring.

Refitting

- 6 Heat the starter ring gear uniformly to between 225°C and 250°C (437°F and 482°F) but do not exceed the higher temperature.
- 7 Place the flywheel, flanged side down, on a flat surface.
- 8 Locate the headed starter ring gear in position on the flywheel with the square edge of the teeth against the flywheel flange.
- 9 Press the starter ring gear firmly against the flange until the ring contracts sufficiently to grip the flywheel.
- 10 Allow the flywheel to cool gradually DO NOT hasten cooling in any way.
- 11 Refit the flywheel. 12.53.07.

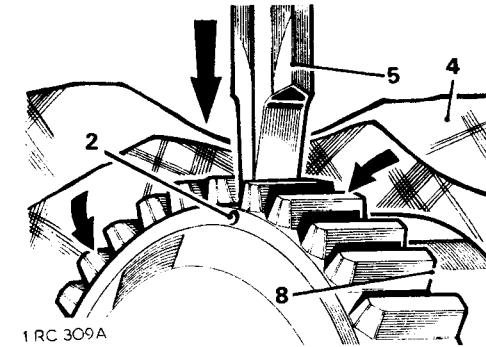

SPIGOT BEARING

Remove and refit 12.53.20

Removing

- 1 Remove the flywheel. 12.53.07.
- 2 Press the spigot bearing from the flywheel.

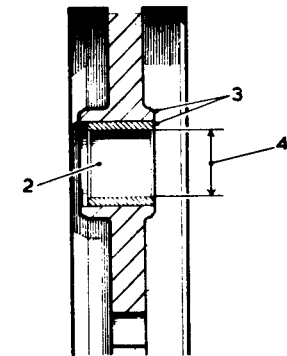

Refitting

- 3 Press in the new spigot bearing flush with the clutch side of the flywheel.
- 4 Ream the spigot bearing to 22,237 mm to 22,242 mm (0.8755 in. to 0.8757 in.).
- 5 Refit the flywheel. 12.53.07.

OIL FILTER ASSEMBLY

— EXTERNAL

Remove and refit 12.60.01

Removing

- 1 Prop open the bonnet.
- 2 Disconnect the electrical lead from the oil pressure switch.
- 3 Remove the oil filter.
- 4 Withdraw the joint washer.

Refitting

- 5 Smear both sides of the joint washer with general purpose grease.
- 6 Place the joint washer in the correct position on the cylinder block and fit the filter, tightening the bolts to 3,45 kgf m (25 lbf ft).
- 7 Reconnect electrical lead.
- 8 Check the sump oil level after a short engine run and top up as necessary to the 'high' mark on the oil level dipstick.

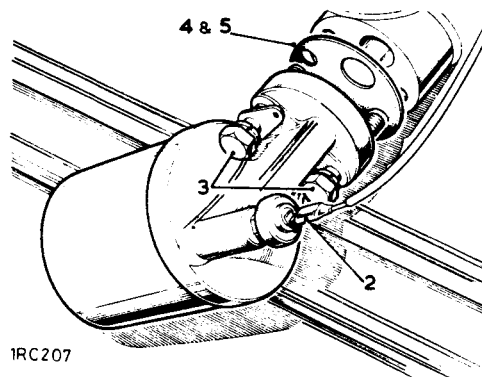

1RC207

OIL PUMP

Remove and refit 12.60.26

Removing

- 1 Remove the oil sump. 12.60.44.
- 2 Remove the oil pump.
- 3 Withdraw the oil pump drive shaft.

Refitting

- 4 Locate the longer splined end of the drive shaft into the oil pump.
- 5 Apply Hylomar Sealant to joint face of pump body and fit gasket. (Gasket fitted on later engines.)
- 6 Offer up the pump and drive shaft and engage the drive splines at the engine.
- 7 Secure the oil pump.
- 8 Fit the oil sump. 12.60.44.
- 9 Replenish the engine lubricating oil to the 'high' mark on the oil level dipstick.
- 10 Check the sump oil level after a short engine run and top up as necessary to the 'high' mark on the oil level dipstick.

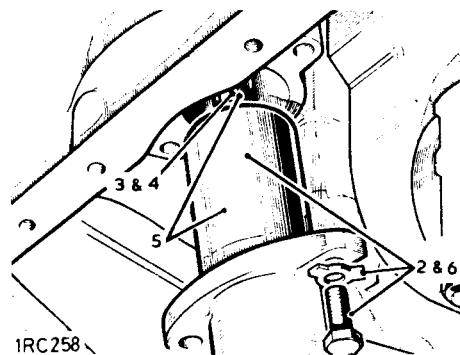

1RC258

OIL PUMP

Overhaul 12.60.32

Dismantling

- 1 Remove the oil pump. 12.60.26.
- 2 Straighten the lockwasher for the oil filter union nut.
- 3 Unscrew the oil filter union nut.
- 4 Withdraw the oil filter.
- 5 Withdraw the sealing ring.
- 6 Remove the oil pump cover.
- 7 Withdraw the pump gears.
- 8 Remove the plug for the oil pressure relief valve.
- 9 Withdraw the sealing washer.
- 10 Withdraw the oil pressure relief valve spring, plunger and ball.

Inspecting

- 11 If necessary the idler gear bush may be renewed. Press the new bush into the gear, drill the lubrication hole 3,175 mm (0.125 in.) diameter and ream the bush to 12,7 mm (0.500 in.) diameter.
- 12 Inspect the pressure relief valve ball seating and renovate, if necessary, using a locally manufactured lapping tool consisting of a steel ball, Rover Part No. 3748, soldered to suitable tubing.
- 13 The lapping tool may be installed in a drilling machine or hand brace and the ball seating refaced, using coarse grinding paste. The tool may then be removed and used to 'hand lap' the ball seating with fine grinding paste to a good finish. The seat must then be thoroughly cleaned.

continued

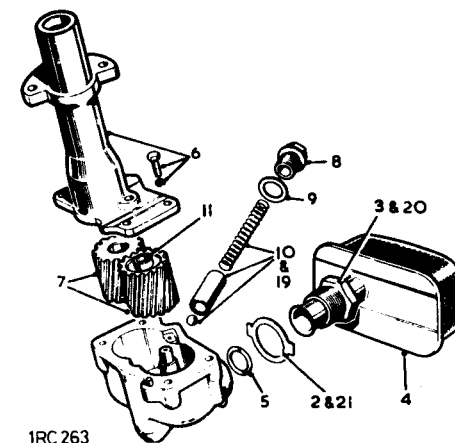

1RC263

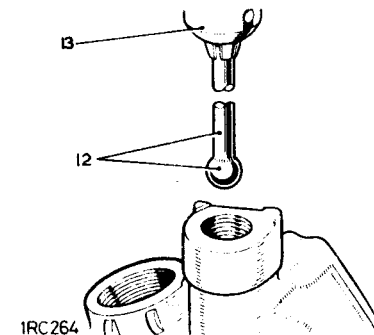

1RC264

- 14 Check the end float of the oil pump gears, as follows 15 and 16, and fit new parts as necessary.
- 15 Steel gear: 0,05 mm to 0,12 mm (0.002 in. to 0.005 in.).
- 16 Aluminium gear: 0,07 mm to 0,15 mm (0.003 in. to 0.006 in.).
- 17 Fit the pump gears to the body, with the plain portion of the drive gear bore uppermost.
- 18 Smear the joint faces with suitable jointing compound and fit the pump cover to the pump body, locating on the dowels.
- 19 Assemble the pressure relief valve components to the housing bore. When fitting the plunger, insert the end with the integral ball seating first.
- 20 Fit the oil filter to the pump.
- 21 Position the filter such that it will be square to the sump baffle plate when fitted and secure with the lock-washer.
- 22 Fit the oil pump to the engine. 12.60.26.

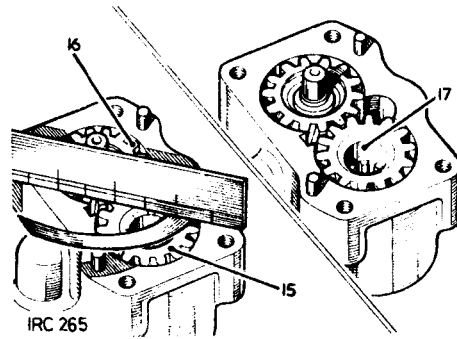

DATA

Pump gear end float	
Steel gear	0,05 mm to 0,12 mm (0.002 in. to 0.005 in.)
Aluminium gear	0,07 mm to 0,15 mm (0.003 in. to 0.006 in.)
Relief valve spring free length	67,82 mm (2,670 in.)

OIL SUMP

Remove and refit 12.60.44

Removing

- 1 Prop open the bonnet.
- 2 Remove the oil filler cap.
- 3 Remove the sump drain plug.
- 4 Allow the oil to drain, then refit the drain plug and sealing washer.
- 5 Remove the sump.
- 6 Withdraw the joint washer.

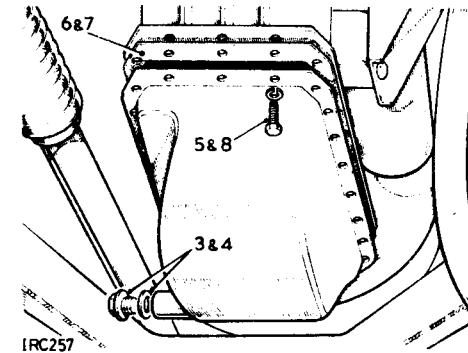

Refitting

- 7 Place a new joint washer in position.
- 8 Fit the sump, and tighten bolts to 1,65 kgf m (12 lbf ft).
- 9 Replenish the engine lubricating oil to the 'high' mark on the oil level dipstick.
- 10 Reverse 1 and 2.
- 11 Check the sump oil level after a short engine run and top up as necessary to the 'high' mark on the oil level dipstick.
- 12 After 1600 km (1000 miles) running, recheck sump bolts for correct torque as follows:
- 13 Slacken each bolt in turn approximately one flat, then retighten to 1,65 kgf m (12 lbf ft).

TIMING GEAR COVER AND OIL SEAL

Remove and refit

Gear cover 1 to 14 and 18 to 24 12.65.01
Oil seal 1 to 24 12.65.05

Service tool: 530102 Spanner for starter dog for three-bearing engine only; 530102A for three- and five-bearing engines.

NOTE: On initial assembly of the engine the mud shield around the oil seal is rivetted in position on the timing gear cover. If this has been removed in service however, the rivets may have been substituted with self tapping drive screws. In this case the oil seal may be changed without removing the timing gear cover provided that on refitting the mud shield is allowed to finally pull the oil seal into position to ensure a positive location.

Removing

- 1 Open and prop the bonnet.
- 2 Remove the radiator and front panel assembly. 26.40.01.
- 3 Slacken the alternator fixings and remove the fan belt.
- 4 Remove the alternator adjusting link.

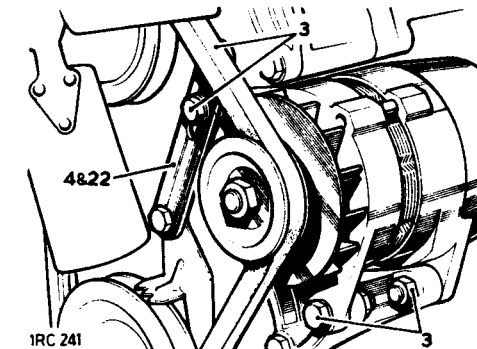

- 5 With the vehicle in gear with hand-brake on, slacken the starter dog.

- 6 Remove the starter dog. 530102.
- 7 Withdraw the crankshaft pulley.
If only the oil seal is to be changed, see NOTE above.
- 8 Remove the fan blades and pulley.
- 9 Disconnect the by-pass pipe from the thermostat housing.
- 10 Remove the timing cover fixings, including those at the sump front flange.
- 11 Withdraw the timing cover. NOTE: Slacken front side sump bolts for ease of timing cover removal.
- 12 Withdraw the joint washer from the timing cover.
- 13 Withdraw the joint washer from the water inlet.

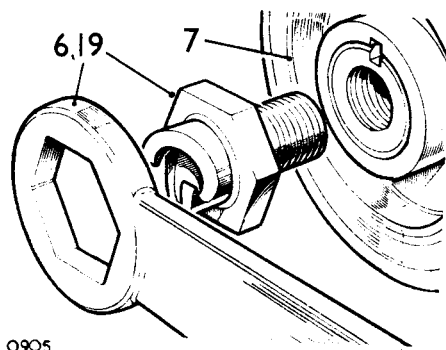

0905

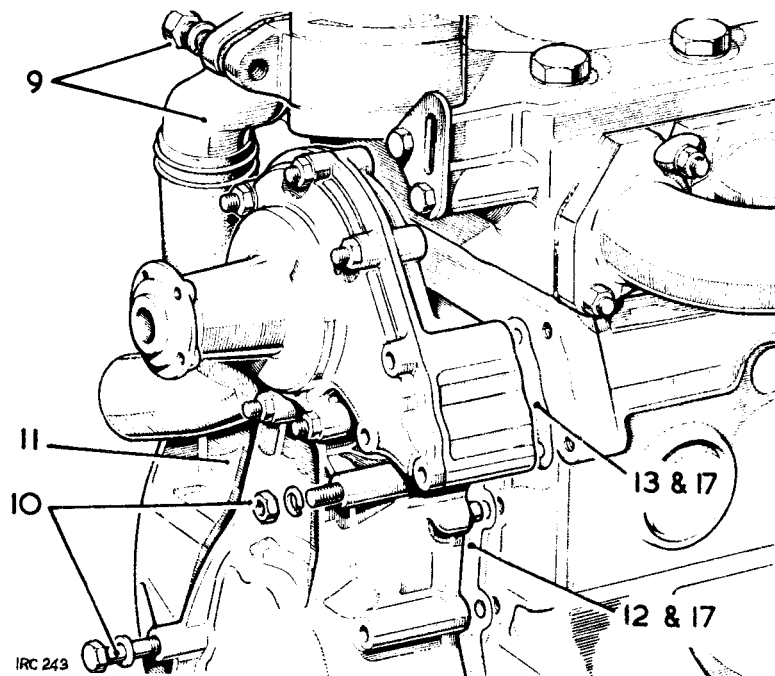

IRC 243

- 14 Drill out the rivets and drive the oil seal from the timing cover.
- 15 Smear the outside diameter of the new oil seal with Hylomar PL32/M jointing compound.
- 16 Press the oil seal into the timing cover and substitute the rivets with the self tapping drive screws supplied.

Refitting

NOTE: It is of advantage temporarily to remove the fixing stud from the cylinder block front face. This will enable the front cover to be lifted sufficient to clear the edge of the sump gasket when offering the front cover to the engine.

- 17 Smear general purpose grease on both sides of the front cover and water inlet joint washers.
- 18 Reverse 7 to 13.
- 19 Fit the starter dog. Torque: Petrol engines: 20,5 kgf. m (150 lbf. ft.). Diesel engines: 27,65 kgf. m (200 lbf. ft.).
- 20 Fit the alternator adjusting link.
- 21 Adjust the fan belt to give 6,5 to 9,5 mm (0.250 to 0.375 in.) free movement when checked midway between the fan and alternator pulleys.
- 22 Reverse 1 to 3.

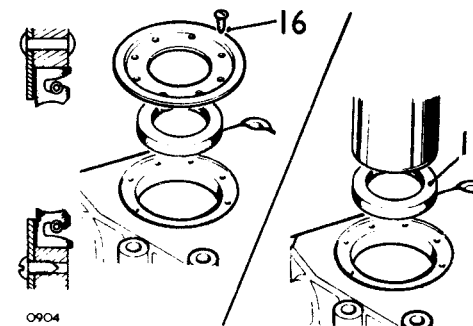

0904

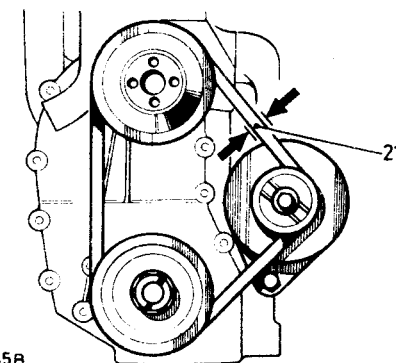

IRC245B

TIMING GEARS – Petrol**Remove and refit**

12.65.22

Service tool: 507231 Chainwheel extractor

Removing

- 1 Remove the bonnet. 76.16.01.
- 2 Remove the radiator and front panel assembly. 26.40.01.
- 3 Remove the timing gear cover. 12.65.01.
- 4 Remove the timing chain tensioner. 12.65.28.
- 5 Withdraw the timing chain.
- 6 Withdraw the chainwheel from the crankshaft.
- 7 Remove the fixings from the camshaft chainwheel.
- 8 Extract the chainwheel from the camshaft. 507231.

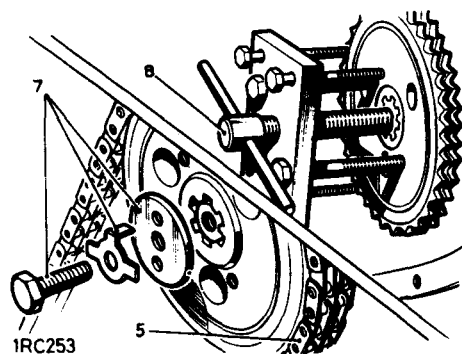
**Refitting**

- 9 Check that the key for the chainwheel is correctly located in the crankshaft slot.
- 10 Fit the chainwheel, large shoulder first, to the crankshaft.

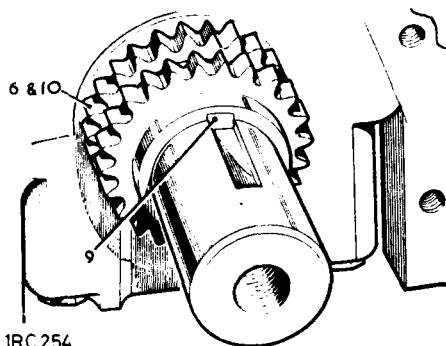

1RC 254

- 11 Locate the timing gear cover in position.
- 12 Fit the timing pointer.
- 13 Locate the crankshaft pulley in position.
- 14 Rotate the crankshaft until the timing mark in the crankshaft pulley is aligned with the longest tongue on the timing pointer (No. 1 piston at TDC).

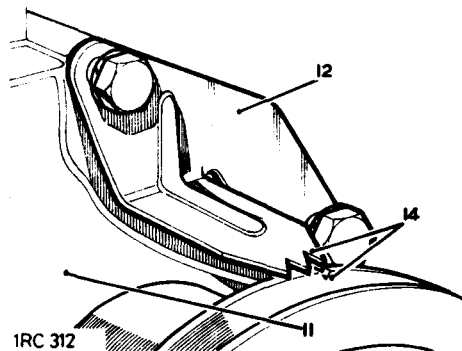

1RC 312

- 15 Without disturbing the crankshaft, remove the pulley, timing pointer and gear cover.
- 16 Fit the camshaft chainwheel, using keyway marked 'P'.
- 17 Rotate the camshaft chainwheel until the groove marked 'P' is in line with the centre of the tapped hole, as illustrated.

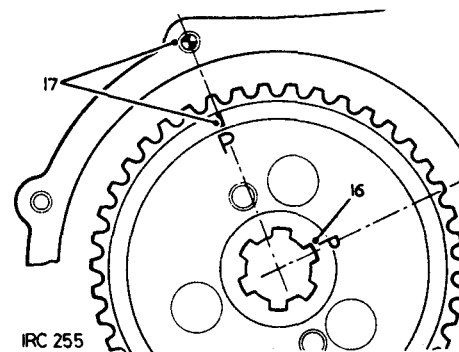

1RC 255

- 18 Retaining the chainwheels in the set positions, fit the timing chain ensuring that there is no slack chain on the driving side.

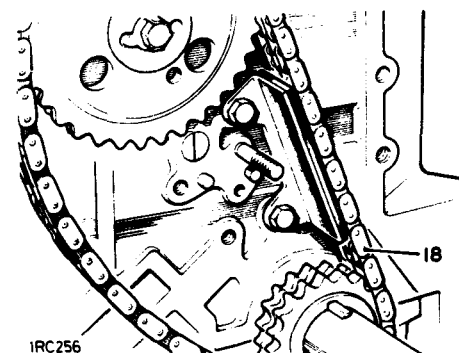

1RC256

- 19 If it is not possible to obtain a taut fit on the driving side of the chain with the chainwheels in the set positions, withdraw the camshaft chainwheel without disturbing the set position of the camshaft, and refit the chainwheel using one of the alternative keyways. This procedure may be repeated until a taut chain is obtained on the driving side with the camshaft and crankshaft in their previously set positions.
- 20 Reverse 1 to 4.

TIMING GEARS – Diesel

Remove and refit 12.65.22

Service tool: 507231 Chainwheel extractor

Removing

- 1 Remove the bonnet. 76.16.01.
- 2 Remove the radiator and front panel assembly. 26.40.01.
- 3 Remove the timing gear cover. 12.65.01.
- 4 Remove the timing chain tensioner. 12.65.28.
- 5 Withdraw the timing chain.
- 6 Withdraw the chainwheel from the crankshaft.
- 7 Remove the fixings from the camshaft chainwheel.
- 8 Extract the chainwheel from the camshaft. 507231.

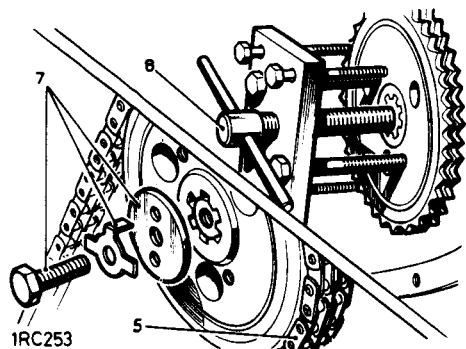

1RC253

Refitting

- 9 Check that the key for the chainwheel is correctly located in the crankshaft slot.
- 10 Fit the chainwheel to the crankshaft.

CAUTION: When turning the crankshaft do not allow the pistons to foul the valves. If necessary, turn the camshaft to enable the crankshaft setting to be obtained.

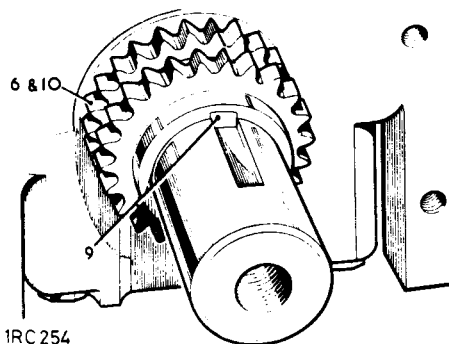

1RC254

- 11 Turn the crankshaft in the direction of rotation until the EP mark on the flywheel is aligned with the timing pointer.

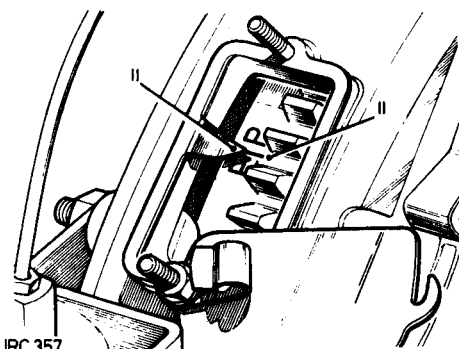

1RC357

- 12 Fit the chainwheel to the camshaft using any keyway.
- 13 Remove the engine top cover.
- 14 Turn the camshaft until No. 1 cylinder exhaust valve is fully closed and set the tappet clearance to 0,25 mm (0.010 in.).

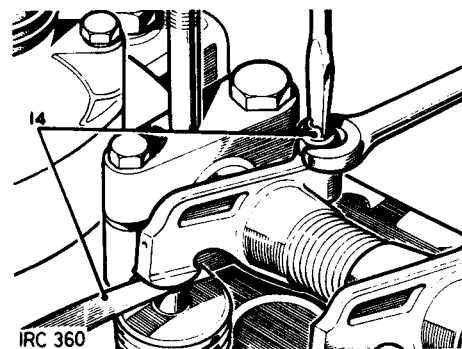

1RC360

- 15 Mount a dial test indicator to enable the 'fully open' position of the valve to be ascertained.
- 16 Turn the camshaft in the direction of rotation until the rocker pad has nearly opened the valve fully. Stop camshaft rotation.

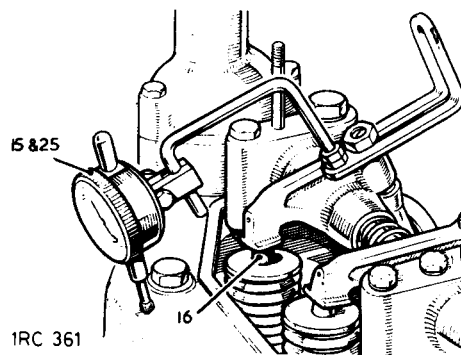

1RC361

- 17 Suitably mark the chainwheel and rear casing relative to each other.
- 18 Note the reading on the dial test indicator, then continue turning the camshaft in the direction of rotation until the dial test indicator needle has reached the same position as previously noted. Stop camshaft rotation.
- 19 Suitably mark the chainwheel adjacent to the mark previously made on the rear casing.
- 20 Make a third mark on the chainwheel to bisect the angle between the two previously made marks.

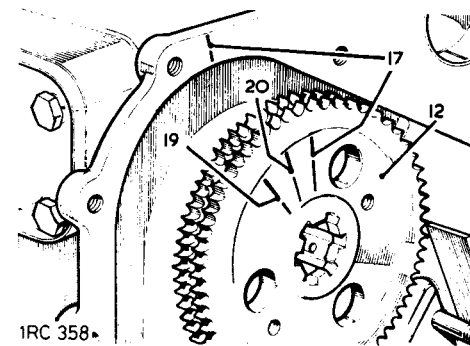

1RC358

- 21 Turn the camshaft against the direction of rotation and align the middle mark on the chainwheel with the mark on the rear casing. No. 1 exhaust valve is now fully open.
- 22 Retaining the chainwheels in the set positions, fit the timing chain ensuring that there is no slack chain on the driving side.

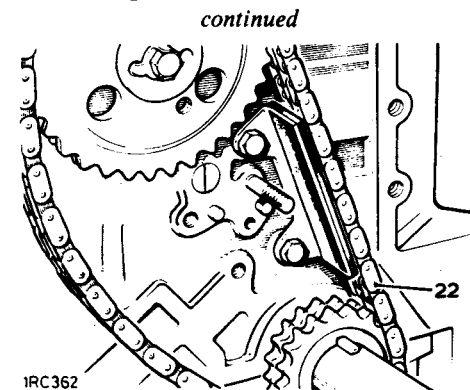

1RC362

- 23 If it is not possible to obtain a taut fit on the driving side of the chain with the chainwheels in the set positions, withdraw the camshaft chainwheel without disturbing the set position of the camshaft, and refit the chainwheel using one of the alternative keyways. This procedure may be repeated until a taught chain is obtained on the driving side with the camshaft and crankshaft in their previously set positions.

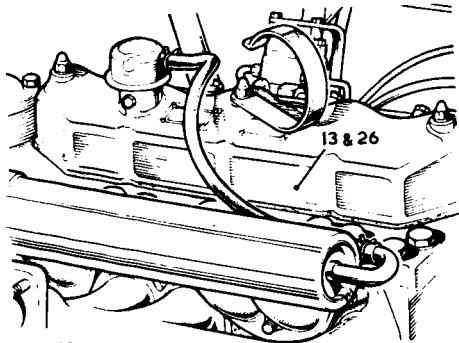

IRC359

- 24 Secure the fixings for the camshaft chainwheel and engage the lockwasher.
25 Remove the dial test indicator.
26 Refit the engine top cover.
27 Reverse 1 to 4.

TIMING CHAIN TENSIONER

Remove and refit 12.65.28

Removing

- 1 Remove the bonnet. 76.16.01.
- 2 Remove the radiator and front panel assembly. 26.40.01.
- 3 *Petrol engines:* Turn the crankshaft in the direction of rotation until the timing mark on the crankshaft pulley is aligned with the centre tongue of the timing pointer.
- 4 *Diesel engines:* Turn the crankshaft in the direction of rotation until the EP mark on the flywheel is aligned with the timing pointer.

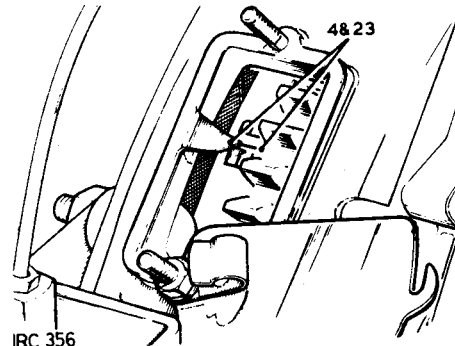

IRC 356

- 5 Remove the timing gear cover. 12.65.01.
- 6 Remove the tensioner ratchet and spring.
- 7 Remove the fixings from the piston housing.
- 8 Compress the tensioner spring by hand and withdraw the tensioner assembly complete.
- 9 Clean the tensioner components in clean fuel.
- 10 Fit a new piston and housing if unduly worn.
- 11 If the tensioner cylinder bush is unduly worn, fit a new cylinder and bush complete.
- 12 Fit a new idler wheel and ratchet arm if the bushes are unduly worn.
- 13 Fit a new chain vibration damper if the rubber pad is grooved.

- 14 Ensure that all oil passage drillings are clear.
- 15 *Petrol engines:* if required, remove the non-return valve plug, spring and ball.

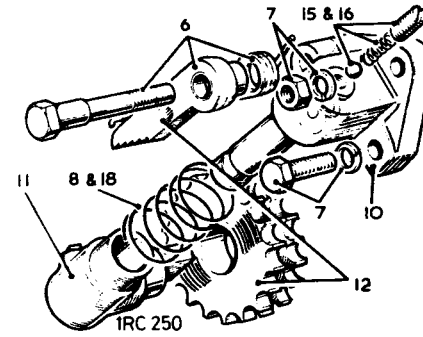

Refitting

- 16 *Petrol engines:* If removed, refit the non-return valve ball, spring and plug.
NOTE: On later petrol engines the diesel type timing chain tensioner assembly is fitted.
- 17 Assemble together, the piston housing, tensioner spring, cylinder and idler wheel.
- 18 Compress the assembly against the tensioner spring.
- 19 Fit the assembly to the engine, locating the piston housing onto the dowels and the cylinder spigot into the slot.

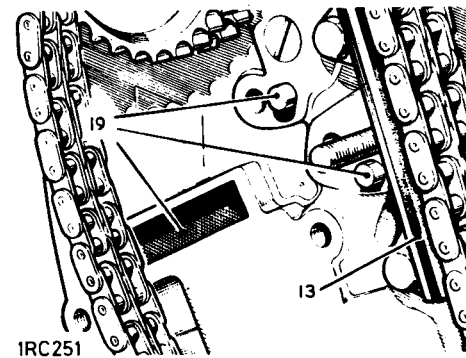

IRC251

- 20 Fit the ratchet and spring and allow the idler wheel to take up the timing chain slack.

- 21 If necessary, adjust the position of the chain vibration damper to allow 0,25 mm (0.010 in.) maximum clearance between the timing chain and the vibration pad.

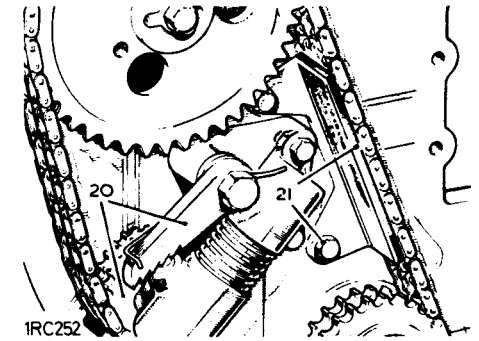

IRC252

- 22 *Petrol engines:* Temporarily, refit the timing gear cover, timing pointer and crankshaft pulley, and ensure that the timing marks are still correctly aligned. Then providing that the camshaft has not been rotated, the engine valve timing should be correct. If there is any doubt, check the valve timing. 12.65.22.

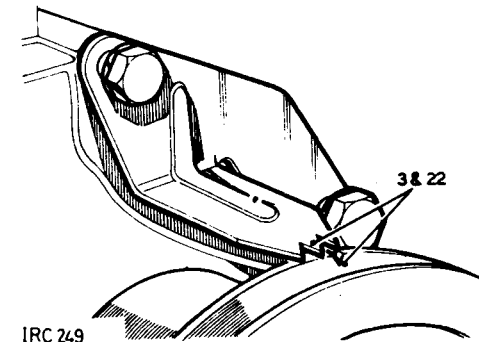

IRC 249

- 23 *Diesel engines:* Check that the EP mark on the flywheel is still aligned with the timing pointer. Then providing that the camshaft has not been rotated, the engine valve timing should be correct. If there is any doubt, check the valve timing. 12.65.22.
- 24 Fit the timing gear cover. 12.65.01.
- 25 Reverse 1 and 2.

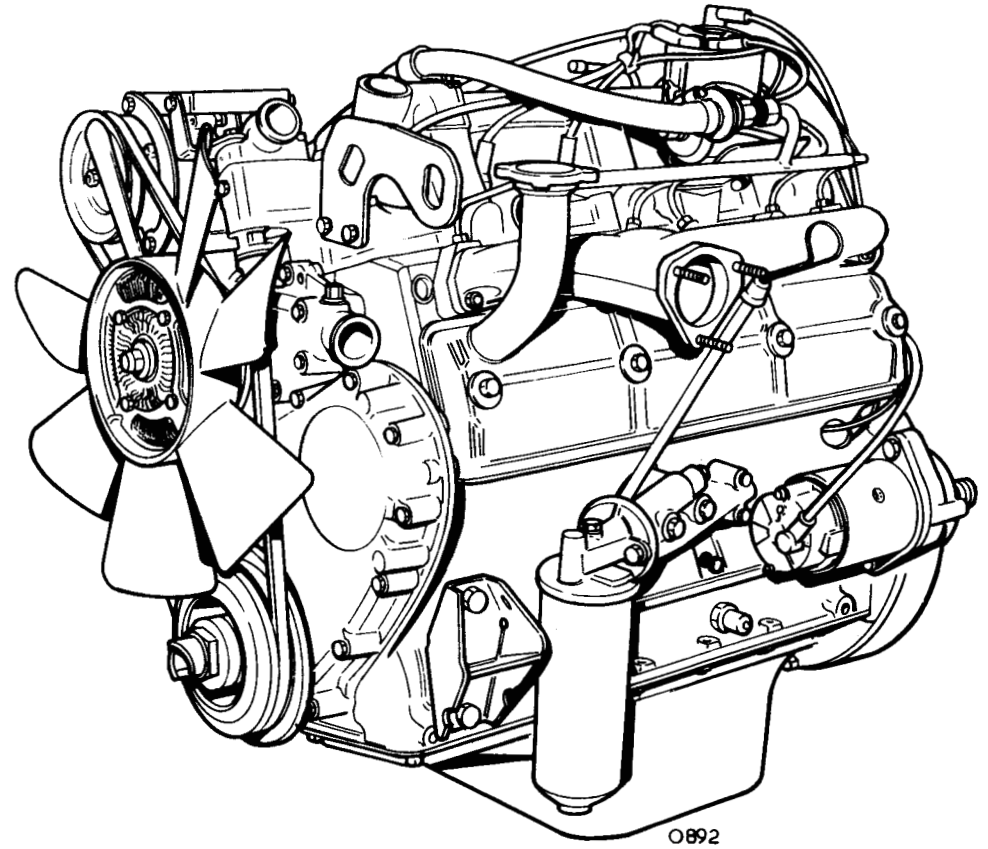
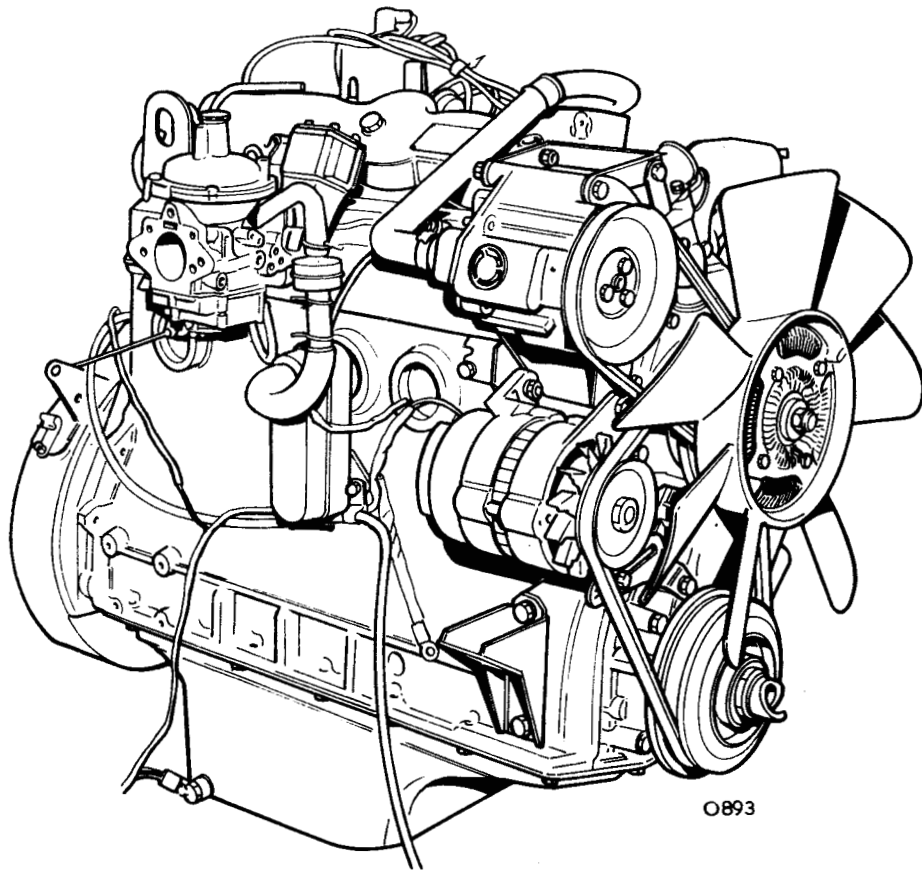

2.6 litre – 6 cylinder Engine

2.6 litre – 6 cylinder Engine

DISTRIBUTOR AND OIL PUMP DRIVE SHAFT

Remove and refit 12.10.22

Removing

- 1 Remove the distributor and short drive shaft. 86.35.20.
- 2 Remove the side rocker cover.

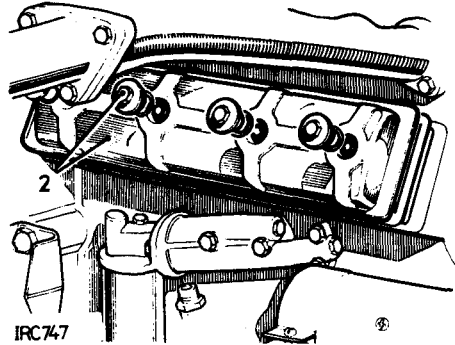

IRC 747

- 3 Remove the oil feed bolt and lock washer locating the distributor housing inside the rocker chamber.
- 4 Lift out the distributor housing.
- 5 Withdraw the drive shaft.

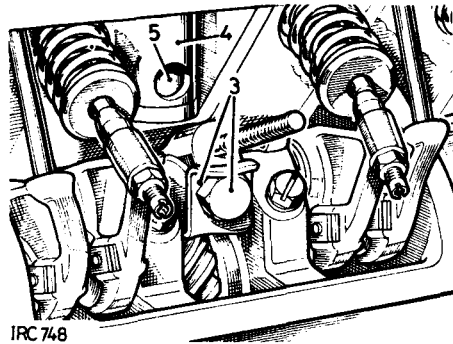

IRC 748

Refitting

- 6 Rotate the engine in direction of rotation until the TDC mark on the crankshaft pulley aligns with the timing pointer, with both valves on No. 1 cylinder fully closed (i.e. No. 1 cylinder commencing firing stroke).

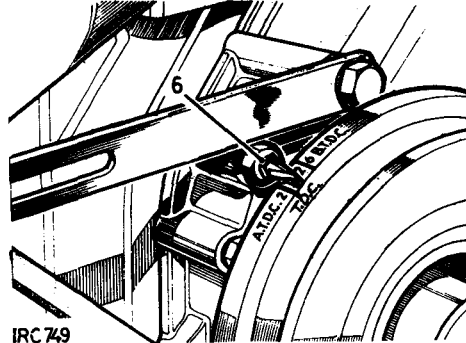

IRC 749

- 7 Fit the oil pump and distributor gear drive shaft to the engine with the lower splines engaged in the oil pump, and the skew gear engaged with the camshaft.
- 8 Turn the drive shaft using a suitable screwdriver, until the offset drive slot in the end of the shaft is positioned as illustrated.
- 9 Fit the distributor housing to the engine and locate and secure with the oil feed bolt and lock washer.
- 10 Reverse 1 and 2.

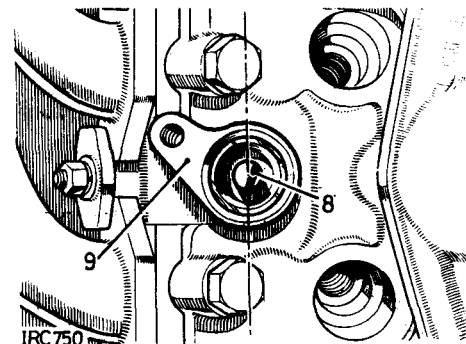

IRC 750

CAMSHAFT

Remove and refit 12.13.01

Service tools: 530101 Extractor for camshaft
507231 Extractor for chainwheel

Removing

- 1 Remove the radiator and grille panel. 26.40.01.
- 2 Remove the exhaust manifold. 30.15.10.
- 3 Remove the timing gear cover. 12.65.01.
- 4 Remove the timing chain tensioner. 12.65.28.
- 5 Remove the camshaft chainwheel and timing chain. Extractor 507231.
- 6 Remove the camshaft thrust plate.
- 7 Remove the side rockers and shafts. 12.29.36.
- 8 Remove the distributor and short drive shaft. 86.35.20.
- 9 Remove the oil pump and distributor gear drive shaft. 12.10.22.
- 10 Remove the six camshaft bearings locating screws.
- 11 Withdraw the camshaft until the bearings are clear of the housing. Extractor 530101.
- 12 Remove the bearings by separating the bearing halves. Keep the halves in related pairs as indicated by the figures marked on the end faces.
- 13 Withdraw the camshaft clear of the engine.
- 14 Withdraw the remaining bearing from the rear housing, utilising the oil relief holes for extraction purposes if required.

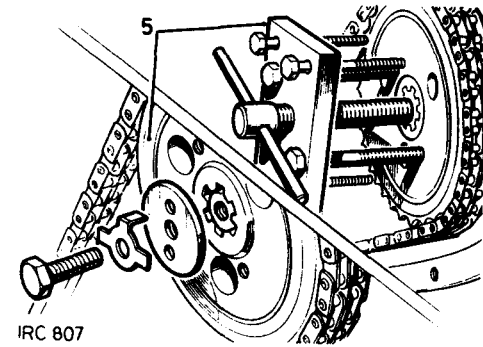

IRC 807

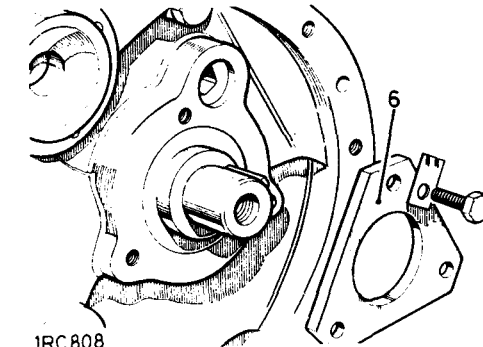

IRC 808

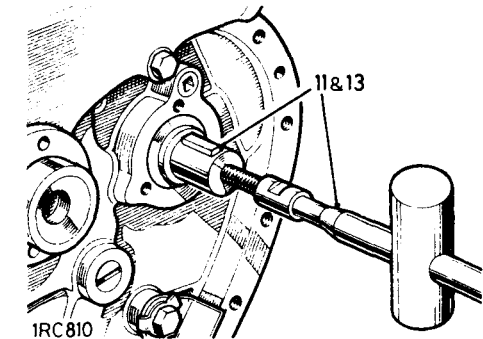

IRC 810

Refitting

- 15 Before attempting to fit the camshaft bearings to the cylinder block, ensure that the bearing halves fit together correctly on the dowels by checking that no light is visible between the joint faces.
- 16 The bearings must be fitted dry and should be a hand push fit in the cylinder block; they must always be renewed in paired halves and the numbers stamped on one of the end faces of the bearing halves must be adjacent.
- 17 Insert the camshaft partly into the cylinder block, allowing the distributor and oil pump drive gear to pass through the first and second intermediate housing webs.
- 18 Assemble the front and intermediate bearings on to their respective journals on the camshaft. Ensure that the dowelled joint faces are tightly fitted together and the locating holes in the bearings are in line with the holes in the housing webs.
- 19 Fit the rear bearing into the housing.
- 20 Place a suitable distance between the first and second intermediate bearings. The width of the distance piece to be approximately the distance between the bearing housings but allowing sufficient clearance for withdrawal.
- 21 Tap the camshaft rearwards until the bearings are fully home in their respective housings and the locating holes are aligned.
- 22 Remove the distance piece.
- 23 Lubricate the bearings through the locating bolt holes then fit the bearings fixings.
- 24 Fit the camshaft thrust plate.

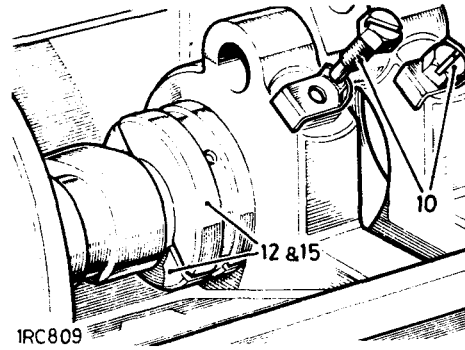

1RC809

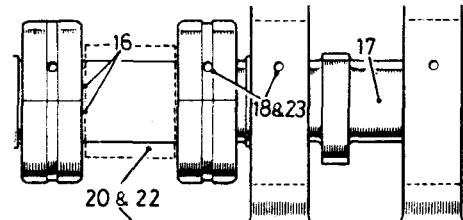

1RC811

DATA

Camshaft end float.....

- 25 Temporarily fit the camshaft chainwheel and check the camshaft end-float which must be 0,11 to 0,16 mm (0.0045 to 0.0065 in.). Replace the thrust plate if the end-float is excessive.

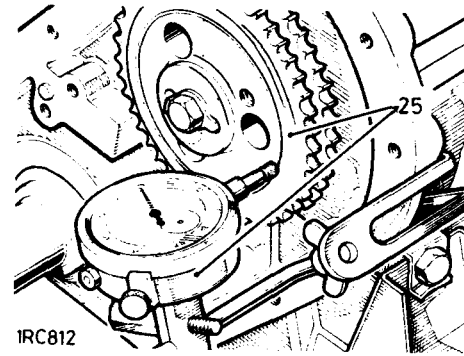

1RC812

- 26 Temporarily remove the camshaft chainwheel and fit the side rocker shafts. 12.29.36.
- 27 Fit the camshaft chainwheel and timing chain and set the valve timing. 12.65.12.
- 28 Fit the oil pump and distributor gear. 12.10.22.
- 29 Fit the distributor and short drive shaft. 86.35.20.
- 30 Reverse 1 to 4.

0,11 to 0,16 mm (0.0045 in. to 0.0065 in.).

CONNECTING RODS AND PISTONS

Remove and refit

12.17.01

Removing

NOTE: During the following procedures retain all components in related sets to facilitate re-assembly. If the pistons are not to be replaced, add location marks to ensure re-assembling in the same relative positions.

- 1 Remove the cylinder head. 12.29.10.
- 2 Remove the oil sump. 12.60.44.
- 3 With two pistons at bottom dead centre (BDC) remove the connecting rod cap fixings.

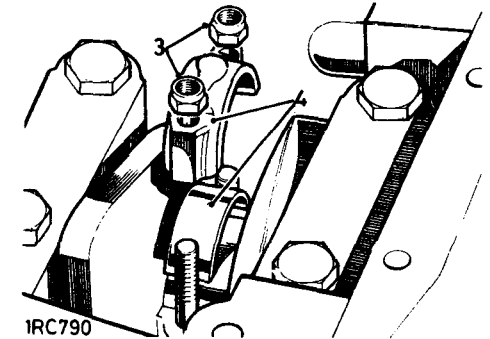

1RC790

- 4 Remove the caps and withdraw the connecting rod bearing halves. Retain the caps and bearings in related sets.
- 5 Withdraw the pistons and attached connecting rods from the top of the bore.
- 6 Position the remaining pistons at BDC and repeat the removal procedure.

continued

Refitting

NOTE: If replacement components are to be fitted, the checks detailed in 'overhaul' 12.17.10 must be carried out as necessary.

- 7 Position the piston rings so that the end gaps do not align with each other or with the gudgeon pin bore in the piston.
- 8 Enter the connecting rods into the appropriate cylinders and position the oil hole in the connecting rod and the flat on the piston crown away from the camshaft side of the engine.
- 9 Carefully insert the pistons into the cylinders, taking care not to damage the rings.
- 10 Lubricate the journals and bearing halves and fit the appropriate halves to the connecting rods and caps. The bearing halves are located by tongues, these to be positioned at the same side of the connecting rod in the grooves provided.
- 11 Fit new bearing cap nuts and tighten to 2,8 kgf. m (20 lbf. ft.).
- 12 Reverse 1 and 2.

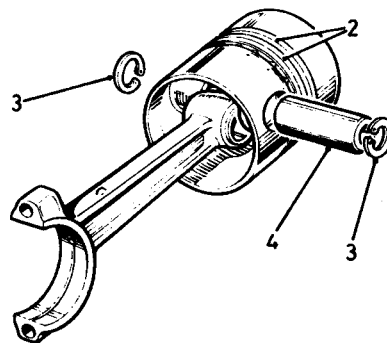
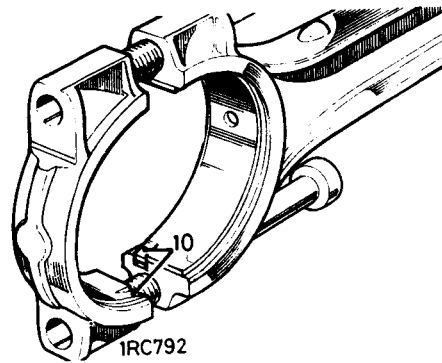
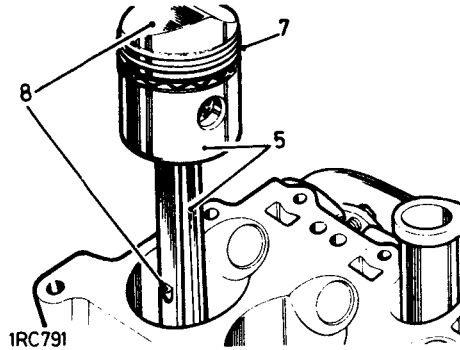
**Overhauling pistons****Original Pistons**

- 5 Remove the carbon and deposits, particularly from the ring grooves.
- 6 Examine the pistons for damage or excessive wear - see under 'New pistons' for clearance dimensions - fit new replacements as necessary.

New Pistons

Original pistons fitted to new engines at the factory are specially graded to facilitate assembly. The grading letter on top of the piston crown must be ignored when ordering new pistons. Genuine Land-Rover service standard size pistons are supplied 0,025 mm (0.001 in) oversize to allow for production tolerances on new engines. When fitting a new piston to a standard size cylinder block the bore must be honed to accommodate the piston with the correct clearances.

The clearance limits between the pistons and cylinder bores are 0,048 mm to 0,060 mm (0.0019 in. to 0.0024 in.), measured as described subsequently.

The temperature of the piston and cylinder block must be the same to ensure accurate measurements.

- 7 Check the piston diameter at the bottom of the skirt at right angles to the gudgeon pin.
- 8 Check the bore diameter at approximately half way down.

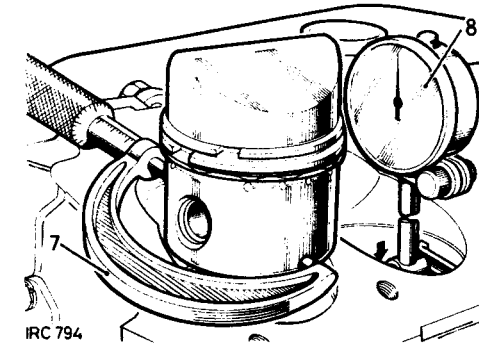

- 9 If gauge equipment is not available, the piston clearance can be assessed using long feeler gauges, 10 to 12.
- 10 Insert a long, suitably sized feeler gauge down the thrust side of the cylinder bore.
- 11 Insert the correct piston, inverted, into the cylinder bore and position it with the gudgeon pin parallel with the axis of the crankshaft.

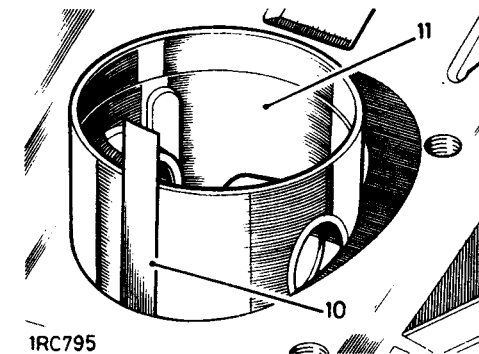
**CONNECTING RODS AND PISTONS****Overhaul**

12.17.10

Dismantling

NOTE: During the following procedures retain all components in related sets to facilitate subsequent assembly. If the same pistons are to be refitted, add location marks to ensure reassembling in the same relative position.

- 1 Remove the connecting rods and pistons. 12.17.01.
- 2 Remove the piston rings.
- 3 Remove the circlips from the gudgeon pin bosses.
- 4 Withdraw the gudgeon pins from the pistons.

- 12 Push the piston down the cylinder until the piston reaches its tightest point in the bore, at this point withdraw the feeler gauge — a steady resistance should be felt.
- 13 If standard size pistons are being fitted, select pistons from the range available until the clearance is satisfactory.
- 14 If new piston rings are to be fitted without reboring, deglaze the cylinder walls with a hone, without increasing the bore diameter. A deglazed bore must have a cross-hatch finish.
- 15 Check the compression and oil control rings gaps in the applicable cylinder, held square to the bore with the piston.
Compression rings gap: 0,38 mm to 0,50 mm (0.015 in. to 0.020 in.).
Oil control ring gap: 0,40 mm to 0,80 mm (0.015 in. to 0.033 in.).
Use a fine cut flat file to increase the gap if required. Select a new piston ring if the gap exceeds the limit.

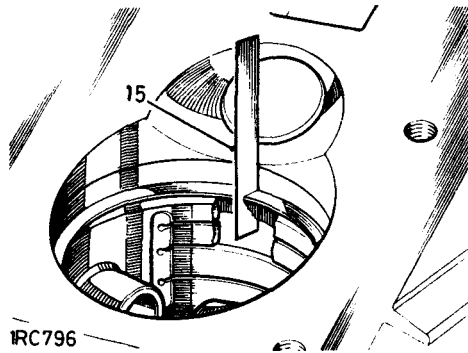

Reboring

- 16 The cylinder head is inclined at an angle of 22°; standard boring equipment can be used in conjunction with a special jig block 261288.
- 17 Where the maximum permitted boring tolerance is not sufficient to reclaim the bores, cylinder liners may be fitted.
- 18 Fitting the cylinder liners conforms to normal practice. Machine the cylinder block bores to 81,28 mm + 0,025 mm (3.200 in. + 0.001 in.) which will provide the liner with 0,07 mm to 0,10 mm (0.003 in. to 0.004 in.) interference fit.
- 19 Prior to pressing in the liner, allowance must be made for unavoidable rotation of up to 5 mm (0.187 in.), clockwise. To facilitate realignment should the liner not be positioned correctly at the first attempt, scribe lines down the sides of the liner from the two peaks, and make corresponding marks on the cylinder block.
- 20 Press in the liner, using a special press block 246650, until the top edge is level with the bottom of the exhaust valve pocket. Bland to the shape of the cylinder block.
Bore to the selected diameter to suit pistons. Liners may be bored to a maximum of 1,01 mm (0.040 in.).

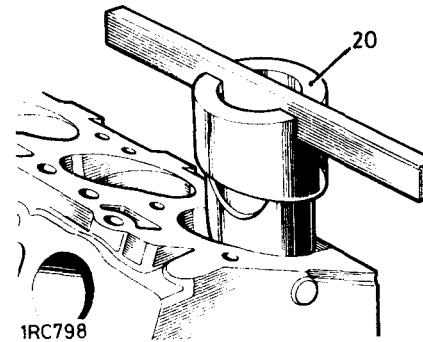
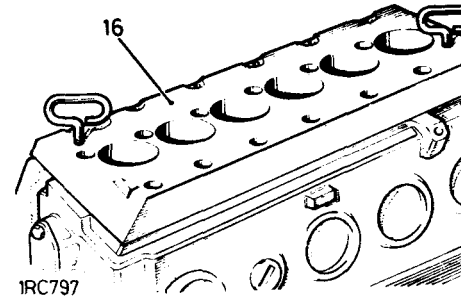

Assembling

- 21 Fit the oil control ring to the piston.
- 22 Check the oil control ring clearance in the piston groove. Clearance limits: 0,05 mm to 0,10 mm (0.002 in. to 0.004 in.).
- 23 Fit the two compression rings to the piston with the sides marked 'T' or 'Top' uppermost.
- 24 Check the compression ring clearance in the piston grooves. Clearance limits: 0,046 mm to 0,097 mm (0.0018 in. to 0.0038 in.).

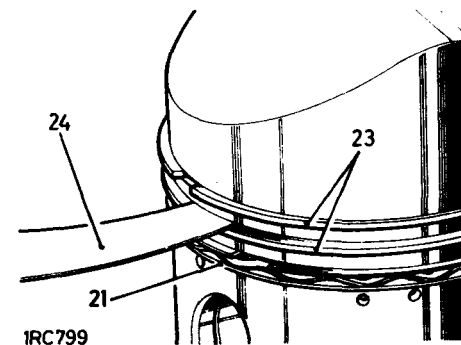

Connecting rods

- 25 Check the alignment of the connecting rod.
- 26 Check the gudgeon pin clearance in the connecting rod bush. Clearance limits: zero to 0,0241 mm (0.00095 in.).
- 27 If a new connecting rod small end bush is required, ensure that the oil holes are aligned when pressing in the replacement, then ream the bush to obtain the correct clearance, as above.
- 28 Check the fit of the gudgeon pin in the piston, the pin must not fall through either boss but be capable of being fitted by hand at normal room temperature 20°C (68°F).
Gudgeon pins of 0,025 mm and 0,076 mm (0.001 in. and 0.003 in.) oversizes are available.
- 29 Select the correct cap for each connecting rod as denoted by the number stamped near the joint faces. This number also indicates the crankshaft journal to which it must be fitted.
- 30 Assemble the caps, less bearing halves, to the respective connecting rods. Torque 2,8 kgf. m (20 lbf. ft.).
- 31 Slacken the fixing on one side of the cap only and check that there is no clearance at the joint face. If there is clearance, a new assembly must be fitted.

continued

Connecting rod bearing nip and clearance
NOTE: New bearing halves are supplied with a protective coating and must be degreased, prior to fitting, to remove the coating.

- 32 Fit the bearing halves to the connecting rod and cap, and secure the assembly. Torque 2,8 kgf. m (20 lbf. ft.).
- 33 Slacken the fixing on one side of the cap only and check the clearance between the joint faces. The clearance must be 0,05 mm to 0,10 mm (0.002 in. to 0.004 in.). The bearing nip can be corrected by selective assembly of the bearings shells; these are available in slightly varying thicknesses. Do not file or machine the caps or connecting rods to vary the bearing nip.

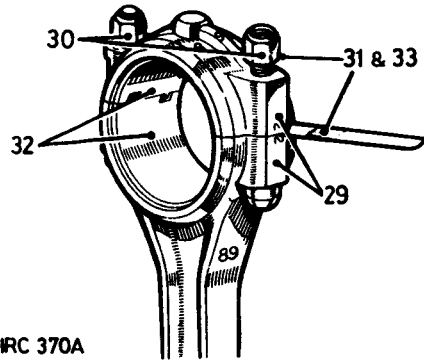

IRC 370A

- 34 Make a final check to prove the bearing clearance, using selected shim papers fitted between the journal and one half of the bearing shell. As the bearing clearance is taken up, the connecting rod will become stiff to rotate about the journal. The correct bearing clearance is 0,0114 mm to 0,043 mm (0.00045 in. to 0.0017 in.).

NOTE: As an alternative, 'Plastigauge' may be used to check the connecting rod bearing clearance. 35 to 41. Do not rotate the connecting rod or crankshaft while the Plastigauge is fitted, or the reading will be impaired.

- 35 Place a piece of 'Plastigauge' across the centre of the lower half of the crankshaft journal. 605238.
- 36 Fit the connecting rod complete with bearings to the applicable journal. Torque 2,8 kgf. m (20 lbf. ft.).
- 37 Remove the connecting rod cap and lower half bearing.
- 38 Using the scale printed on the 'Plastigauge' packet, measure the flattened 'Plastigauge' at its widest point. The graduation that most closely corresponds to the width of the 'Plastigauge' indicates the bearing clearance.

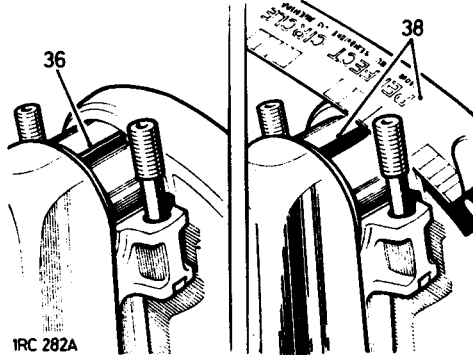

IRC 282A

- 39 The correct clearance with new or overhauled components is 0.0114 mm to 0,043 mm (0.00045 in. to 0.0017 in.).
- 40 If a new bearing is being fitted, use selective assembly to obtain the correct clearance.
- 41 Wipe off the 'Plastigauge' with an oily rag. DO NOT scrape it off.

Connecting rod end-float

- 42 Fit the connecting rods complete with bearings to their applicable journals. Torque 2,8 kgf. m (20 lbf. ft.).
- 43 Check the end float between the end face of the connecting rod and the journal shoulder. End float limits: 0,15 mm to 0,38 mm (0.006 in. to 0.015 in.).
- 44 Remove the connecting rods from the crankshaft and retain all parts in related sets.

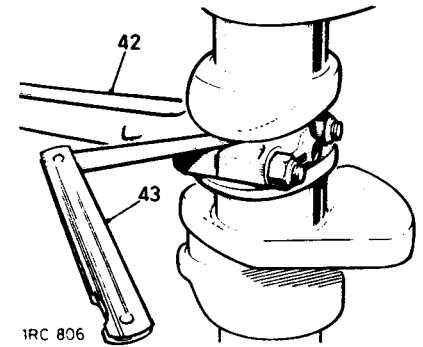

IRC 806

Assembling

- 45 Assemble the pistons to their respective connecting rods.
- 46 Fit new circlips to retain the piston gudgeon pins.
- 47 Refit the connecting rods and pistons. 12.17.01.

DATA

Pistons

Clearance in cylinder bore, measured at bottom of skirt at right angles to gudgeon pin. Standard size and oversize pistons.

0,048 mm to 0,060 mm (0.0019 in. to 0.0024 in.)

Piston rings

Compression (2)

Type

Cast iron. Marked 'T' or 'TOP' on upper side.

Gap in bore

0,38 mm to 0,50 mm (0.015 in. to 0.033 in.)

Clearance in groove

0,046 mm to 0,097 mm (0.0018 in. to 0.0038 in.)

Oil control

Type

Slotted, square friction edge. 0,38 mm to 0,80 mm (0.015 in. to 0.033 in.)

Gap in bore

Clearance in groove

0,05 mm to 0,10 mm (0.002 in. to 0.004 in.)

Gudgeon Pin

Clearance in connecting rod

Zero to 0,0241 mm (0.00095 in.)

Fit in piston

Push fit by hand

Connecting rods

Clearance, bearing to crankpin

0,0114 mm to 0,043 mm (0.00045 in. to 0.0017 in.)

End float on crankpin

0,15 mm to 0,38 mm (0.006 in. to 0.015 in.)

CRANKSHAFT REAR OIL SEAL

Remove and refit

12.21.20

Service tool: 270304 Guides for oil seal
600963 Engine lifting sling

Removing

- 1 Remove the bonnet. 76.16.01.
- 2 Remove the front floor. 76.10.12.
- 3 Remove the engine assembly. 12.41.01.
- 4 Remove the starter motor. 86.60.01.
- 5 Remove the oil sump. 12.60.44.
- 6 Remove the clutch assembly. 33.10.01.
- 7 Remove the flywheel. 12.53.07.
- 8 Remove the flywheel housing.
- 9 Remove the oil seal ring.
- 10 Remove the rear main bearing cap.
- 11 Remove the dowel located lower half of the oil seal retainer from the rear main bearing cap.
- 12 Remove the dowel located upper half of the oil seal retainer from the cylinder block.

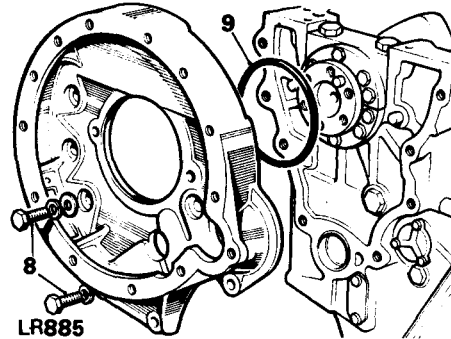
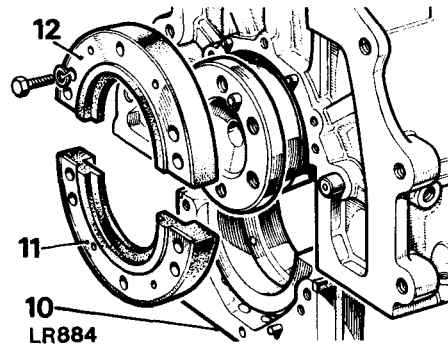

- 13 Remove the oil seal from the crankshaft.

Refitting

- 14 Assemble the garter spring on the crankshaft journal by engaging the hook and eye. Do not stretch the spring.
- 15 Move the assembled spring along the journal until it is against the thrower flange.
- 16 Apply Silicone Grease MS4 to the crankshaft oil seal journal and to both end faces of the split oil seal.
- 17 Open the split seal sufficiently to allow it to be fitted over the crankshaft oil seal journal. The recess in the oil seal must be towards the thrower flange and the garter spring.

NOTE: The oil seal must not be repeatedly fitted and removed from the crankshaft, as this can damage the sealing lip.

- 18 Position the garter spring so that the hook and eye is located mid-way between the split and hinge of the oil seal.

- 19 Using a small screwdriver, ease the spring into the recess in the oil seal.

- 20 Rotate the oil seal until the split is on the vertical axis pointing towards the cylinder head and in its approximate running position on the journal; this position is important.

NOTE: Do not degrease the seal retainer halves with trichlorethylene, but wipe clean with a dry cloth prior to applying Hylomar.

- 21 Apply Hylomar PL 32/M jointing compound, to the seal location diameter of both retainer halves.

- 22 Locate one half of the oil seal retainer onto the cylinder block dowels. The oil seal should be compressed to assist assembly, also ensure that it is correctly located in the retainer recess.

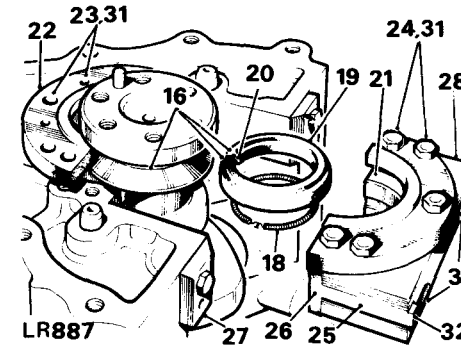

- 23 Secure the upper half of the oil seal retainer with the three inner bolts, leaving the outer bolts at each end finger tight at this stage.

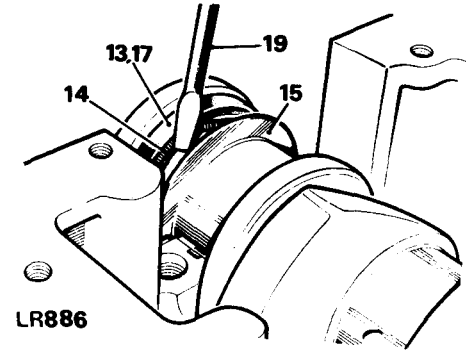

- 24 Secure the lower half of the oil seal retainer to the rear main bearing cap in the same manner as described for the upper half.

- 25 Apply Silicone Grease MS4 to the 'T' seals and fit them to the rear main bearing cap.

- 26 Trim the top edges of the 'T' seals to prevent them from fouling the cylinder block when being fitted.

- 27 Fit the seal guides to the crankcase. 270304.

- 28 Fit the rear main bearing cap complete with the seal retainer, 'T' seals and bearing shell to the crankcase until there is an 0,8 mm (0.030 in.) gap between the cap and the crankcase.

- 29 Check that the seal is correctly located in the retainer recess.

- 30 Tighten the bearing cap bolts ensuring that there is no buckling of the split seal or misalignment of the butt joint; Torque: 10 kgf. m (75 lbf. ft.).

- 31 Fully tighten all the bolts securing the retainer halves. Turn the bolt heads so that the hexagon corners will not foul the flywheel housing seal when fitting.

- 32 Trim the ends of the 'T' seals to leave 0,8 mm (0.030 in.) protruding from the bearing cap.

- 33 Reverse 1 to 19.

CRANKSHAFT

Remove and refit 12.21.33

Removing

- 1 Remove the bonnet. 76.16.01.
- 2 Remove the air cleaner. 19.10.04.
- 3 Remove the radiator and front panel assembly. 26.40.01.
- 4 Remove the front floor. 76.10.12.
- 5 Remove the engine assembly. 12.41.01.
- 6 Remove the oil sump. 12.60.44.
- 7 Remove the oil pump. 12.60.26.
- 8 Remove the timing gear cover. 12.65.01.
- 9 Remove the timing chain and tensioner. 12.65.28.
- 10 Remove the clutch assembly. 33.10.01.
- 11 Remove the flywheel. 12.53.07.

- 12 Remove the flywheel housing.
- 13 Remove the oil seal.
- 14 Remove the connecting rod caps and bearing lower halves. Retain in related sets.
- 15 Remove the main bearing caps and lift the crankshaft clear. Retain the bearing halves and caps in related sets.
- 16 Remove the oil seal from the crankshaft.
- 17 Remove the upper half of the oil seal retainer from the cylinder block.
- 18 If required, remove the chainwheel and key from the crankshaft.

Refitting

NOTE: If replacement components are to be fitted, the checks detailed in 12.21.46 must be carried out.

- 19 Locate the upper main bearing halves into the cylinder block.
- 20 Lubricate the bearings and crankshaft journals with clean engine oil, and place the crankshaft in position.

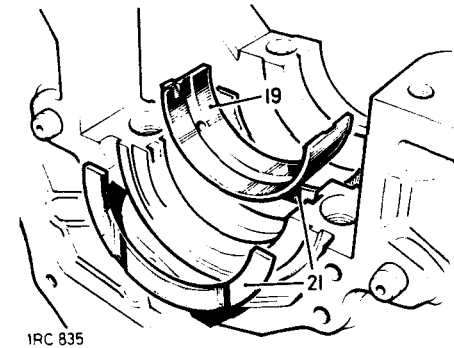
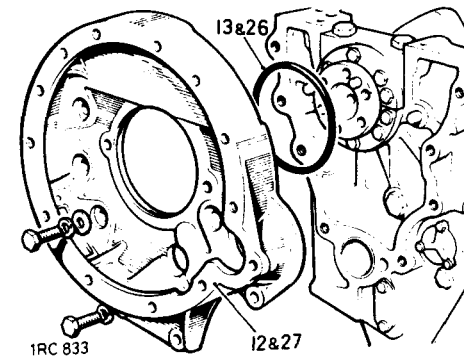
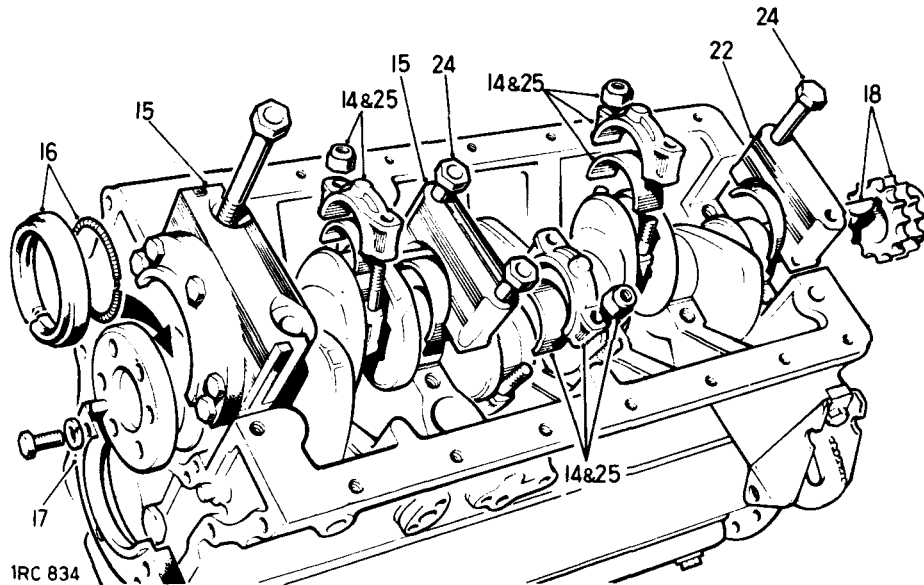

- 21 Insert a thrust washer at each side of the rear upper main bearing shell with the grooved faces towards the crankshaft webs.
- 22 Locate the bearing lower halves into numbers 1 to 6 main bearing caps. Fit the caps but do not fully tighten the fixings at this stage.
- 23 Fit the crankshaft rear oil seal and number 7 rear main bearing shell. 12.21.20.
- 24 Tighten the main bearing cap fixings. Torque: 10,0 kgf. m (75 lbf. ft.).
- 25 Fit the appropriate bearing halves and caps to the connecting rods, using NEW securing nuts. Torque: 2,8 kgf. m (20 lbf. ft.).

- 26 Fit the oil seal ring to the flywheel housing.
- 27 Refit the flywheel housing.
- 28 Refit the flywheel. 12.53.07.
- 29 Refit the clutch assembly. 33.10.01.
- 30 Reset the valve timing. 12.65.22.
- 31 Reverse 1 to 9.

CRANKSHAFT

Overhaul 12.21.46

Inspecting

- 1 Remove the crankshaft. 12.21.33.
- 2 Check each crankshaft journal for ovality. If ovality exceeds 0,040 mm (0,0015 in.), a reground or new crankshaft should be fitted.
- 3 Bearings for the crankshaft main journals and the connecting rod journals are available in the following undersizes:
 - 0,25 mm (0,010 in.)
 - 0,50 mm (0,020 in.)
 - 0,76 mm (0,030 in.)
 - 0,01 mm (0,040 in.)
- 4 Thrust washers for the crankshaft rear main journal, to control the crankshaft end float, are available in the following oversizes:
 - 0,06 mm (0,0025 in.)
 - 0,12 mm (0,005 in.)
 - 0,18 mm (0,0075 in.)
 - 0,25 mm (0,010 in.)
 - 0,31 mm (0,0125 in.)
- 5 Fit the front main bearing cap, less bearing halves, to the cylinder block. Torque 10,4 kgf. m (75 lbf. ft.).
- 6 Slacken the fixing on one side of the cap only and check that there is no clearance at the joint face. If there is clearance, a complete new cylinder block must be fitted.

- Repeat 5 and 6 for the remaining main bearing caps.

Main bearing nip and clearance

NOTE: New bearing halves are supplied with a protective coating and must be degreased prior to fitting, to remove the coating.

- Locate the bearing halves into the front main bearing cap and the cylinder block, and fit the cap to the block. Torque: 10,4 kgf. m (75 lbf. ft.).
- Slacken the fixing on one side of the cap only and check the clearance between the joint faces. The clearance must be 0,10 mm to 0,15 mm (0.004 in. to 0.006 in.).

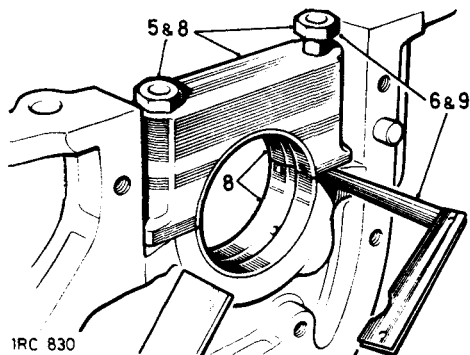

- The bearing nip can be corrected by selective assembly of the bearing halves; these are available in slightly varying thicknesses. Do not file or machine the caps or cylinder block to vary the bearing nip.
- Repeat 8 to 10 for the remaining main bearings.
- When the bearing nip has been checked, remove the caps and bearing shell bottom halves.
- Position a standard size thrust washer each side of the rear main bearing shell, top half, with the grooved faces away from the cylinder block. The thrust washer thicknesses must agree within 0,08 mm (0.003 in.).

- Place the crankshaft in position on the cylinder block.
- Mount a dial test indicator to read off the end of the crankshaft.
- Check the crankshaft end float. The correct end float limits are 0,05 mm to 0,15 mm (0.002 in. to 0.006 in.).
- The crankshaft end float can be adjusted by fitting oversize thrust washers. The variation of thrust washer thickness at each side must not exceed 0,08 mm (0.003 in.) to ensure that the crankshaft remains centralised.

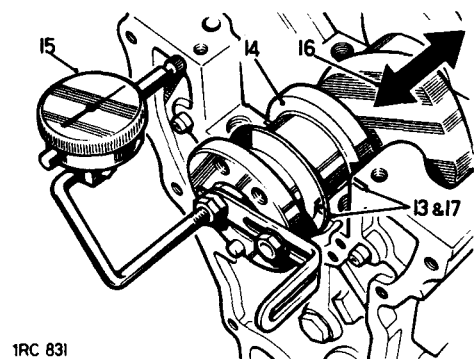

- Make a final check to prove the main bearing clearance, using a 0,063 mm (0.0025 in.) shim paper. Check each bearing in turn by fitting both bearing halves and the bearing cap, with the shim paper between the crankshaft and one half of the bearing. The crankshaft should resist rotation with the shim paper fitted, and move freely by hand with the shim paper removed.

NOTE: As an alternative, Plastigauge may be used to check the main bearing clearance, 19 to 26. Do not rotate the crankshaft while the Plastigauge is fitted, or the reading will be impaired.

- Locate the crankshaft in position on the upper bearing halves in the cylinder block.
- Place a piece of Plastigauge across the centre of the lower half of the crankshaft journal. 605238.

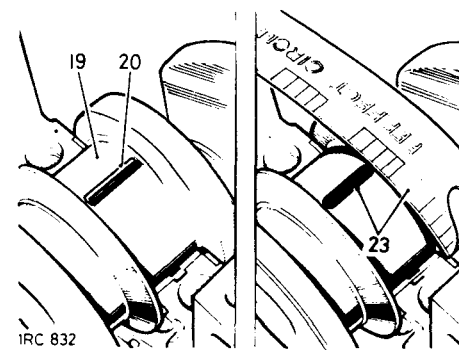

- Fit the bearing cap complete with the lower bearing half. Torque: 10,5 kgf. m (75 lbf. ft.).
- Remove the bearing cap and lower half bearing.
- Using the scale printed on the 'Plastigauge' packet, measure the flattened 'Plastigauge' at its widest point. The graduation that most closely corresponds to the width of the 'Plastigauge' indicates the bearing clearance.
- The correct clearance with new or overhauled components is 0,015 mm to 0,050 mm (0.0006 in. to 0.002 in.).
- If a new bearing is being fitted, use selective assembly to obtain the correct clearance.
- Wipe off the 'Plastigauge' with an oily rag. DO NOT scrape it off.
- Retain all components in related sets.
- Refit the crankshaft. 12.21.33.

DATA

Crankshaft

Journal diameter	67,0 mm - 0,0127 mm (2.6245 in. - 0.0005 in.)
Crankpin diameter	47,63 mm + 0,018 mm (1.875 in. + 0.00075 in.)
End float (controlled by thrust washers at rear bearing)	0,05 mm to 0,15 mm (.002 in. to .006 in.)
Regrind permissible by 0,25 mm (0.010 in.) stages to:	
	Undersize Journal dia. Crankpin dia.
	1,01 mm 65,63 mm 46,6 mm (0.040 in.) (2.584 in.) (1.835 in.)
Main bearing running clearance	0,015 mm to 0,050 mm (0.0006 in. to 0.002 in.)
Connecting rod bearing running clearance	0,0114 mm to 0,043 mm (0.00045 in. to 0.0017 in.)

CYLINDER PRESSURES

Check 12.25.01

Checking

- 1 Run the engine until it attains normal operating temperature.
- 2 Remove the sparking plugs.
- 3 Secure the throttle in the fully open position.
- 4 Check each cylinder in turn as follows:
- 5 Insert a suitable pressure gauge into the sparking plug hole.
- 6 Crank the engine with the starter motor for several revolutions and note the highest pressure reading obtainable.
- 7 If the pressure is appreciably less than the correct figure, the piston rings or valves may be faulty.
- 8 Low pressure in adjoining cylinders may be due to a faulty cylinder head gasket.

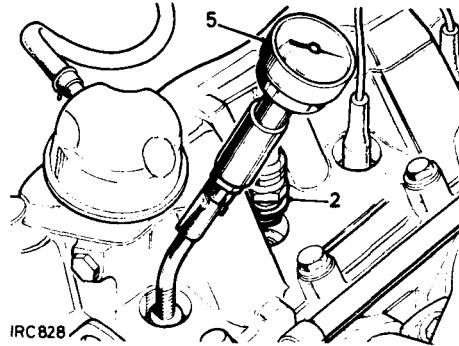
**DATA**

Compression ratio	7.8 : 1	7.0 : 1
Compression pressure	11,95 kgf. cm ² (170 lbf. in. ²)	9,84 kgf. cm ² (140 lbf. in. ²)
Cranking speed	300 rev/min	300 rev/min

CYLINDER HEAD

Remove and refit 12.29.10

Removing

- 1 Drain the coolant at the radiator and engine block.
- 2 Disconnect the brake servo pipe from the inlet manifold.
- 3 Remove the carburetter. 19.15.09.
- 4 Disconnect the accelerator control rod and return spring at the bell crank lever.
- 5 Disconnect the two temperature transmitter leads from the cylinder head.
- 6 Disconnect the rocker oil feed pipe at the rear of the cylinder head.
- 7 Remove the sparking plugs.
- 8 Disconnect the radiator top hose.
- 9 Disconnect the hose from the engine breather cap.
- 10 Remove the distributor. 86.35.20.
- 11 Remove the distributor vacuum pipe and retaining clip from the thermostat outlet pipe fixing.
- 12 Remove the special nuts and sealing washers and lift off the top rocker cover and joint washer.

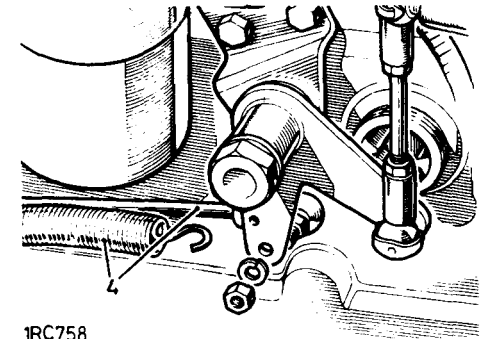

IRC 758

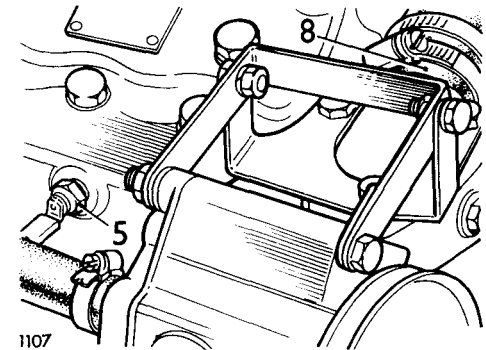

1107

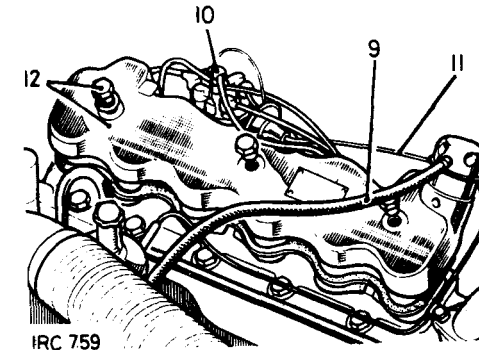

IRC 759

- 13 Slacken the locknuts and screw back the tappet adjusting screws.
- 14 Slacken the cylinder head fixings evenly and remove them.
- 15 Lift off the cylinder head and discard the cylinder head gasket.
- 16 Remove the 'O' ring seal from the connector by-pass to water pump.
- 17 Withdraw the tappet push rods and retain them in their fitted order.

Refitting

- 18 Remove the side rocker cover and fit the tappet push rods in their original positions.
- 19 Smear a new cylinder head gasket with oil and place on the face of the cylinder block, with the side marked 'this side up' uppermost.

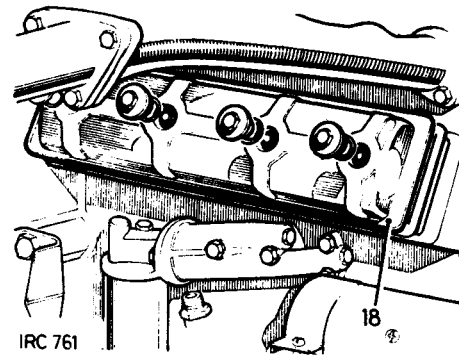

IRC 761

- 20 Use two old cylinder head bolts with their heads sawn off to locate the gasket and head. Cut a screwdriver slot across the diameter of the bolts to facilitate removal when the cylinder head is in position.
- 21 Position the cylinder head onto the block, at the same time position the 'O' ring seal onto the by-pass connector.
- 22 Ensure that the tappet push rods remain correctly seated.
- 23 Tighten the cylinder head bolts in the order shown and to the following torques:

- a. Bolts 'A' 7 kgf. m (50 lbf. ft.)
- b. Bolts 'B' 4 kgf. m (30 lbf. ft.)

- 24 Set the inlet valve tappet clearances to 0,15 mm (0.006 in.) in the following order:
Set No. 1 tappet with No. 6 valve fully open.
Set No. 2 tappet with No. 5 valve fully open.
Set No. 3 tappet with No. 4 valve fully open.
Set No. 4 tappet with No. 3 valve fully open.
Set No. 5 tappet with No. 2 valve fully open.
Set No. 6 tappet with No. 1 valve fully open.
- 25 Refit the side and top covers.
- 26 Fit the distributor. 86.35.20.
- 27 Reverse 1 to 8.
- 28 With the engine at normal running temperature, check the cylinder head fixings tightness, then the inlet valves tappet clearances, and tighten and reset as necessary.

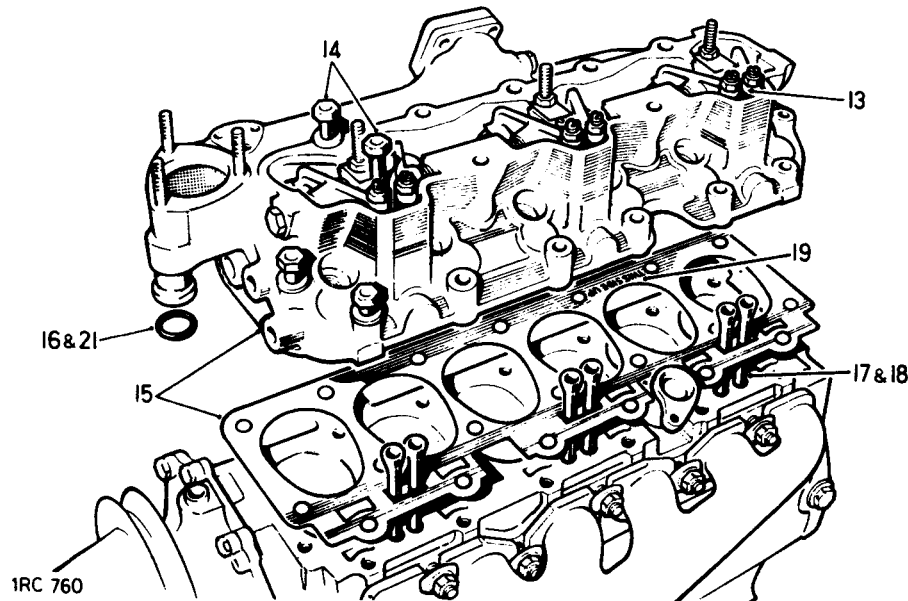

IRC 760

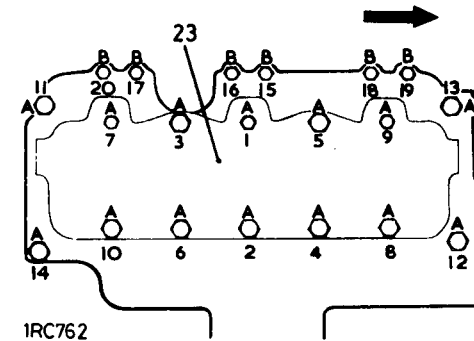

IRC762

CYLINDER HEAD

Decarbonise and top overhaul 12.29.21

Service tools: 262749 Rocker shaft extractor
276102 Valve Spring compressor
274401 Exhaust valve guide remover
274400 Inlet valve guide remover
600959 Exhaust valve guide replacer
601508 Inlet valve guide replacer
263050 Protection plate, insert removal
530625 Exhaust valve seat replacer

Cylinder head and inlet valves

Dismantling

- 1 Remove the cylinder head. 12.29.10.
- 2 Remove the thermostat housing and thermostat.
- 3 Remove the inlet valve rockers and shafts. 12.29.35.
- 4 Remove the inlet valve assemblies, using spring compressor 276102, and retain the components in sets related to their parent cylinder.

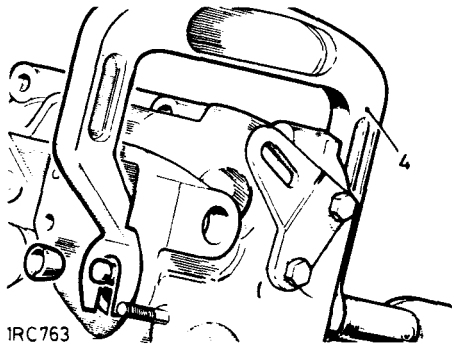

- 5 Withdraw the oil seals from the valve guides.
- 6 Remove combustion deposits from the cylinder head, valve ports and piston crowns, using only soft metal tools.
- 7 If necessary, remove the inlet valve seat inserts by grinding sufficient to weaken the insert, then prising out.
- 8 Drive out the inlet valve guides from the combustion chamber side, using remover 274400.

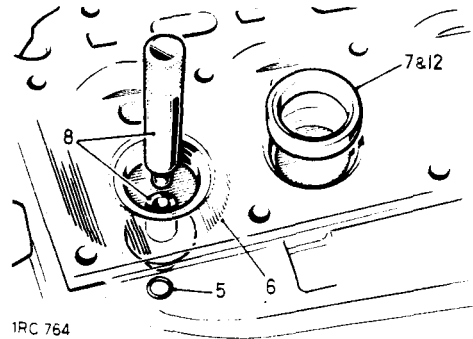

- 9 Inspect the valve spring pairs which must be an interference fit with each other.
- 10 Inspect the valve split cones and spring caps for general condition.
- 11 Inspect the cylinder head for general condition and for damage to threads.

Assembling

- 12 If replacement inlet valve seat inserts are to be fitted, warm the head evenly for a few minutes at 66°C (150°F) approximately (the normal operating temperature of a degreaser), enter the seat squarely into the cylinder head recess and press into position.

- 13 Lubricate and fit the inlet valve guides, together with the valve spring seating washers, using replacer 601508.

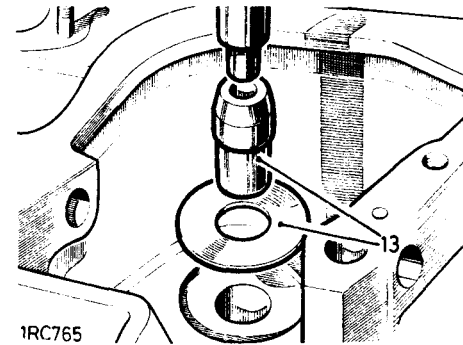

- 14 Face the inlet valve seats, both original and replacements, to 30° + ¼°, using the valve guides as pilots.
- 15 Check, and if necessary, reface the inlet valve faces to 30° - ¼°.

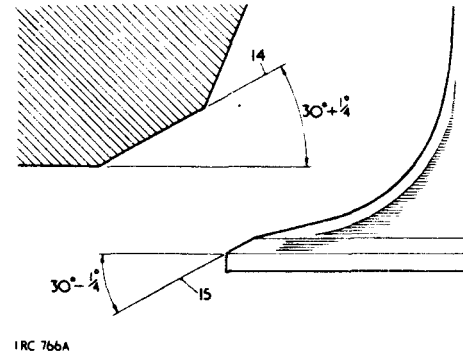

- 16 Lap each valve into its respective seat then thoroughly wash the assembly.
- 17 Lubricate the valve stems and reverse 4.
- 18 Reverse 2 and 3.
- 19 Place the cylinder head assembly aside pending refitting.

Dismantling the exhaust valves arrangement

- 20 Remove the exhaust manifold. 30.15.10.
- 21 Remove the side rocker cover and joint washer.
- 22 Mark the exhaust valves for refitting in correct sequence.
- 23 Slacken the tappet adjusting screws right off and set each rocker back on its cam.
- 24 Remove the exhaust valve assemblies, using spring compressor 276102, and retain the components in sets related to their parent cylinder.

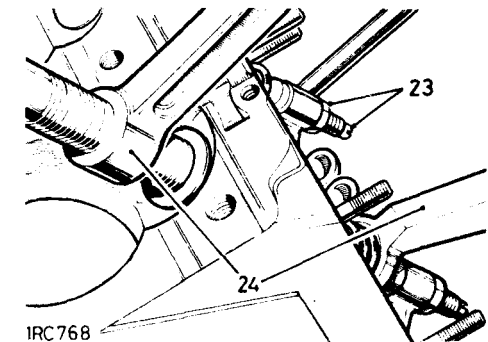

- 25 Remove the combustion deposits from the valves and ports.
- 26 Examine the valve seat inserts and valve guides. If replacement is necessary, first remove the exhaust valve rockers and shafts. 12.29.36.

NOTE: In installations where access is restricted, to replace valve guides on No. 5 or No. 6 cylinders may first require engine removal.

27 If necessary, remove the valve seat inserts, 28 and 29.

WARNING: Due to the extreme hardness of the seat inserts, take great care to avoid possible injury due to fragmentation.

28 Reduce the insert to a minimum thickness by grinding.

29 Secure the protection plate 263050 over the cylinder block face and break the seat insert, using a suitable chisel applied through the hole in the plate.

30 If necessary, drift out the exhaust valve guides, using remover 274401.

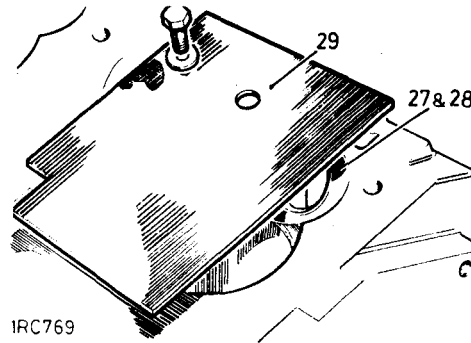

IRC769

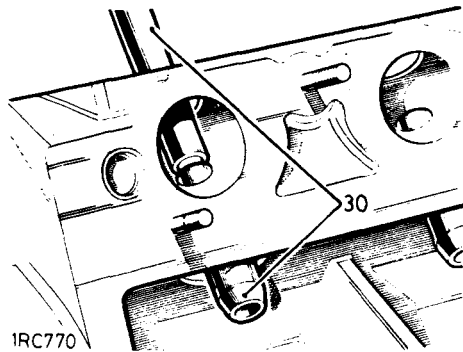

IRC770

Exhaust valves, seats and guides, refitting

31 If next exhaust seat inserts are to be fitted, clean the seat recess and pull the new insert into position, using special tool 530625. It is not necessary to heat the block or freeze the insert, but light taps on the tool may be required to ensure that the insert enters smoothly. Continue precautions against fragmentation, by fitting the protection plate 263050 and leaving it in position for a few minutes.

32 Lubricate the exhaust valve guides and carefully drift them into position, using replacer 600959.

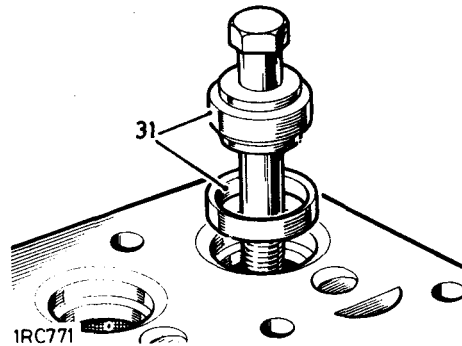

IRC771

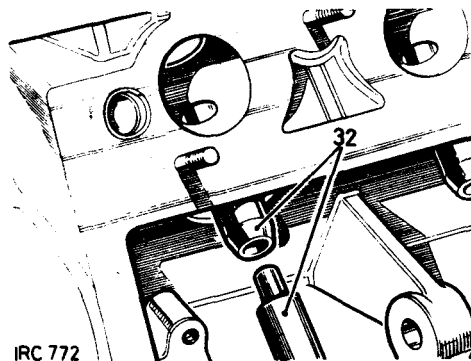

IRC 772

33 Use the valve guide as a pilot and cut the valve seat to $45^\circ + \frac{1}{4}^\circ$.

34 Face the exhaust valves to 45° and lap each valve into its respective seat, using suitable equipment.

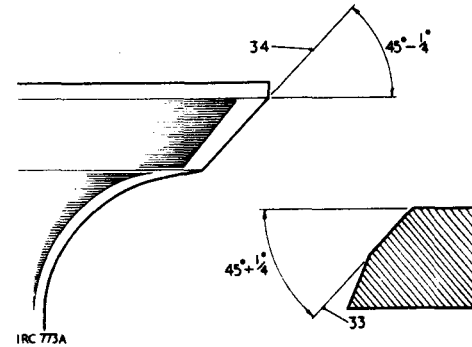

IRC 773A

35 Wash each valve, seat, port and guide in clean paraffin.

36 Lightly oil the valve stems and reverse 24.

37 If removed, reverse item 26, during which the valve timing must be re-set as necessary.

38 Reverse 20 and 21.

39 Refit the cylinder head. 12.29.10.

4 Remove the special nuts and sealing washers and lift off the top rocker cover and joint washer.

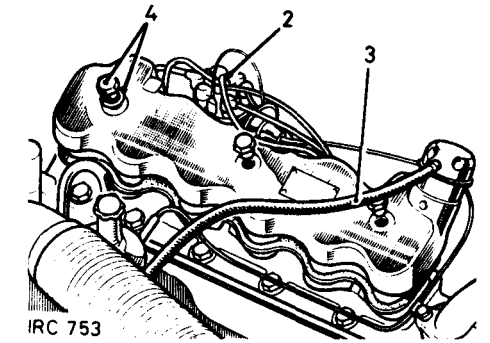

IRC 753

5 Slacken the locknuts and screw back the tappet adjusting screws.

6 Remove the nuts, washers and screw retainer plates from the rocker spacers.

7 Remove the special set screws and washers securing the rocker shafts.

8 Remove the end plug and sealing washer from the front of the cylinder head.

continued

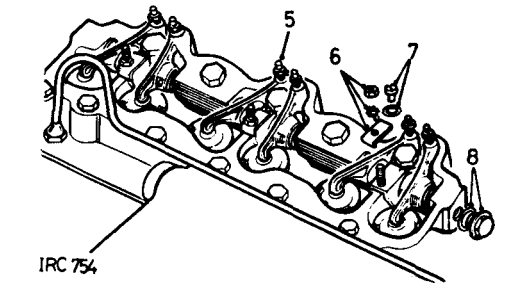

IRC 754

INLET VALVE ROCKERS AND SHAFTS

Remove and refit 12.29.35

Service tool: 262749 Extractor for rocker shafts

Removing

1 Remove the radiator and grille panel. 26.40.01.

2 Disconnect the sparking plugs leads and remove the distributor cap.

3 Disconnect the hose at the engine breather cap.

- 9 Extract the front and rear rocker shafts and withdraw the valve rockers, springs and spacers as they are released. Extractor 262749.

Refitting

- 10 Enter the rear (longer) shaft into the head, with the tapped holes aligned with the set screw holes in the housing webs, and with the oil holes facing away from the valves.
- 11 Push the shaft rearwards, fitting a spring, valve rocker, spacer, valve rocker and spring for each cylinder.

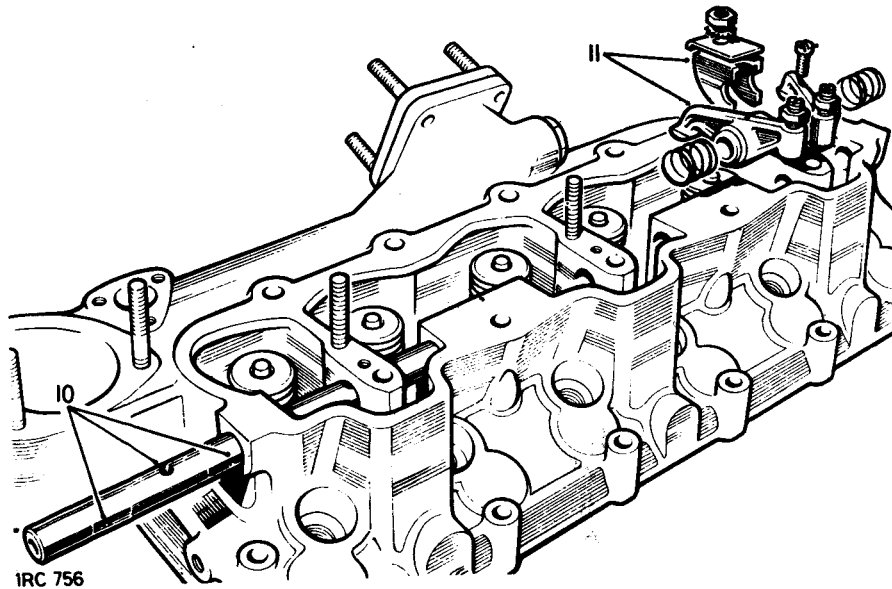
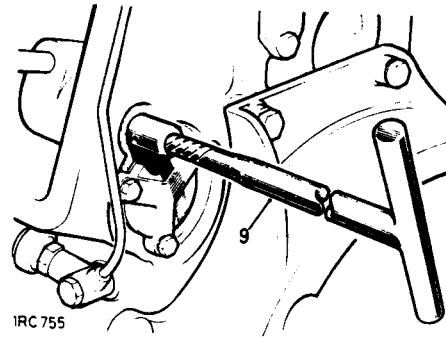

DATA

Inlet valve tappet clearance 0,15 mm (0.006 in.) with engine at normal running temperature.

- 12 Reverse 6 and 7 for the rear shaft.
- 13 Repeat 10 and 11 for the front (shorter) shaft.
- 14 Reverse 6 and 7 for the front shaft.
- 15 Set the tappet clearances to 0,15 mm (0.006 in.) in the following order:
Set No. 1 tappet with No. 6 valve fully open.
Set No. 2 tappet with No. 5 valve fully open.
Set No. 3 tappet with No. 4 valve fully open.
Set No. 4 tappet with No. 3 valve fully open.
Set No. 5 tappet with No. 2 valve fully open.
Set No. 6 tappet with No. 1 valve fully open.
- 16 Reverse 1 to 4.
- 17 Check the inlet valve tappet clearances with the engine at normal running temperature. Reset to 0,15 mm (0.006 in.) as necessary.

- 6 Remove the top rocker cover and slacken the inlet tappet adjusting screws.

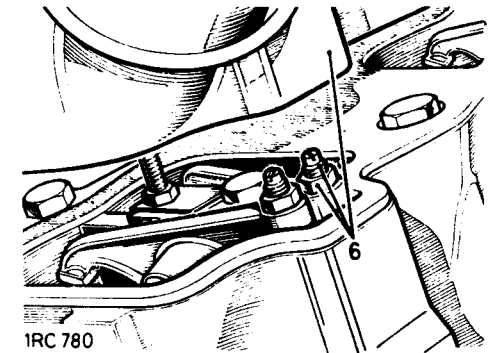

- 7 Remove the side rocker cover and slacken the exhaust tappet adjusting screws.
- 8 Remove the camshaft retaining plate and remove the end plug from the front end of the rocker shaft.

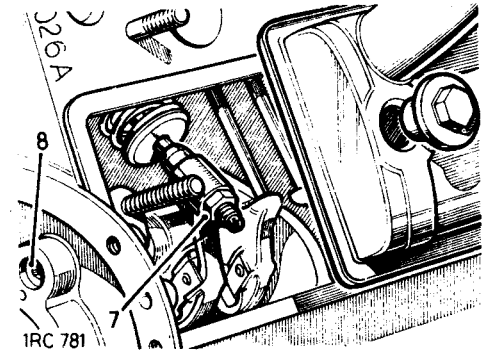

EXHAUST VALVE ROCKERS AND SHAFTS

Remove and refit 12.29.36

Service tool: 262749 Extractor for rocker shafts

Removing

- 1 Remove the radiator and grille panel. 26.40.01.
- 2 Remove the exhaust manifold. 30.15.10.
- 3 Remove the timing gear cover. 12.65.01.
- 4 Remove the timing chain tensioner. 12.65.28.
- 5 Remove the timing chain and gears. 12.65.12.

- 9 Remove the two locating screws securing front and rear rocker shafts.
- 10 Remove the oil feed bolt locating the distributor housing.

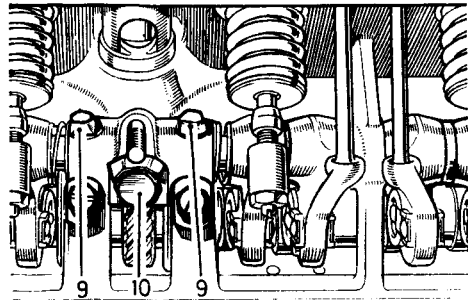

IRC782

- 11 Engage the extractor 262749 into the front rocker shaft.

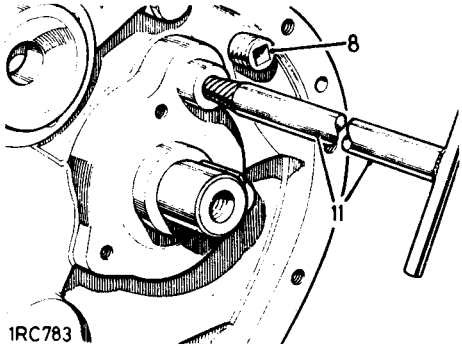

IRC783

- 12 Withdraw the rocker shaft.
- 13 Lift out the exhaust valve rockers, inlet cam followers, springs and spacers. Note the sequence of assembly.
- 14 Repeat 11 and 12 on the rear rocker shaft arrangement.

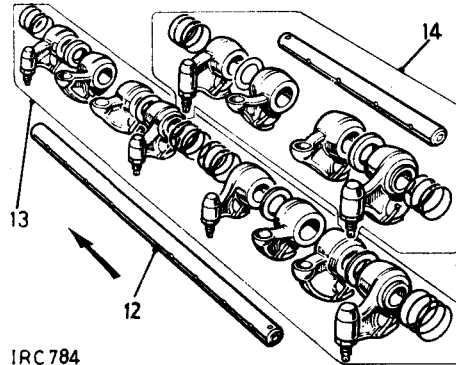

IRC784

Refitting

- 15 Fit a suitable slave bolt and packing washer into the tapped hole at front end of camshaft. This will enable the camshaft to be rotated as required to position the cam lobes away from the rocker assembly being fitted.
- 16 To aid reassembly, lay out the six spacer washers to be fitted between the inlet cam followers and exhaust valve rockers as follows:
Thick, thin, medium, medium, thin, thick.
- 17 Reverse 14 in the order removed, noting the fitted positions of the spacing washers. Items 18 to 20.
- 18 Thick washers.
- 19 Medium washers.
- 20 Thin washers.

- 21 Feed in the rear rocker shaft. Ensure that the locating screw hole in the shaft is to the front; use the extractor tool to align the hole with the hole in the block.
- 22 Secure the shaft with the locating screw and lock washer.
- 23 Reverse 12 and 13 in the order removed.
- 24 Feed in the front rocker shaft. Ensure the locating screw hole in the shaft is to the rear and in line with the hole in the block.

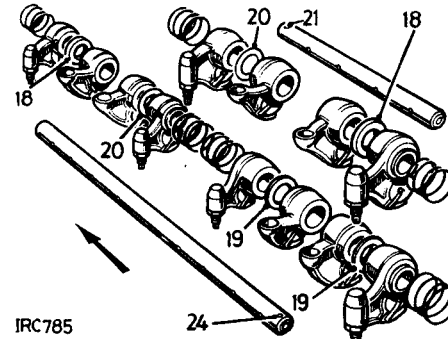

IRC785

- 25 Reverse 8 and 9.
- 26 Reverse 3, 4 and 5 setting the valve timing as described.
- 27 Set the tappet clearances to 0,15 mm (0.006 in.) for inlet valves and 0,25 mm (0.010 in.) for exhaust valves in the following order:
Set No. 1 tappet with No. 6 valve fully open.
Set No. 2 tappet with No. 5 valve fully open.
Set No. 3 tappet with No. 4 valve fully open.
Set No. 4 tappet with No. 3 valve fully open.
Set No. 5 tappet with No. 2 valve fully open.
Set No. 6 tappet with No. 1 valve fully open.
- 28 Reverse 1 and 2 and fit the rocker covers.
- 29 Check, and if necessary, reset the inlet valves tappet clearances with the engine at normal running temperature.

DATA

Tappet clearances:

Inlet	0,15 mm (0.006 in.).
Exhaust	0.25 mm (0.010 in.).

0,15 mm (0.006 in.).
0.25 mm (0.010 in.).

INLET VALVE ROCKERS

Replace Bush

12.29.55

Replacing bush

- 1 Remove the rockers and shafts. 12.29.35.
- 2 Press out the bush from the rocker.

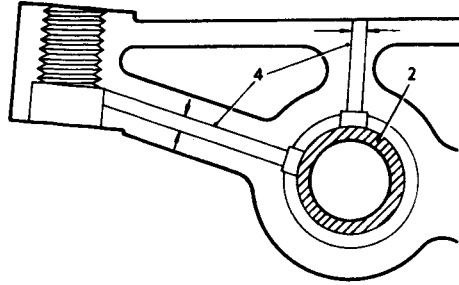

IRC 222B

- 3 Press in the replacement bush to 0,25 mm to 0,50 mm (0.010 in. to 0.020 in.) below the thrust face of the rocker.

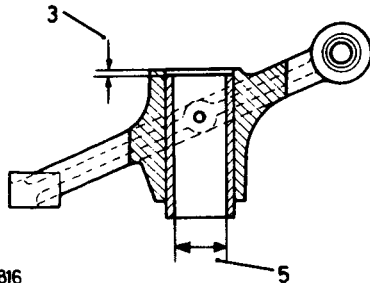

IRC 816

- 4 Using the holes in the rocker as guides, drill oil holes 1,58 mm (0.062 in.) and 2,77 mm (0.109 in.) diameter in the bush.
- 5 Ream the bush to 12,5 mm + 0,025 mm (0.500 in. + 0.001 in.).
- 6 Reverse 1.

ENGINE ASSEMBLY

Remove and refit

12.41.01

Removing

- 1 Remove the bonnet. 76.16.01.
- 2 Disconnect the battery earth lead.
- 3 Remove the radiator and grille panel. 26.40.01.
- 4 Remove the gearbox tunnel cover. 76.25.07.
- 5 Disconnect the front exhaust pipe from the manifold.
- 6 Remove the exhaust heat shield.
- 7 Disconnect the starter lead at the solenoid.
- 8 Disconnect the oil pressure and water temperature wires from the multi-plug on the main harness by the clutch pedal box, remove from the clip and release the harness clip from the air pipe.
- 9 Disconnect the engine earth cable at the chassis side-member.
- 10 Where fitted, disconnect the heater hoses.
- 11 Where fitted, disconnect the control cable at the heater water valve.
- 12 Disconnect the switch lead and HT lead at the ignition coil.
- 13 Disconnect the fuel feed at the filter.
- 14 Release the accelerator return spring.
- 15 Disconnect the accelerator linkage at the spring loaded bell crank lever.
- 16 Remove the fixings securing the clutch hose and speedometer cable bracket at the flywheel housing.
- 17 Disconnect the cold start control cables at the carburetter.
- 18 Detach the servo hose at the manifold pipe.
- 19 Remove the alternator lead from the solenoid.
- 20 Untape and remove the white wire from the throttle jack.
- 21 Remove the ignition coil from the bulkhead.

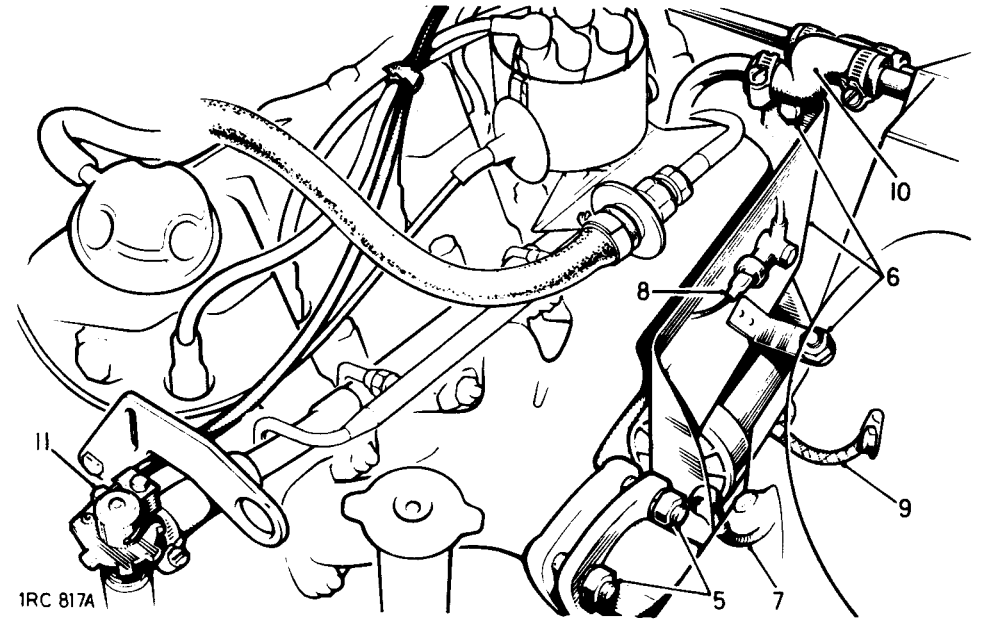

IRC 817A

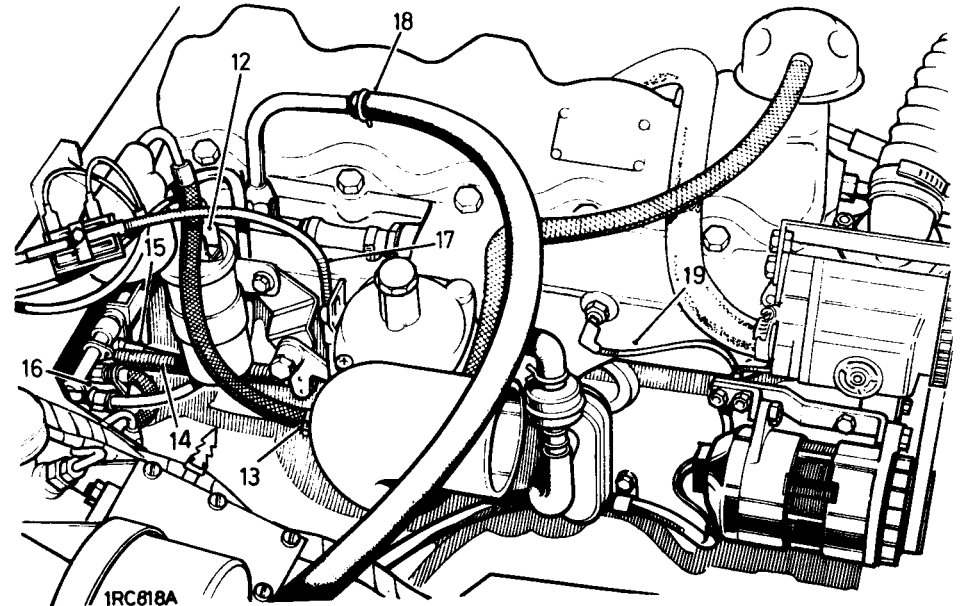

IRC818A

- 22 Support the engine weight, using a suitable lifting sling.
- 23 Remove the engine front mountings upper and lower fixings.
- 24 Support the gearbox, using suitable packing blocks or a jack, and remove the bell housing to flywheel housing fixings.
- 25 Pull the engine forward sufficient to disengage the drive from the gearbox.

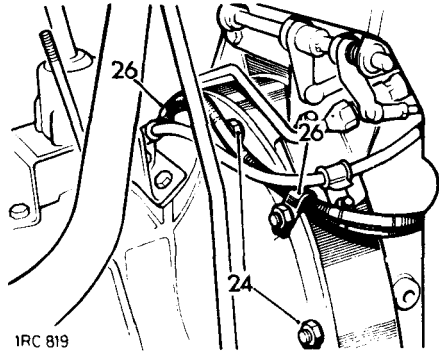

IRC 819

- 26 Ensure that all cables, pipes etc. are clear then hoist the engine from the vehicle.

Refitting

- 27 Smear the splines of the primary pinion, the clutch centre and the withdrawal unit abutment faces with Molybdenum disulphide grease such as Rocol MTS 1000.
- 28 Engage a gear to prevent gearshaft rotation and offer the engine to the gearbox. If necessary, rotate the engine sufficient to align the gearbox primary pinion with the clutch plate splines.
- 29 When aligned, push the engine fully to the rear and secure the bell housing to the flywheel housing, tightening the fixings evenly.
- 30 Lift the engine sufficient to remove the packing or jack from beneath the gearbox and insert the engine front mounting rubbers.
- 31 Reverse 1 to 23.

FLYWHEEL

Remove and refit 12.53.07

Removing

- 1 Remove the front floor. 76.10.12.
- 2 Remove the seat base. 76.70.06.
- 3 Remove the engine assembly. 12.41.01.
- 4 Remove the clutch assembly. 33.10.01.
- 5 Remove the flywheel.

Refitting

- 6 Fit the flywheel to the crankshaft and tighten the securing bolts. Torque: 8,5 to 9,0 kgf. m (60 to 65 lbf. ft.).
- 7 Mount a dial test indicator to read off the flywheel face.
- 8 Check the run-out on the flywheel face, this must not exceed 0,05 mm (0.002 in.).
- 9 If the run-out is excessive, remove the flywheel and investigate the cause.
- 10 Reverse 1 to 4.

FLYWHEEL

Overhaul 12.53.10

Procedure

Wear or scoring on the flywheel pressure face may be corrected by machining, providing that the overall thickness of the flywheel is not reduced below 30,5 mm (1.204 in.).

- 1 Remove the flywheel. 12.53.07.
- 2 Check the overall thickness of the flywheel, as it may have been previously machined.
- 3 If the flywheel is above the minimum thickness, the clutch face can be refaced as follows:
- 4 Remove the dowels.
- 5 Reface the flywheel over the complete surface.
- 6 Check the overall thickness of the flywheel to ensure that it is still above the minimum thickness.
- 7 Fit the dowels.
- 8 Refit the flywheel. 12.53.07.

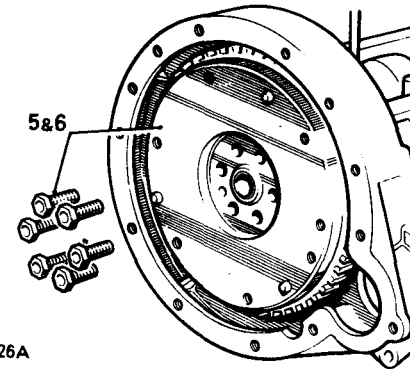

IRC 826A

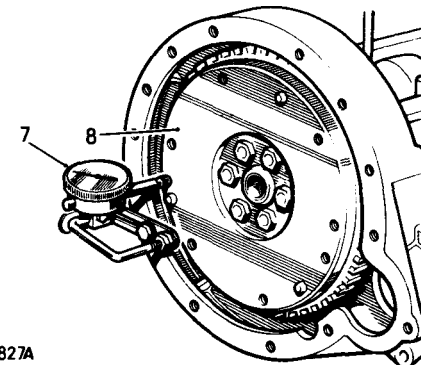

IRC 827A

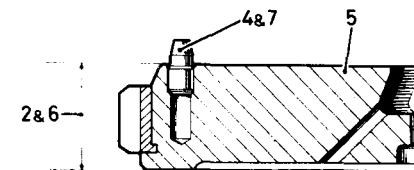

IRC 829

STARTER RING GEAR

Remove and refit 12.53.19

Removing

- 1 Remove the flywheel. 12.53.07.
- 2 Drill an 8 mm (0.312 in.) diameter hole axially between the root of any tooth and the inner diameter of the starter ring sufficiently deep to weaken the ring. DO NOT allow the drill to enter the flywheel.
- 3 Secure the flywheel in a vice fitted with soft jaws.
- 4 Place a cloth over the flywheel to protect the operator from fragments.

WARNING: Take adequate precautions against fragments as the starter ring may break asunder when being split.

- 5 Place a chisel immediately above the drilled hole and strike it sharply to split the starter ring.

Refitting

- 6 Heat the starter ring gear uniformly to between 225° C and 250° C (437° F and 482° F) but do not exceed the higher temperature.
- 7 Place the flywheel, flanged side down, on a flat surface.
- 8 Locate the heated starter ring gear in position on the flywheel with the square edge of the teeth against the flywheel flange.

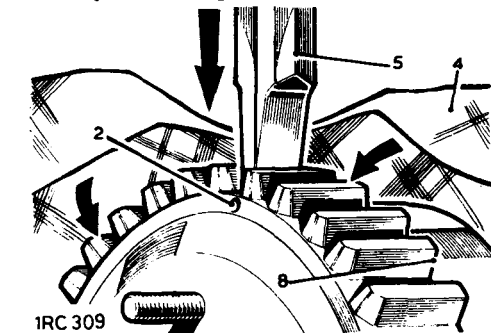

IRC 309

- 9 Press the starter ring gear firmly against the flange until the ring contracts sufficiently to grip the flywheel.
- 10 Allow the flywheel to cool gradually. DO NOT hasten cooling in any way.
- 11 Refit the flywheel. 12.53.07.

SPIGOT BEARING

Remove and refit 12.53.20

Removing

- 1 Remove the flywheel. 12.53.07
- 2 Press the spigot bearing from the flywheel.

Refitting

- 3 Press in the new spigot bearing flush with the clutch side of the flywheel.
- 4 Ream the spigot bearing to 22,237 mm to 22,242 mm (0.8755 in. to 0.8757 in.).
- 5 Refit the flywheel. 12.53.07.

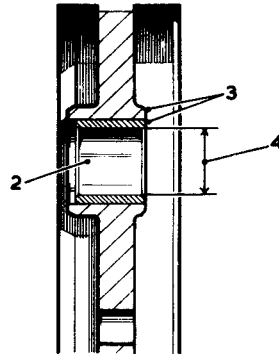

IRC 311

OIL FILTER ASSEMBLY, EXTERNAL

Remove and refit 12.60.01

Removing

- 1 Remove the fixings, oil filter adaptor to cylinder block.
- 2 Withdraw the oil filter assembly complete with adaptor.
- 3 Withdraw the front and rear joint washers.
- 4 If required, remove the fixings and detach the filter body from the adaptor; withdraw the joint washer.

Refitting

- 5 Reverse 4 as necessary. Torque 3,45 kgf m (25 lbf ft).
- 6 Reverse 1 to 3.
- 7 Replenish the lubricating oil as necessary.

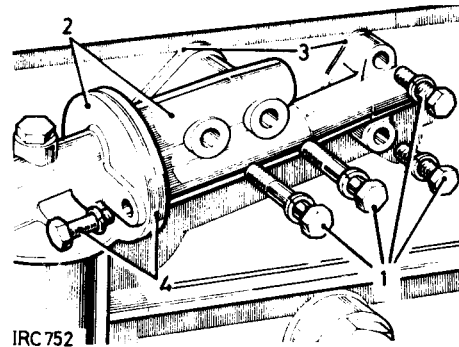

IRC 752

OIL STRAINER

Remove and refit 12.60.20

Removing

- 1 Remove the oil sump. 12.60.44.
- 2 Remove the strainer fixings.
- 3 Withdraw the strainer from the oil pump.

Refitting

- 4 Wash the strainer, using clean fuel.
- 5 Reverse 1 to 3.

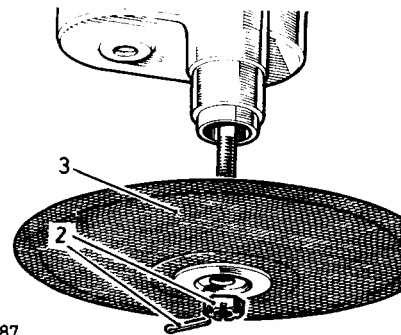

IRC 787

OIL PUMP

Remove and refit 12.60.26

Removing

- 1 Remove the oil sump. 12.60.44.
- 2 Remove the relief valve retainer and joint washer.

NOTE: Take care to retain the steel ball which is freed from the oil pump relief outlet.

- 3 Withdraw the spring and plunger.
- 4 Remove the oil pump locating screw.
- 5 Withdraw the oil pump and strainer assembly from the engine.

Refitting

- 6 Offer the oil pump assembly to the engine and align the pressure relief valve housing and the locating screw bore with the respective tappings in the engine block.
- 7 Reverse 1 to 5.

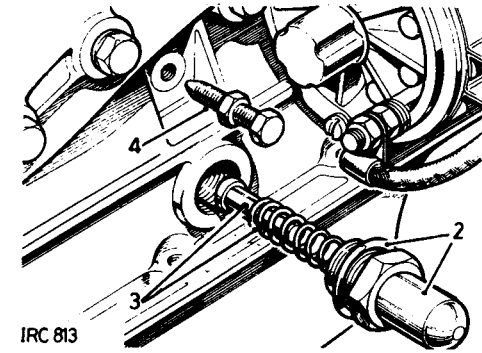

IRC 813

OIL PUMP

Overhaul 12.60.32

Dismantling

- 1 Remove the oil pump. 12.60.26.
- 2 Remove the oil pump strainer.
- 3 Remove the oil pump body.
- 4 Lift out the pump gears.

Inspecting and replacement

- 5 Clean all parts and examine for wear.
- 6 If required, unscrew and replace the idler gear spindle in the pump cover.
- 7 If required, replace the drive shaft bush at the top of the pump body. Press the replacement bush into the body and ream in position to 14,28 mm + 0,02 mm (0.5625 in. + 0.001 in.). Ensure correct alignment with the bore at the bottom end of the pump body; the bush should be a light drive fit.

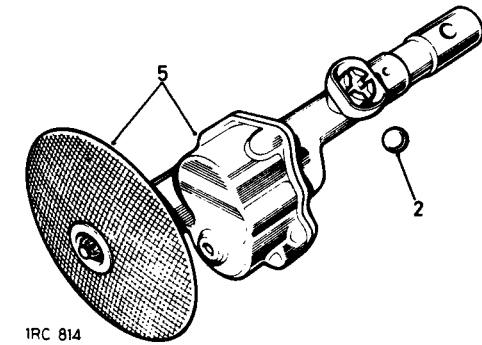

IRC 814

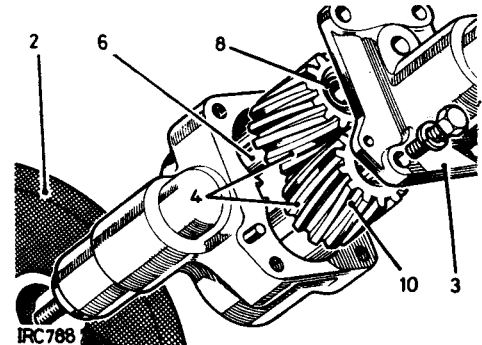

IRC 788

- 8 If required, replace the bush in the idler gear. Drill the oilway 3,0 mm (0.125 in.) diameter then ream the bush, in position, to 12,7 mm + 0,02 mm (0.500 in. + 0.001 in.) in diameter.
- 9 Fit the idler gear to the spindle.
- 10 Fit the driving gear with the plain part of the gear bore uppermost.
- 11 Using a straight edge and feeler gauges, check the gears end-float which should be:
 - Driving gear: 0,05 to 0,12 mm (0.002 to 0.005 in.).
 - Idler gear: 0,07 to 0,15 mm (0.003 to 0.006 in.).
- 12 Reverse 1 to 3.

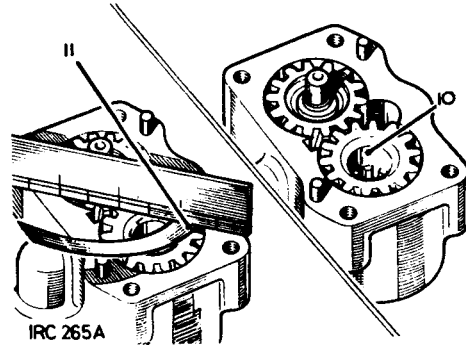

OIL SUMP

Remove and refit 12.60.44

Removing

- 1 Remove the sump plug and drain off the lubricating oil.
- 2 Withdraw the dipstick.
- 3 Remove the fixings at the sump flange.
- 4 Lower the sump to clear the oil strainer and withdraw.
- 5 Withdraw the sump joint washer.

Refitting

- 6 Reverse 4 and 5, using a new sump joint washer.
- 7 Reverse 3, fitting the two 5/16 in. UNC bolts into the timing gear cover tappings.
- 8 Reverse 1 and 2.
- 9 After 1600 km (1000 miles) running, recheck sump bolts for correct torque as follows:
- 10 Slacken each bolt in turn approximately one flat, then retighten to 1,65 kgf m (12 lbf ft).

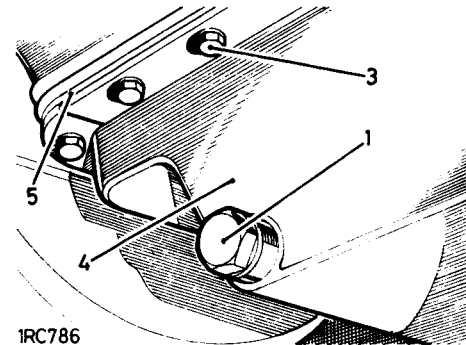

TIMING GEAR COVER AND OIL SEAL

Remove and refit
 Gear cover 1 to 9 12.65.01
 Oil seal 12.65.05

Service tool: 530102 Spanner for starter dog

NOTE: On initial assembly of the engine, the mud shield around the oil seal is rivetted in position but after removal in service the rivets are substituted with self tapping drive screws. Where drive screws are fitted, it may be possible to renew the seal without removing the timing gear cover.

AT 7, if the mud shield is fitted with drive screws, the screws may be removed and the oil seal extracted.

On fitting a new seal, the mud shield should be allowed to finally pull the seal into position to ensure a positive location.

Removing

- 1 Remove the bonnet. 76.16.01.
- 2 Remove the fan blades and radiator front panel assembly. 26.40.01.
- 3 Slacken the air pump fixings and remove the drive belt.
- 4 Slacken the alternator fixings and remove the fan belt.

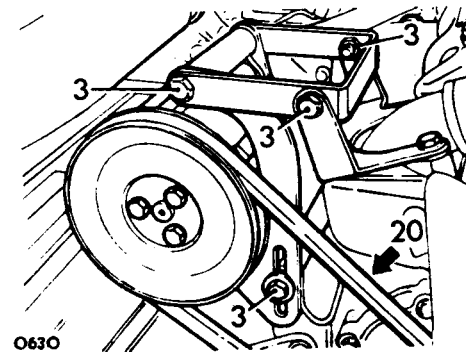

- 5 Remove the alternator adjusting link.
- 6 Remove the starter dog using 530102.
- 7 Withdraw the crankshaft pulley. At this point, see note above and if the mud shield is rivetted:
- 8 Remove the timing cover fixings, including those at the sump front face.
- 9 Taking care not to damage the sump joint, carefully withdraw the timing cover and gasket.

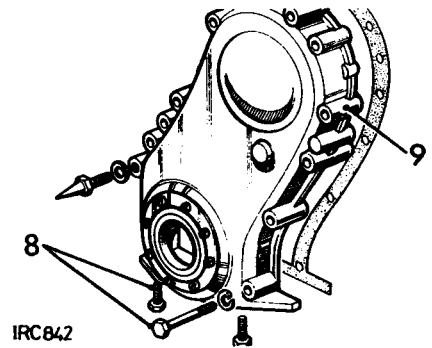

- 10 Drill out the rivets securing the oil seal mud shield.
- 11 Press out the oil seal and clean the mating surfaces.
- 12 Smear the outside diameter of a new oil seal with Hylomar PI 32/M jointing compound.
- 13 Press the oil seal into the timing cover.
- 14 Coat the drive screws with Hylomar and fit and secure the mud shield.

continued

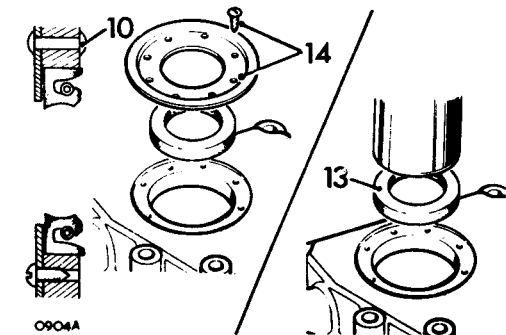

Refitting

- 15 Smear general purpose grease on both sides of the cover joint washer.
- 16 Reposition the cover on the engine and refit the fixings.
- 17 Fit the starter dog. Torque: 27,65 kgf. m (200 lbf. ft.).

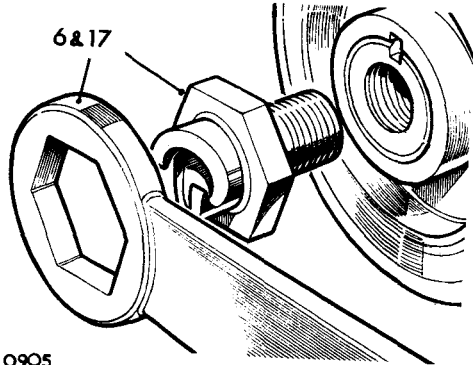

0905

- 18 Fit the alternator adjusting link.
- 19 Refit the fan belt and adjust.
- 20 Refit the air pump drive belt and adjust.
- 21 Reverse 1 to 3.

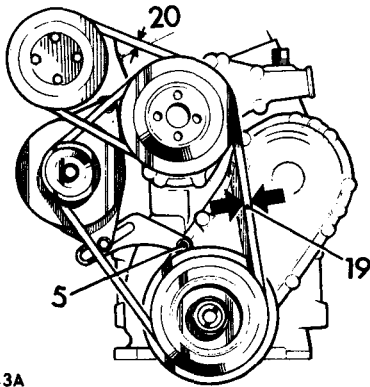

IRC 843A

TIMING CHAIN GEARS

Remove and refit

12.65.12

Service tool: 507231 Extractor for chain-wheel

Removing

- 1 Remove the radiator and front panel. 26.40.01.
- 2 Remove the timing gear cover. 12.65.01.
- 3 Remove the timing chain tensioner. 12.65.28.
- 4 Remove the camshaft chainwheel fixings.
- 5 Extract the camshaft chainwheel, using 507231, together with the crankshaft chainwheel.
- 6 Withdraw the chain from the chainwheels.
- 7 Replace the chain vibration damper if the rubber facing is worn.

Refitting, including valve timing procedure

- 8 Temporarily fit the timing gear cover, using fixings sufficient to retain it on the dowels.
- 9 Fit the timing pointer to the cover.
- 10 Temporarily fit the pulley to the crankshaft, engaging the keyway and key.
- 11 Rotate the crankshaft to align the TDC mark on the pulley with the timing pointer.

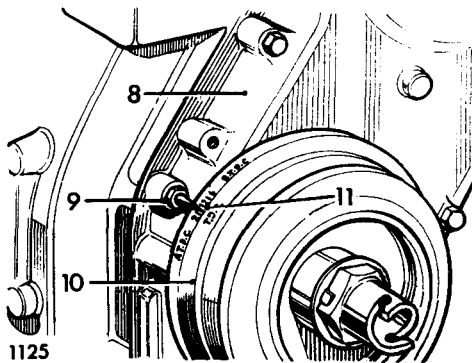

1125

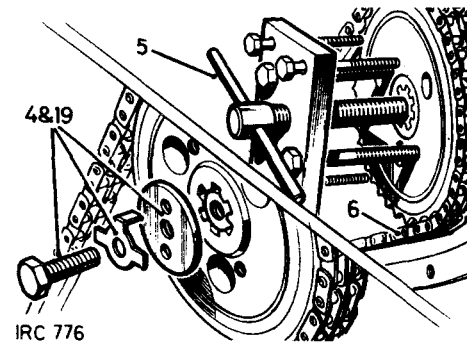

IRC 776

- 12 Remove the crankshaft pulley and timing gear cover without disturbing the crankshaft position.
- 13 Temporarily fit the camshaft chainwheel, engaging the keyway marked 'P'.
- 14 Rotate the camshaft to position the groove marked 'A' in line with the centre line of the top fixing hole for the gear cover. Remove the chainwheel without disturbing the camshaft position.
- 15 Fit the crankshaft chainwheel, chamfered bore first, to just engage the crankshaft inner key.

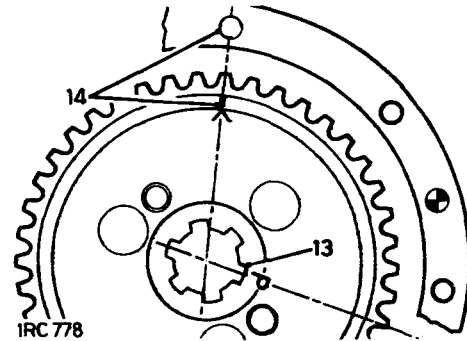

IRC 778

DATA

Clearance, timing chain to chain vibration damper

- 16 Position the chain on the chainwheels, aligning the keyway 'P' with the camshaft key and with 'no slack' at the driving side of the chain.
- 17 Fit the camshaft chainwheel and chain.
- 18 Lightly tap home the chainwheels.

NOTE: It is important that the timing chain has no slack at the driving side. Slightly offset keyways are provided in the camshaft chainwheel to enable adjustment to be made, if required, provided that the crankshaft and camshaft relationship is not disturbed.

- 19 Fit and lock the camshaft chainwheel fixings.
- 20 If required, adjust the chain vibration damper position to allow 0,05 mm to 0,25 mm (0.002 in. to 0.010 in.) clearance with the chain.
- 21 Reverse 2 and 3. Torque load for starting dog fixing is 27,5 kgf. m (200 lbf. ft.).
- 22 Reverse 1.

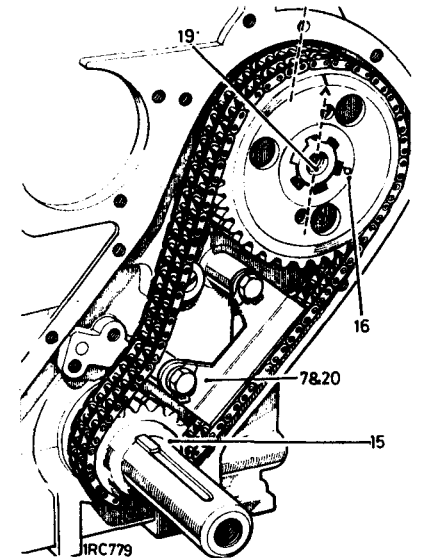

IRC 779

0,05 mm to 0,25 mm (0.002 in. to 0.010 in.)

TIMING CHAIN TENSIONER

Remove and refit 12.65.28

Removing

- 1 Remove the radiator and front panel. 26.40.01.
- 2 Remove the timing gear cover. 12.65.01.
- 3 Remove the tensioner retaining bolts and spring washers.
- 4 Remove the tensioner and backplate between the tensioner body and cylinder block.

Dismantling

- 5 Press in the slipper and remove it from the tensioner body.
- 6 Remove the ratchet and spring.

Examination

- 7 Check the slipper pad for wear, and renew if necessary.
- 8 Examine the ratchet for wear and renew if suspect.
- 9 Check the spring and renew if broken or suspect.
- 10 Examine the tensioner body and check that the oil inlet hole is clear.

Reassembling

- 11 Insert the spring into the slipper bore.
- 12 Fit the ratchet into the bore and turn clockwise with an Allen Key to lock it in a retracted position.
- 13 Fit the slipper assembly to the tensioner body.

NOTE: To prevent the tensioner releasing while fitting, insert a spacer between the tensioner body and the back of the slipper.

- 14 Fit the tensioner assembly and backplate to the cylinder block taking care not to allow the tensioner to release. Secure with the two bolts and spring washers.
- 15 Ensure correct location of the chain guide.
- 16 Reverse 1 and 2.

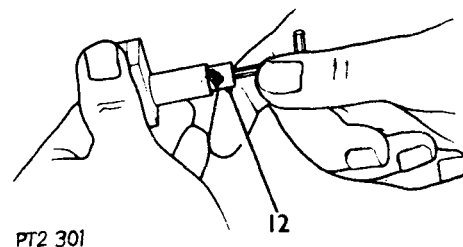
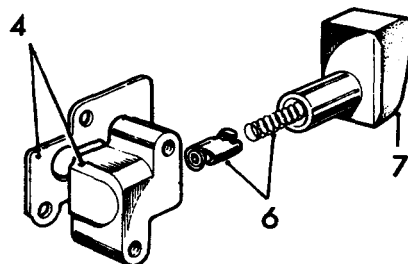
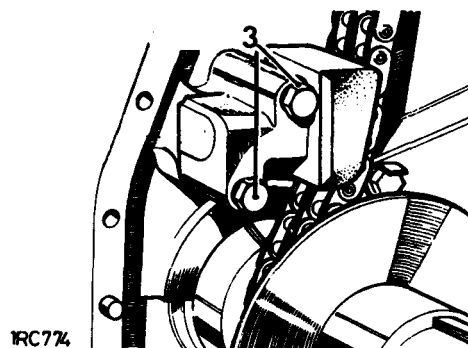

EMISSION AND EVAPORATION CONTROL SYSTEM

Introduction

17.00.00

Land Rover models are equipped with emission control features designed to comply with all current regulations for the particular sales market; however, due to varying regulations between different countries all of the features described may not be applicable to or incorporated on a particular model.

Three independent and separate systems are employed for emission control, namely crankcase emission control, evaporative loss control and exhaust emission control as described subsequently.

2½ litre Diesel

In certain countries, the exhaust gas emitted from Diesel engine vehicles must conform with smoke density regulations. Land Rover models supplied for these countries are tested during manufacture to ensure conformity with these regulations and, when satisfactory, a seal is attached to the fuel injection pump adjacent to the pump manufacturer's seal. In countries where the exhaust smoke density regulations apply, any work undertaken on Diesel engines or Diesel fuel systems which might influence the smoke density must be followed by the required tests in accordance with the current regulations.

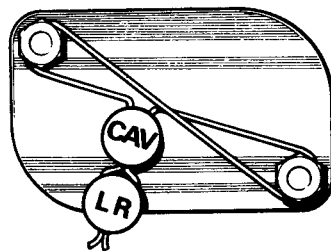

IRC 974

EMISSION SYSTEMS—FAULT DIAGNOSIS

The following symptoms indicate possible malfunction of the emission control devices fitted to the Land Rover:

- Violent backfire in exhaust system.
- Hesitation to accelerate on re-opening the throttle after throttle closure.
- Engine idles erratically or stalls.
- Engine misfire.
- Engine stops after short running periods (fuel starvation).
- Lack of power.
- High fuel consumption.
- Ignition warning light on above idle speed (slack or broken fan belt).
- Smell of fuel vapours.
- High temperature indicated (overheating of coolant).

Four basic visual checks, listed below, should be made initially.

- Drive belt condition and adjustment.
- All hoses for security, damage or deterioration.
- Fuel leakage and fuel filler cap for sealing.
- Oil filler cap for sealing.

If the symptom(s) persist(s), refer to the charts on the following pages for possible causes, checks and remedies.

SYMPTOM	POSSIBLE CAUSE	CHECK AND REMEDY
A—Difficult starting engine cold	Fuel starvation 1. Float chamber fuel level too low. 2. Choke butterfly not fully closing. 3. Throttle closed against throttle stop screw with choke butterfly closed. 4. Crankcase ventilation system. 5. Carburetter throttle prop lever jammed open.	(a) Check needle valve for sticking in seat. Clean as necessary to remove any deposits, using methylated spirits. (b) Check float level setting. Reset as necessary. (c) Blocked fuel filter. Renew as necessary. (d) Air leakage in crankcase emission control system. (a) Check for broken or detached spring on choke operating lever. Renew as necessary. (b) Friction between choke spindle bearings due to carbon deposits, or choke spindle distortion. Clean or renew as necessary. (c) Choke butterfly fouling in carburetter due to misalignment. Adjust as necessary. (d) Choke cable securing screw on lever swivel loose. Tighten securing screw with the choke control pushed fully in and the choke butterfly open. (a) With the choke butterfly closed, the throttle should be open slightly beyond the normal slow run position. Check for distortion of the interconnecting link between choke and throttle linkage. Adjust or renew as necessary. (a) Check as in H 1 (a). (b) Check as in E 5 (a).
B—Difficult starting engine hot	Mixture over-rich 1. Float chamber fuel level too high. 2. Internal leakage 3. Adsorption canister flooded. 4. Distributor. 5. Distributor condenser and ignition coil.	(a) Check float level setting. Reset as necessary. (b) Check for leakage past needle valve and seating. Check-tighten seating housing. (c) Check needle valve and seat size. Renew as necessary. (a) Check that sealing 'O' ring is present around venturi spigot and is sound. Renew as necessary. (a) Check air inlet for blockage. Renew adsorption canister. (a) Check as in C 6 (a). (a) Check as in J 5 (a).
C—Engine will not idle or run smoothly	1. Manifold bolts. 2. Cylinder head bolts. 3. Carburetter adjustment.	(a) Check inlet and exhaust manifold bolts for security. Tighten as necessary. (b) Check carburetter to manifold joint for air leaks. Renew gaskets and tighten carburetter fixings as necessary. (a) Check tightness of cylinder head bolts to specified torque figures. (a) Check carburetter slow running adjustment. Adjust as necessary.

SYMPTOM	POSSIBLE CAUSE	CHECK AND REMEDY	
C – cont.	4. Carburetter solenoid valve sticking closed.	(a) Check electrical feed lead is sound and terminals clean and secure. Renew lead as necessary. (b) Remove electrical lead at solenoid. With ignition switch 'ON', touch solenoid lead against the solenoid terminal connection. A 'click' will indicate that the valve is operating. If in doubt, proceed to (c) below. (c) Remove solenoid valve from carburetter. Switch ignition 'ON' and earth the solenoid valve body at a convenient point on the engine block. The solenoid valve spindle should withdraw into the valve body when energised. Where solenoid renewal is required, fit a new solenoid valve assembly complete.	
	5. Adsorption canister flooded.	(a) Check air inlet for blockage. Renew adsorption canister.	
	6. Distributor.	(a) Check condition of contact points. Reset gap to 0,35 to 0,40 mm. (0.014 to 0.016 in.). Renew contact points if badly burnt or pitted. (b) Check condition of distributor vacuum pipe and connections for leaks. Rectify as necessary.	
	7. Ignition leads and wiring.	(a) Inspect ignition leads for fraying, chafing or deterioration. Check Lucar connections and fixings for security. (b) Check high tension leads for security and corrosion. Renew as necessary.	
	8. Spark plugs.	(a) Check condition of spark plugs. If satisfactory reset gap to 0,75 to 0,80 mm (0.029 to 0.032 in.).	
	9. Crankcase ventilation system.	(a) Check as in H 1 (a).	
	D—Engine 'runs on' after ignition switched 'OFF'	1. Carburetter solenoid valve sticking open.	(a) Check as in C 4 (b). (b) Remove solenoid valve from carburetter. Check valve is free to return under its spring loading with the solenoid de-energised. Where solenoid renewal is required, fit a new solenoid valve assembly complete. (c) If the solenoid valve functions correctly, check valve seat in carburetter for foreign matter which could prevent the valve from seating correctly.
		2. Ignition timing.	(a) Check in E3 (a).
	E—Erratic slow running and stalling	Partial fuel starvation	(a) Check as in A 1 (a). (b) Check slow-run jet, slow-run fuel passages and slow-run air intake orifice for obstruction. Clean as necessary, take care not to alter jet or orifice sizes. (c) Check idle volume control outlet hole for obstruction. Clean as in (b) above. (d) Check volume control (mixture) screw conical end is not worn or malformed. Check screw locknut is sound and effectively retains screw in position when fitted. Renew as necessary.
1. Fuel passages or jets obstructed.		(a) Check as in C 3 (a).	
	2. Carburetter adjustment.		

SYMPTOM	POSSIBLE CAUSE	CHECK AND REMEDY	
E — cont.	3. Distributor.	(a) Check ignition timing using electronic equipment. Adjust if necessary. (b) Check as in C 6 (b). (c) Check distributor advance and retard mechanism using electronic equipment. Rectify as necessary.	
	4. Crankcase ventilation system. Sudden increase in engine idling speed	(a) Check as in H 1 (a).	
	5. Carburetter throttle prop lever.	(a) Check that the carburetter throttle prop lever has not jammed in the open position due to foreign matter on the lever spindle. Clean off foreign matter and check operation.	
	6. Carburetter vacuum unit or	(a) Disconnect the pipe between the trigger valve and carburetter vacuum unit. If engine idle speed does not decrease immediately, the vacuum unit is faulty. Renew the vacuum unit.	
	7. Valve clearances or trigger valve (Excessive valve clearance will give increased idling vacuum).	(b) Check inlet and exhaust valve clearances. Set to 0,25 mm (0.010 in.), engine hot. Recheck engine idling speed. If idling speed has not decreased, fault lies within the trigger valve. Renew trigger valve.	
	F—Excessive fuel consumption (Smell of fuel vapours)	1. Choke butterfly not in fully open position during normal running.	(a) Check linkage from dash panel control to carburetter. Re-set choke cable as necessary.
		2. Economy device not functioning correctly.	(a) Check-tighten diaphragm cover fixing screws. (b) Check condition of diaphragm and gaskets. Renew as necessary. If renewing diaphragm, also fit new diaphragm spring.
3. Needle valve and seating leaking or oversize.		(a) Check and remedy as under B 1 (b) and (c).	
4. Plunger sticking in on throttle controlled vacuum switch.		(a) Renew switch.	
5. Float chamber leaking.		(a) Check for fuel leakage from float chamber. Renew gasket if necessary.	
6. Fuel system.		(a) Check all fuel pipes, joints and connections for leaks. Rectify as necessary.	
7. Adsorption canister flooded.		(a) Check air inlet for blockage. Renew adsorption canister.	
G—Poor acceleration	1. Accelerator linkage.	(a) Check for correct operation of accelerator linkage between pedal and carburetter. Lubricate and rectify as necessary.	
	Partial fuel starvation		
	2. Accelerator pump sticking.	(a) Check piston assembly moves freely in its housing bore and will fully return under the spring loading. Clean piston bore also clean non-return valve and seating at base of pump housing bore.	
	3. Accelerator pump jet and orifice blockage.	(a) Check pump jet is not obstructed. Clean as necessary. (b) Ensure 'progression' holes in throttle bore adjacent to throttle edge are clear and not obstructed. Clean as necessary, do not enlarge holes. (c) Ensure economy diaphragm assembly is sound. Renew as necessary.	

SYMPTOM	POSSIBLE CAUSE	CHECK AND REMEDY
G – cont.	4. Plunger sticking in on throttle-controlled vacuum switch. 5. Fuel passages or jets obstructed. 6. Fuel filter.	(a) Renew switch. (a) Check as in E 1 (a), (b), (c) and (d). (a) Check fuel filter for blockage. Renew as necessary.
H—Loss of power	1. Crankcase ventilation system. 2. Air cleaner. 3. Carburetter fuel passages obstructed. 4. Throttle not fully opening. 5. Distributor. 6. Spark plugs. 7. Inlet and exhaust valves.	(a) Check for blockage or deterioration and security of hoses and oil filler cap, also hoses on the carburetter throttle prop system. Renew any hose as necessary. (a) Check air cleaner filter for blockage. Clean the filter in petrol and renew the oil in the bowl. (a) Check emulsion block jets and passages for obstruction. Clean as necessary. Note: Do not fit larger jets to this carburetter otherwise exhaust emission regulations will be contravened. (a) Check linkage from accelerator to carburetter. (a) Check as in C 6 (a) and (b). (b) Check as in E 3 (a) and (c). (a) Check as in C 8 (a). (a) Check as in G 9 (a).
J—Engine misfire	Partial fuel starvation 1. Float chamber fuel level too low 2. Fuel passages or jets obstructed. 3. Spark plugs. 4. Distributor. 5. Distributor condenser and coil. 6. Ignition wiring. 7. Inlet and exhaust valves.	(a) Check as in A 1 (a), (b), (c) and (d). (a) Check as in E 1 (b), (c) and (d). (a) Check as in C 8 (a). (a) Check as in C 6 (a). (a) Check with suitable electronic equipment for an electrical break-down on either the ignition coil or condenser. Renew as necessary. (a) Check as in C 7 (a) and (b). (a) Check as in G 9 (a).
K—Backfire in exhaust system	1. Weak mixture. 2. Crankcase ventilation system. 3. Carburetter mixture 4. Exhaust system. 5. Ignition timing.	(a) Check inlet manifold bolts for security. Tighten as necessary. (b) Check carburetter to manifold joint for air leaks. Renew gaskets and tighten carburetter fixings as necessary. (a) Check as in H 1 (a). (a) Check as in C 3 (a). (a) Check exhaust system for leaks. Renew components as necessary. (a) Check as in E 3 (a), (b) and (c).

CRANKCASE BREATHING SYSTEMS

Description 17.10.00
 2½ litre Europe (Prior to October 1977) Fig. 2
 2½ litre Australia Fig. 1

Fig. 1 Crankcase Breathing System—Australia

The 'blow-by' gases from the crankcase are vented into the combustion system to be burnt with the fuel/air mixture. This system provides positive emission control under all conditions. During engine running, crankcase fumes which may collect in the crankcase are vented to the carburettor and clean air is admitted through the top cover breather to assist in purging.

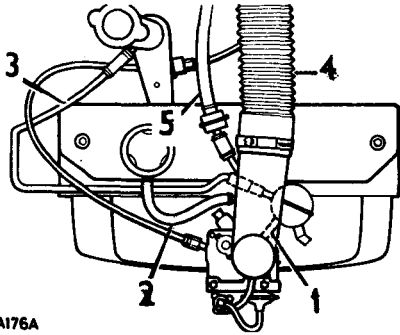

IRA176A

- 1 Hose—non return valve to carburettor.
- 2 Hose—top cover breather to air cleaner elbow.
- 3 Hose—oil filler to non return valve.
- 4 Hose—air cleaner to carburettor.
- 5 Hose—adsorption canister to air cleaner elbow.

Fig. 2 Crankcase Breathing System—Europe

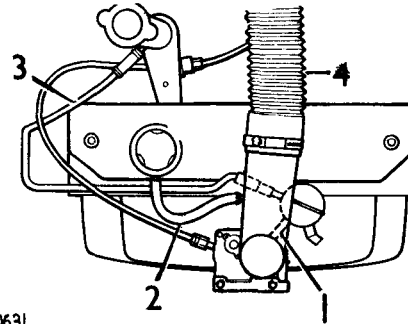

0631

- 1 Hose—non return valve to carburettor.
- 2 Hose—top cover breather to air cleaner elbow.
- 3 Hose—oil filler to non return valve.
- 4 Hose—air cleaner to carburettor.

Fig. 3 Crankcase Breathing System—Europe

2½ litre Europe (After October 1977)

Blow-by gases are vented to the intake system by connecting the top cover breather to the air intake elbow and carburettor adaptor.

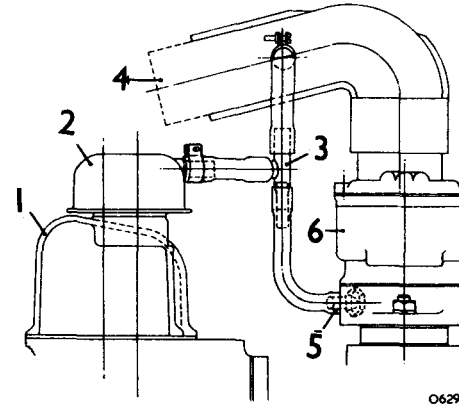

0629

- 1 Rocker cover.
- 2 Breather assembly.
- 3 Tee-piece.
- 4 Air intake.
- 5 Carburettor adaptor.
- 6 Carburettor.

Fig. 4 Crankcase Breathing System—2.6 litre Europe

Crankcase breathing and evacuation of 'blow-by' gases is achieved by utilizing the characteristic partial vacuum in the constant depression carburettor. By this method, crankcase emissions are burned in the engine combustion process.

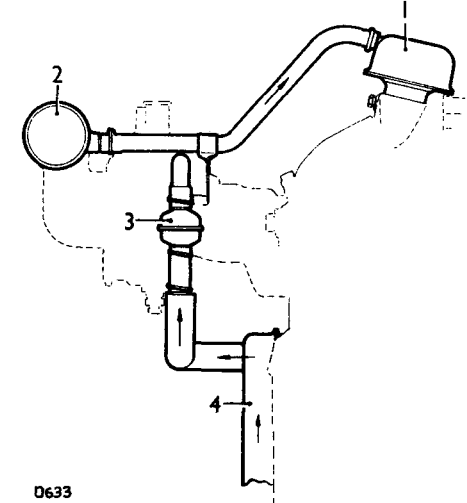

0633

- 1 Breather assembly.
- 2 Air intake.
- 3 Flame trap.
- 4 Crankcase breather cover.

ENGINE BREATHER FILTER

Remove and refit 17.10.02

Removing

- 1 Disconnect the breather hose.
- 2 Remove the securing bolt.
- 3 Remove the filter.
- 4 Remove the sealing ring.
- 5 Wash the gauze thoroughly by swilling the unit in petrol.
- 6 Re-wet the gauze by dipping it in clean oil and shake off the surplus.

Refitting

- 7 Reverse 1 to 4 above.

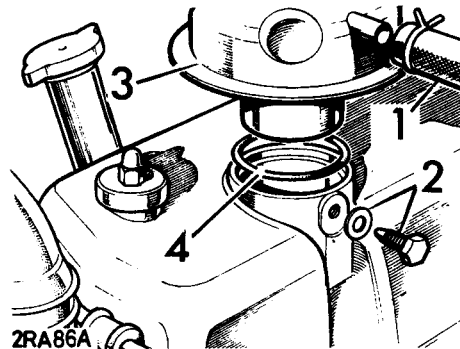

FLAME TRAP

Remove and refit 17.10.03

- 1 Detach the rubber hose from each side of the flame trap by releasing the clips.
- 2 Withdraw the flame trap (1).
- 3 Fit a new flame trap and secure the clips.

Flame trap—2½ litre Australia

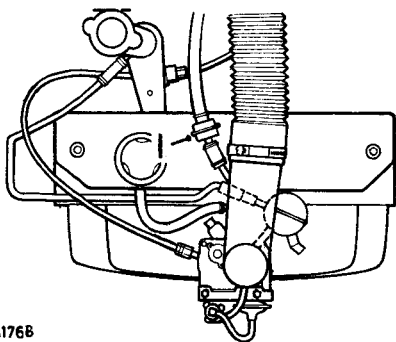

Flame trap—2.6 litre Europe

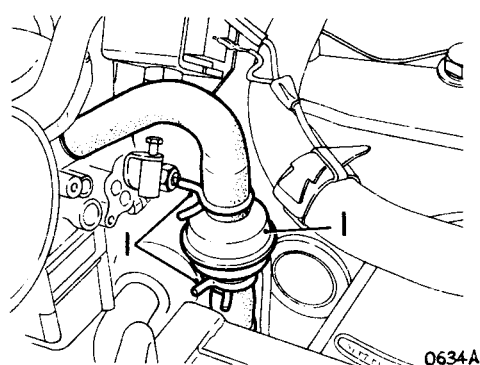

CRANKCASE EMISSION VALVE

Remove and refit 17.10.09

Removing

- 1 Disconnect the inlet hose.
- 2 Disconnect the outlet hose.
- 3 Remove the fixings.
- 4 Withdraw the valve unit.

Refitting

- 5 Reverse 1 to 4.

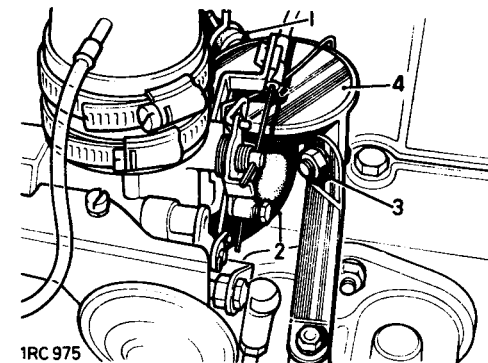

CRANKCASE EMISSION VALVE

Overhaul 17.10.15

Dismantling

- 1 Remove the valve. 17.10.09.
- 2 Remove the spring clip retaining the cover.
- 3 Remove the cover.
- 4 Remove the diaphragm unit complete with orifice plunger.
- 5 Remove the diaphragm spring.
- 6 Clean orifices, control body and the cover in methylated spirits. (Ethanol).

NOTE: The diaphragm must not be cleaned with methylated spirits.

- 7 Check all components for damage or deterioration.

Reassembling

- 8 Replace the spring, locating it in the body.
- 9 Locate the diaphragm in the body and on to the spring.
- 10 Replace the cover and refit the spring clip. Ensure diaphragm is seating properly and the cover fits evenly to the body.
- 11 Warm up engine and adjust carburetter if necessary.

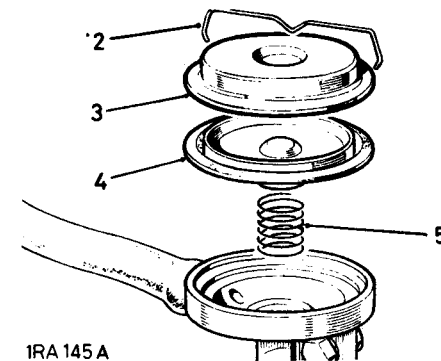

EVAPORATIVE LOSS CONTROL

Description 17.15.00

Fuel tank evaporative emissions are vented to an activated charcoal filled container where they are adsorbed, then vented through a flame trap to the combustion air intake system during engine running as follows:

- 1 A charcoal-filled adsorption container is situated in the engine compartment, to deal with evaporative emissions from the fuel tank.
- 2 From the main fuel tank there is a main tank breather pipe.
- 3 This is fed into a separate expansion tank.
- 4 From the expansion tank a further breather pipe leads to the charcoal container.
- 5 At the side of the container, an air inlet pipe is open to atmosphere.
- 6 From the top, a pipe leads to the carburettor air cleaner elbow.
- 7 Normal fuel tank breathing is through the air inlet pipe on the charcoal container and then through the two breather pipes via the expansion tank.
- 8 Any vapours from the fuel in the main or expansion tanks are fed via the main breather and expansion tank breather pipes into the charcoal container, where they are adsorbed on the charcoal and do not escape to atmosphere.
- 9 During engine accelerating conditions air is drawn in through the air inlet pipe at the side of the container, purging the trapped emissions into the engine through the carburettor air cleaner elbow.

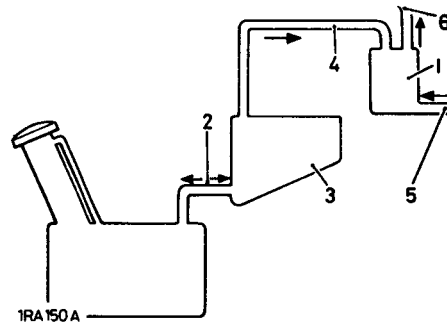

- 10 The function of the expansion tank is to provide an overflow reservoir for the main tank, as it is possible when the main tank is completely filled in high ambient temperature conditions for the fuel to expand and for a large quantity along the breather pipe. The size of the expansion tank allows for maximum fuel expansion; under such conditions evaporative emissions are still controlled by the charcoal and, due to the location of the breather pipe at the bottom of the expansion tank, the overflow fuel will eventually be drawn back into the main tank as fuel is used.

ADSORPTION CANISTER

Remove and refit 17.15.13

WARNING: No attempt should be made to cleanse the container. The use of compressed air could cause the activated charcoal filling to ignite.

- 1 Note the hose positions and disconnect at container.
- 2 Remove the fixings, container strap to mounting bracket.
- 3 Slacken the pinch bolt on the strap.
- 4 Withdraw and discard the canister.

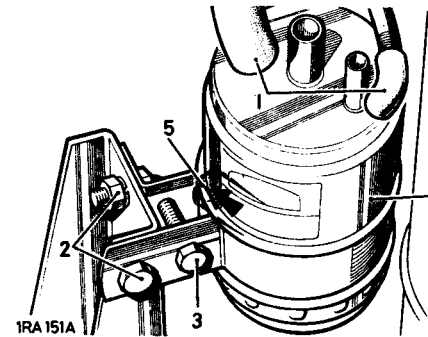

Refitting

- 5 Reverse 1 to 4. Position the container such that the 'open-to-atmosphere' pipe faces inboard and toward the rear of the engine compartment.

EXHAUST EMISSION CONTROL

Description 17.20.00

Exhaust emission control is achieved by alterations to carburation and combustion characteristics, together with modifications to the distributor vacuum supply line and ignition timing procedure, as follows:

Carburettor jets

The carburettor is provided with main and enrichment jets having special flow characteristics. The jets are identifiable by their cadmium plated finish and they are not interchangeable with similar size jets with a natural finish.

Carburettor throttle-prop system

Under high manifold depression, that is, on engine overrun with rapid throttle closure, wet fuel is drawn off the inlet manifold walls and gives a rich air/fuel ratio and poor combustion. To compensate for this condition a system is employed of propping open the carburettor throttle butterfly to reduce the manifold depression and admit sufficient volume of the correct air/fuel mixture to give good combustion.

- 1 A trigger valve is connected to the inlet manifold via a pipe.
- 2 Under high manifold depression a vacuum is formed in the trigger valve lifting a diaphragm from its seat which is pre-set to lift at 20.5 to 21.5 in. Hg.
- 3 The depression is relayed via a pipe to a vacuum servo unit.

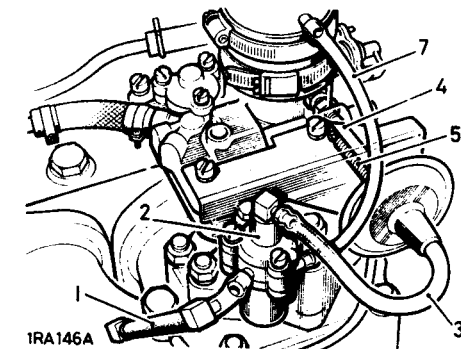

- 4 Attached to the vacuum unit is an adjusting rod.
- 5 A spring push/pull link is attached to the vacuum diaphragm.
- 6 The depression moves the vacuum unit diaphragm with subsequent movement of the spring link and throttle-prop lever which opens the throttle butterfly a small amount.
This position is maintained until the vacuum in the inlet manifold drops with the decrease in engine speed to approximately 19 in. Hg when the trigger valve diaphragm closes and movement of the vacuum unit closes the throttle butterfly.
- 7 An atmospheric bleed pipe from the air cleaner elbow to the trigger valve allows clean air at atmospheric pressure to replace the vacuum after closure of the trigger valve diaphragm.

Accelerator pump linkage setting

- 1 The accelerator pump linkage is set in the position to give maximum pump stroke by connecting the throttle relay lever to the hole in the pump spindle lever which is nearest to the pump spindle.

Solenoid operated fuel cut-off valve

The idle speed of the 2¼ litre engine has been increased to 750-800 revs/min. This has been done to increase the air-flow pass the throttle butterfly under closed throttle conditions.

- 1 To prevent running-on due to the high idle speed, a solenoid operated fuel cut-off valve has been incorporated in the carburetter.

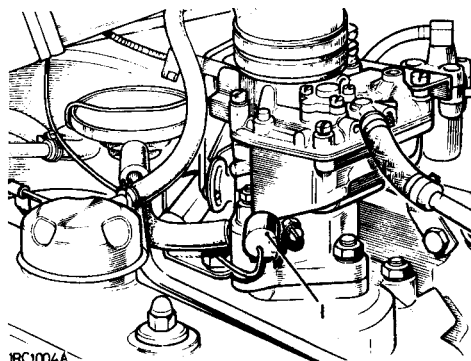

- 2 This takes the form of a solenoid operated needle valve operating to cut-off the idle by-pass drilling and progression chambers when the ignition is switched off.
- 3 The solenoid is located externally on the carburetter body casting adjacent to the idling volume control screw and is electrically connected to the switch side (+) of the ignition coil.
- 4 The fuel cut-off valve is pre-set.

Fuel filter

The filter assembly, located between the carburetter and the fuel pump at the right-hand side of the engine, provides additional filtration to the fuel system. The filter mesh is sealed inside the filter body and no servicing is possible on the assembly; the filter assembly complete must be discarded at the stipulated maintenance intervals, or before if the presence of foreign matter is suspected in the fuel system, and a new assembly fitted.

Ignition system

A special ignition distributor provides a retarded ignition setting at the lower speed range whilst maintaining the normal advance characteristics at higher engine speeds. However, when the throttle is closed at higher engine speeds a retarded ignition is required, and is achieved by fitting a throttle controlled vacuum switch. The switch is interposed in the vacuum line between the inlet manifold banjo connection and the distributor vacuum retard capsule. A throttle-operated cam governs the switch position progressively from open to closed. At the open position (switch plunger out) the switch closes off the vacuum line and opens the distributor capsule to atmosphere which allows ignition to advance. At the closed position (switch plunger in) the switch opens the vacuum line to the distributor capsule, which retards the ignition.

- 1 The switch is interposed in the vacuum line between the inlet manifold banjo connection and the distributor vacuum retard capsule.
- 2 A throttle-operated cam governs the switch position progressively from open to closed.
- 3 At the open position (switch plunger out) the switch closes off the vacuum line and opens the distributor capsule to atmosphere which allows ignition to advance.
- 4 At the closed position (switch plunger in) the switch opens the vacuum line to the distributor capsule, which retards the ignition.

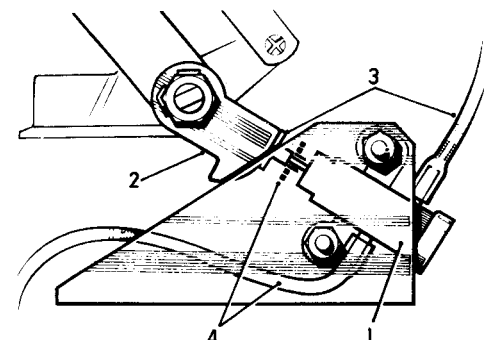

continued

Ignition timing

To ensure correct combustion, and therefore compliance with the exhaust emission regulations, it is essential that the ignition timing is dynamically set with the engine at idling speed. This requires the use of a suitable tachometer, for determining the engine speed, and a stroboscopic lamp for determining the points in the engine cycle at which the ignition sparks occur. Static ignition timing. TDC, may be used as an initial setting procedure after distributor remove and refit, but this must not be accepted as a final setting. The timing mark for the engine appears on the crankshaft pulley.

Procedure for dynamic ignition timing

- 1 Ensure that the throttle-controlled vacuum switch is correctly set and that all pipes to the switch are sound and correctly fitted.
- 2 Connect a stroboscopic timing light to the engine in accordance with the manufacturer's instructions. The HT connection should be made on No. 1 cylinder sparking plug.
- 3 Connect suitable electronic checking equipment following the manufacturer's instructions.
- 4 Set the engine idling speed to between 750 and 800 revs/min and as close to 800 revs/min as possible without exceeding this speed. This speed setting is extremely important and any deviation, particularly in an upwards direction, will cause incorrect timing and subsequent failure to pass the emission requirements.
- 5 Slacken the distributor clamping plate bolt and rotate the distributor until the stroboscopic light synchronises the timing pointer and the timing mark at 6° after top dead centre (ATDC).

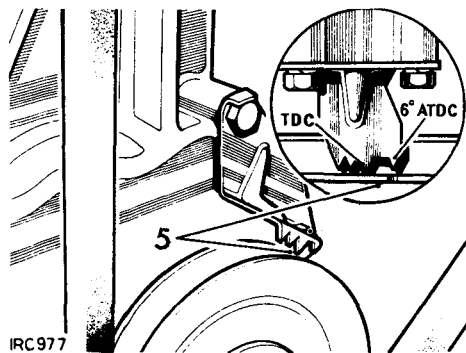

- 6 Retighten the distributor clamping bolt securely and recheck timing.

- 7 Check distributor centrifugal advance curve to the following:

Distributor speed revs/min	Distributor degrees advance
1000	9-11
1600	14-16
2000	17-19

- 8 Check distributor vacuum retard curve:

Vacuum Inches Hg	Distributor degrees retard
1	0 -0.5
2	0.5-3.0
3	2.5-3.5

- 9 Disconnect the stroboscopic timing light and electronic equipment.

THROTTLE CONTROLLED VACUUM SWITCH

Check and adjust items 4 to 7 17.20.24
Remove and refit items 1 to 3 17.20.25

Removing

- 1 Disconnect the vacuum pipes.
- 2 Remove the fixings and withdraw the switch.

Refitting

- 3 Reverse instructions 1 and 2.

To check and adjust switch position

Check/adjust the throttle-controlled vacuum switch as follows:

- 4
 - a Ensure that the throttle linkage is fully returned to the idle position.
 - b Push the plunger fully into the switch and hold it in this position.
 - c Measure the clearance between the plunger and the cam on the throttle linkage. This must be 0,05 to 0,10 mm.
 - d Adjust as necessary by slackening the fixings, mounting bracket to inlet manifold, and moving the switch and bracket complete in the required direction.

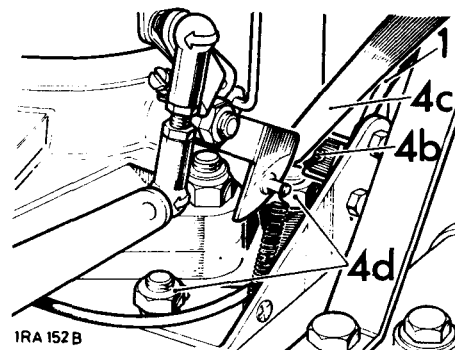

- 5 Start the engine and warm it to normal running temperature.
- 6 When the engine is idling steadily, disconnect the retard pipe at the distributor. A noticeable rise in engine speed should be apparent if the system is functioning.
- 7 When satisfied that the facility is operating correctly, reconnect the vacuum pipe to the distributor, ensuring a secure connection.

CARBURETTER THROTTLE PROP

Remove and refit

17.20.35

Removing

- 1 Remove the interconnecting link.
- 2 Remove the locknut from the diaphragm unit positioning rod.
- 3 Disconnect the spring link at the cranked lever on the throttle spindle.
- 4 Disconnect the vacuum pipe.
- 5 Withdraw the diaphragm unit from the bracket.
- 6 Remove the trigger valve unit and bracket complete from the carburetter.

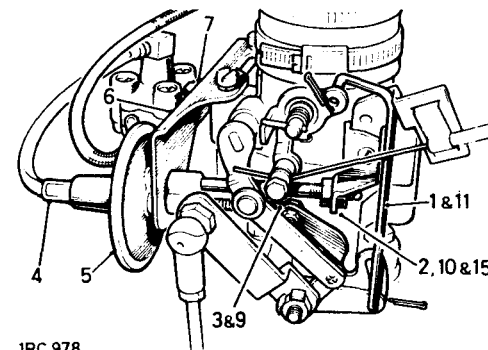

IRC 978

Refitting

- 7 Reverse instruction 6, positioning the spacer for the front fixing.
- 8 Reverse 4 and 5.
- 9 Reverse 3 with the spring link eye and the shoulder-bolt head positioned at the carburetter side of the throttle prop lever.
- 10 Reverse 2. Do not tighten the locknut at this stage and ensure that the throttle prop lever is clear of the slow run stop lever.
- 11 Fit the interconnecting link.
- 12 Set the carburetter throttle-prop as follows, instructions 13 to 20.

Setting the carburetter throttle-prop lever

- 13 Run the Land Rover for a minimum of 4 km (3 miles) to ensure that the engine is at normal running temperature.

- 14 Connect an accurate stroboscopic tachometer to the engine and ensure that it is idling at 750 to 800 revs/min.
- 15 Slacken the locknuts securing the vacuum unit adjusting rod at the carburetter bracket.
- 16 Operate the accelerator linkage to increase the engine speed to approximately 2,500 revs/min.
- 17 At the same time disconnect the atmospheric bleed pipe from the air cleaner elbow and block off the end of the pipe by the thumb or finger. This retains the vacuum supply from the trigger valve and ensures that the throttle butterfly remains propped.
- 18 Release the accelerator linkage, engine speed will fall to accelerator propped position. Rotate the adjusting rod locknuts by equal amounts to increase or decrease the engine speed as necessary until 1300 to 1400 revs/min is obtained.
- 19 Tighten the locknuts against the bracket and replace the vacuum balance pipe on to the air cleaner elbow. Ensure that the engine returns to its normal idling speed.
- 20 Switch off the engine and remove the tachometer.
- 21 The trigger valve is pre-set and must not be adjusted.

FUEL FILTER

Remove and refit 17.20.38

Removing

- 1 Disconnect fuel pipes from each end of filter.
- 2 Slacken clip securing filter and withdraw unit.

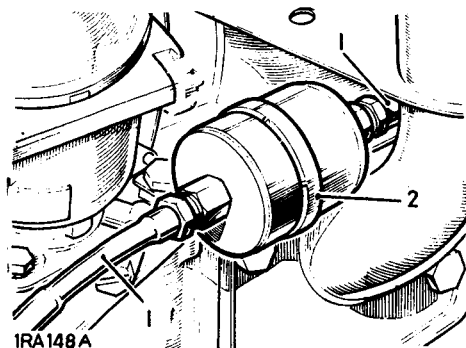

Refitting

- 3 Fit the new filter with the end marked 'IN' towards the fuel pump, using the nuts and olives supplied. If the filter is marked with an arrow, this indicates fuel flow direction and the filter must then be fitted with the arrow pointing away from the fuel pump.

AIR INJECTION SYSTEM

Description 17.25.00

The air pump driven by the engine, delivers air to the exhaust valves via the air rail/manifold (3). A check valve (2) prevents damage to the pump should back-fire or belt breakage occur. A relief valve, located in the air pump (1) is required to dump part of the air at high speed to prevent pump damage.

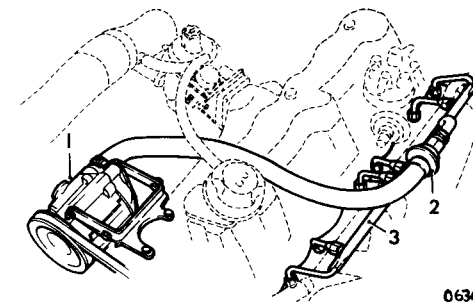

AIR PUMP

Remove and refit 17.25.07

Removing

- 1 Slacken the adjustment bolts and remove the drive belt from the air pump pulley.
- 2 Remove the two bolts securing the pump on its mounting brackets.
- 3 Lift out the air pump from the brackets.

Refitting

- 4 Reverse 2-3 above.
- 5 Refit the drive belt and adjust.
- 6 Tighten the three adjustment bolts

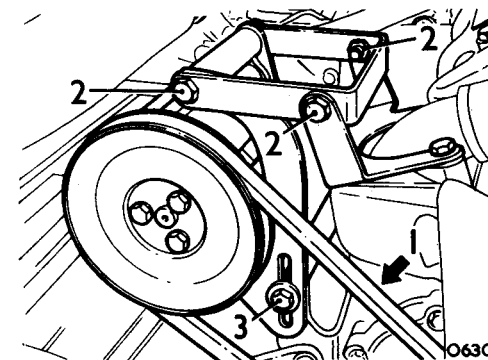

AIR PUMP DRIVE BELT

Tensioning 17.25.13

The correct tension for the air pump drive belt is 6.3 mm (0.25 in.) total lateral movement at the mid point of its run between the air pump and water pump pulleys:

AIR PUMP DRIVE BELT

Remove and refit 17.25.15

- 1 Refer to 17.25.07 for illustration.
- 2 Slacken the four securing bolts.
- 3 Push the air pump downwards and remove the belt.

Refitting

- 4 Fit new belt and tension to the figure given in 17.25.13.
- 5 Ensure all securing bolts are light.

AIR RAIL/MANIFOLD**Remove and refit** 17.25.19

- 1 Remove the exhaust manifold 30.15.10.
- 2 Remove the heater rail (if fitted).
- 3 Disconnect the air hose from the injection rail.
- 4 Remove the side rocker cover.
- 5 Lift off the injection rail/manifold assembly.
- 6 Where required remove the six union nuts securing the injection rail to the manifold.

Refitting

- 7 Reverse 1-6 above.

CHECK VALVE**Remove and refit** 17.25.21**Removing**

- 1 Disconnect the air hose from the diverter and relief valve to the check valve.
- 2 Using two open-ended spanners - one on the air distribution manifold hexagon, to support the manifold, and the other to remove the check valve anti-clockwise.

CAUTION: Do not impose any strain on the air manifold.

Refitting

- 3 Reverse instructions 1 and 2.

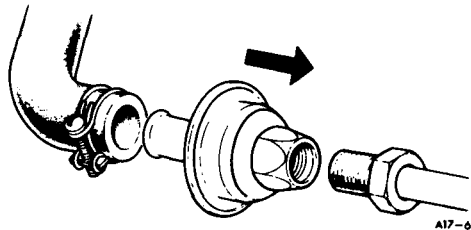
**CHECK VALVE****Test** 17.25.22**Testing**

CAUTION: Do not use a pressure air supply for this test.

- 1 Remove the check valve. 17.25.21.
- 2 Blow through the valve orally in both directions in turn. Air should only pass through the valve when blown from the hose connection end in direction of arrow. Should air pass through the valve when blown from the air manifold end, renew the valve.
- 3 Refit the check valve. 17.25.21.

ANTI-RUN-ON VALVE**Remove and refit** 17.40.01

- 1 Disconnect the electrical leads.
- 2 Remove the two screws securing the valve to the bracket.
- 3 Remove the valve.

Refitting

- 4 Reverse instructions 1 to 3 above.
- 5 If the valve adjustment is correct the engine idle speed should be 500-600 r.p.m.

NOTE: If the mounting bracket has to be renewed, the carburetter must be removed 19.15.09.

Check 17.40.14

With the engine running at idle (500-600 r.p.m.) disconnect the electrical lead at the valve and note that the engine stalls. If this does not happen the idle speed is incorrect. Reconnect the electrical connection and reset the idle speed using the correct method of adjustment at the base of the anti-run-on valve only.

EXHAUST GAS RECIRCULATION (E.G.R.) - 2½ litre Australia 17.45.00

To reduce the oxides of nitrogen content in the exhaust, the peak combustion temperatures are lowered by recirculating a controlled quantity of the exhaust gases through the combustion process.

The E.G.R. valve is mounted on an expansion chamber. A control signal, taken from a throttle edge tapping in the carburetter, gives no recirculation at idle or full load, but does allow an amount of recirculation, dependent on the vacuum signal and a metering profile on the valve, under part load conditions.

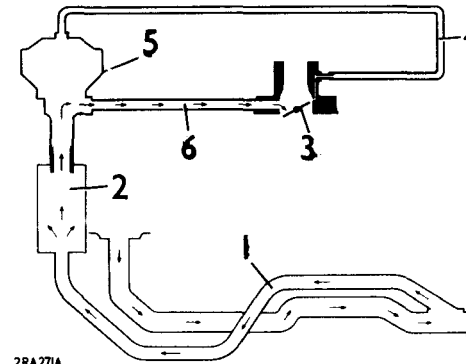

- 1 Exhaust feed back
- 2 Expansion chamber
- 3 Carburetter butterfly
- 4 E.G.R. control line
- 5 E.G.R. valve
- 6 E.G.R. feed line

E.G.R. VALVE**Remove and refit** 17.45.01**Removing**

- 1 Disconnect the vacuum control pipe from the top of the E.G.R. valve.
- 2 Disconnect the union at the base of the E.G.R. valve assembly.
- 3 Release the pipe from the trigger valve to allow clearance when removing the E.G.R. valve assembly.
- 4 Remove the nut and washer securing the bracket to the top of the manifold.
- 5 Remove the bolt securing the bracket to the side of the manifold.
- 6 Lift and withdraw the E.G.R. valve assembly from the carburetter.

Refitting

- 7 Change all relevant brackets and reverse instructions 1 to 6.

E.G.R. VALVE**Overhaul** 17.45.02

- 1 Remove the valve. 17.45.01.
- 2 Clean the assembly area of the valve with a wire brush. Use a standard spark plug machine to clean the valve and seat. Ensure that the E.G.R. valve outlet is securely plugged to prevent injury from the sand blast. Insert the valve opening into the machine and lift the diaphragm evenly.
- 3 Blast the valve for approximately 30 seconds then remove and inspect it. If necessary repeat until all carbon deposits are removed. Unplug the valve outlet and use compressed air to remove all traces of carbon grit from the valve.
- 4 Refit the E.G.R. valve.

E.G.R. SYSTEM

Check 17.45.20

- 1 Check function of E.G.R. valve as follows:
Warm the engine to normal running temperature and ensure that the choke control is fully off.
Open and close the throttle several times and observe or feel the E.G.R. valve, which should open and close with the changes in engine speed.
The valve should close instantly when the throttle is closed.
- 2 If the operation of the valve does not appear completely satisfactory, make a full check on the operation of the valve by connecting the vacuum pipe of a distributor vacuum test unit to the valve.
Ensure that the valve is actuated, held fully open at an applied vacuum of 10 in. Hg. and that there is no leak of vacuum.
- 3 If valve is unsatisfactory fit a new valve.

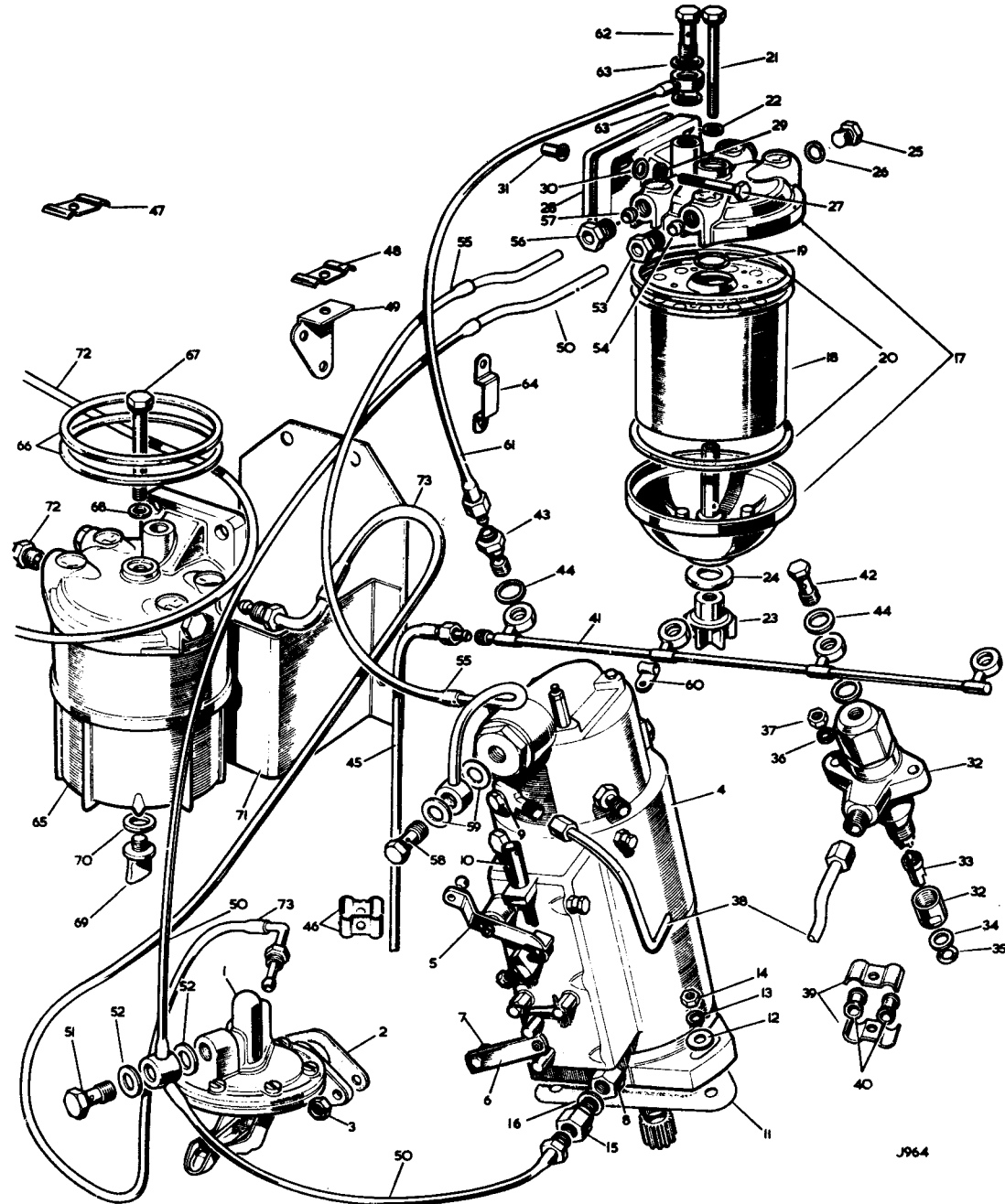

J964

KEY TO GENERAL LAYOUT OF DIESEL INJECTION SYSTEM

- | | |
|--|--|
| <p>1 Fuel pump, mechanical
 2 Joint washer, fuel pump to cylinder block
 3 Self-locking nut, fixing fuel pump
 4 Distributor pump
 5 Accelerator control lever
 6 Stop lever
 7 Swivel clamp for stop lever
 8 Union, fuel pipe connection
 9 Joint washer for injection pipe, distributor pump end
 10 Sleeve for control lever stop screw
 11 Joint washer for distributor pump
 12 Plain washer
 13 Spring washer
 14 Nut $\frac{5}{16}$ in. UNF)
 15 Non-return valve for distributor pump
 16 Joint washer for non-return valve
 17 Fuel filter
 18 Element for fuel filter
 19 Seal for element, small
 20 Seal for element, large
 21 Special centre bolt for filter
 22 Washer for centre bolt
 23 Nylon drain plug for filter
 24 Rubber seal for drain plug
 25 Plug for filter
 26 Joint washer for plug
 27 Bolt ($\frac{5}{16}$ in. UNF \times $1\frac{1}{8}$ in. long)
 28 Distance plate
 29 Spring washer
 30 Plain washer
 31 Rivnut ($\frac{5}{16}$ in. UNF)
 32 Injector complete
 33 Nozzle for injector
 34 Joint washer for injector, copper
 35 Joint washer for injector, steel
 36 Spring washer
 37 Nut ($\frac{5}{16}$ in. UNF)
 38 Injector pipe to No. 2 cylinder</p> | <p>39 Clamping plate for injector pipe grommet
 40 Grommet for injector pipe
 41 Spill rail pipe complete
 42 Banjo bolt for No. 1, 2 and 3 injectors
 43 Banjo union for No. 4 injector
 44 Joint washer for banjo bolt
 45 Fuel pipe, spill return to tank
 46 Double clip, clamping feed and return pipes together
 47 Double clip, fixing feed and return pipes to chassis sidemember
 48 Double clip for feed and return pipes
 49 Bracket for clip
 50 Fuel pipe, mechanical pump and distributor pump to filter
 51 Banjo bolt
 52 Joint washer
 53 Nut
 54 Olive
 55 Fuel pipe, filter to distributor pump
 56 Nut
 57 Olive
 58 Banjo bolt
 59 Joint washer
 60 Clip, fixing fuel pipe to distributor pump
 61 Fuel pipe filter to spill rail at No. 4 injector
 62 Banjo bolt
 63 Joint washer
 64 Double clip, fixing fuel pipes to bulkhead
 65 Sedimentor
 66 Seal for sedimentor
 67 Special centre bolt for sedimentor
 68 Washer for centre bolt
 69 Drain plug for sedimentor
 70 Rubber seal for drain plug
 71 Mounting bracket for sedimentor
 72 Fuel pipe, tank to sedimentor
 73 Fuel pipe, sedimentor to mechanical pump</p> |
|--|--|

DIESEL FUEL SYSTEM

General notes

- 1 Observe strict cleanliness precautions when servicing Diesel fuel system components.
- 2 If the distributor/injection pump is drained of fuel it must be fully primed before attempting to start the engine.

Fuel filtration

- 3 A minimum of three filters are fitted as follows:
 - a Fuel tank filter.
 - b Sedimentor bowl filter mounted on the R.H. chassis side member. This filter is fitted to all Export models and is optional on U.K. market models.
 - c Element type filter mounted on the engine bulkhead.
 - d Tubular gauze filter in the distributor/injection pump inlet connection.

Distributor pump

- 4 No attempt should be made to overhaul the distributor pump, as this requires specialised knowledge and equipment outside the scope of this Manual. If a distributor pump gives trouble, a new replacement should be fitted.

Fuel injectors

- 5 Injectors have a 'Pintaux' type nozzle which has been developed by CAV for use with the design of cylinder head used on Rover compression ignition engines. This type of nozzle has been found most satisfactory for starting and general running and must be replaced by the same type only.

Fuel lift pump

- 6 The fuel lift pump is secured directly to the right hand side of the engine, and is mechanically operated from the engine camshaft. The pump is similar to that used on 2¼ litre Petrol models.

Fuel system arrangement

Low pressure system

- 7 Fuel is drawn from the fuel tank into the sedimentor, where fitted.
- 8 From the sedimentor, or tank, to the fuel lift pump.
- 9 From the lift pump to the main fuel filter.
- 10 From the filter to the distributor/injection pump.

High Pressure system

- 11 Fuel passes from the distributor/injection pump to the fuel injectors.

Spill return system

- 12 Excess fuel spills back from the injectors and main filter to the tank.
- 13 Excess fuel spills back from the distributor/injection pump to the fuel lift pump outlet line.

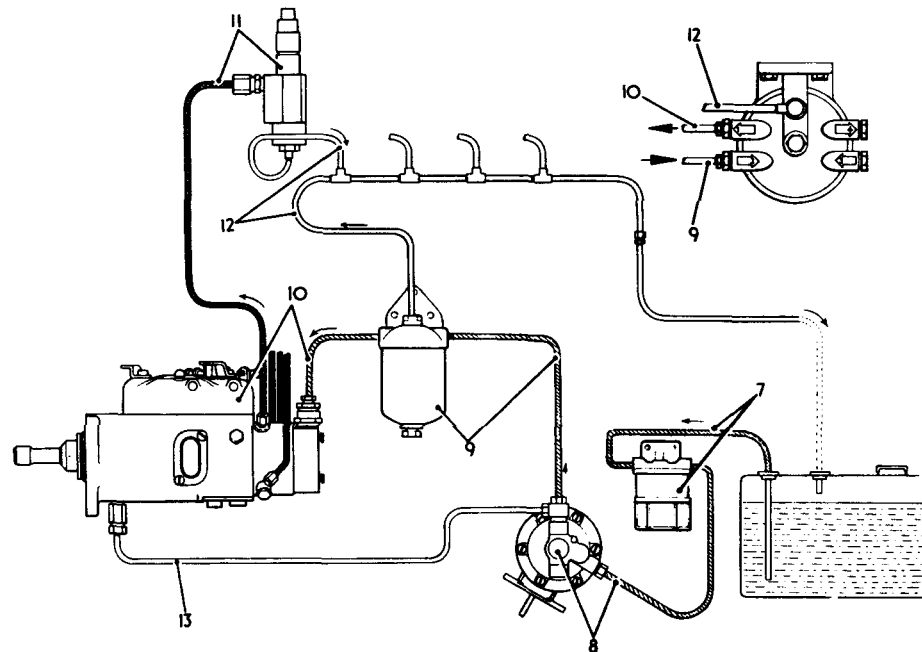

2RC 170

KEY TO ILLUSTRATION OF ACCELERATOR CONTROLS, 2¼ LITRE DIESEL MODELS

- 1 Housing for accelerator shaft and pedal stop
- 2 Bolt (¼ in. UNF X ½ in. long) Fixing housing
- 3 Spring washer and pedal stop
- 4 Nut (¼ in. UNF) to dash
- 5 Bracket for accelerator pedal shaft
- 6 Bolt (¼ in. UNF X $\frac{5}{8}$ in. long)
- 7 Plain washer Fixing bracket
- 8 Spring washer to dash
- 9 Nut (¼ in. UNF)
- 10 Shaft for accelerator pedal
- 11 Accelerator pedal
- 12 Bolt ($\frac{5}{16}$ in. UNF X $\frac{7}{8}$ in. long) Fixing pedal
- 13 Nut ($\frac{5}{16}$ in. UNF) to shaft
- 14 Bolt ($\frac{5}{16}$ in. UNF X 2½ in. long) Pedal
- 15 Plain washer stop in
- 16 Nut ($\frac{5}{16}$ in. UNF) floor
- 17 Lever for accelerator on pedal shaft
- 18 Bolt (¼ in. UNF X 1½ in. long) Fixing lever
- 19 Nut (¼ in. UNF) to shaft
- 20 Return spring for pedal
- 21 Anchor for return spring
- 22 Bracket for accelerator cross-shaft
- 23 Bolt (¼ in. UNF X $\frac{5}{8}$ in. long) Fixing
- 24 Spring washer brackets
- 25 Nut (¼ in. UNF) to dash
- 26 Accelerator cross-shaft
- 27 Stop clip for cross-shaft
- 28 Accelerator lever on cross-shaft from pedal
- 29 Distance washer for cross-shaft
- 30 Bolt (¼ in. UNF X 1½ in. long) Fixing levers and
- 31 Nut (¼ in. UNF) stop clip to cross-shaft
- 32 Control rod, pedal shaft to cross-shaft
- 33 Ball joint socket For
- 34 Locknut (2 BA) rod
- 35 Control rod, pedal shaft to cross shaft
- 36 Linkage clip for control rod
- 37 Control rod, bell crank to accelerator lever
- 38 Ball socket
- 39 Nut (2 BA) For bell crank control rod
- 40 Adjuster nut
- 41 Return spring for accelerator and stop levers on distributor pump
- 42 Anchor for return spring
- 43 Accelerator lever on cross-shaft to engine
- 44 Control rod, cross-shaft to bell crank
- 45 Ball joint For
- 46 Locknut (2 BA) control rod
- 47 Control rod, cross-shaft to bell crank
- 48 Linkage clip for control rod
- 49 Bracket for bell crank on distributor pump
- 50 Spring washer Fixing bracket to
- 51 Nut (10 UNF) distributor pump

- 52 Bell crank complete on distributor pump
- 53 Bush for bell crank
- 54 Ball end for bell crank
- 55 Pin for bell crank
- 56 Shakeproof washer Fixing pin to bell
- 57 Nut (¼ in. UNF) crank bracket
- 58 Plain washer Fixing bell crank
- 59 Split pin lever to pin
- 60 'Engine stop' control
- 61 Clip Fixing control outer cable
- 62 Screw (2 BA X $\frac{5}{8}$ in. long) to abutment bracket on distributor pump

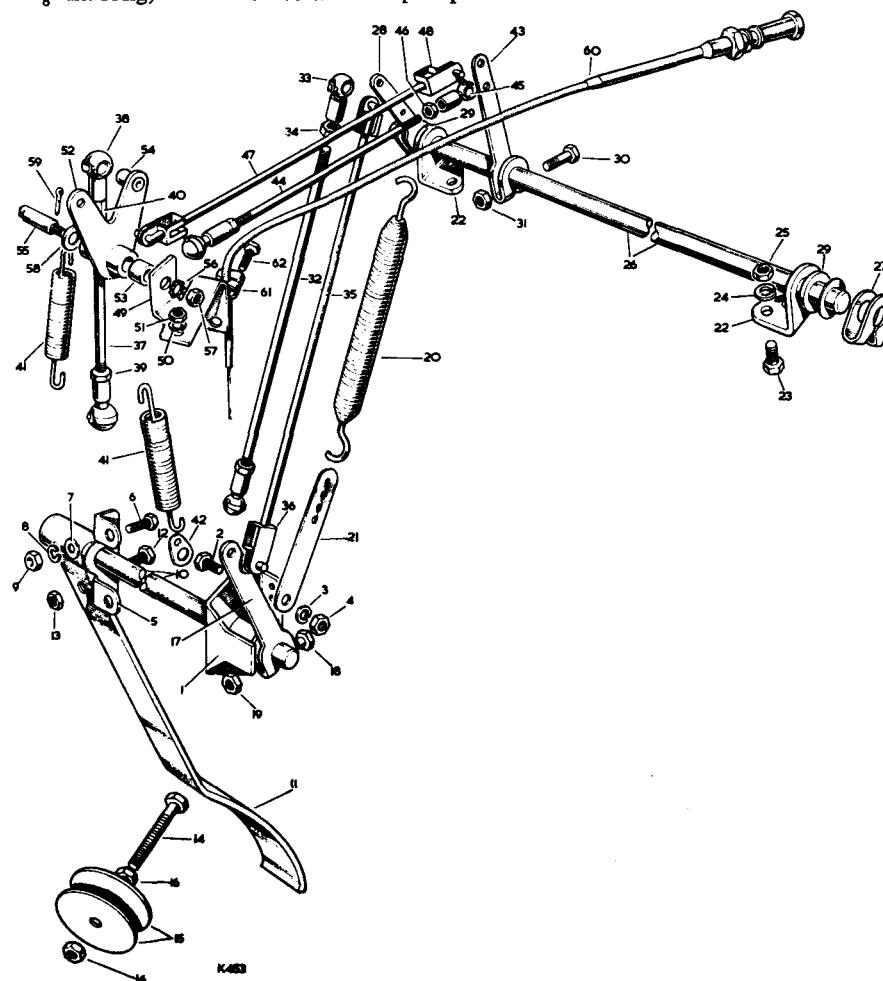

KEY TO ILLUSTRATION OF ACCELERATOR CONTROLS, 2¼ LITRE PETROL MODELS

- | | | |
|----|---|---|
| 1 | Housing for accelerator shaft and pedal stop | |
| 2 | Bolt (¼ in. UNF X ½ in. long) | Fixing housing and pedal stop |
| 3 | Spring washer | |
| 4 | Nut (¼ in. UNF) | to dash |
| 5 | Bracket for accelerator pedal shaft | |
| 6 | Bolt (¼ in. UNF X ⅝ in. long) | |
| 7 | Plain washer | Fixing bracket to dash |
| 8 | Spring washer | |
| 9 | Nut (¼ in. UNF) | |
| 10 | Shaft for accelerator pedal | |
| 11 | Special washer | On accelerator shaft |
| 12 | Plain washer | |
| 13 | Accelerator pedal | |
| 14 | Bolt (⅝ in. UNF X ⅞ in. long) | Fixing pedal to shaft |
| 15 | Nut (⅝ in. UNF) | |
| 16 | Bolt (⅝ in. UNF X 1⅛ in. long) | Pedal stop in floor |
| 17 | Plain washer | |
| 18 | Nut (⅝ in. UNF) | |
| 19 | Bracket for accelerator cross-shaft, 'L' shaped | |
| 20 | Bolt (¼ in. UNF X ⅝ in. long) | Fixing bracket to dash |
| 21 | Spring washer | |
| 22 | Nut (¼ in. UNF) | |
| 23 | Cross-shaft for accelerator | |
| 24 | Distance washer for lever | |
| 25 | Lever for accelerator | |
| 26 | Bolt (¼ in. UNF X 1¼ in. long) | Fixing levers to shaft |
| 27 | Plain washer | |
| 28 | Nut (¼ in. UNF) | |
| 29 | Lever for cross-shaft | |
| 30 | Bolt (¼ in. UNF X 1¼ in. long) | Fixing lever to cross-shaft |
| 31 | Plain washer | |
| 32 | Nut (¼ in. UNF) | |
| 33 | Control rod, pedal shaft to cross-shaft | |
| 34 | Control rod, pedal shaft to cross-shaft | |
| 35 | Linkage clip for control rod | |
| 36 | Control rod, cross-shaft to engine | |
| 37 | Control rod, cross-shaft to engine | |
| 38 | Ball joint socket for rods | |
| 39 | Locknut for socket | |
| 40 | Linkage clip for control rod, cross-shaft to engine | |
| 41 | Return spring for pedal | |
| 42 | Spindle for carburetter bell crank | |
| 43 | Plain washer | |
| 44 | Spring washer | Fixing spindle |
| 45 | Nut (⅜ in. NUF) | |
| 46 | Space for spindle | |
| 47 | Torsion spring for bell crank | |
| 48 | Special washer for torsion spring | |
| 49 | Bracket for accelerator controls | |
| 50 | Bolt (⅜ in. UNF X 1 in. long) | Fixing bracket to steering column support bracket |
| 51 | Plain washer | |
| 52 | Self-locking nut (⅜ in. UNF) | |

- | | | |
|----|--|--------------------------------------|
| 53 | Carburetter bell crank lever assembly | |
| 54 | Ball end for lever | |
| 55 | Bush for bell crank | |
| 56 | Carburetter relay lever | |
| 57 | Split pin fixing levers to spindle | |
| 58 | Control rod, bell crank to carburetter | |
| 59 | Ball joint For control rod | |
| 60 | Locknut (2 BA) | |
| 61 | Ball end for carburetter lever | |
| 62 | Spring washer | Fixing ball end to carburetter lever |
| 63 | Nut (¼ in. UNF) | |

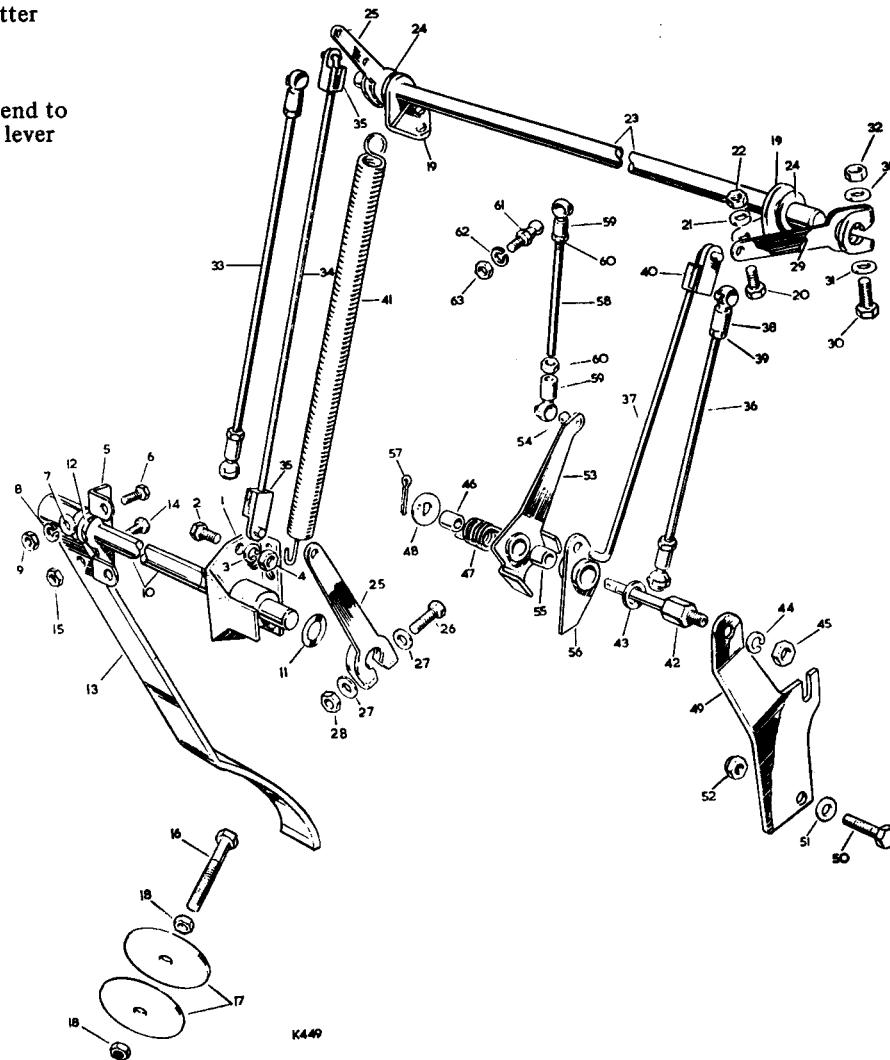

KEY TO ILLUSTRATION OF ACCELERATOR LEVERS AND RODS, 2.6 LITRE, 6 CYLINDER MODELS

- | | | | |
|----|--|----------------------|--|
| 1 | Bracket for accelerator pedal and stop | | |
| 2 | Bolt (¼ in. UNF X ½ in. long) | Fixing bracket | |
| 3 | Spring washer | and pedal stop | |
| 4 | Nut (¼ in. UNF) | to dash | |
| 5 | Pedal stop lever | | |
| 6 | Bolt (¼ in. UNF X 1¼ in. long) | Fixing lever | |
| 7 | Plain washer | to | |
| 8 | Nut (¼ in. UNF) | pedal shaft | |
| 9 | Accelerator pedal | | |
| 10 | Pad for accelerator pedal | | |
| 11 | Bolt (⅝ in. UNF X ⅞ in. long) | Fixing pedal | |
| 12 | Nut (⅝ in. UNF) | to shaft | |
| 13 | Bolt (⅝ in. UNF X 1⅛ in. long) | Pedal | |
| 14 | Plain washer | stop in | |
| 15 | Nut (⅝ in. UNF) | floor | |
| 16 | Bracket for accelerator pedal shaft | | |
| 17 | Bolt (¼ in. UNF X ⅝ in. long) | | |
| 18 | Plain washer | Fixing bracket | |
| 19 | Spring washer | to dash | |
| 20 | Nut (¼ in. UNF) | | |
| 21 | Shaft for accelerator pedal | | |
| 22 | Special washer | On accelerator | |
| 23 | Plain washer | shaft | |
| 24 | Lever assembly for accelerator | | |
| 25 | Ball end for lever | | |
| 26 | Bolt (¼ in. UNF X 1¼ in. long) | | |
| 27 | Plain washer | Fixing lever | |
| 28 | Nut (¼ in. UNF) | to shaft | |
| 29 | Mounting bracket for extension shaft | | |
| 30 | Bearing in mounting bracket for shaft | | |
| 31 | Bolt (¼ in. UNF X ⅝ in. long) | Fixing | |
| 32 | Spring washer | mounting bracket | |
| 33 | Nut (¼ in. UNF) | to dash | |
| 34 | Extension shaft and lever | | |
| 35 | Ball end for extension shaft lever | | |
| 36 | Spring washer | Fixing ball end | |
| 37 | Nut (2 BA) | to lever | |
| 38 | Plain washer | For extension | |
| 39 | Conical spring for extension shaft | shaft | |
| 40 | Control rod, pedal shaft to extension shaft | | |
| 41 | Ball joint socket for control rod | | |
| 42 | Locknut (2 BA) fixing socket to control rod | | |
| 43 | Return spring, bell crank to extension shaft | | |
| 44 | Bracket assembly for accelerator cross-shaft | | |
| 45 | Bearing for cross-shaft | | |
| 46 | Accelerator cross-shaft and lever | | |
| 47 | Spiral pin for cross-shaft | | |
| 48 | Boss for cross-shaft | | |
| 49 | Spring dowel fixing boss to shaft | | |
| 50 | Bell crank lever and bearings assembly | | |
| 51 | Bearing for bell crank | | |
| 52 | Support bracket for bell crank | | |
| 53 | Set bolt (¼ in. UNC X ⅝ in. long) | Fixing support | |
| 54 | Spring washer | bracket to | |
| 55 | Centre pin | cylinder head | |
| 56 | Spring washer | Fixing bell crank to | |
| 57 | Nut (⅝ in. UNC) | support bracket | |
| 58 | Control rod, cross-shaft to bell crank | | |
| 59 | Spring washer | Fixing control rod | |
| 60 | Nut (10 UNF) | to levers | |
| 61 | Control rod, bell crank to carburetter | | |
| 62 | Ball joint | For | |
| 63 | Locknut (2 BA) | control rod | |
| 64 | Ball end | Fixing control rod | |
| 65 | Spring washer | to bell crank lever | |
| 66 | Nut (2 BA) | and carburetter | |

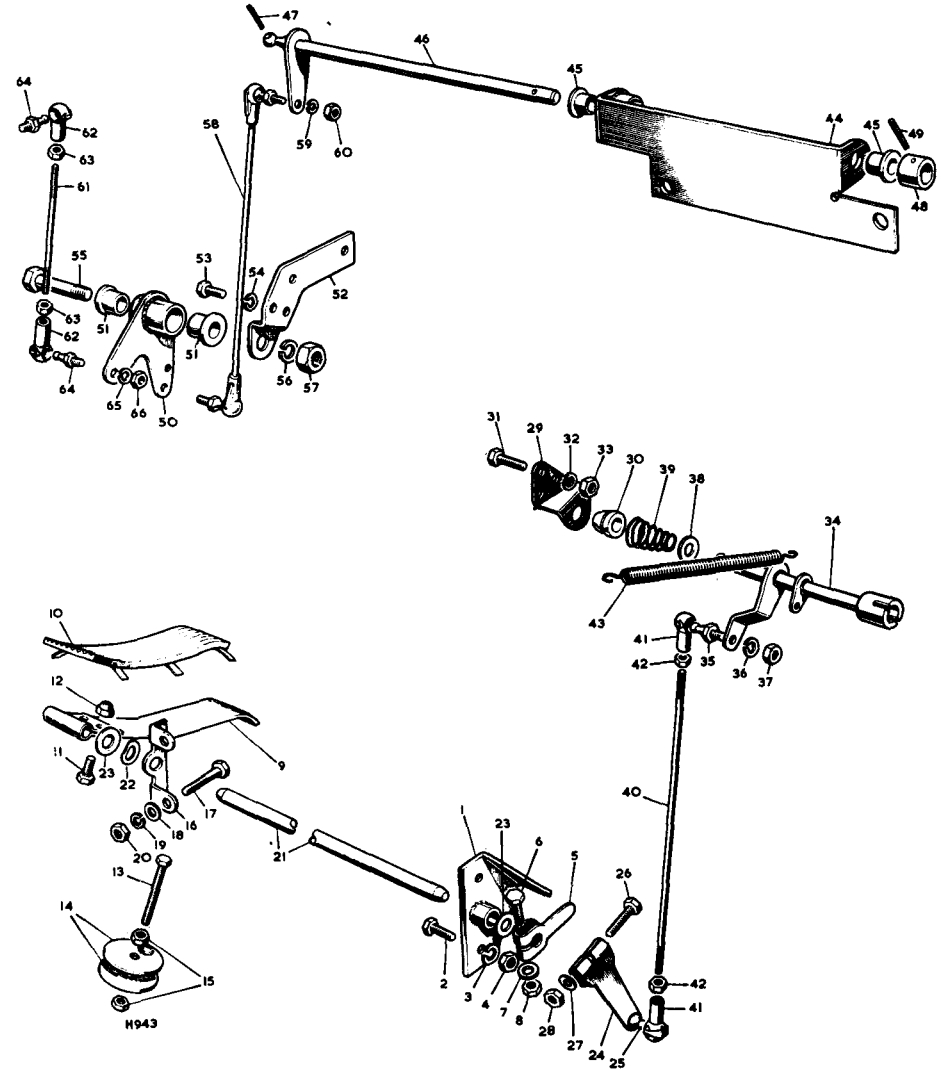

AIR CLEANER, 2½ litre models

Remove and refit 19.10.04

Removing

- 1 Lift and prop the bonnet.

Petrol models, item 2

- 2 Disconnect the air intake elbow from the carburetter.

Diesel models, items 3 and 4

- 3 Disconnect the air inlet hose from the inlet manifold.
- 4 Free the hose from the engine clip.

Petrol and Diesel models, items 5 and 6

- 5 Slacken the fixings and move aside the retaining strap.
- 6 Remove air cleaner complete with hose.

Refitting

- 7 Reverse instructions 1 to 6 as applicable. Ensure that the oil container hinged clips are clear of the retaining strap supports when fitted.

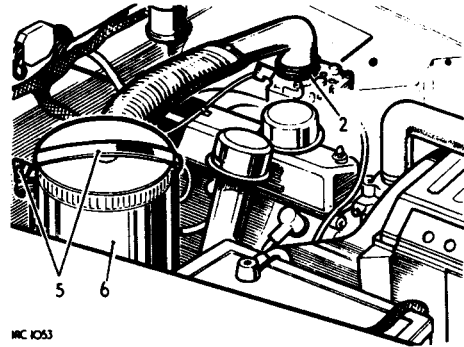

MC 1053

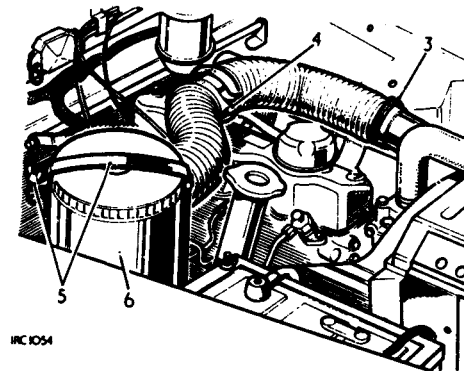

MC 1054

AIR CLEANER, 2.6 litre models

Remove and refit 19.10.04

Removing

- 1 Lift and prop the bonnet.
- 2 Disconnect the air intake hose from the carburetter inlet.
- 3 Slacken the fixings and move aside the retaining strap.
- 4 Remove the air cleaner complete with hose.

Refitting

- 5 Reverse instructions 1 to 4. Ensure that the oil container hinged clips are clear of the retaining strap supports when fitted.

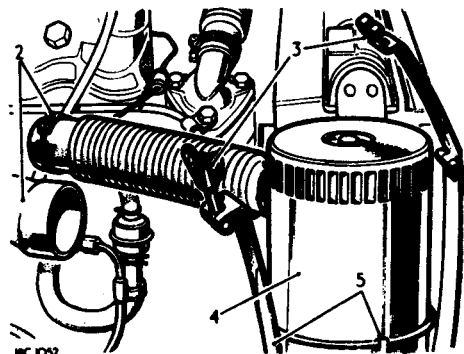

MC 1052

AIR CLEANER

Clean and refill 19.10.16

Dismantling

- 1 Remove the air cleaner. 19.10.04.
- 2 Release the hinged clips.
- 3 Withdraw the oil container.
- 4 Withdraw the sealing washer.
- 5 Lift out the wire mesh element.
- 6 Drain the oil container.
- 7 Remove the air intake cap.
- 8 Wash the metal parts in clean fuel.

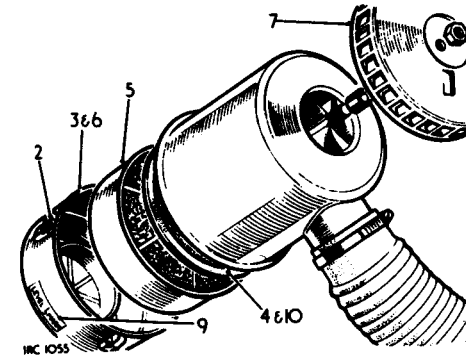

MC 1055

Assembling

- 9 Add clean engine oil to the oil container (Division 09 refers), fill to the oil level mark.
- 10 Reverse instructions 1 to 5 and 7, using a new sealing washer.

CARBURETTERS

Description 19.15.00

Variations in carburetters may be fitted to meet local territory legislation.

Tamperproofing

These carburetters may be externally identified by a tamperproof sealing tube fitted around the slow running adjustment screw. The purpose of these carburetters is to more stringently control the air/fuel mixture entering the engine combustion chambers and in consequence the exhaust gas emissions leaving the engine. For this reason the only readily accessible external adjustment on these carburetters is to the throttle settings for fast idle speed and, on some later carburetters, this may require the use of a special tool to adjust the settings.

Emission Specifications

All carburetters fitted to the Land Rover conform at the time of manufacture to particular territory requirements in respect of exhaust and evaporative emissions control.

CAUTION: Unauthorised breaking of tamperproofing devices, adjustment of carburetter settings or the fitting of incorrectly related parts may render the vehicle user liable to legal penalties according to local territory legislation. Whenever adjustments are made to the settings of tamperproofed or emission specification carburetters an approved type CO meter must be used to ensure that the final exhaust gas analysis meets with local territory legislation

CARBURETTER, Zenith type 36IV

NOTE: Where the vehicle is fitted with emission control, refer to Section 17 for variations from the basic carburetter.

Remove and refit 19.15.09

Removing

- 1 Prop open the bonnet.
- 2 Disconnect the battery earth lead.
- 3 Disconnect the fuel inlet pipe.
- 4 Disconnect the air inlet hose.
- 5 Release the cold start outer cable.
- 6 Disconnect the cold start inner cable.
- 7 Disconnect the vacuum pipe.
- 8 Disconnect the throttle linkage.
- 9 Remove the carburetter.
- 10 Lift off the adaptor piece and joint washers.

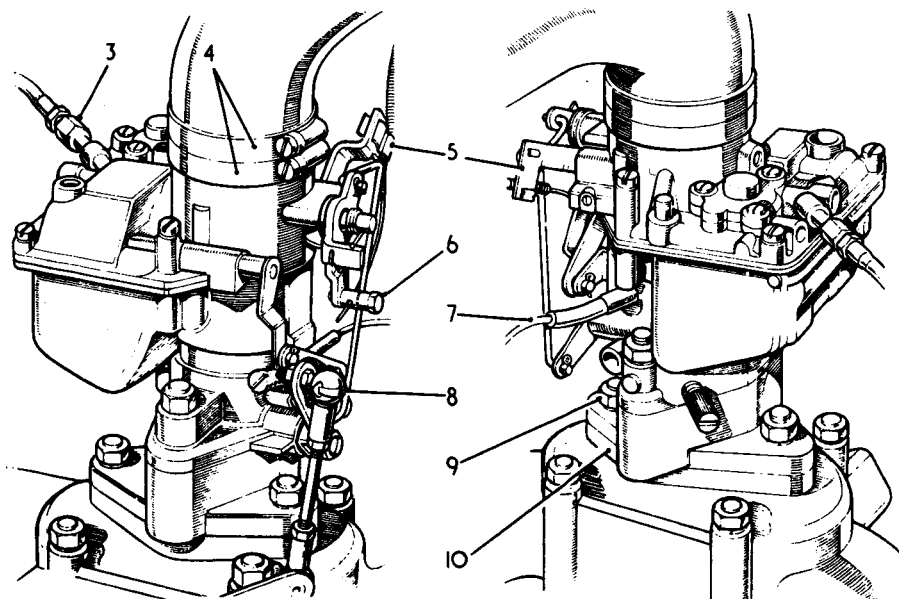

IRC 186

Refitting

- 11 Reverse instructions 2 to 10. When the cold start cable is connected, check that the maximum travel on the carburetter linkage is obtainable in both directions.
- 12 Close the bonnet.

CARBURETTER, Zenith type 175 CD2S

Remove and refit 19.15.09

Removing

- 1 Disconnect the top cover breather hose at the carburetter elbow.
- 2 Release the air cleaner retainer strap.
- 3 Withdraw the air cleaner complete with hose, carburetter elbow and joint washer.
- 4 Disconnect the distributor vacuum pipe(s).
- 5 Release the cold start control inner cable.
- 6 Withdraw the cold start outer cable from the spring clip.
- 7 Disconnect the crankcase breather hose.
- 8 Disconnect the fuel inlet pipe.
- 9 Disconnect the accelerator linkage.
- 10 Remove the fixings and withdraw the carburetter.
- 11 Withdraw the carburetter adaptor and joint washer.

Refitting

- 12 Reverse instructions 1 to 10. When the cold start cable is connected, ensure that full travel on the carburetter linkage is obtainable in both directions.

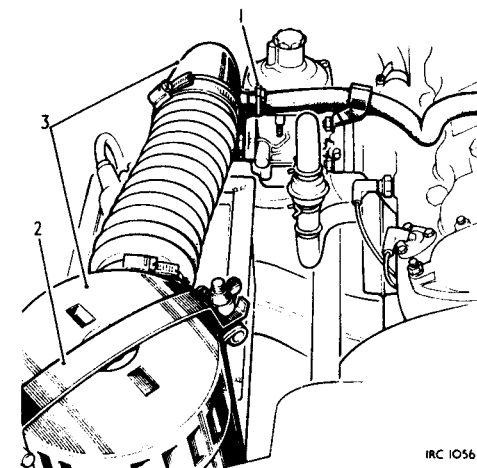

IRC 1056

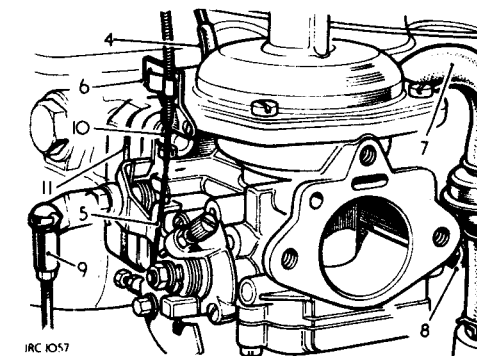

IRC 1057

CARBURETTER, Zenith type 36IV

NOTE: Refer to Section 17 for variations from the basic carburetter in respect of emission control requirements.

Overhaul and adjust 19.15.17

Dismantling

1 Remove the carburetter. 19.15.09

Linkages, removing

2 Disconnect the interconnecting link.
3 Disconnect the accelerator pump spindle lever from throttle relay lever.

Top cover and emulsion block, separating

4 Remove the top cover from the carburetter body.
5 Withdraw the float assembly.
6 Remove the needle valve housing and needle.
7 Remove emulsion block from carburetter top cover, taking care not to drop the accelerator pump assembly which is now freed.
8 Withdraw the gasket from top cover.

Emulsion block, dismantling

9 Lift out the accelerator pump piston.
10 Remove all jets in the emulsion block.
NOTE: At the base of the accelerator pump housing bore is a ball inlet valve retained by a circlip, there is no need to remove the valve for overhaul purposes.

Carburetter body, dismantling

11 Remove the idling volume control screw. When the adjustment is tamper-proofed the tamperproofing cap must be removed to expose the screw.
12 Detach the adaptor from the carburetter body.
13 Mark up for re-assembly purposes then remove the throttle butterfly disc followed by the throttle spindle and linkage if required.
14 Remove the 'O' ring seal from the choke venturi tube.

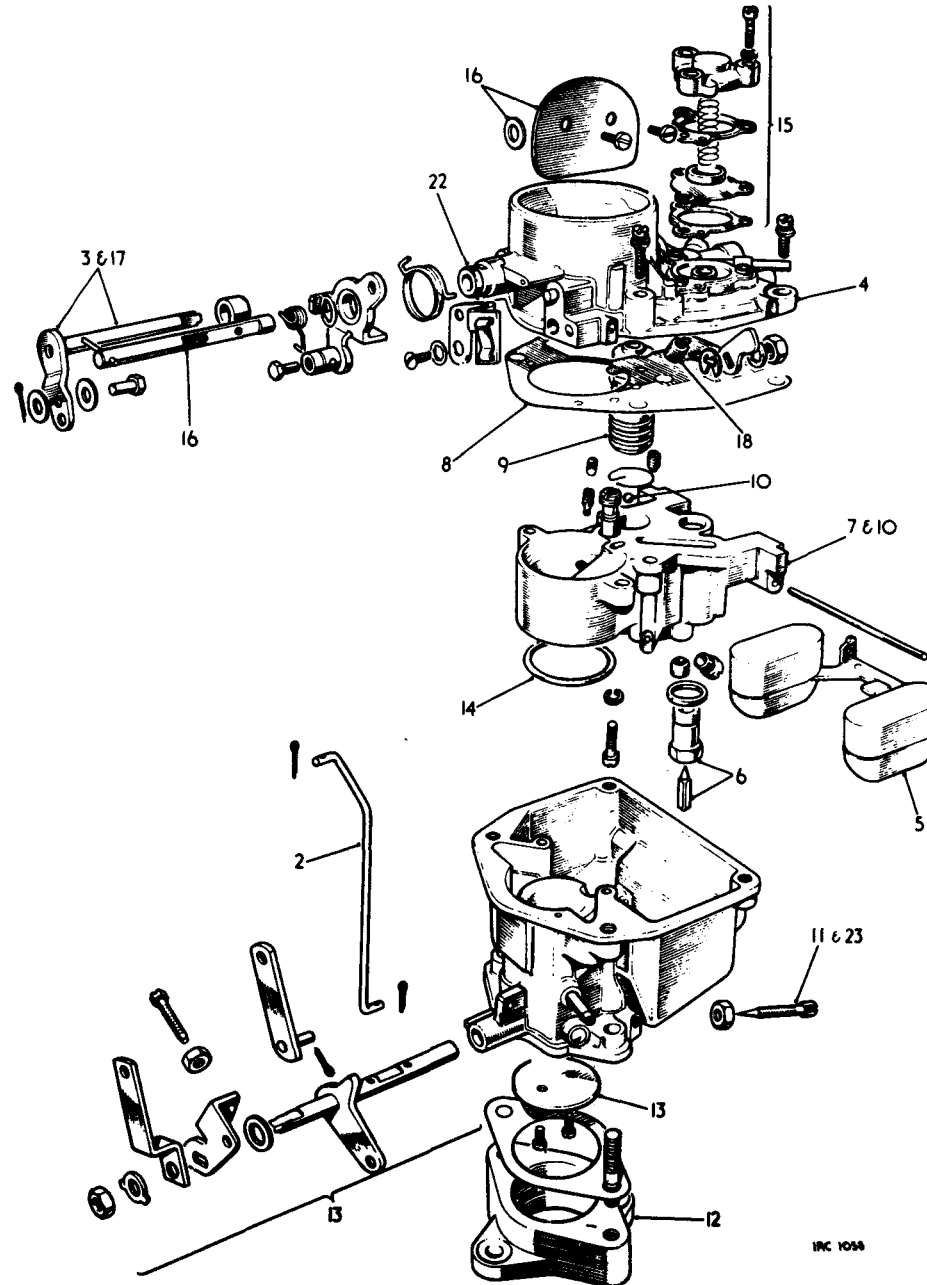

Carburetter top cover, dismantling

15 Dismantle the economy valve assembly, taking care to retain the diaphragm spring.
16 If required remove the choke butterfly (after making up) followed by the choke spindle, taking care to retain the thin washer.
17 Remove the spindle and lever for the accelerator pump.
18 Remove the ventilation screw for the choke.

Inspecting and cleaning

Special Notes

19 Carburetter cleaning.
When cleaning fuel passages do not use metal tools (files, scrapers, drills, etc.) which could cause dimensional changes in the drillings or jets. Cleaning should be effected using clean fuel and, where necessary, a moisture-free air blast.
20 Joint faces.
If the joint faces on the emulsion block, top cover or carburetter body show any signs of distortion or the edges are burred, these faces may be reclaimed by flattening, using fine grade abrasive cloth and a surface plate. Examine the faces for deep scores which would lead to leakage taking place when assembled.
21 Joint gasket and seals.
New gaskets and seals should be used throughout carburetter rebuild. A complete set of gaskets is available for replacement purposes.
22 Examine the throttle spindle bushes for wear, if oval or badly worn replace the carburetter body.
23 Examine the tapered end of the idling volume screw for wear and damage, replace as required.

continued

Reassembling**Carburettor top cover**

- 24 If previously dismantled, insert the choke spindle into its housing and at the same time refit the thin washer.
- 25 Locate the choke butterfly on the spindle and loosely retain with the two special screws. Operate the butterfly to centralise it on the spindle, then secure the screws and lock them by peening.
- 26 Engage the spring end on to the choke swivel lever.
- 27 Fit the economy valve gasket, diaphragm assembly and a further gasket to the top cover upper face, aligning the holes in the gaskets and diaphragm with the drilling in the top cover face.
- 28 Locate the spring in the seating on the diaphragm assembly, locate the valve cover spigot on the spring free end and align the drilling in the cover casting with the hole in the gasket. Push down on the cover, keeping it square to the diaphragm, then secure.
- 29 Fit the ventilation screw to the angled tapping in the top cover lower face.
- 30 Fit the spindle and lever for accelerator pump as illustrated.

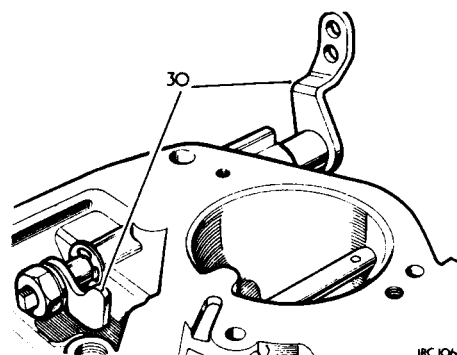
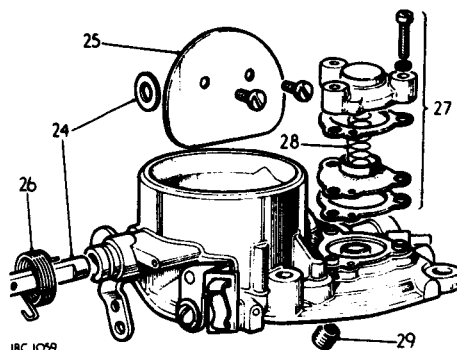
**Emulsion block, assembling**

- 31 Fit the blanked off jet.
- 32 Fit the slow running jet.
- 33 Fit the pump jet, followed by the pump jet tapping plug, to the tapping in the side of the emulsion block.
- 34 Fit the main jet and the enrichment jet to the emulsion block, the enrichment jet into the vertical tapping and the main jet into the angled tapping.

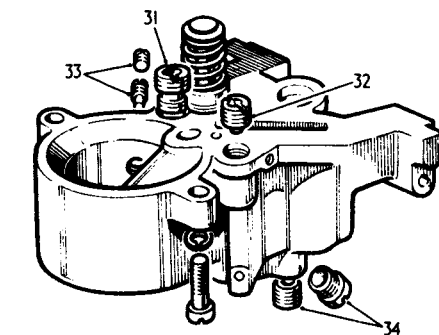
**Fitting the emulsion block to the carburettor top cover**

- 35 Position the gasket on the top cover joint face.
- 36 Apply a thin smear of clean lubricating oil to the accelerator pump piston and assemble, piston first, into its housing bore in the emulsion block.
- 37 Ensure that the accelerator pump spindle lever is positioned inboard to align with the accelerator pump plunger, position the emulsion block and accelerator pump assembly on the top cover joint face.
- 38 Ensure that the sealing washer for the needle valve housing is in good condition and fit the washer.
- 39 Fit the needle valve housing and the securing screws in the emulsion block. Do not fully tighten at this stage.
- 40 Check that the fuel passage drillings in the top cover are clear and not masked by misalignment of the gasket. Now fully tighten the emulsion block securing screws and needle housing.
- 41 Fit the needle valve into its seating in the needle valve housing. Check for leakage past the assembly by holding the needle valve on to its seating and blowing air into the fuel inlet pipe.

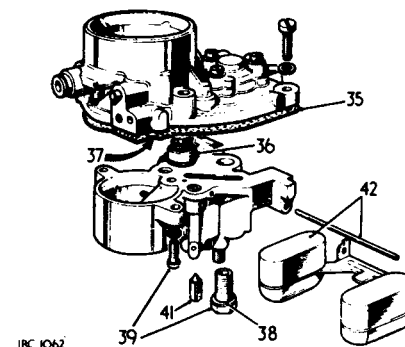
**Fitting the float assembly**

- 42 Position the float assembly on to the top cover, align the pin holes in the float carrier and emulsion block flange lugs and secure the float carrier with the hinge pin.
- 43 With the needle valve on its seating and the central tongue on the float carrier contacting on the needle valve, measure the distance between the gasket upper face and the highest point on the floats as illustrated.
- 44 The dimension required is 33 mm (1.3 in.). Any adjustment must be made by deflecting the central tongue which abuts the needle valve; adjustment must not be made by bending the float carrier arms.

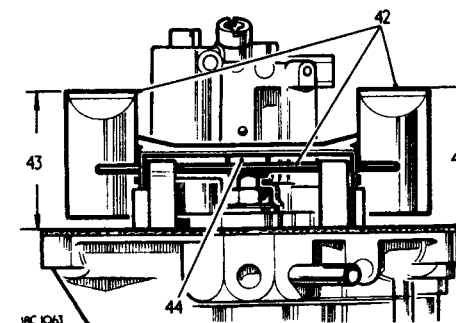

- 45 Assemble the throttle linkage to the spindle, insert the floating lever, plain washer, throttle stop, throttle lever, lock tab and securing nut as illustrated.
- 46 Fit the throttle spindle assembly to the carburetter then insert the butterfly into the spindle, aligning marks previously made, and loosely retain with the two special screws. Operate the butterfly to centralise it on the spindle, then secure the screws and lock them by peening.
- 47 Fit the carburetter adaptor to the carburetter body using a new gasket and tighten evenly.

Fitting top cover and emulsion block to carburetter body

- 48 Fit the 'O' ring seal to the seating around the top end of the venturi barrel. Ensure that the 'O' ring is correctly seated. **THIS IS VERY IMPORTANT AS POOR JOINTING WOULD CREATE POOR FUEL CONSUMPTION'**
- 49 Offer up the cover and emulsion block assembly to the carburetter body. Check that the 'O' ring seal around the venturi barrel is holding off the emulsion block, indicated by a small gap between the top cover gasket and carburetter body joint faces. This will ensure a compression seal on the 'O' ring when assembled.
- 50 Secure the assembly, evenly, to the carburetter body. Then replace the idling volume control screw.

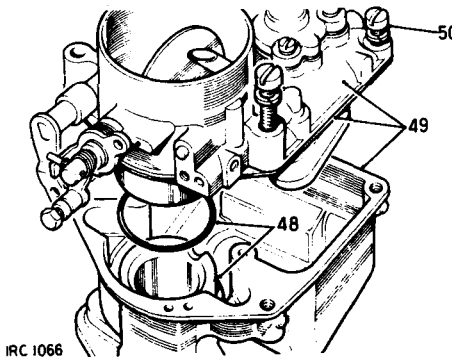
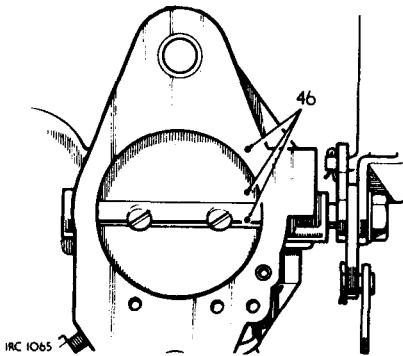
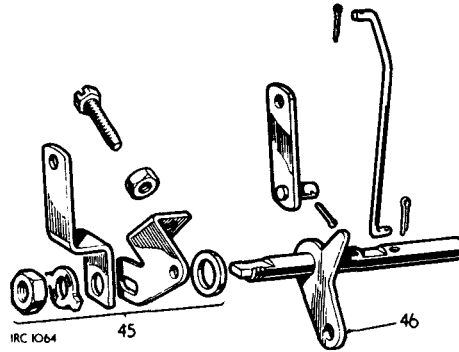

Carburetter linkage, reconnect

- 51 Connect the throttle relay lever to the hole furthest from the fulcrum on the accelerator pump spindle lever, using clevis pin, two plain washers and split pin.
- NOTE:** In cold ambient conditions use the hole nearest the fulcrum.
- 52 Fit the interconnecting link between choke operating tab and the floating lever on the throttle spindle and secure with split pins.

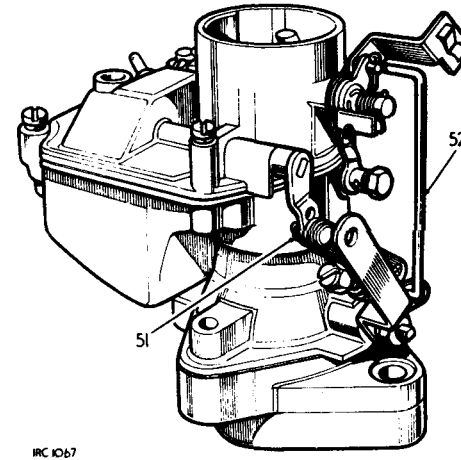

Fast-idle setting

- 53 Fully close the choke butterfly by actuating the choke operating tab. It should be possible to slide a 1,40 mm (0.055 in.) diameter drill between throttle butterfly edge and the carburetter body. If necessary, bend the interconnection link to achieve this condition.
- 54 Refit the carburetter. 19.15.09.

Carburetter, to set and adjust (See Note on Tamperproofing)

- 55 Before any attempt is made to set the idling speed the ignition timing must be correct and a thorough check should be made to ensure that the throttle linkage between the pedal and the carburetter is free and has no tendency to stick, also ensure full throttle operation.

- 56 Start the engine and run until warm, denoted by thermostat outlet pipe becoming warm to the touch. Continue running for a further five minutes to thoroughly stabilise engine temperature.
- 57 Adjust the throttle stop screw to obtain the correct engine idling speed of 500–550 rev/min.
- 58 Adjust the idling volume control screw until the engine runs smoothly and evenly. Recheck idle speed and correct as necessary. Recheck idling stability. It may be necessary to alternate adjustments between idling volume control screw and throttle stop screw to obtain the required idling setting. The idling volume control screw is then at the setting position required for all engine operating conditions. To confirm that the setting position selected is correct, turn the volume control screw in and out respectively from the setting position by approximately one-half turn; at these checking positions the engine note will alter and the engine running will become uneven. After checking, return the volume control screw to the correct setting position selected midway between the checking positions.

continued

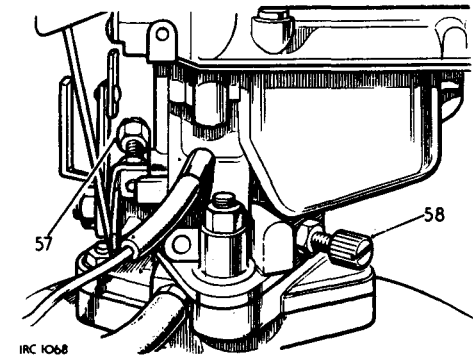

DATA

Float height setting	33 mm (1.300 in.)
Fast-idle setting	1,40 mm (0.055 in.) between throttle butterfly edge and carburetter barrel
Idling speed	500-550 rev/min
Idling speed (with emission control)	750-800 rev/min

2.6 litre 6-cylinder engines
 Special Tools: ERC 3692
 ERC 3786
 S 353

Any adjustments must be carried out as follows with the engine in a fully installed condition at normal operating temperature with the ignition timing correct.

NOTE**Tamperproof Carburetters**

Where tamperproofing or emission control equipment is fitted, any adjustment to carburetter mixture and/or slow running control must conform to local territory exhaust emission legislation.

2¼ litre Petrol

Special tools required: ERC 3696
 ERC 3786

Should adjustment be required, this must only be carried out with the engine in a fully installed condition as follows.

- 1 Ensure that the engine is to normal operating temperature with correct ignition timing.
- 2 Pierce and prise out the cap and using tool ERC 3692, slacken the locknut on the idle screw. Set to the correct idle speed and just nip the locknut.
- 3 Recheck the ignition timing if dynamic tuning is used.
- 4 Using tool ERC 3692, slacken the locknut on the mixture screw and adjust to obtain the correct exhaust C.O. readings and just nip the locknut.
- 5 Recheck the idle speed.
- 6 When the idle speed and CO readings are correct to specification, tighten the locknuts on both the idle speed and mixture screws. Recheck speed and CO after tightening.
- 7 Fit the correct cap to the shrouds surrounding the adjustment screws using tool ERC 3786.

Idle mixture adjustment

- 1 Remove the piston damper.
- 2 Insert tool S 353 into the piston guide rod, ensuring that the peg on the outer barrel of the tool is located in the slot to prevent the piston twisting with consequent damage to the diaphragm.
- 3 Push down the allen key to locate in the hexagon of the metering needle housing.
- 4 Turn the tool in a clockwise direction to richen the mixture, and anti-clockwise to weaken.

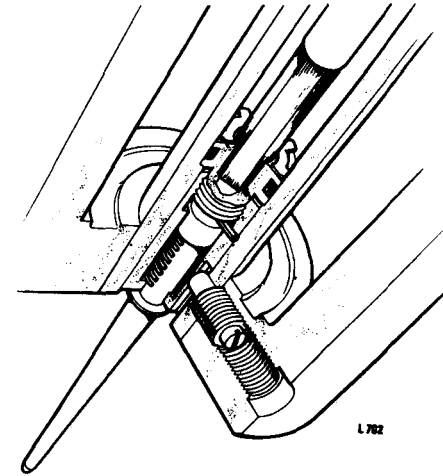
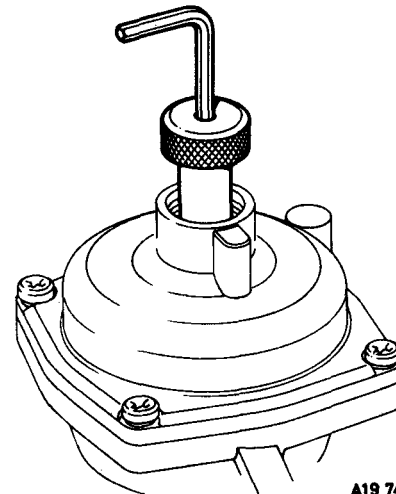

NOTE: The adjusting tool should be removed from the guide rod after every adjustment to allow the engine to recover stability which is upset due to the piston being depressed during adjustment. Running the engine at 2000 rev/min for a few seconds will aid this recovery.

- 5 Refit the piston damper. Run the engine at 2000 rev/min for about 20 secs before taking the final speed and exhaust CO readings. Slight adjustment to mixture and/or speed may be required after this operation.

The metering needle, will normally be set with the shoulder of the needle flush with the face of the piston, this is termed the datum position. If difficulty is experienced with carburation the needle should be set to this datum for investigation. When using the adjusting tool, a positive stop will be evident when the needle is in the fully rich position. In the anti-clockwise direction there is no stop, and it is possible to disengage the needle from the adjusting screw, if more than two turns are made from the datum position.

Should this occur, the needle can be re-engaged by applying light pressure in the upward direction, to the shoulder of the needle at the piston face, while turning the adjusting tool in a clockwise direction.

Idle speed adjustment

To adjust the idle speed the following procedure must be followed.

- 1 Ensure that the throttle jack solenoid is operative with the engine running.
- 2 Pierce and remove the cap and slacken the locknut on the round head screw, located on the lever actuated by the solenoid plunger (using tool ERC 3692).
- 3 Using the screwdriver incorporated in the tool, engage end of the screw and adjust against the solenoid plunger until the correct idle speed is obtained.

IMPORTANT

Under no circumstances can the normal idle speed screw on the carburetter casting be used for this operation.

- 4 Tighten the locknut, recheck exhaust CO and speed settings.
- 5 Fit the correct cap to the nylon shroud surrounding the adjusting screw using tool ERC 3786.

Fast Idle

Operation of the choke from on to off should result in a fast idle speed of 1200 r.p.m. \pm 50 when the choke control is approximately 0.5 in. from the fully in position.

Should adjustment be required the following procedures must be used.

- 1 Remove the carburetter from the engine. 19.15.09.
- 2 Put the starter unit adjusting pin in the full choke position (pin in the groove).
- 3 With the starter unit held in the full choke position, it should be just possible to insert a 1,0 mm (No. 61) drill between the top edge of the throttle plate and the throttle barrel wall.
- 4 To adjust the setting, release the locknut on the dome head screw fitting in the throttle lever that contacts the starter unit cam, adjust the screw to obtain the required setting, tighten the locknut, and recheck the gap.
- 5 Replace the adjusting pin in the reduced choke position.

Poppet Valve

This assembly is preset and non adjustable if malfunction is suspected the carburetter must be changed.

CARBURETTER, Zenith type 175CD 2S

Overhaul and adjust 19.15.17

Dismantling

- 1 Remove the carburetter. 19.15.09.

Removing the piston assembly

- 2 Remove the oil cap and damper.
- 3 Remove the top cover and spring.
- 4 Withdraw the air valve, shaft and diaphragm assembly.
- 5 Remove the metering needle, retained by a locking screw (where applicable use Tool S 353 anti-clockwise to remove needle).
- 6 Remove the diaphragm from the air valve.

Removing the float chamber

- 7 Remove and dismantle the jet assembly (basic carb. only).
- 8 Remove the float chamber and gasket.
- 9 Unclip the float and arm complete with the spindle.
- 10 Remove the needle valve and washer from the carburetter body.

Dismantling the carburetter body

- 11 Add location marks to the throttle butterfly and spindle.
- 12 Remove the throttle butterfly.
- 13 Remove the throttle lever.
- 14 Withdraw the throttle spindle.
- 15 If required, remove the throttle stop and fast idle lever.
- 16 Remove the cold start assembly.
- 17 Dismantle the cold start assembly, but DO NOT remove the discs from the spindle.

Cleaning and inspecting

Carburetter cleaning

- 18 When cleaning fuel passages do not use metal tools (files, scrapers, drills, etc.) which could cause dimensional changes in the drillings or jets. Cleaning should be effected using clean fuel and where necessary a moisture-free air blast.

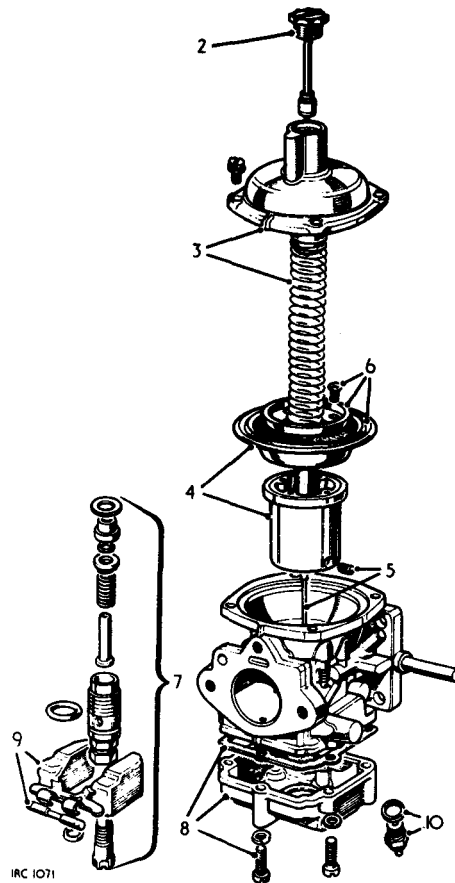

IRC 1071

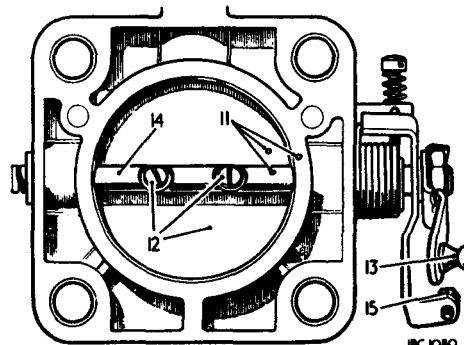

IRC 1080

Joint Faces

- 19 Examine the faces for deep scores which would lead to leakage taking place when assembled.

Joint gasket and seals

- 20 New gaskets and seals should be used throughout carburetter rebuild. A complete set of gaskets is available for replacement purposes.
- 21 Inspect metering needle, it is machined to very close limits and should be handled with care. Examine for wear, bend and twist, replace if necessary.

Diaphragm

- 22 In common with other products made from rubber compounds, any contact of the diaphragm with volatile cleaners should be avoided, use only clean rag. Examine for damage and deterioration.
- 23 Examine float, for puncture or damage and chamber for corrosion, retaining clips for wear.
- 24 Examine cold start bushes for wear, renew starter cover as necessary.
- 25 Examine clamping screw for two positions, renew as necessary.

Reassembling

Cold start, control

- 26 Place the spring on the cold start spindle.
- 27 Fit the spring retaining clip.

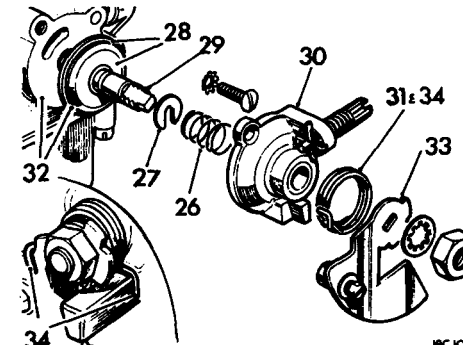

IRC 1072

- 28 Check that the discs slide easily on the spindle.
- 29 Place the cold start spindle on the starter face.
- 30 Place the starter cover in position.
- 31 Fit the return spring over the spindle.
- 32 Rotate the spindle until the oval port in the end disc is aligned with the oval port in the starter face.
- 33 Fit the cold start lever.
- 34 Engage the return spring over the lug on the starter cover and the back of the cold start lever.
- 35 Fit the cold start assembly to the carburetter body.
- 36 Check assembly for ease of operation.

Throttle spindle

- 37 Position the throttle spindle with the recessed end uppermost.
- 38 Position the screw head flats on the spindle toward the operator.
- 39 Place the return spring over the recessed end of the spindle.
- 40 Fit the throttle stop and fast idle lever.
- 41 Fit the throttle lever.
- 42 Secure the assembly with a bushed washer, tab washer and nut. Engage the tab washer.
- 43 Insert the throttle spindle from the cold start side of the carburetter body fitting the throttle return spring on the fast idle adjustment holder.

continued

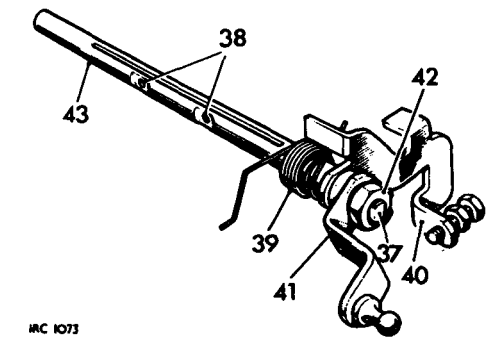

IRC 1073

- 44 Tension the spring half a turn.
- 45 Fit the throttle butterfly, maintaining the previously marked alignment. Leave the retaining screws loose.
- 46 Actuate the throttle several times to centralise the butterfly, then tighten the retaining screws and lock by peening ends.
- 47 Fit the throttle stop adjusting screw until it touches the stop, then turn a further one and a half turns (where the throttle stop screw is tamperproofed, and a throttle jack is used, this screw should remain unaltered and the butterfly completely closed).

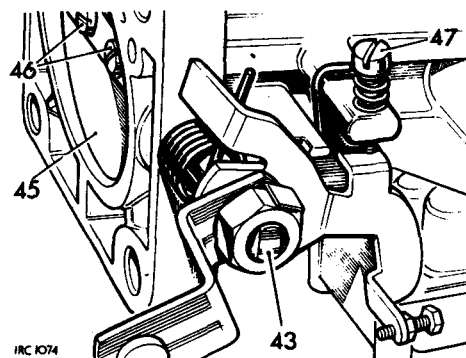

Float chamber

- 48 Fit the needle valve and washer.
- 49 Locate the spindle into the float arm and engage the assembly in the retaining clips.
- 50 With the needle valve on its seating and the tab on the float carrier contacting the needle valve, measure the distance between the carburetter flange face and the highest point on the floats.
- 51 The dimension required for correct float level is 16 to 17 mm (0.629 to 0.669 in.). Adjust by bending the tab on the float carrier or fitting an additional washer under the needle seating.

NOTE: The float carrier tab must be maintained at right angles to the needle in the closed position.

- 52 Fit the float chamber and gasket but do not fully tighten the screws at this stage.

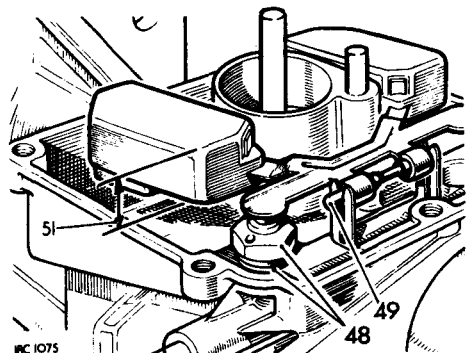

Jet assembly (Basic Carburetter)

- 53 Fit the 'O' ring into the guide bush.
- 54 Fit the 'O' ring over the jet orifice carrier.
- 55 Fit the 'O' ring over the adjusting screw.
- 56 Place the spring over the jet orifice.
- 57 Fit the guide bush (thin flanged) onto the jet orifice.
- 58 Fit the top bush to the jet orifice.
- 59 Place a plain washer onto the top bush.
- 60 Place the jet orifice assembly into the carrier. Insert the assembly through the float chamber and fully tighten, then tighten the float chamber screws.
- 61 Fit the adjusting screw and adjust the jet orifice until it is in line with the top of the bushing.

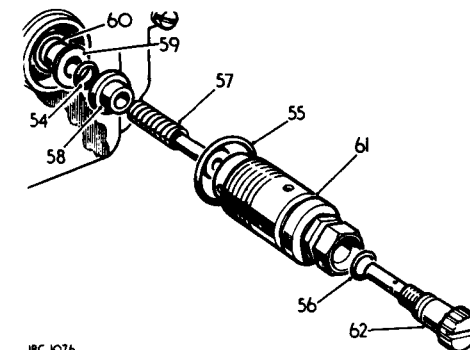

Air valve, shaft and diaphragm

- 62 Where applicable insert needle housing assembly into the bottom of the air valve.

Fit tool S 353, turning clockwise to engage threads of needle valve assembly with adjusting screw; continue turning until slot in needle housing is aligned with grub screw.

Tighten grub screw.

NOTE: The grub screw does not tighten on the needle housing but locates into the slot. This ensures that, during adjustment, the needle will remain in its operating position, i.e. biased, by a spring in the needle housing, towards the air cleaner side of the carburetter.

- 63 Locate the diaphragm onto the air valve with the tab engaged in the recess.
- 64 Fit the diaphragm retaining ring.
- 65 Locate the metering needle into the air valve.
- 66 Align the needle shoulder with the top surface of the air valve shaft.
- 67 Secure the needle in position.

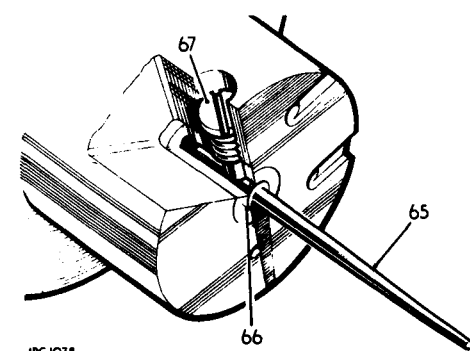
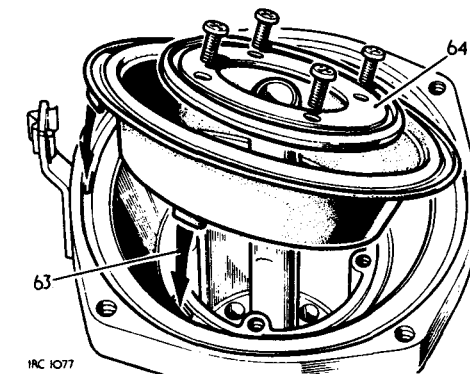

Jet centralisation (basic carburetter)

- 68 Locate the air valve and needle assembly into the carburetter and allow the air valve to bottom on the jet bridge. **DO NOT** push the valve down. If the valve does not bottom, unclamp the jet assembly sufficient to allow the valve to bottom. In this position, ensure that the locating tab on the diaphragm locates in the recess on the carburetter body.
- 69 Fit the air valve return spring and carburetter top cover.
- 70 Lift the air valve and tighten the jet assembly fully.
- 71 Slacken off the whole jet assembly approximately half a turn to release the orifice bush.
- 72 Allow the air valve to fall, if necessary assist by inserting a pencil in the dashpot. The needle will automatically centralise the jet orifice.
- 73 Slowly tighten the jet assembly, checking frequently that the needle remains free in the orifice. Check by raising the air valve approximately 6 mm (0.250 in.) and allowing it to fall freely. The air valve should stop firmly on the bridge.
- 74 Fill the dashpot in the air valve to within 6 mm (0.250 in.) of the top of the air valve shaft with SAE 20 engine oil.
- 75 Fit the damper assembly to the dashpot and top cover.

Fast idle adjustment, carburetter removed

- 76 Set the cold start adjuster fully outward.
- 77 Slacken the fast idle adjusting screw.
- 78 Hold the cold start cam lever in the maximum position.
- 79 Adjust the fast idle adjusting screw against the cam lever to obtain a 1,0 to 1,1 mm (0.039 to 0.043 in.) clearance between the top edge of the throttle butterfly and the carburetter barrel wall.
- 80 Measure the clearance using feeler gauges or a 1,1 mm (No. 57) diameter drill shank.
- 81 Secure the fast idle adjusting screw locknut without disturbing the adjustment.
- 82 Refit the carburetter 19.15.09.

Slow running adjustment

- 83 Run the engine until normal operating temperature is obtained. If necessary adjust slow-run screw to give the correct idling speed.
- 84 Lift the carburetter piston approximately 1 mm (0.031 in.) by removing the air cleaner to gain access to the carburetter piston.
- 85 If the engine speeds up immediately the mixture is too rich and the jet adjustment screw must be turned anti-clockwise, thus weakening the mixture; if the engine stops immediately, the mixture is too weak and the jet adjustment screw should be turned clockwise to enrich the mixture. If the engine just falters and continues to run unevenly the adjustment is correct.
- 86 Finally adjust the slow-run screw to get a smooth idling speed.

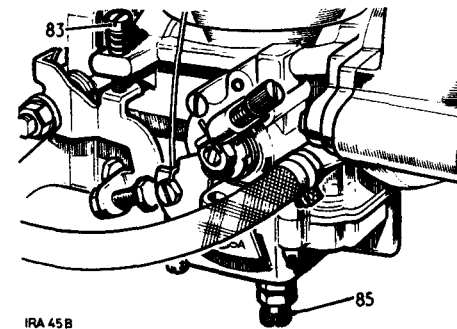
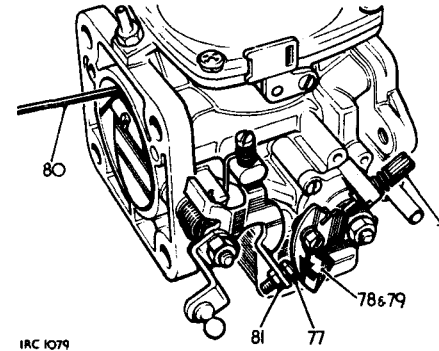

Fast-idle adjustment, carburetter fitted

- 87 Operate fully the cold start control.
- 88 Adjust the fast-idle stop screw to obtain an engine speed of 1,000 to 1,200 rev/min.
- 89 Return the cold start control and ensure that the fast-idle stop screw is clear of the cam lever.

Low temperature starting

- 90 For starting at temperatures down to -18°C (0°F) push and turn the spring-loaded choke adjustment screw so that the peg is at right-angles to the slot as illustrated. Leave in this position. When starting at temperatures below -18°C (0°F) turn the screw until peg is recessed in slot.

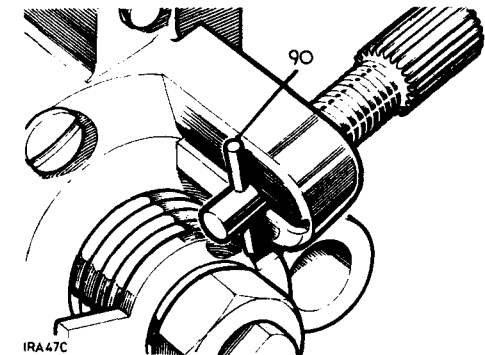

DATA

Float height	16 to 17 mm (0.629 to 0.669 in.)
Fast-idle setting, carburetter removed	1,0 to 1,1 mm (0.039 to 0.043 in.)
Fast-idle setting, carburetter fitted	1,000 to 1,200 rev/min
Idling speed	500 rev/min

16 to 17 mm (0.629 to 0.669 in.)
1,0 to 1,1 mm (0.039 to 0.043 in.)
clearance between throttle butterfly top edge and carburetter barrel
1,000 to 1,200 rev/min
500 rev/min

THERMOSTAT SWITCH for cold start warning light, Petrol models

Remove and refit 19.15.50

Removing

- 1 Locate the switch at the front of the cylinder head, RH side for 2.6 litre models and LH side for 2½ litre models.
- 2 Disconnect the electrical lead.
- 3 Remove the fixings.
- 4 Withdraw the switch and joint washer. If necessary, disconnect and move aside the crankcase breather pipe to obtain clearance for removal.

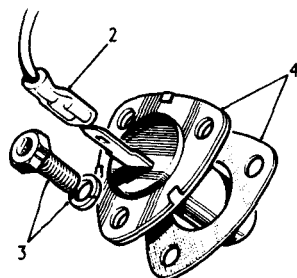

2RC 41

Refitting

- 5 Reverse instructions 1 to 4.

THROTTLE LINKAGE

Remove and refit 19.20.07

General

The accelerator controls vary between different models; the following instructions are generally applicable but reference should be made to the exploded views and descriptions of accelerator controls for detail variations, refer to 19.00.00.

NOTE: On 2.6 litre models, access to the throttle linkage at the rear of the engine is best obtained by removing the gearbox tunnel cover. 76.25.07.

Removing

- 1 Disconnect the linkage return springs.
- 2 Disconnect the linkage adjacent to the pedal box.
- 3 Disconnect the linkage at the carburettor or fuel distributor pump.
- 4 Remove the RH retaining bracket from the engine compartment dash.
- 5 Withdraw the throttle linkage complete.

Refitting

- 6 Reverse 1 to 6 leaving the pinch bolts loose at this stage.
- 7 Depress the throttle pedal onto the stop on the toe box floor.
- 8 Hold the throttle linkage in the fully open position.
- 9 Tighten the linkage pinch bolts and release the pedal and linkage.
- 10 If necessary adjust the throttle pedal stop on the toe box floor and the return stop at the toe box to permit full and unrestricted throttle opening.

NOTE: When replacing or refitting the accelerator cable to the pedal assembly, care must be taken to ensure that the yoke end of the cable assembly pivots freely about the clevis pin and accelerator pedal. A tight fitting accelerator cable/pedal assembly will cause the cable to flex about the point where it is joined to the yoke and could adversely effect the life of the cable.

Diesel models with servo-assisted brakes

- 11 The vacuum supply for servo assistance is obtained via a non-return valve positioned downstream of a butterfly valve fitted to the induction manifold.
- 12 A vacuum supply is built up in the vacuum reservoir tank and servo unit during engine over-run conditions, that is with the accelerator linkage quickly closed on deceleration.
- 13 The linkages must be set such that the manifold butterfly will open slightly in advance of the fuel distributor pump linkage during acceleration, otherwise overfueling will result.

Linkage setting

- 14 Move the engine speed hand control fully to the idle position.
- 15 Ensure that the accelerator linkage is fully in the idle position.
- 16 Remove the air inlet hose from the induction manifold to obtain access to the manifold butterfly valve.
- 17 Ensure that the butterfly valve is fully closed, if necessary, adjust at the valve linkage pinch bolt at the cross shaft.
- 18 Ensure that clearance exists between the front arm of the cross shaft lever and the fuel distributor pump link.
- 19 Adjust at the lever pinch bolt as required to obtain the clearance.
- 20 Refit the air inlet hose.

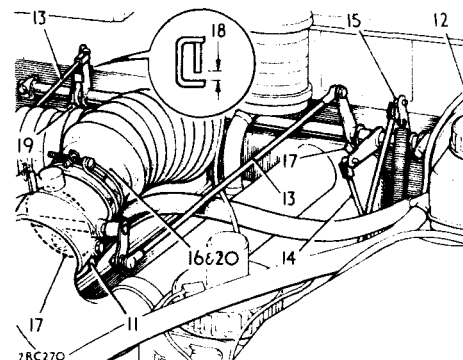

2RC 270

COLD START CONTROL CABLE, vehicles without steering column lock

Remove and refit 19.20.26

Removing

- 1 Disconnect the battery earth lead.
- 2 Disconnect the inner and outer control cables at the carburettor.
- 3 Slacken the locknut and release the retainer screw fixing the switch unit to the control cable.
- 4 Disconnect the white/blue lead from the front connector blade and the white/yellow lead from the rear blade.

- 5 Withdraw the switch unit.
- 6 Withdraw the cable grommet at the engine compartment dash.

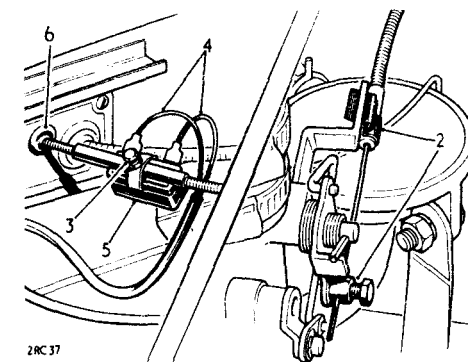

2RC 37

- 7 Remove the fixings and withdraw the steering column switch shrouds to gain access to the control cable.
- 8 Remove the locknut and shakeproof washer fixing the outer cable to the mounting bracket.
- 9 Push the control forward to clear the hole in the mounting bracket.
- 10 Lift the control and pass the inner cable through the slot provided in the bracket.

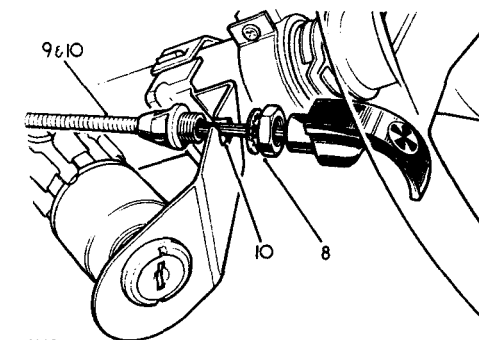

2RC 38

- 11 Withdraw the control cable assembly complete.

Refitting

- 12 Reverse instructions 1 to 11; ensure that the control knob is fully forward and the choke mechanism is fully open before clamping the inner cable at the carburettor.

COLD START CONTROL CABLE, for vehicles fitted with steering column lock

Remove and refit 19.20.26

Removing

- 1 Carry out items 1 to 6 of the preceding operation as described for vehicles without steering column lock.
- 2 Remove the fixings and withdraw the steering column upper and lower shrouds.
- 3 Remove the cable housing locating screw,
- 4 Withdraw the control cable and housing complete from the steering column lock.
- 5 Remove the retaining circlip.
- 6 Withdraw the control cable assembly complete.

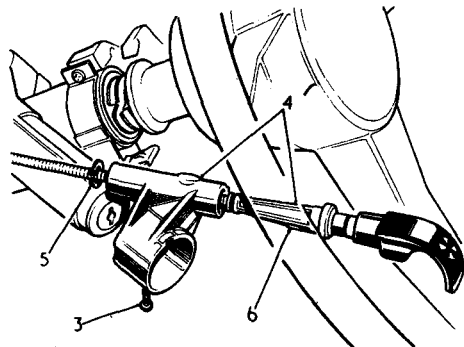

2RC 45

Refitting

- 7 Reverse instructions 1 to 6 and check the control operation.

HAND CONTROL, ENGINE SPEED, 2¼ litre Diesel models

Remove and refit 19.20.29

Removing

- 1 Disconnect the control rod lower end from the pivot lever in the engine compartment.
- 2 Remove the trim cover from the quadrant plate.
- 3 Remove the fixings, quadrant plate to dash.
- 4 Withdraw the quadrant plate and hand control lever.
- 5 Withdraw the sealing pad.
- 6 If required, make alignment marks for reassembly purposes, slacken the pinch bolt and withdraw the hand lever from the pivot lever and quadrant plate.

Refitting

- 7 Reverse instructions 1 to 6. If adjustment is required, proceed as instructions 8 to 11.
- 8 Move the hand control lever to the minimum speed position (LH side of the quadrant).
- 9 Ensure that the fuel distributor pump linkage is in the idle speed position.
- 10 Check for a minimum clearance between the lift arm on the actuator lever and the cross shaft relay lever.
- 11 To adjust, slacken the hand control lever pinch bolt and rotate the pivot lever in the required direction. Tighten the pinch bolt.

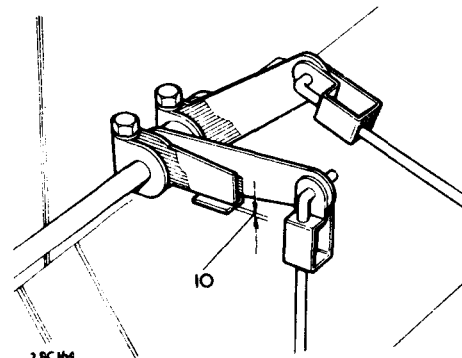

2RC 164

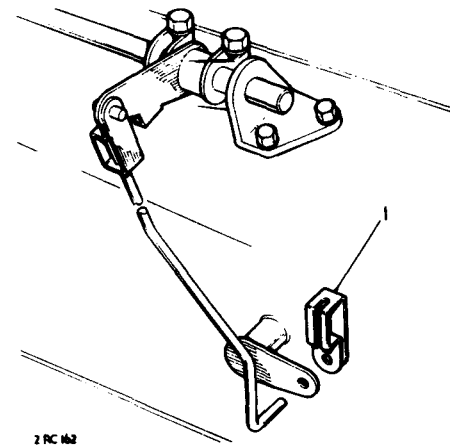

2RC 162

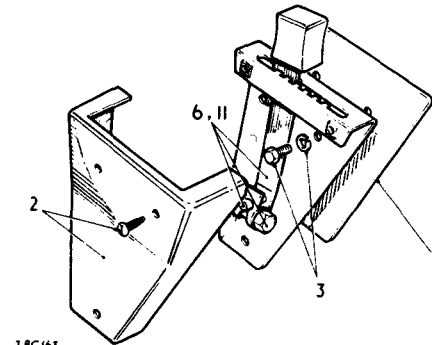

2RC 163

- 5 Remove the fixings and move aside the steering column upper and lower shrouds to gain access to the control cable.
- 6 Remove the locknut and shakeproof washer fixing the outer cable to the mounting bracket.
- 7 Push the control forward to clear the hole in the mounting bracket.
- 8 Lift the control and pass the inner cable through the slot provided in the bracket.
- 9 Withdraw the control cable assembly complete.

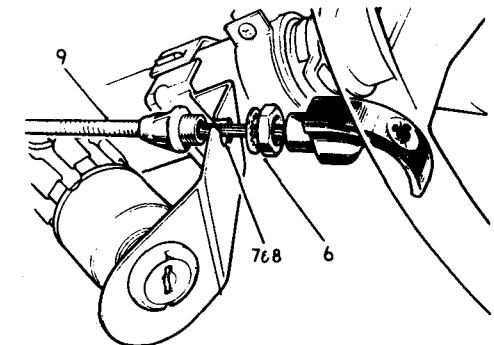

2RC 46

Refitting

- 10 Reverse instructions 1 to 9; ensure that when the control is operated, full movement is obtained at the injection pump cut-off lever.

ENGINE STOP CONTROL CABLE, vehicles without steering column lock.

Remove and refit 19.20.32

Removing

- 1 Disconnect the injection pump cut-off lever return spring.
- 2 Disconnect the control inner cable at the cut-off lever.
- 3 Disconnect the control outer cable at the support bracket.
- 4 Withdraw the cable grommet at the engine compartment dash.

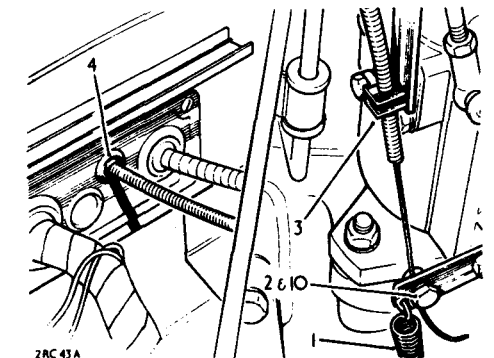

2RC 43A

ENGINE STOP CONTROL CABLE, vehicles fitted with steering column lock

Remove and refit 19.20.32

Removing

- 1 Disconnect the injection pump cut-off lever return spring.
- 2 Disconnect the control inner cable at the cut-off lever.
- 3 Disconnect the control outer cable at the support bracket.
- 4 Withdraw the cable grommet at the engine compartment dash.
- 5 Withdraw the control outer cable from the inner cable.
- 6 Remove the steering column upper and lower shroud fixings and move aside the shrouds.
- 7 Slacken the control rear stop screw sufficient to allow the internal stop pin to clear the screw end.
- 8 Withdraw the control knob and inner cable assembly.

Refitting

- 9 Reverse 2 to 8 but do not secure the control inner cable at this stage.
- 10 Move the control knob to the 'engine stop' position, that is with the cable ferrule abutting the internal stop lever in the control housing.
- 11 Move the injection pump cut-off lever fully into the fuel cut-off position.
- 12 Secure the control inner cable to the fuel cut-off lever.
- 13 Reverse 1. Ensure that the stop control moves fully forward into the 'engine start' position when the electrical services and starter key is inserted and turned clockwise to the II position.
- 14 Ensure that with the stop control pulled fully rearwards and the starter key removed, the stop control remains engaged in the 'engine stop' position.

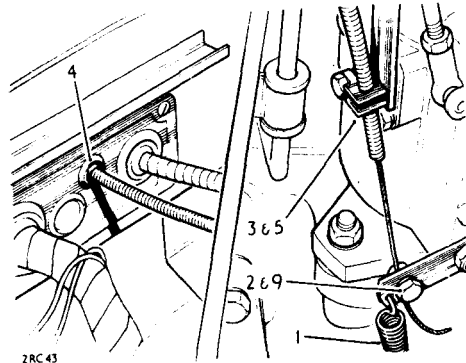

2RC 43

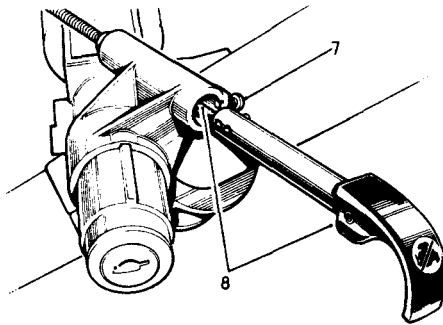

2RC 44

FUEL DISTRIBUTOR/INJECTION PUMP

Remove and refit 19.30.07

Service tool: 605863, Timing gauge

Removing

- 1 Remove the bonnet panel. 76.16.01.
- 2 Remove the air cleaner. 19.10.04.
- 3 Disconnect the battery earth lead.
- 4 Disconnect the engine stop cable.
- 5 Disconnect the stop lever return spring.
- 6 Disconnect the accelerator linkage at the securing clip.
- 7 Remove the fuel pipes, distributor pump to injectors.
- 8 Disconnect the remaining fuel pipes from the distributor.
- 9 Remove the distributor pump fixings.
- 10 Withdraw the distributor pump.
- 11 Withdraw the distributor pump drive shaft.

Refitting and timing procedure

- 12 Remove the engine rocker cover.
- 13 Slacken the fixings and move aside the inspection cover on the flywheel housing to expose the timing pointer adjacent to the flywheel.
- 14 Turn the crankshaft in the direction of rotation until both valves of number one cylinder are closed and the piston is ascending the bore on the compression stroke.
- 15 Continue to turn the crankshaft until the timing pointer aligns with the 13° mark on the flywheel, that is 13° BTDC. This must be done carefully. If the flywheel is inadvertently turned too far and the timing mark goes past the pointer, do not turn the flywheel back, but repeat the operation. Ensure that a correct line of vision is taken when lining up the timing marks. An incorrect line of vision can result in the timing being 1° to 2° out.
- 16 The master spline on the driving gear should now be approximately 20° from the centre line of engine measured from the front end, that is, at the 4 o'clock position.

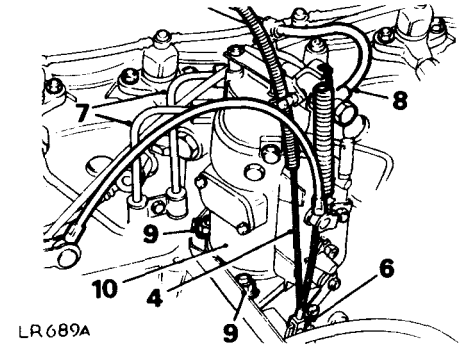

LR 689A

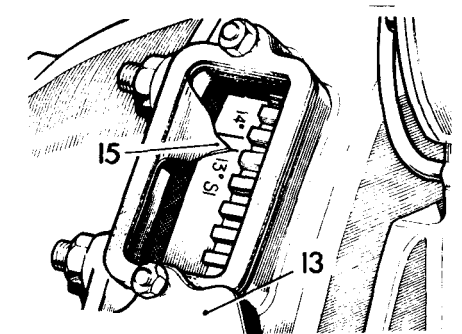

1123

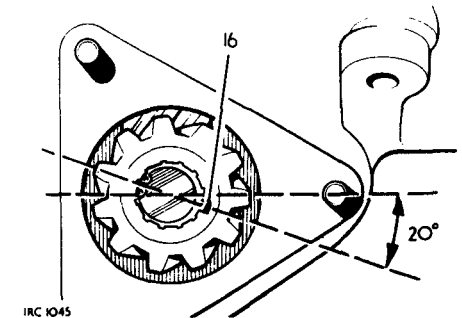

IRC 1045

- 17 Insert the timing gauge, 605863, into the driving gear, then twist gauge in a clockwise direction to take up backlash and any wear in the gears.
- 18 Hold in this position, then, if necessary, slacken off bolts retaining the timing pointer on the side of the cylinder block. Adjust pointer so that it coincides with the line on the timing gauge, as illustrated, then retighten the bolts.
- 19 Remove timing gauge.
- 20 Rotate the driving gear on the distributor pump so that the master spline lines up with the master spline on the engine driving gear.
- 21 Fit the pump drive shaft, longer splines last, to the engine driving gear, engaging the master spline.
- 22 Fit the distributor pump to the engine engaging the master splines on the pump and the drive shaft. Do not tighten the fixings at this stage.
- 23 Align the vertical mark on the pump flange with the pump timing pointer, then tighten the pump fixings.
- 24 Reverse 3 to 8 and 12 and 13.
- 25 Prime the fuel system. 19.50.01.

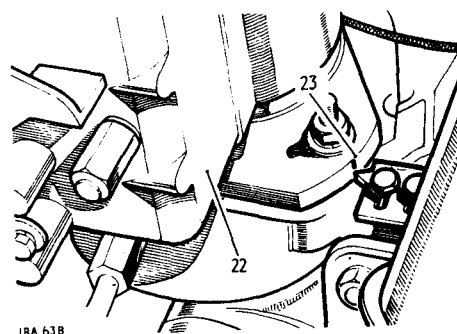
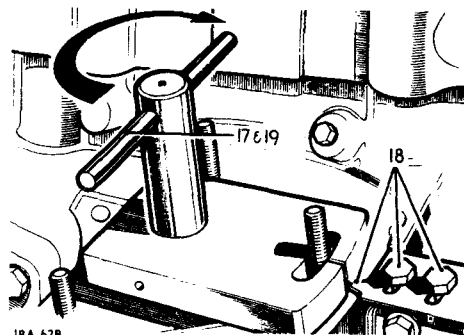

The following instructions, 26 to 36, describe an alternative method of timing the fuel injection pump using service timing gauge MS 67 B.

- 26 Follow instructions 1 to 16 above.
- 27 Using Service tool MS 67 B, assemble the scribing arm of the tool to the tool body.
- 28 Set gauge by loosening knurled screws and sliding bracket around until chamfered edge aligns with the required angle of 22°; tighten knurled screw in this position.
- 29 Insert tool MS 67 B into vacant injection pump position and engage tool gear into injection pump drive splines.
- 30 Release centre shaft retaining screw and slide tool body along centre shaft until body engages injection pump drive gear hub. Lock shaft retaining screw.
- 31 Apply gentle clockwise pressure to take up backlash or wear in gears; retain in this position.
- 32 Slacken off timing pointer bolts. Adjust timing pointer so that it aligns with scribing arm on tool. Tighten timing pointer bolts.
- 33 Remove tool MS 67 B.
- 34 Rotate driving gear on distributor pump so that master spline lines up with master spline on driving gear.
- 35 Offer pump to engine, ensuring that the timing mark on the pump flange coincides with the timing pointer.
- 36 Tighten the injection pump retaining nuts.

NOTE: When the distributor pump is timed as detailed above, that is, with the timing pointer on the engine altered to take up backlash and wear on the gears, it ensures that optimum distributor pump timing is achieved.

Should there be any fall-off of power during the life of the engine, retiming the distributor pump to take up gear wear could well make a significant improvement to engine performance, provided the engine is generally in good condition.

- 37 Reverse instructions 3 to 8 and 12 to 13.
- 38 Prime the fuel system. 19.50.01.

continued

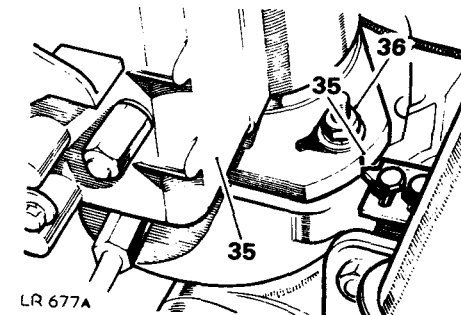
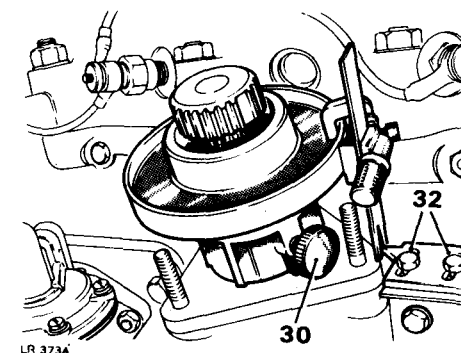
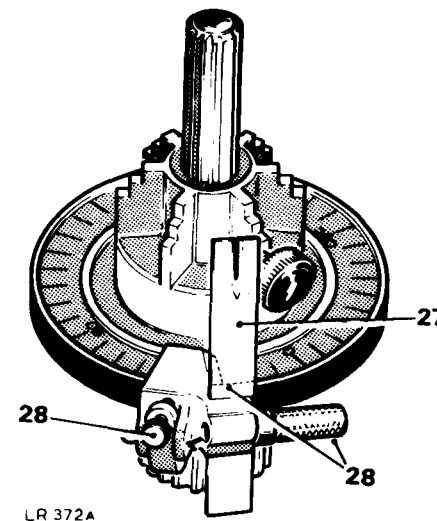

Setting the distributor pump control screws

- 39 On distributor pumps with the maximum output control screw sealed, the control screw setting must not be altered. Adjustment is allowed to the slow running control screw only.
- 40 However, when a new or reconditioned distributor pump is to be fitted, it will be found that the slow running control screw is loosely attached to the distributor pump and that the maximum output control screw is not sealed.
- 41 It is necessary, therefore, after the distributor pump has been assembled to the engine, first to fit the slow running control screw and then adjust both screws as detailed in instructions 42 to 47.

Slow running control screw adjusting

- 42 Adjust the control screw until the engine slow running speed is 590 ± 20 rev/min. This may be checked using a suitable revolution counter, or by adjusting the control screw until the lowest engine speed consistent with smooth, even running is achieved.
- 43 To adjust the slow running control screw, proceed as follows:
 - a Check engine speed with revolution counter.
 - b Slacken adjusting screw locknut and screw inwards to increase speed and outwards to decrease.
 - c When a slow running speed of 590 ± 20 rev/min has been obtained, tighten locknut.
 - d Remove revolution counter.

Maximum output control screw adjusting

- 44 Adjust the control screw, where necessary, until the engine maximum speed is 4200 ± 20 rev/min. This may be checked using a suitable revolution counter, or by road test; the road speed equivalent of 4,200 rev/min being 48 mph (77 kph) in third gear.
- 45 When maximum engine speed of $4,200 \pm 20$ rev/min has been obtained, tighten locknut.

- 46 Fit the adjusting screw collar.
- 47 Wire lock and seal the screw collar.
- 48 Reverse instructions 1 and 2.

FUEL INJECTION PUMP

Altitude compensation for fuel injection pump

When vehicles equipped with diesel engines are operated at high altitude it is recognised that the reduced air density causes a reduction in the weight of air drawn into the engine cylinders, which results in incomplete combustion of the injected fuel at full throttle, unless this is reduced in proportion to the reduction in air density.

To compensate for these variations and to avoid excessive fuel consumption, accompanied by excessive exhaust smoke, the amount of fuel delivered to the cylinders must be reduced to suit the conditions under which the engine is required to operate, by de-rating the fuel pump delivery at a value of 3% per 330 metres (1,000 feet) of altitude operation.

It is recommended that vehicles intended for operation in high altitudes should have the injection pump adjusted by a C.A.V. dealer.

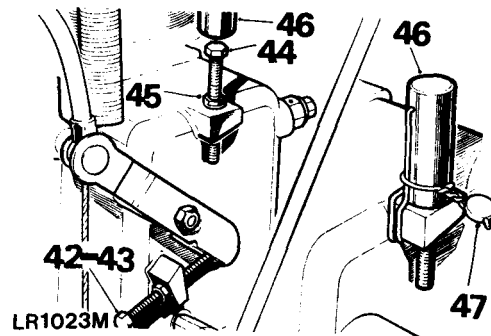

DATA

Injection timing setting	13° BTDC
Idling speed	590 ± 20 rev/min
Maximum speed setting (sealed)	4,200 ± 20 rev/min

FUEL LIFT PUMP, 2¼ litre models

Remove and refit

19.45.09

Removing

- 1 Remove bonnet panel. 76.16.01
 - 2 Remove the air cleaner. 19.10.04.
 - 3 Disconnect fuel pipes at fuel pump.
- NOTE:** The pump illustrated is for 2¼ litre Petrol models. The Diesel engine pump is similar except that no filter bowl is required.
- 4 Remove the fixings and withdraw the pump and side cover complete.
 - 5 Remove the fuel pump from the side cover.

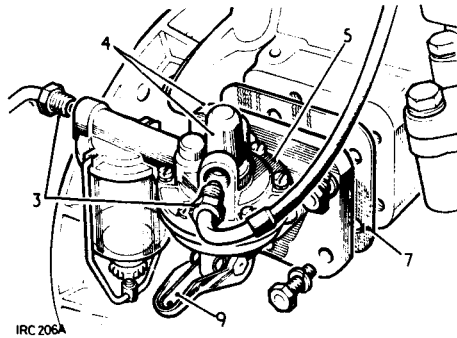

IRC 206A

Refitting

- 6 Refit pump to cover.
- 7 Smear general purpose grease on both sides of the joint washer.
- 8 Refit the fuel pump and joint washer and connect the fuel pipes.
- 9 Prime the fuel pump by operating the hand prime lever until no resistance is felt.
- 10 Diesel models. Release the air vent screws on the fuel distributor casing (19.50.01 refers) and operate the pump hand prime lever until the fuel flow from the vent screws is free of air. Close the vent screws.
- 11 Reverse instructions 1 and 2.

FUEL LIFT PUMP, 2.6 litre models

Remove and refit

19.45.09

Removing

- 1 Disconnect the battery leads.
- 2 Lift the seat (RH side) and remove the seat box panel to expose the fuel pump.
- 3 Disconnect the wiring at the snap connector.
- 4 Disconnect the fuel outlet pipe.
- 5 Disconnect the fuel inlet pipes.
- 6 Remove the clamp fixings.

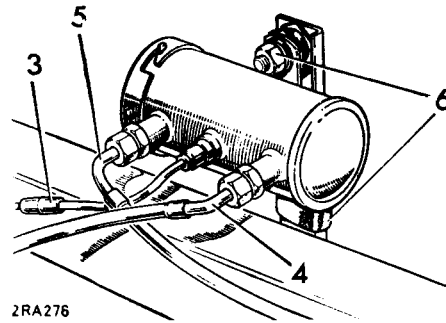

2RA276

- 7 Withdraw the pump and mounting rubbers.

Refitting

- 8 Reverse instructions 1 to 7.

FUEL LIFT PUMP, 2¼ litre models

Overhaul

19.45.16

Dismantling

- 1 Remove the lift pump. 19.45.09
- 2 2¼ litre Petrol. Unscrew the nut at base of sediment bowl, move the retainer aside, and withdraw the bowl, sealing washer and filter gauze. Care should be taken to avoid damage to filter gauze.
- 3 Mark the upper and lower halves of pump casing to ensure correct alignment on reassembly.
- 4 Remove top cover fixing screws, and while pressing diaphragm tab against pump body, lift top cover clear.

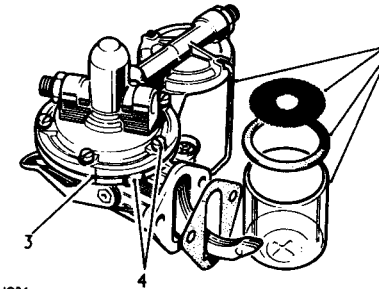

IRC 1024

- 5 If required, remove the valves retaining staking using a scraper, warm the top cover and withdraw the valves.

NOTE: Note the valves fitted position before removing.

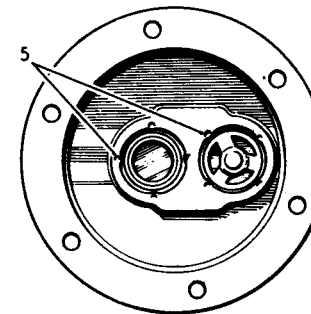

IRC 1026

- 6 Ease the diaphragm from pump body, slightly depress metal part of diaphragm and turn through 90° in either direction, whereon the diaphragm spring will push diaphragm clear.
- 7 File the peening marks from the oil seal housing and lever out oil seal and retainer.

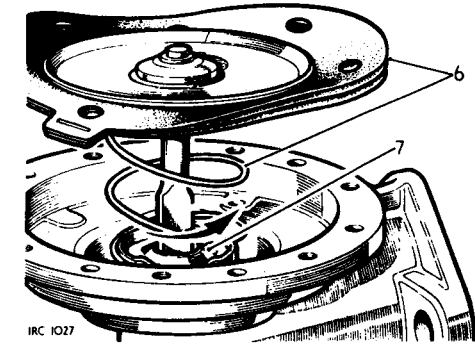

IRC 1027

- 8 Using a small chisel, remove the staking from the rocker arm retainers.
- 9 Withdraw the retainers.
- 10 Withdraw the rocker arm.
- 11 Withdraw the rocker arm pin and washers.
- 12 Detach the operating link.
- 13 Withdraw the rocker arm spring.

continued

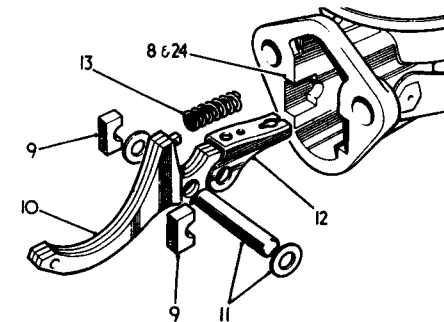

IRC 1028

- 14 It is extremely unlikely that the hand priming mechanism will ever require replacement, but may be removed by filing the hexagon each side of the operating lever and springing the hand lever clear, withdraw the cork washers and hand rocker.

Inspecting

- 15 Clean all parts thoroughly in paraffin.
 16 Examine all parts for wear and replace as necessary.
 17 Replace all gaskets.
 18 Sediment bowl filter disc must be free of damage and fit tightly around inlet neck of upper casing. (2¼ Petrol models).
 19 Renew diaphragm assembly if any sign of hardening, cracking or porosity is present.
 20 Only very slight wear should be tolerated at the rocker arm contact face, pivot pin, operating link and diaphragm pull rod slots.
 21 Springs should be replaced, ensure correct type are used.
 22 Test valves for air tightness, by suction.
 23 Check upper and lower casing flanges for distortion, using a straight edge.

Reassembling

- 24 Reverse 7 to 13. Re-stake to secure the rocker lever retainers and the oil seal retainer.

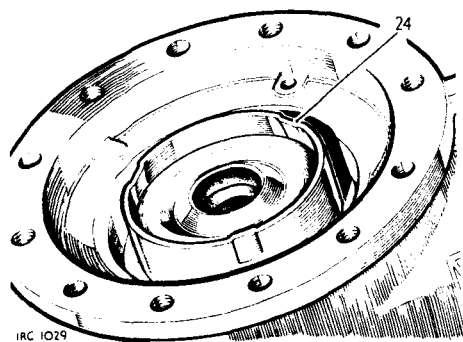

IRC 1029

- 25 To refit the diaphragm assembly, hold the pump body with the diaphragm return spring in position, and the rocker arm held outwards. Position the diaphragm over the spring with the flattened end of the pull rod in line with the slot in the operating link. Push the diaphragm inwards and turn to lock.
 26 Fit the valve gaskets into the top cover.
 27 Fit the inlet and outlet valves and secure by staking.
 28 Place top cover assembly in position, aligning the marks made before dismantling. Fit securing screws, but do not tighten at this stage; using hand priming lever, fully depress diaphragm and fully tighten securing screws.

NOTE: The diaphragm outer edges should be approximately flush with the outer edge of the pump joint faces when fitted, any appreciable protrusion of the diaphragm beyond the joint face edges indicates improper fitment and necessitates the release of the securing screws and refitment in accordance with item 28.

- 29 2¼ litre Petrol. Replace filter gauze and neoprene sealing ring, refit retaining clip and position sediment bowl centrally and secure the retaining clip.

NOTE: Do not overtighten securing nut, to prevent cracking of sediment bowl.

Fuel pump test: without special equipment

- 30 Immerse pump in a bath of paraffin and operate rocker arm several times to flush.
 31 Hold the pump clear of the bath and continue to operate the rocker arm until the pump is empty, then place a finger over the inlet port and operate rocker arm several times. A distinct suction should be heard when the finger is removed from the inlet port, denoting that a reasonable degree of suction has been developed.

- 32 Place a finger over the outlet port and again operate the rocker arm. Air pressure should be felt for two to three seconds after rocker movement has ceased. Build up the air pressure in the pump again, and with the finger held firmly over the outlet, submerge the pump completely in the paraffin bath, then observe the joint face edges for signs of air leakage.
 33 Fit the lift pump. 19.45.09.

FUEL LIFT PUMP 2.6 litre models

Overhaul 19.45.16

- 1 Remove the pump. 19.45.09.
- 2 Release the end cap and withdraw the gasket and filter.
- 3 Renew the gasket and filter if necessary.
- 4 Reverse instructions 1 and 2

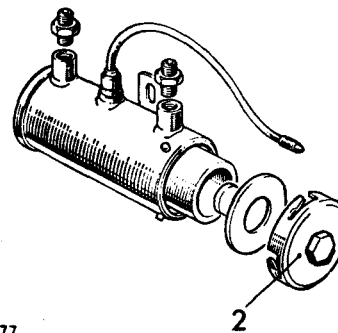

2RA277

FUEL SYSTEM, 2¼ litre Diesel models

Priming 19.50.01

Procedure after dismantling filter/sedimentor, items 1 to 6.
Procedure after emptying fuel system, items 7 to 12.
Procedure after emptying distributor pump, item 13.

Procedure after fuel filter/sedimentor dismantling

NOTE: When models fitted with a sedimentor have had the water drained only from the sedimentor bowl, no priming is necessary as the water is replaced by fuel automatically syphoned from the tank. However, if the sedimentor has been dismantled or air has entered the body, or where the fuel filter element has been replaced or the filter bowl cleaned, then the system must be primed as follows:

- 1 Do not attempt to start the engine hoping to draw the fuel through in this way, otherwise the full priming procedure will be necessary.
- 2 Slacken the bleed pipe banjo bolt on the top of the main fuel filter.
- 3 Operate the hand priming lever on the mechanical pump, until fuel free from bubbles emerges.

NOTE: Always ensure that fuel pump lever is on the bottom of the operating cam when priming the fuel system, otherwise maximum moment of the priming lever will not be obtained.

- 4 Tighten the bleed pipe banjo bolt with fuel still emerging.

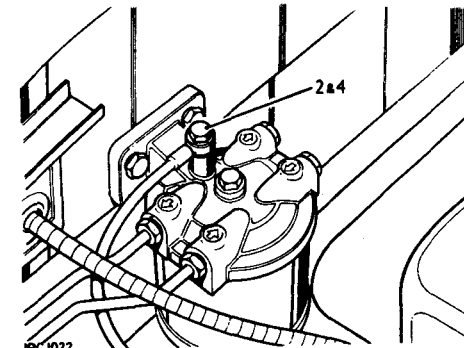

IRC 1022

- 5 Operate the hand priming lever once or twice to clear the last bubbles of air into the filter bleed pipe.
- 6 Start engine in normal way and check for leaks.

Procedure when fuel system has been emptied

- 7 Carry out operations above, 1 to 5 inclusive.
- 8 Release air vent screw on distributor body.

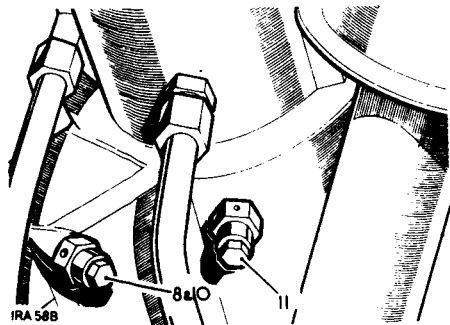

- 9 Operate the fuel pump hand priming lever until fuel free of air emerges.
- 10 Retighten the air vent screw.
- 11 To ensure that all air is exhausted from the pump it may also be necessary to slacken air vent screw in the distributor control cover and repeat items 9 and 10.
- 12 Start the engine in the normal way and check for leaks.

Procedure when distributor pump only has been drained

- 13 Carry out instructions 8 to 12 inclusive.

FUEL TANK DRAINING

WARNING: Petrol (gasoline) must not be extracted or drained from a vehicle standing over a pit.

Petroleum or gasoline vapour is highly flammable, and in confined spaces is also very explosive and toxic.

When petrol/gasoline evaporates it produces 150 times its own volume in vapour, which when diluted with air becomes an ignitable mixture. The vapour is heavier than air, and will always fall to the lowest level and it can readily be distributed throughout a workshop by air currents. Even a small spillage of petrol or gasoline is potentially very dangerous.

Extracting or draining petrol (gasoline) from a vehicle fuel tank, must be carried out in a well ventilated area, preferably outside the workshop. All forms of ignition must be extinguished or removed, any hand lamps must be flameproof and kept clear of any spillage. The receptacle used to contain the petrol drained or extracted must be more than adequate to receive the full amount to be drained.

FUEL TANK, side mounted (as applicable)

Remove and refit 19.55.01

Removing

- 1 Disconnect the battery earth lead.
- 2 Drain fuel into a clean container.
- 3 Remove RH seat cushion and fold seat squab forward.
- 4 Disconnect hoses, tank to filler tube and breather hose.
- 5 Remove cover panel for fuel tank.
- 6 Disconnect wires at gauge unit.
- 7 Disconnect fuel supply pipe and for Diesel models spill return pipes.
- 8 Support tank and remove tank securing bolts.
- 9 Lower tank and remove from under the vehicle.

Refitting

- 10 Reverse instructions 1 to 9.
- 11 If the vehicle is a Diesel model, prime the fuel system. 19.50.01.

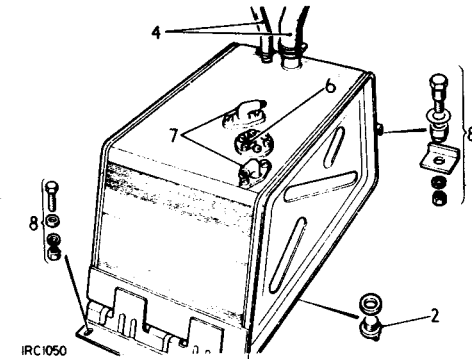

FUEL TANK, rear mounted (as applicable)

Remove and refit 19.55.01

Removing

- 1 Disconnect the battery.
- 2 Drain the fuel into a clean container.
- 3 Release the clip securing the filler tube hose to the tank.
- 4 Support the tank and remove the tank securing bolts, then lower the tank sufficient only to give access to the pipes and leads at the tank top.
- 5 Disconnect the breather and air balance pipes.
- 6 Disconnect wires at gauge unit.
- 7 Disconnect the fuel supply pipe, and for Diesel models, the spill return pipe.
- 8 Lower the tank and remove from under the vehicle.

Refitting

- 9 Reverse instructions 1 to 8.
- 10 If the vehicle is a Diesel model, prime the fuel system. 19.50.01.

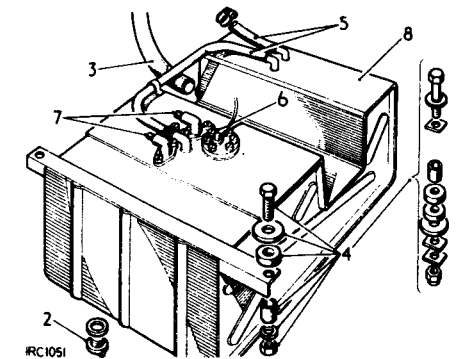

FUEL INJECTORS

Remove and refit

19.60.01

Removing

- 1 Remove the bonnet panel. 76.16.01.
- 2 Remove the air cleaner. 19.10.04.
- 3 Slacken the injector feed pipes at the distributor pump.
- 4 Disconnect the injector feed pipes at the injectors.
- 5 Disconnect the fuel spill pipes at No. 4 injector.
- 6 Slacken the spill rail fixings at the injectors.
- 7 Remove the injector fixings.
- 8 Withdraw the injectors complete with spill rail.
- 9 Take care to avoid damage to the needle valves which protrude from the injector faces. Immerse the components in clean fuel pending overhaul or refitting.
- 10 Remove the steel sealing washers from the injector housing bores.
- 11 The remaining sealing washers (copper) are normally withdrawn with the injectors, ensure that they are not left behind in the bores.

Refitting

- 12 Refit the new steel sealing washers into the injector bores, with the raised corrugation uppermost.
- 13 Reverse 7 and 8, using new copper sealing washers. Injector fixings torque 0,8 to 1,0 kgf. m (6 to 8 lbf. ft.). Tighten alternate fixings by equal amounts to ensure injector is seated squarely.
- 14 Reverse 3 to 6.
- 15 Prime the fuel system. 19.50.01.
- 16 Reverse instructions 1 and 2.

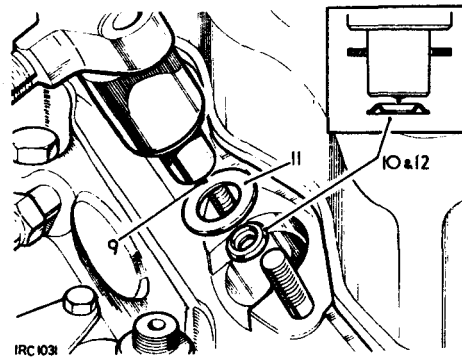
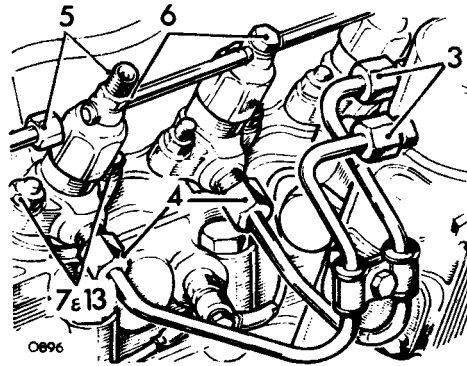

FUEL INJECTORS

Spray, check on vehicle

19.60.02

General

Injector nozzle type

'Pintaux' nozzles are used, these being a development of the 'Pintle' type nozzle. In a 'Pintle' nozzle, the valve stem provides a pin or pintle which protrudes through the nozzle body orifice to form the correct fuel spray angle.

In a 'Pintaux' nozzle, an auxiliary spray hole is also provided for easy starting. The 'Pintaux' type nozzle has been developed by CAV for use with the type of cylinder head chosen for Rover CI engines. This type of nozzle has been found most satisfactory for starting and general running and must be replaced by the same type only.

Checking nozzle assemblies

WARNING: Do not allow the fuel spray to contact the person otherwise injury may result from skin penetration.

When an injection nozzle is considered to be the cause of irregular running and loss of power, a quick check may be made by loosening the fuel feed pipe union nut on each nozzle in turn, whilst the engine is idling and again at approximately 1,000 rev/min.

If the injection nozzle assembly being checked has been operating properly, there will be a distinct reduction in engine speed accompanied by obvious roughness, but a faulty injection nozzle may make little or no difference to the engine note when its fuel feed pipe is loosened.

Checking spray

- 1 Remove the fuel spill gallery pipe complete from the injection nozzles.
- 2 Disconnect the fuel feed pipe (injection pump to nozzle) from the nozzle to be tested and from the injection pump.
- 3 Release the fixings and withdraw the suspected injection nozzle assembly;

reconnect the pipe and nozzle assembly to the injection pump in a position whereby fuel ejection may be observed.

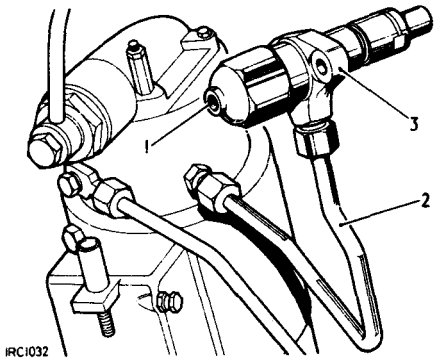

- 4 Loosen the union nuts securing the remaining fuel pipes to injection nozzles.
- 5 Whilst the starter turns the engine over, observe the manner in which fuel issues from the nozzle and compare the spray form with the correct form as illustrated. Very little fuel should issue from the main spray hole with the engine turning over at starter speed but a fine spray comparable to that illustrated should be ejected from the auxiliary spray hole.
- 6 If the ejected fuel is more in the form of a liquid jet or issues from the main pintle hole, then the nozzle and holder assembly should be removed for overhaul and a replacement unit fitted.
- 7 Reverse instructions 1 to 4.

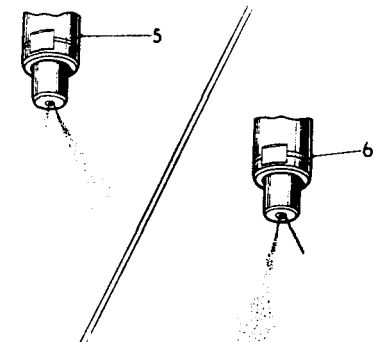

FUEL INJECTORS

Overhaul 19.60.08

Dismantling and assembling, items 1 to 26.
Bench testing procedure, items 27 to 41.

Service tools:

- 271482 Spanner for nozzle cap
- 271483 Injector nozzle testing and setting kit
- 278181 Tool for flushing injector nozzles
- 278182 Adaptor for Pintaux injector
- 605002 Injector nozzle cleaning kit
- 605003 Injector nozzle cleaning wire (0,2 mm diameter)

NOTE: Where a number of tools are supplied in kit form, the manufacturer's identification number is quoted in the text referring to the specific tool. The individual tools which make up a kit are not available separately.

Dismantling

- 1 Remove the injectors. 19.60.01.
- 2 Disconnect the injectors from the fuel spill rail.
- 3 Remove the combined locknut and end cap.
- 4 Withdraw the sealing washer.

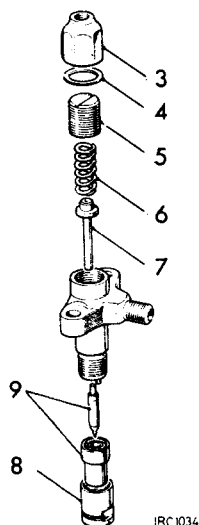

- 5 Unscrew the pressure adjusting screw.
- 6 Withdraw the pressure spring.
- 7 Withdraw the valve spindle.
- 8 Unscrew the cap nut.
- 9 Withdraw the nozzle valve and body.

Cleaning and inspecting

- 10 Soak the component parts of the assembly in Shell Calibration Fluid to loosen carbon deposits, but do not allow parts of any one assembly to be interchanged with those of another.
- 11 Brush away all external carbon deposits from component parts with a brass wire brush ET068 (or 7044/68) and replace them in the oil bath. Particular care must be exercised when cleaning the pintle and seat of nozzle valve to avoid scratching or scoring, which may result in spray distortion.
- 12 Clean the three oil feed passages in the nozzle body with a wire or drill of 1,5 mm (0.062 in.) diameter.
- 13 Remove the carbon from the annular recess with tool ET071 (or 7044/71).
- 14 Remove the carbon from the valve seat, using tool ET070 (or 7044/70) with a rotary motion.
- 15 Select the appropriate size probe from the pocket of cleaning kit and secure it in the pintle hole cleaner ET069 (or 7044/69). Insert the probe into the bore of nozzle valve body and allow the end to extend through the main fuel outlet, then turn in a rotary manner to remove carbon.
- 16 Carbon may be removed from the nozzle valve cone by inserting the valve into tool ET072 (or 7044/72) and then rotating it alternately in a clockwise then anti-clockwise manner whilst pressing the valve inward. If the nozzle is blued or the seating has a dull circumferential ring indicating pitting or wear, the nozzle body and valve should be returned to a CAV Service Agent and replacement parts fitted. Do not attempt to lap the nozzle valve to body. This process requires special equipment and training.

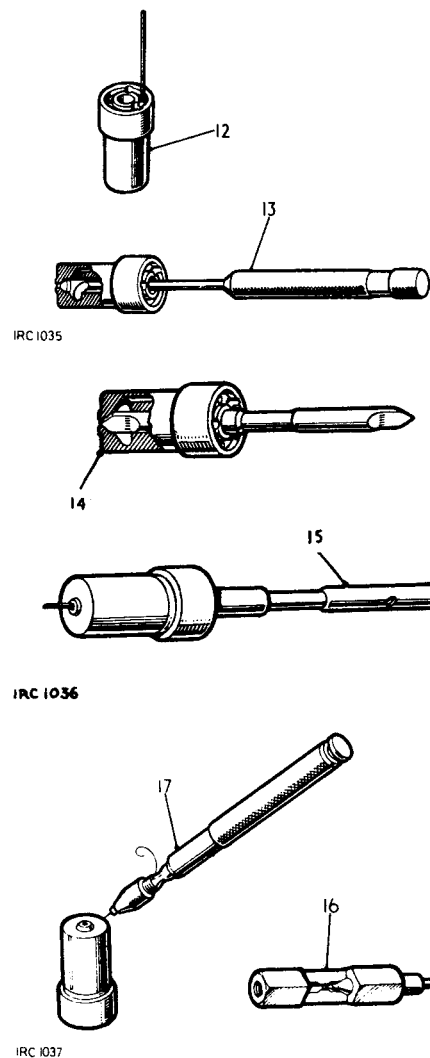

- 17 Clean the auxiliary spray hole using tool ET120 (or 7044/120) fitted with probing wire 0,20 mm (0.008 in.) diameter. Wire 605003.

NOTE: Allow 1,5 mm (0.062 in.) only to extend from the chuck and thus minimise the possibility of the wire bending or breaking while probing. Great care must be taken to prevent breakage of the wire in the hole.

- 18 With flushing tool ET427 (or 278181) secured to the nozzle testing outfit, fit the nozzle body (spray holes uppermost) to the flushing tool and pump test oil through vigorously. This flushing process is necessary for the removal of any tiny carbon particles which may have become lodged in the body after scraping and probing.
- 19 Examine the pressure faces of nozzle body and nozzle holder to ascertain their freedom from scoring and scratches. These surfaces must be perfectly smooth.

continued

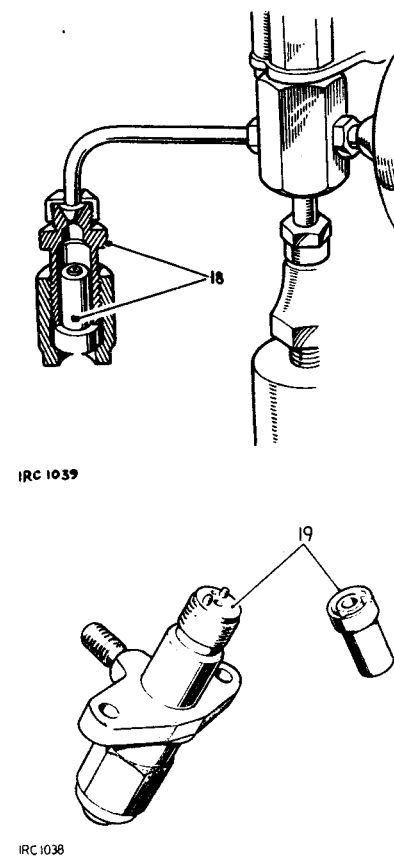

Reassembling

- 20 Fit the nozzle valve to nozzle and check for freedom of movement.
- 21 Immerse the nozzle body and valve in the fluid bath and assemble whilst submerged.
- 22 Wash the remaining components thoroughly and reverse dismantling procedure, items 1 to 8.
- 23 Set the injection nozzle assembly in accordance with the following test procedure.

Bench testing of injection nozzle and holder assembly**General information, items 24 to 26**

- 24 To check a nozzle assembly and ensure that it is functioning correctly, a setting outfit (as illustrated in 'Procedure') is essential. A bench covered with linoleum or non-ferrous sheet metal is most suitable for mounting the outfit; such a surface facilitates the cleanliness essential when checking nozzle parts. Between the bench and setting outfit, a tray, also of non-ferrous metal, should be positioned to prevent spilt fuel spreading. Small containers may be attached to the bench to isolate the component parts of each assembly; these parts are carefully mated by the manufacturers and must not be interchanged. Lastly, a small bath with cover, containing Shell Calibration Fluid for washing components, should be kept conveniently near.
- 25 The efficient operation of the injection nozzle assembly is dependent on four main conditions, as follows:
 - a The nozzle valve must open at 135 Ats.
 - b The rate of back leakage must be within 150 to 100 Ats.
 - c Seat tightness must be sufficient to prevent leakage.
 - d Spray form must compare favourably with the illustrations.

- 26 Pressure setting, back leakage and seat tightness tests may be made by coupling the injection nozzle and holder assembly direct to the pressure feed pipe on setting outfit, but an adaptor must be fitted between the pipe and injection nozzle and holder assembly when testing spray form. This adaptor, see item 38, increases the pressure of fuel to the injection nozzle and holder assembly sufficiently for the main and auxiliary spray form to be determined.

Testing procedure

WARNING: The injection nozzle must not be allowed to point towards the operator when spraying and the hands must never be allowed to contact the spray which has great penetrating force.

- 27 Remove the cap from oil container and fill with 0,8 litre (1.5 pints) of Shell Calibration Fluid.
- 28 Air vent the system by removing the vent screw, allow oil to flow freely for a few seconds and replace the screw whilst the flow continues.
- 29 Operate the pump handle until oil flows from pipe.

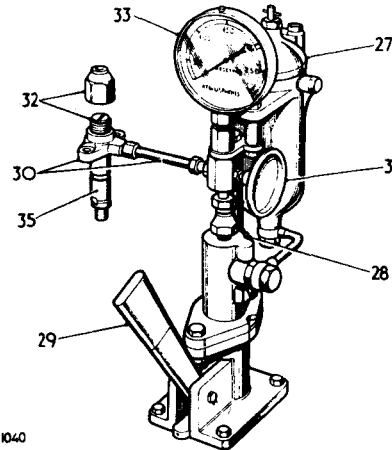

IRC1040

- 30 Connect the injector and holder assembly to the pressure feed pipe with the nozzle pointing downwards. The length and bore of this pipe is important and replacement pipes must be approximately 75 mm (2.8 in.) between the union nuts and of 3 mm (0.118 in.) bore.
- 31 Close the check valve to keep the pressure gauge out of circuit and smartly operate the hand lever several times to expel all air from the system.

Back leakage test

- 32 Adjustment is made by removing the combined end cap and locknut from the nozzle holder, and turning the adjusting screw clockwise to increase and anti-clockwise to decrease the opening pressure.
- 33 Fit assembled injector to nozzle setting outfit and adjust to open at 160 to 170 atmospheres then pump up to just below this figure, release handle to allow the needle of gauge to fall naturally. Time the pressure drop from 150 atmospheres down to 100 atmospheres.
- 34 This should be not less than 5 seconds for the original nozzle and not less than 7 seconds if a new one is to be fitted, and not more than 36 seconds for either with oil temperature 10° to 21° C (50° to 70° F).
- 35 Check externally the top and bottom of nozzle cap nut and pressure pipe union nuts for signs of oil leakage. If leakage occurs at the nozzle cap nut, remove the nut and examine the pressure faces of nozzle holders and nozzle body (see item 19) for presence of foreign matter or surface scoring, before tightening further.
A leakproof nozzle assembly with an excessive rate of pressure drop indicates a worn nozzle valve; the nozzle valve and nozzle body should be renewed.

Pressure setting

- 36 The selected operational opening pressure of the nozzle valve is 135 atmospheres. Readjust to this setting in the manner described in item 32.

Seat tightness

- 37 Wipe the bottom face of the injection nozzle dry and raise the pressure in the system to 125 atmospheres. A slight dampness on the bottom face is permissible, but blob formation or dripping indicates a badly seating valve in which case the assembly should be dismantled for further examination.

Spray form

- 38 Fuel delivery to the injection nozzle assembly when testing spray form must be characteristically similar to fuel delivery under normal operating conditions and to effect these conditions an adaptor (CAV Y7044872) must be fitted between the injection nozzle assembly and the pressure pipe.
- 39 The adaptor differs mainly in the cap nut and nozzle valve from the ordinary type of injection nozzle and holder assembly as fitted to the engine; the nozzle valve has no pintle.
- 40 The cap nut is extended, bored and threaded to receive nozzles for testing.

- 41 Connect the adaptor assembly to the pressure pipe.
- 42 Remove the end cap and adjust the opening pressure of the nozzle valve to 220 atmospheres.
- 43 Screw the injection nozzle and holder assembly to be tested, into the adaptor.
- 44 With the check valve closed, operate the handle smartly to expel air from the system. The auxiliary spray form may be tested at 60 strokes per minute and the main spray at 140. Spray development from starting to running speeds is illustrated, this illustration should be referred to and compared with the spray form of nozzles under test.
- 45 When satisfactory, reverse instructions 1 to 3.

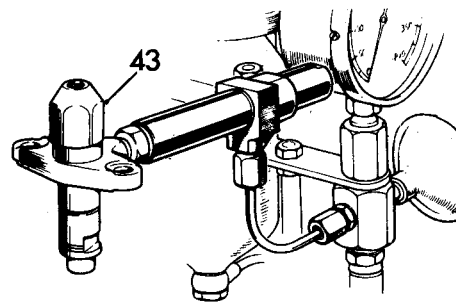
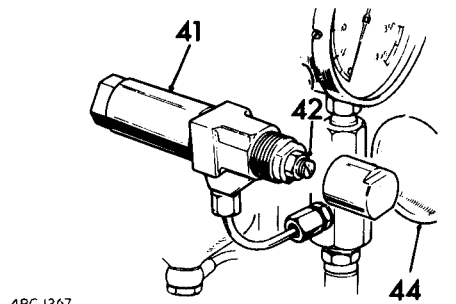

Injector nozzle spray form, starting to running conditions.

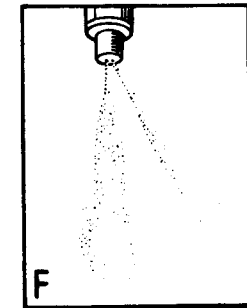
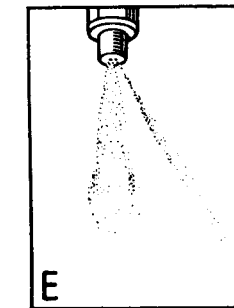
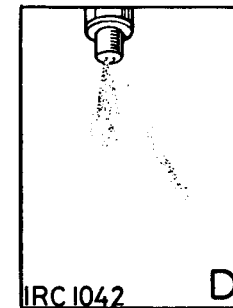
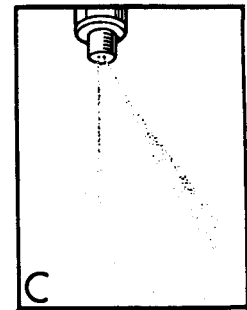
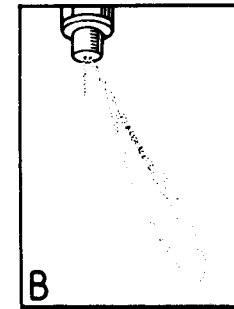
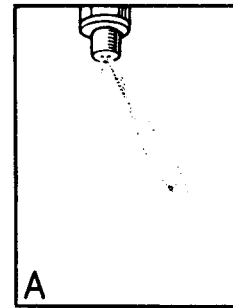

COOLANT

Drain and refill

26.10.01

Draining

- 1 Remove the radiator filler cap.
- 2 Remove the radiator drain plug situated on the right hand side.
- 3 Open the cylinder block drain tap located as follows:
2½ litre — at left hand side adjacent to the dipstick. (Plug on later engines).
2.6 litre — at right hand side adjacent to the engine breather.

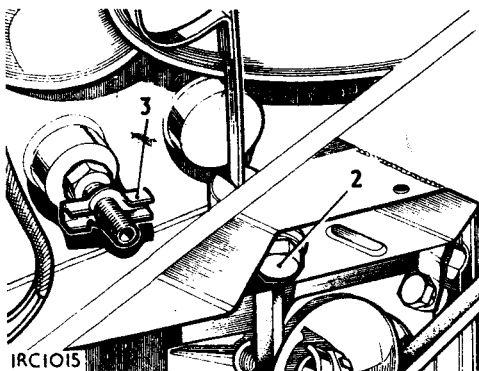

Refilling

- 4 Reverse 2 and 3. If antifreeze solution is to be added, first pour 4.5 litres (8 pints) of water into the system then add the required quantity of the recommended solution (see Section 09).
- 5 Top up with water to between 12 mm and 19 mm (0.5 in. and 0.75 in.) below the bottom of the radiator filler neck.
- 6 Check and top up after the initial short engine run.
- 7 Ensure that the expansion tank coolant is maintained at approximately one-quarter full.

EXPANSION TANK

Remove and refit

26.15.01

Removing

- 1 Open and prop the bonnet.
- 2 Disconnect the radiator overflow hose at the expansion tank.
- 3 Slacken the pinch bolt on the securing bracket.
- 4 Withdraw the expansion tank.

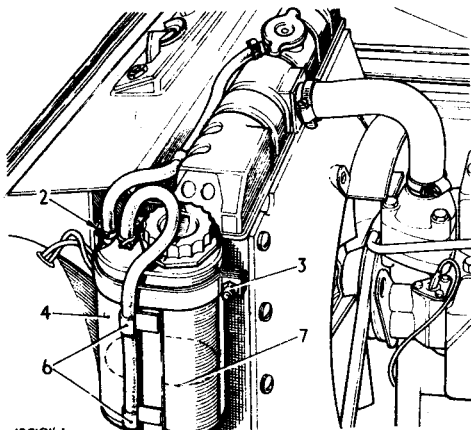

Refitting

- 5 Reverse 3 and 4.
- 6 Refit the vent hose into the clips on the tank retainer.
- 7 Fill the expansion tank approximately one-quarter full with coolant.
- 8 Reconnect the overflow hose.
- 9 Close the bonnet.

FAN BLADES AND PULLEY — 2½ LITRE MODELS

Remove and refit

26.25.01

Removing

- 1 Open and prop the bonnet.
- 2 Remove the shroud from the radiator fan cowl.
- 3 Remove the cowl fixings and hold the cowl against the engine.
- 4 Slacken the alternator fixings
- 5 Remove the fan belt.
- 6 Remove the fan blade fixings.
- 7 Withdraw the fan blades and pulley.

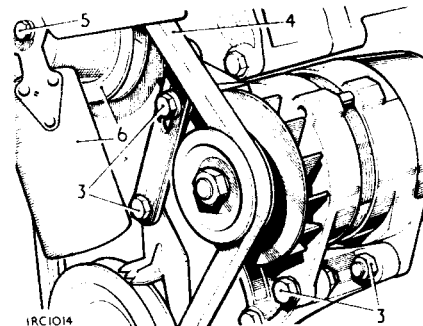
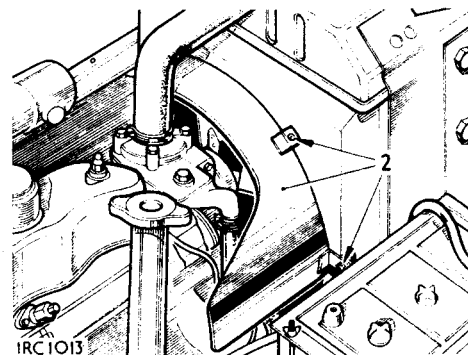

Refitting

- 8 Reverse 2 to 7. Adjust the fan belt tension to 6.3 mm to 9.5 mm (0.25 in. to 0.375 in.) checked by thumb pressure between the fan and crankshaft pulleys.
- 9 Refit the fan shroud.
- 10 Close the bonnet.

FAN BLADES AND PULLEY — 2.6 LITRE MODELS

Remove and refit

26.25.01

Removing

- 1 Open and prop the bonnet.
- 2 Where a steel bladed fan is fitted:- remove the shroud from the radiator fan cowl.
- 3 Slacken the alternator fixings.
- 4 Remove the fan belt.
- 5 Remove the fan blade fixings.

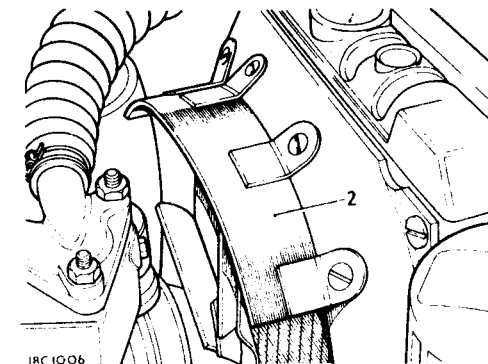

- 6 Withdraw the fan blades, packing piece and pulley.

Refitting

- 7 Reverse 3 to 6. Adjust the fan belt tension to 8 mm to 11 mm (0.312 in. to 0.437 in.) checked by thumb pressure between the fan and crankshaft pulleys.

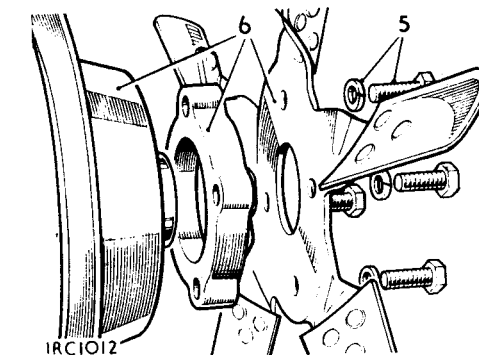

- 8 Refit the fan shroud.
- 9 Close the bonnet.

Where a viscous fan with plastic blades is fitted:-

- 1 Remove the radiator — 26.40.04.
- 2 Remove the four fixings to remove the plastic fan.
- 3 If necessary, remove the central nut and washer to extract the viscous coupling from the water pump/pulley.

Refitting

- 4 Reverse 1 to 3.

RADIATOR AND FRONT PANEL ASSEMBLY

Remove and refit

26.40.01

Removing

- 1 Remove the bonnet.
- 2 Disconnect and remove the battery.
- 3 Drain the radiator and cylinder block.
- 4 Remove five self-tapping screws and remove the radiator grille.
- 5 Remove four screws and the front valance.
- 6 Working from the wheel arch, remove the five nuts and bolts securing the front panel to the right-hand front wing. This will include the two nuts and bolts retaining the bonnet prop bracket.
- 7 Slacken the third nut and bolt retaining the bonnet prop bracket to facilitate alignment of holes when refitting.
- 8 Remove the five nuts securing the front panel to the left-hand wing and remove the studs.
- 9 Release the top hose from the radiator connection.
- 10 Remove the nut securing the fan cowl to the battery tray.

NOTE: Before carrying out instructions 11 and 12 make a note of the colour codes to facilitate re-connection.

- 11 Release the headlamp and auxiliary harness from the 'P' clips from the centre of the front panel and disconnect the earth lead secured by the centre bolt.
- 12 Disconnect the auxiliary harness from the left-hand side and withdraw the harness from the right-hand side.
- 13 Disconnect the right-hand headlamp harness from the left-hand section at the centre of the radiator aperture and withdraw the cables through the grommets.
- 14 Remove the three nuts and bolts securing the front panel to the cross-member. To ensure correct alignment of the front panel on reassembly make a note of the number and position of the rubber packing pieces.

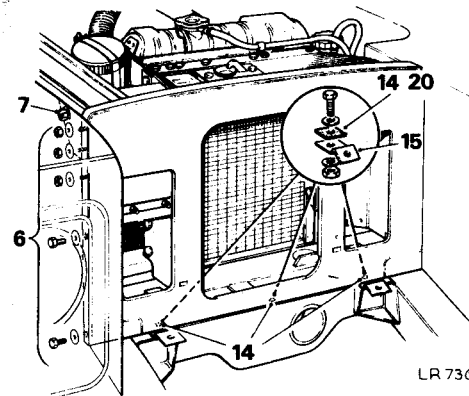

- 15 Retrieve the two brackets for securing the front valance.
- 16 Pull the front panel and radiator assembly forward to enable the radiator bottom hose to be released from the water pump connection.
- 17 Withdraw the front panel and radiator assembly complete.
- 18 Fit and tighten the radiator drain plug (if fitted) or close the drain top.

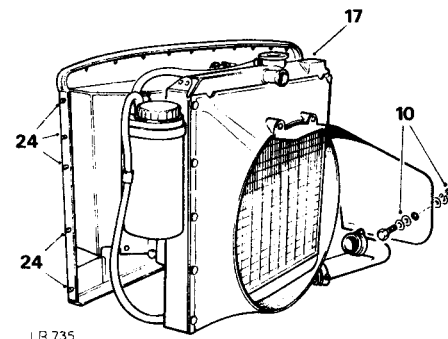

Refitting

- 19 Lift the front panel and radiator into position and connect the bottom hose to the water pump.

- 20 Refit the rubber packing pieces in the same positions as originally fitted to ensure correct alignment of the radiator.
- 21 Fit the three nuts and bolts securing the front panel to the chassis cross-member and attach the two brackets for retaining the front valance to the two end bolts.
- 22 Secure the front panel to the right-hand wing and tighten the third nut and bolt retaining the bonnet stay bracket.
- 23 Fit the five nuts and bolts.
- 24 Fit the two strips of captive studs to the left-hand side of the front panel and secure with the five nuts and washers.
- 25 Pass the left-hand and right-hand headlamp leads through the grommets and fasten together with the bullet connectors.
- 26 Pass the right-hand harness through the grommets and connect to the leads on the left-hand side with bullet fasteners.
- 27 Secure the harness with the 'P' clips and connect the earth wire to the centre bolt in the top of the front panel.
- 28 Connect the top hose to the radiator.
- 29 Secure the fan cowl to the battery tray.
- 30 Fit the front valance.
- 31 Fill the cooling system in accordance with instructions in operation 26.10.01.
- 32 Fit the bonnet.

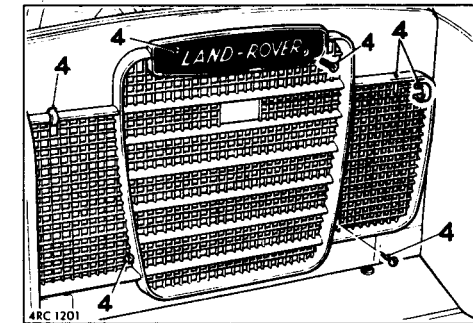

- 5 Remove the radiator grille.
- 6 Remove the radiator cap.
- 7 Remove the radiator drain plug.
- 8 Open the drain tap at the cylinder

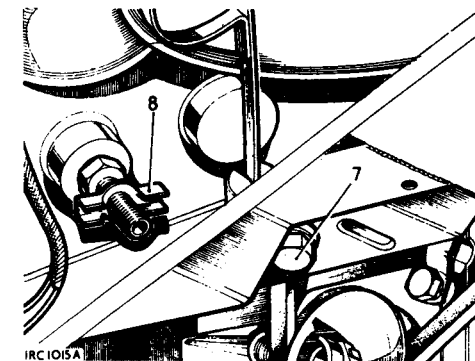

RADIATOR

Remove and refit

26.40.04

Removing

- 1 Open and support the bonnet.
- 2 Disconnect the battery earth lead.
- 3 2.6 models – remove the air cleaner – 19.10.01.
- 4 Remove the four screws and two anti-rattle clips securing the radiator grille.

block right hand side (2.6 litre) or left hand side (2¼ litre) models.

- 9 Disconnect the radiator top and bottom hoses.
- 10 Remove the fan cowl and shroud from the radiator and displace rearwards clear of the radiator.

- 11 Remove the expansion tank.
- 12 Remove the fixings, radiator to grille panel.
- 13 Carefully lift out the radiator avoiding the fan blades and shroud.

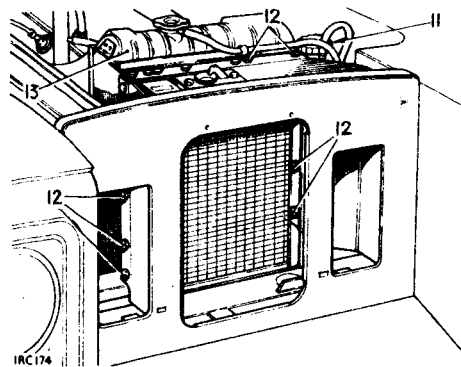

- 14 Where required, lift out the fan cowl.

Refitting

- 15 Reverse 1 to 14.
- 16 Run the engine and check all hose connections for leakages.

THERMOSTAT – 2¼ LITRE MODELS

Remove and refit 26.45.01

Removing

- 1 Remove the radiator cap and partially drain the coolant.
- 2 Remove the outlet pipe and thermostat housing fixings.
- 3 Withdraw the pipe and housing complete.

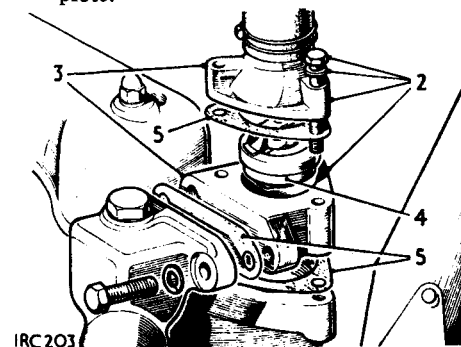

IRC203

- 4 Separate the pipe from the housing and withdraw the thermostat and 'O' ring seal.
- 5 Withdraw and discard the joint washers.

Refitting

- 6 Smear both sides of the new joint washers with a small quantity of general purpose grease.
- 7 Ensure that the thermostat bleed hole is clear to prevent air locks when refilling.
- 8 Reverse 1 to 5.

THERMOSTAT – 2.6 LITRE MODELS

Remove and refit 26.45.01

Removing

- 1 Drain off coolant at the engine sufficient to drain the thermostat housing.
- 2 Remove the fixings and lift aside the outlet pipe.
- 3 Withdraw the joint washer.
- 4 Withdraw the thermostat.

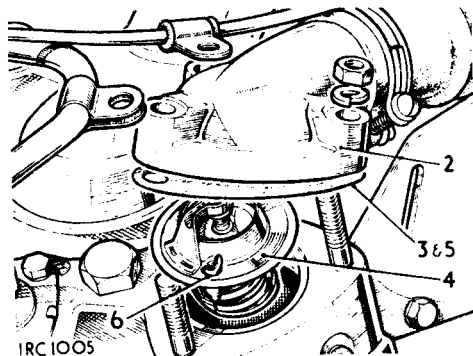

IRC1005

Refitting

- 5 Smear both sides of the new joint washer with a small quantity of general purpose grease.
- 6 Ensure that the thermostat bleed hole is clear to prevent air locks when refilling.
- 7 Reverse 1 to 4.

THERMOSTAT

Test 26.45.09

Testing

- 1 Remove the thermostat. 26.45.01.
- 2 Immerse the thermostat in water in a suitable container.
- 3 Heat the water and note the temperature at which the thermostat commences to open; this should be within the range as follows:
2¼ litre engines – 70.5°C to 75.5°C.
2.6 litre engines – 75°C to 80°C.
- 4 The thermostat is not adjustable or serviceable; repair is by replacement.
- 5 Reverse 1.

- 8 Disconnect the radiator bottom hose at the water pump.
- 9 Disconnect the by-pass hose.
- 10 Remove the water pump.
- 11 Withdraw the joint washer.

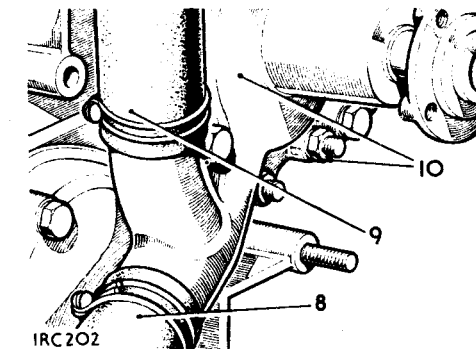

IRC202

Refitting

- 12 Smear both sides of a new joint washer with general purpose grease.
- 13 Reverse 4 to 11. Adjust the fan belt to give 6.3 to 9.5 mm (0.25 to 0.375 in.) free movement when checked midway between the fan and crankshaft pulleys.
- 14 Reverse 1 to 3.

WATER PUMP – 2¼ LITRE MODELS

Remove and refit 26.50.01

Removing

- 1 Remove the bonnet. 76.16.01.
- 2 Drain the cooling system. 26.10.01.
- 3 Remove the shroud from the radiator fan cowl.
- 4 Slacken the alternator fixings and remove the fan belt.
- 5 Remove the alternator adjusting link.
- 6 Remove the fan blades.
- 7 Withdraw the fan pulley.

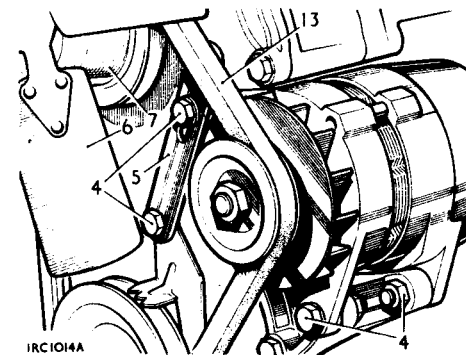

IRC1014A

WATER PUMP – 2.6 LITRE MODELS

Remove and refit 26.50.01

Removing

- 1 Remove the bonnet. 76.16.01.
- 2 Drain the cooling system. 26.10.01.
- 3 Where a viscous fan with plastic fan blades is fitted, remove the radiator, 26.40.04., before removing the fan belt, fan blades and pulley/viscous coupling. 26.25.01.
- 4 Disconnect the radiator bottom hose from the water pump.

continued

- 5 Where a heater is fitted, remove the water valve. 80.10.16.
- 6 Remove the water pump fixings; note the fitted positions of the varying length bolts.

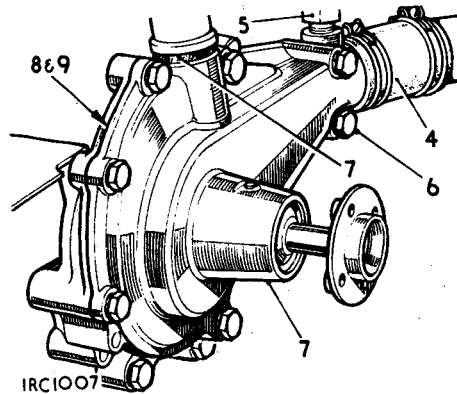

- 7 Withdraw the water pump, tilting upwards to clear the locating dowels and compress the 'O' ring seal on the by-pass outlet.
- 8 Withdraw the joint washer from the adaptor joint face.

Refitting

- 9 Smear both sides of the new joint washer with a minimum of general purpose grease.
- 10 Position the joint washer onto the pump adaptor face.
- 11 Lubricate a new 'O' ring seal with Silicone Compound MS4 and position the seal on the pump by-pass outlet.

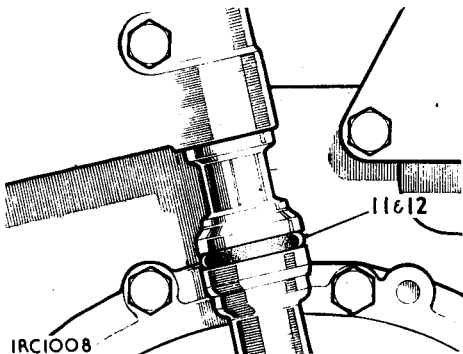

- 12 Reverse 7. Ensure that the 'O' ring does not become dislodged.
- 13 Reverse 1 to 6.

WATER PUMP

Overhaul

26.50.06

Dismantling

- 1 Remove the water pump. 26.50.01.
- 2 Remove the bearing location bolt.
- 3 Drift out the impeller, bearing and spindle as an assembly from the pump body and hub.
- 4 Cut through and remove the seal assembly from the spindle.
- 5 Insert the spindle into the water pump body, so that the impeller is in the position of the fan pulley.
- 6 Drift the spindle and bearing assembly from the impeller.

Inspecting

- 7 Examine the spindle and bearing assembly; it need not be renewed if the bearing is satisfactory and the spindle is free from excessive corrosion.
Clean any corroded portion of the spindle and paint with a suitable chlorinated rubber primer or, alternatively, with a good quality aluminium paint or other anti-corrosive paint.
The impeller must be a press fit on the spindle. If the impeller is loose on the spindle, replace either part as necessary.

Re-assembling

- 8 Where a steel deflector washer is fitted to the pump spindle, check that there is a minimum clearance of 0.45 mm (0.018 in.) between the washer and the bearing housing face.

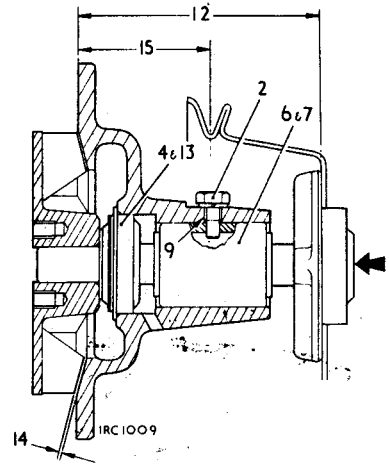
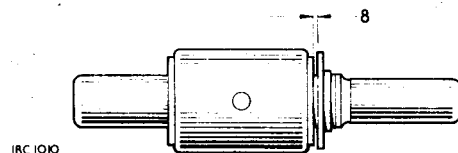

- 9 Insert a few drops of thick oil in the location hole in the bearing.
- 10 Suitably mark the spindle bearing housing and the pump body so that the bearing locating screw holes may be easily aligned during assembly.
- 11 Fit the spindle and bearing to the pump body and fit the locating screw.

- 12 Press the fan pulley hub on to the spindle to a set dimension measured between the front face of the pulley hub and the mounting face of the water pump body as follows:
2½ litre models – 89,48 mm ± 0,25 mm (3.523 in. ± 0.010 in.).
2.6 litre models – 97,00 mm ± 0,25 mm (3.819 in. ± 0.010 in.).
When pressing on the hub, support the spindle to avoid load falling on the bearing location bolt.
- 13 Fit the carbon ring and seal assembly to the pump body with the carbon ring outwards.
- 14 Press the impeller onto the spindle until there is 0,50 mm to 0,63 mm (0.020 in. to 0.025 in.) clearance between the impeller vanes and the pump body. Check using feeler gauges.
- 15 Offer the fan pulley to the assembly and check the fan belt groove position relative to the pump mounting face which must be as follows:-
2½ litre models – 49,4 mm ± 0,25 mm (1.945 in. ± 0.010 in.).
2.6 litre models – 46,2 mm ± 0,25 mm (1.819 in. ± 0.010 in.).
- 16 Reverse 1.

DATA

Dimension from front face of hub to rear (mounting) face of water pump

2½ litre models	89,48 mm ± 0,25 mm (3.523 in. ± 0.010 in.)
2.6 litre models	97,00 mm ± 0,25 mm (3.819 in. ± 0.010 in.)

Clearance between impeller vanes and pump body

0,50 mm to 0,63 mm (0.020 in. to 0.025 in.)

Dimension from fan belt groove in pulley to rear (mounting) face of water pump

2½ litre models	49,4 mm ± 0,25 mm (1.945 in. ± 0.010 in.)
2.6 litre models	46,2 mm ± 0,25 mm (1.819 in. ± 0.010 in.)

EXHAUST SYSTEM – 2.6 LITRE MODELS

NOTE: Different Market requirements necessitate the fitting of various exhaust systems to the 88" and 109" vehicles. These systems are detailed in the illustrations which are designed to make any exhaust system operation self-explanatory. The written text regarding the exhaust systems apply to the basic vehicles.

Remove and refit

Front pipe, items 1 to 6	30.10.09
Intermediate pipe, items 7 to 9	30.10.11
Silencer, items 10, 11 and 13	30.10.14
Tail pipe, items 10 to 13	30.10.19

Front exhaust pipe

Removing

- 1 Remove the securing bolts at the front exhaust pipe and intermediate pipe joint.
- 2 Remove the securing bolts fixing the front exhaust pipe to the flexible mounting.
- 3 Remove nuts and spring washers securing pipe at exhaust manifold.
- 4 Withdraw the exhaust pipe.
- 5 If required, remove the bolts securing the heat shield to the front exhaust pipe and withdraw the two halves of the shield

Refitting

- 6 Reverse 1 to 5, leaving the flexible mounting loose until the pipe has been firmly secured to the manifold and intermediate pipe.

Intermediate exhaust pipe

Removing

- 7 Remove securing bolts at front exhaust pipe and silencer.
- 8 Remove the securing bolts fixing the intermediate pipe to the flexible mounting and withdraw the intermediate pipe.

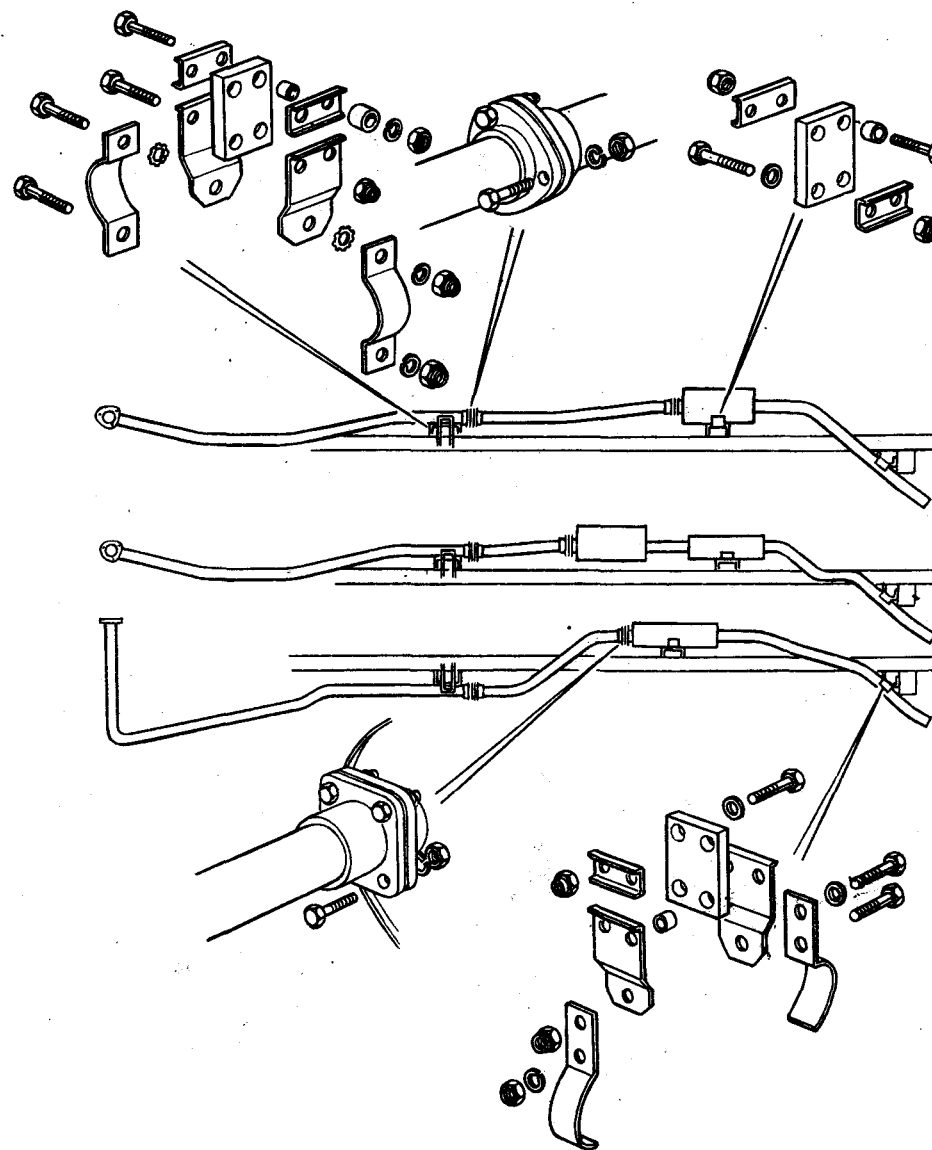

Refitting

- 9 Reverse 7 and 8, leaving the flexible mounting loose until the pipe has been firmly secured to front exhaust pipe and silencer.

Exhaust silencer and tail pipe

Removing

- 10 Remove the bolts securing the intermediate pipe to the silencer and the bolts securing the tail pipe to the flexible mounting, keeping the silencer supported by hand.
- 11 Withdraw the silencer assembly.
- 12 If required, remove the bolts securing the tail pipe to the silencer and withdraw the tail pipe.

Refitting

- 13 Reverse 10 to 12, ensuring that the bolts securing intermediate pipe to silencer are fully tightened before finally clamping the tail pipe support.

EXHAUST SYSTEM – 2¼ LITRE MODELS

NOTE: Different Market requirements necessitate the fitting of various exhaust systems to the 88" and 109" vehicles. These systems are detailed in the illustrations which are designed to make any exhaust system operation self-explanatory. The written text regarding the exhaust systems apply to the basic vehicles.

Remove and refit

Front pipe	30.10.09
Intermediate pipe	30.10.11
Silencer and tail pipe	30.10.22

Front exhaust pipe

Removing

- 1 Remove securing bolts at front exhaust pipe and intermediate pipe joint.
- 2 Remove nuts and spring washers securing pipe at exhaust manifold.
- 3 Withdraw the exhaust pipe and joint washer.

Refitting

- 4 Reverse 1 to 3.

Intermediate exhaust pipe

Removing

- 5 Remove securing bolts at front exhaust pipe and silencer.
- 6 Remove supporting clamp and withdraw intermediate exhaust pipe.

Refitting

- 7 Reverse 5 and 6, leaving the supporting clamps loose until the pipe has been secured firmly to front exhaust pipe and silencer.

Exhaust silencer (Right hand steering models only)

Removing

- 8 Remove the bolts securing intermediate pipe to silencer and release support saddle from silencer tail pipe, keeping silencer supported by hand.
- 9 Withdraw silencer assembly.

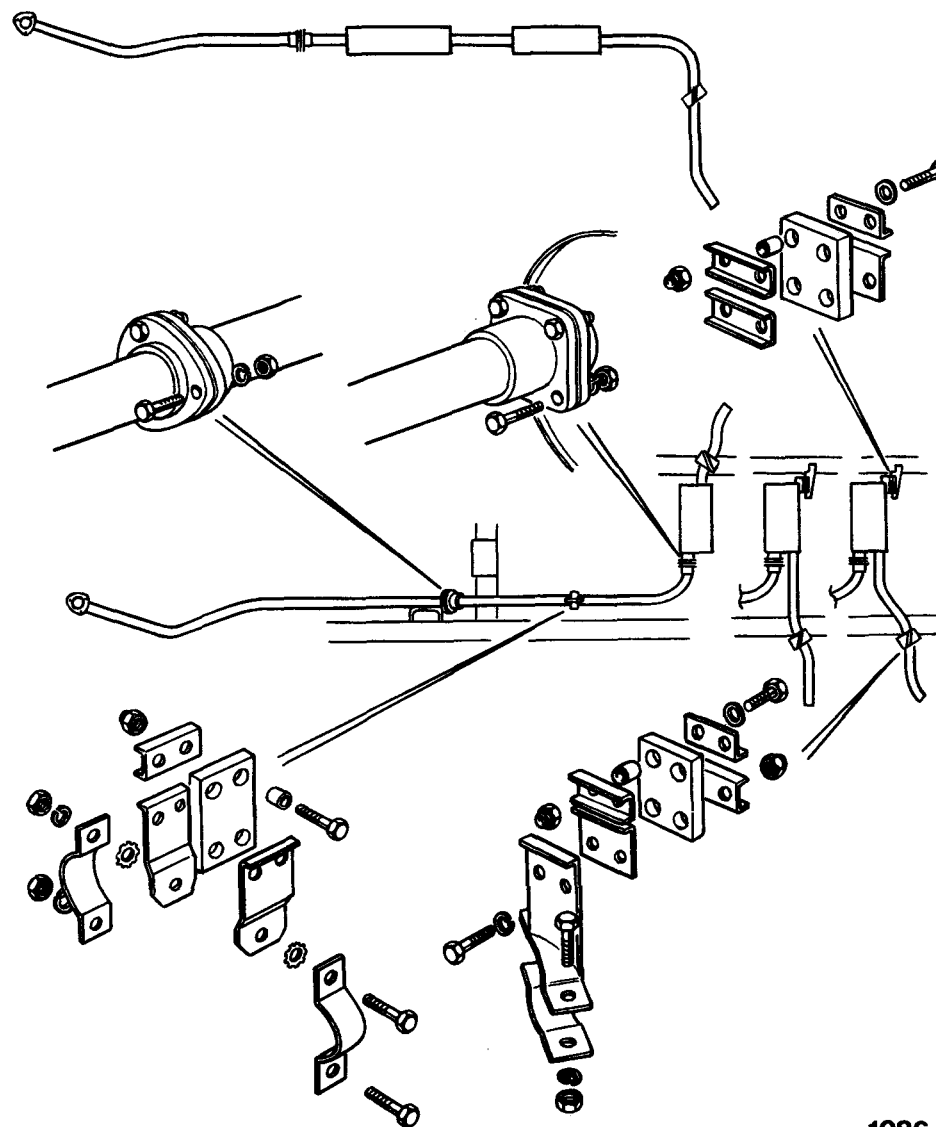

Refitting

- 10 Reverse 8 and 9, ensuring that the bolts securing intermediate pipe to silencer are fully tightened before finally clamping the tail pipe support.

Exhaust silencer (Left hand steering models)

Removing

- 11 Remove bolts securing intermediate pipe to silencer.
- 12 Keeping the silencer supported, release the supporting strap for silencer right hand side and saddle clamp on tail pipe, then withdraw silencer assembly.

Refitting

- 13 Fit the silencer in position and loosely support by means of supporting strap and saddle clamp.
- 14 Secure the intermediate pipe to silencer.
- 15 Finally tighten bolts securing support strap and saddle clamp.

INDUCTION AND EXHAUST MANIFOLD ASSEMBLY – 2¼ LITRE PETROL MODELS

Remove and refit 30.15.01

Removing

- 1 Remove the bonnet. 76.16.01.
- 2 Remove the carburetter. 19.15.09.
- 3 Remove the exhaust heat shield.
- 4 Disconnect the front exhaust pipe from the manifold.
- 5 Remove the induction and exhaust manifold assembly.

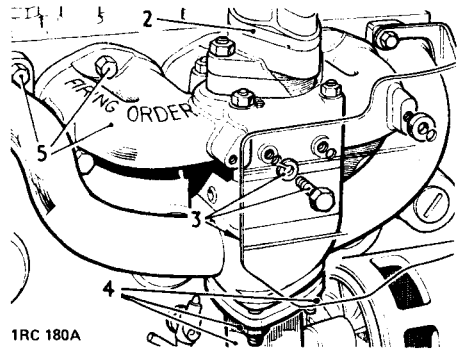

- 6 Withdraw the joint washers for the induction manifold.
- 7 Separate the induction manifold from the exhaust manifold.
- 8 Withdraw the joint washer.

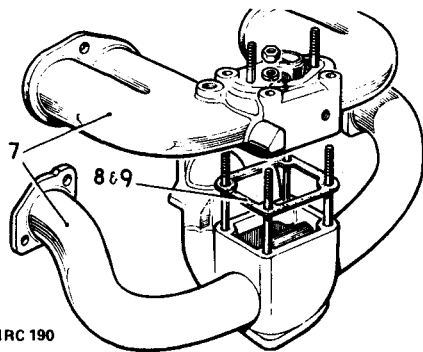

Refitting

- 9 Using a new joint washer, assemble the induction manifold to the exhaust manifold.
- 10 Tighten the fixings, induction manifold to exhaust manifold, to a torque of 2,3 kgf. m (17 lbf. ft.), then slacken off slightly.
- 11 Fit the joint washers for the induction manifold with the raised rings towards the cylinder head.

NOTE: Joint washers are not fitted to the exhaust manifold.

- 12 Coat the mating faces of the cylinder head and exhaust manifold with Rocol Anti-seize Compound Foliac J166 (paste).
- 13 Fit the induction and exhaust manifold assembly. Tighten the exhaust manifold bolts to 1,3 kgf m (10 lbf ft) and engage the lock plates.
- 14 Fit the induction and exhaust manifold assembly. Torque 2,3 kgf m (17 lbf ft).
- 15 Tighten the fixings, induction manifold to exhaust manifold. Torque 2,3 kgf m (17 lbf ft).
- 16 Reverse 1 to 4.

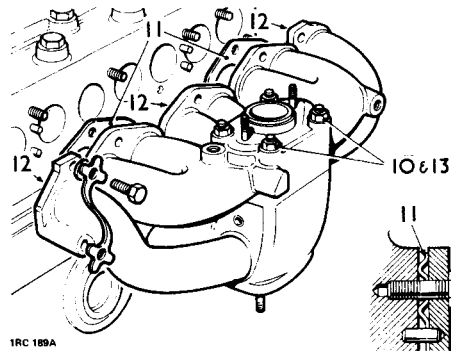

INDUCTION AND EXHAUST MANIFOLD – 2¼ LITRE DIESEL MODELS

Remove and refit 30.15.01

Removing

- 1 Remove the bonnet panel. 76.16.01.
- 2 Disconnect the air cleaner hose.
- 3 Disconnect the engine breather hose.
- 4 Disconnect the front exhaust pipe at the manifold.
- 5 Withdraw the oil level dipstick.
- 6 Where a brake servo is fitted, disconnect the manifold throttle control rod and the vacuum supply hose.

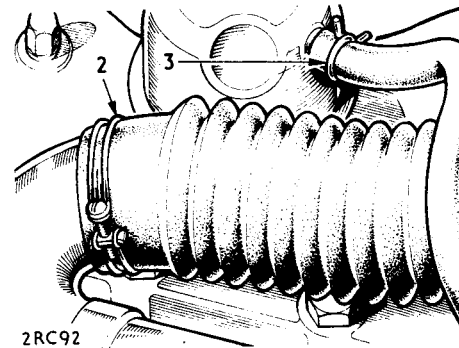

- 7 Remove the four upper and five lower fixings and withdraw the manifolds.
- 8 Withdraw the manifolds joint washer.

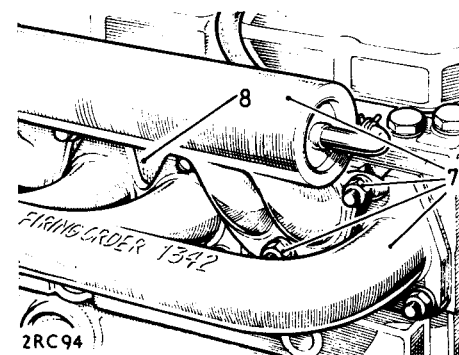

Refitting

- 9 Reverse 7 and 8; do not tighten any fixings until all are in place.
- 10 Where applicable, reverse 6. Ensure that the manifold throttle valve opens slightly in advance of the distributor/injection pump linkage. Adjust at the cross-shaft linkage as necessary.
- 11 Reverse 1 to 5.

EXHAUST MANIFOLD – 2.6 LITRE MODELS

Remove and refit 30.15.10

Removing

- 1 Disconnect the front exhaust pipe from the manifold.
- 2 Remove the fixings and withdraw the exhaust heat shield.
- 3 Remove the manifold fixings.

continued

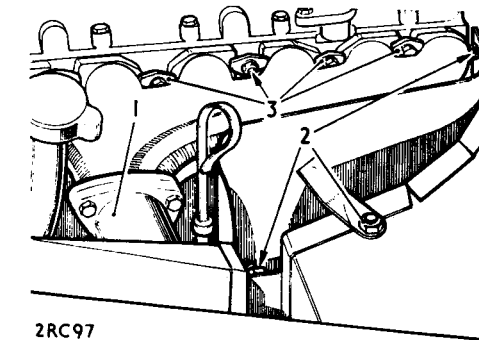

- 4 Withdraw the manifold.
- 5 Withdraw the joint washers.

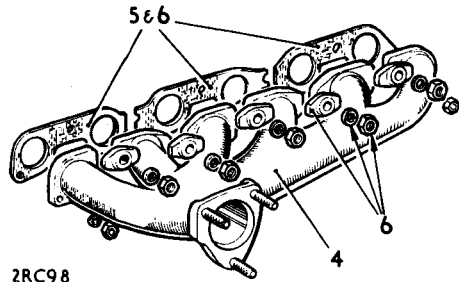

2RC98

Refitting

- 6 Reverse 3 to 5 with the joint washers plain faces toward the engine. Tighten the fixings evenly to avoid distortion.
- 7 Reverse 1 and 2.

CLUTCH ASSEMBLY

Remove and refit 33.10.01

Service tool: 605022 Clutch plate alignment gauge

NOTE: If it is required to remove the clutch only, it is not necessary to remove the seat base nor completely remove the gearbox. Proceed with the gearbox removal 37.20.01, but only withdraw the gearbox rearward approximately 130 mm (5 in.), to give access to the clutch fixings.

Removing

- 1 Remove the front floor. 76.10.12.
- 2 Remove the front seat base. 76.70.06.
- 3 Remove the gearbox assembly. 37.20.01.
- 4 Mark the clutch cover fitted position relative to the flywheel.
- 5 Do not disturb the three bolts located in the apertures in the clutch cover.
- 6 Remove the clutch assembly.
- 7 Withdraw the clutch driven plate.

Refitting

- 8 Smear the splines of the primary pinion, the clutch centre and the withdrawal unit abutment faces with Molybdenum disulphide grease such as Rocol MTS 1000.
- 9 Reverse 6 and 7 locating the driven plate with the side marked 'Flywheel side' towards the flywheel, and ensure that the clutch cover and flywheel assembly marks are aligned. Centralising tool 605022.
- 10 secure the cover fixings evenly, using diagonal selection. Torque 3,0 to 3,5 kgf m (22 to 25 lbf ft).
- 11 Reverse 1 to 3.

DATA

Clutch driven plate diameter 241,3 mm (9.5 in.)
 Damper springs colour identification

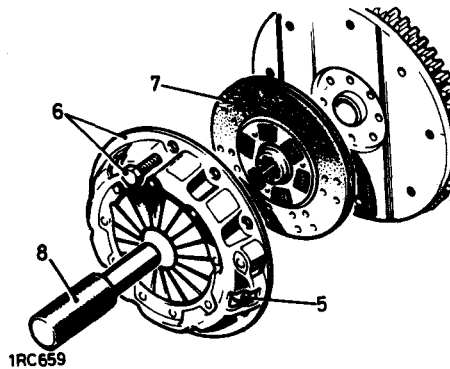

CLUTCH ASSEMBLY

Overhaul 33.10.08

Clutch assembly

The clutch assembly is of the diaphragm spring type and no overhaul procedures are applicable. Repair is by replacement only.

Clutch driven plate

Examine clutch driven plate for wear and signs of oil contamination. Examine all rivets for pulling and distortion, rivets must be below the friction surface. If oil contamination is present on the friction linings or if they are appreciably worn, replace the clutch driven plate assembly complete or alternatively, replace the friction linings following standard workshop practices.

241,3 mm (9.5 in.)
 Dark green.

HYDRAULIC SYSTEM

Bleed 33.15.01

Procedure

NOTE: During the procedure, keep the fluid reservoir topped up to avoid introducing further air into the system. Use only the recommended type of hydraulic fluid. Division 09 refers.

- 1 Attach a length of suitable tubing to the slave cylinder bleed screw.
- 2 Place the free end of the tube in a glass jar containing clutch fluid.
- 3 Slacken the bleed screw.
- 4 Pump the clutch pedal, pausing at the end of each stroke, until the fluid issuing from the tubing is free of air with the tube free end below the surface of the fluid in the container.
- 5 Hold the tube free end immersed and tighten the bleed screw when commencing a pedal down stroke.

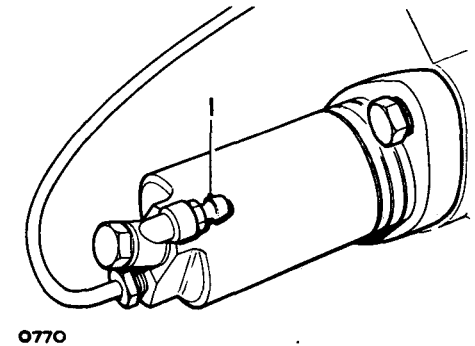

MASTER CYLINDER

Remove and refit 33.20.01

Removing

- 1 Remove the bonnet. 76.16.01.
- Left hand steering models 2-12.
- 2 Remove the left hand side front wing rear top section retaining bolt.
 - 3 Remove the two nuts/bolts securing the lower wing edge to the sill panel.
 - 4 Remove the four nuts/bolts securing the splash plate to the bulkhead.
 - 5 Remove the three bolts securing the splash plate to the wing.
 - 6 Remove the splash plate.
 - 7 Remove the four bolts securing the rear vertical wing edge to the 'A' post section.
 - 8 Disconnect the hydraulic pipe from the clutch master cylinder plug aperture to prevent leakage.
 - 9 Remove the brake pipe clip from the clutch pedal cover and disconnect the return spring.
 - 10 Remove the six bolts securing the clutch pedal box.

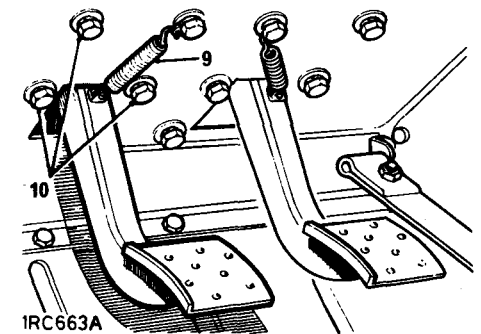

continued

- 11 Ease away the rear section of the wing panel.
- 12 Manoeuvre out the clutch pedal box assembly.

Right hand steering models.

- 13 Disconnect the fluid pipe from the master cylinder.

All models

- 14 Remove the top cover and gasket from the clutch pedal bracket.
- 15 Remove the fixings from the end of the master cylinder push rod.
- 16 Detach the master cylinder from the pedal bracket.
- 17 Drain the fluid from the cylinder.

Refitting

- 18 Secure the cylinder to the pedal bracket, adjust the push rod lever to give 1,55 mm (0.062 in.) free play between the push rod and the piston, 6 mm (0.25 in.) at the pedal. Tighten the locknuts. See clutch pedal and master cylinder setting. 33.20.02.
- 19 Fit the gasket to the top cover.

Right hand steering models

- 20 Connect the fluid pipe to the master cylinder.

Left hand steering models

- 21 Refit the clutch master cylinder assembly to the vehicle. Ensure that the pedal return spring is connected.
- 22 Connect the hydraulic pipe.
- 23 Secure the brake pipe clip.

All models

- 24 Bleed the clutch system. 33.15.01.
- 25 Check the pedal free play, 6 mm (0.25 in.). Check the pedal lever height from the floor, 140 mm (5.50 in.).
- 26 Reverse 1 to 7.

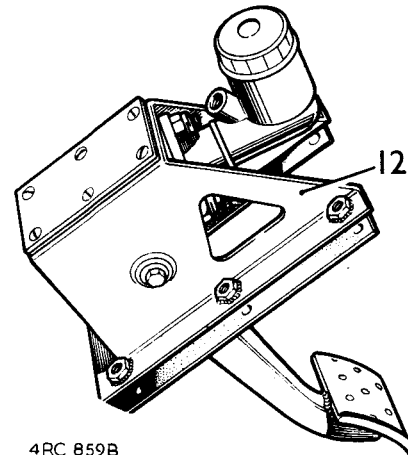

4RC 859B

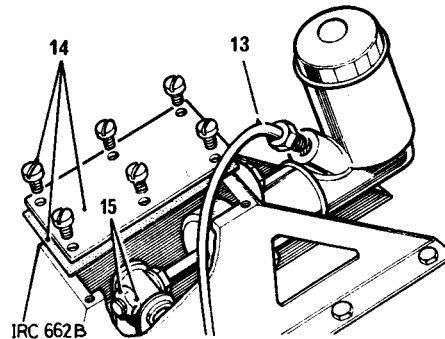

IRC 662B

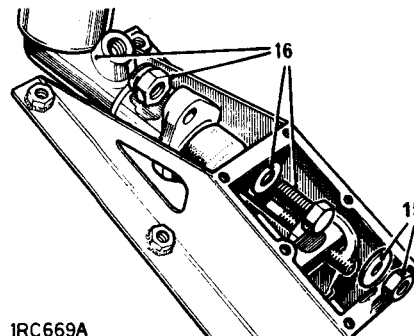

IRC 669A

MASTER CYLINDER

Overhaul

33.20.07

Dismantling

- 1 Remove the master cylinder. 33.20.01.
- 2 Remove the circlip.
- 3 Withdraw the push rod and retaining washer.
- 4 Withdraw the piston assembly. If necessary, apply a low air pressure to the outlet port to expel the piston.

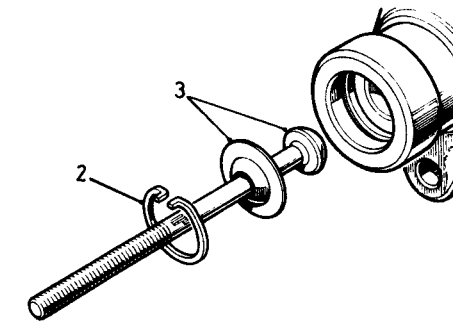

IRC 671

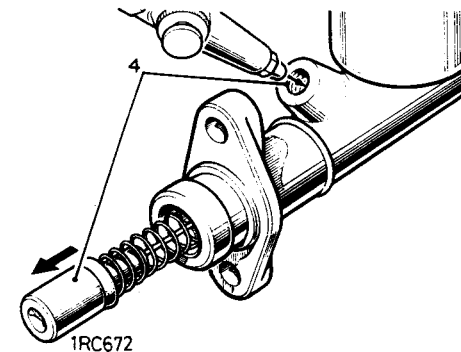

IRC 672

- 5 Prise the locking prong of the spring retainer clear of the piston shoulder and withdraw the piston.
- 6 Withdraw the piston seal.
- 7 Compress the spring and position the valve stem to align with the larger hole in the spring retainer.

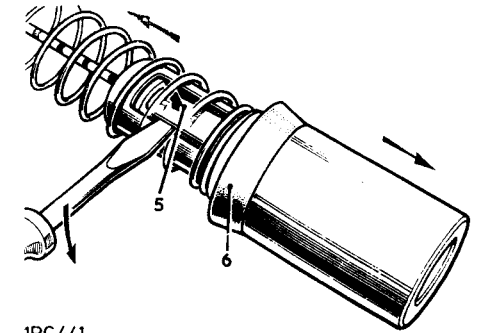

IRC 441

- 8 Withdraw the spring and retainer.
- 9 Withdraw the valve spacer and spring washer from the valve stem.
- 10 Remove the valve seal.

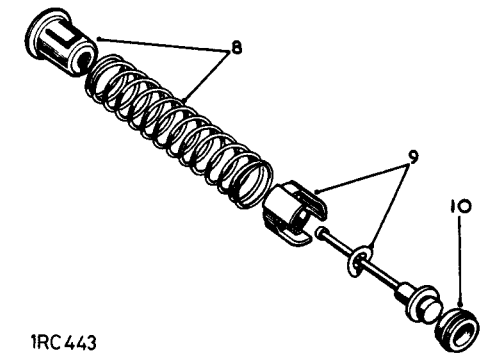

IRC 443

Inspecting

- 11 Clean all components in Girling cleaning fluid and allow to dry.
- 12 Examine the cylinder bore and piston, ensure that they are smooth to the touch with no corrosion, score marks or ridges. If there is any doubt, fit new replacements.
- 13 The seals should be replaced with new components.

Assembling

- 14 Smear the seals with Castrol-Girling rubber grease and the remaining internal items with Castrol-Girling Brake and Clutch Fluid.

- 15 Fit the valve seal, flat side first, on to the end of the valve stem.
- 16 Place the spring washer, domed side first, over the small end of the valve stem.
- 17 Fit the spacer, legs first.

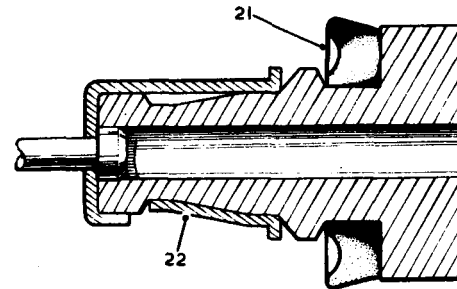
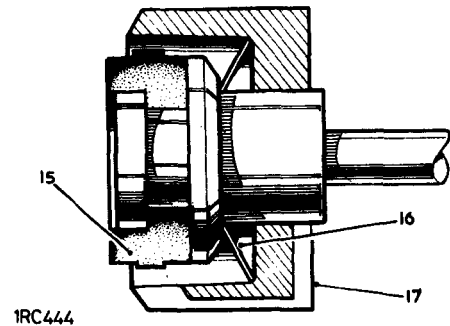

1RC445

- 23 Smear the piston with Castrol-Girling rubber grease and insert the assembly, valve end first, into the cylinder.
- 24 Fit the push rod, retaining washer and circlip.
- 25 Refit the master cylinder. 33.20.01.

- 18 Place the coil spring over the valve stem.
- 19 Insert the retainer into the spring.
- 20 Compress the spring and engage the valve stem in the keyhole slot in the retainer.

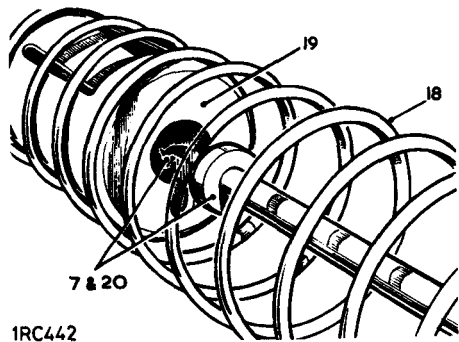

1RC442

- 21 Fit the seal, large diameter last, to the piston.
- 22 Insert the piston into the spring retainer and engage the locking prong.

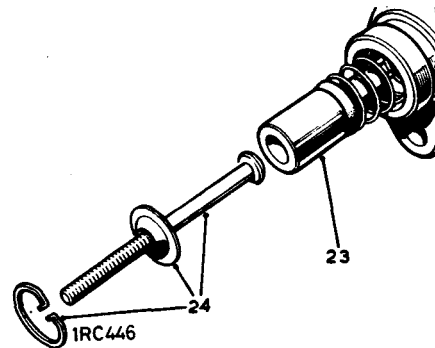

CLUTCH RELEASE ASSEMBLY

Remove and refit 33.25.12

Removing

- 1 Remove the front floor. 76.10.12.
- 2 Remove the front seat base. 76.70.06.
- 3 Remove the gearbox. 37.20.01.
- 4 Remove the clutch slave cylinder
- 5 Withdraw the retainer staple.
- 6 Withdraw the bearing and sleeve. If required, press the bearing off the sleeve. Fit the replacement bearing with the domed face outwards from sleeve.

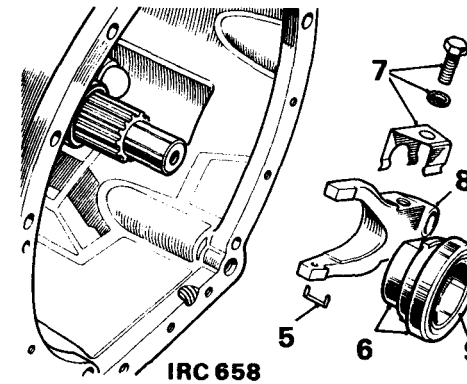

- 7 Remove the spring clip and fixings.
- 8 Withdraw the release lever assembly.

Refitting

- 9 Reverse 1 to 8. Lubricate the bearing sleeve inner diameter with PBC (Poly Butyl Cuprysil) grease.

CLUTCH PEDAL

Remove and refit 33.30.02

Removing

- 1 Remove the bonnet. 76.16.01.
- 2 Left hand steering models. See 33.20.01.
- 3 Disconnect the fluid pipe from the clutch master cylinder.
- 4 Disconnect the return spring from the clutch pedal.
- 5 Remove the fixings securing the clutch pedal bracket from inside the vehicle cab.

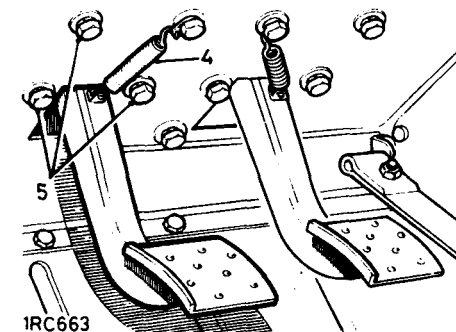

1RC663

- 6 Withdraw the bracket complete with pedal and master cylinder.
- 7 Remove the top cover and gasket from the clutch pedal bracket.
- 8 Remove the fixings from the end of the master cylinder push rod and push the rod into the master cylinder to clear the pedal trunnion.

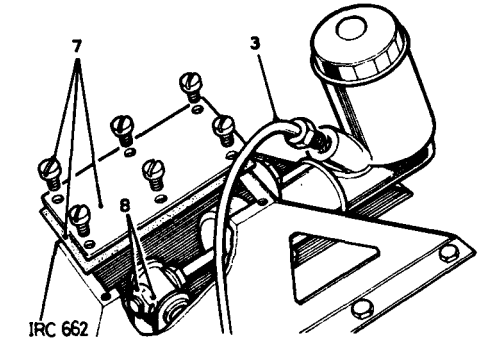

1RC 662

- 9 Using a suitable punch, drift out the pin from the pedal shaft.
- 10 Withdraw the pedal shaft.
- 11 Withdraw the clutch pedal complete with trunnion and bushes.
- 12 If required, remove the bushes, trunnion and distance piece from the clutch pedal.

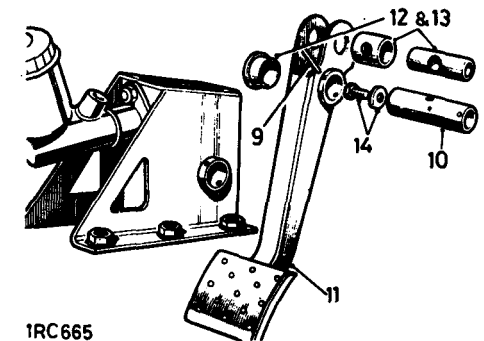

1RC665

Refitting

- 13 If removed, fit the distance piece, trunnion and bushes to the clutch pedal. Lubricate the trunnion and distance piece with general purpose grease on assembly. New pedal bushes must be reamed to 19,05 mm \pm 0,02 mm (0.750 in \pm 0.001 in).

continued

- 14 Remove the oil plug and washer from the pedal shaft. Fill the shaft bore with clean engine oil and refit the plug and washer.
- 15 Reverse 8 to 11.
- 16 Place the gasket in position on the securing flange of the brake pedal bracket. If necessary, use Bostik adhesive to retain the gasket.
- 17 Reverse 3 to 6.
- 18 Bleed the clutch hydraulic system. 33.15.01.

Clutch pedal and master cylinder setting

- 19 Remove the top cover and slacken both locknuts on the master cylinder push-rod.
- 20 Check the distance from the lower edge of the clutch pedal to the floor. The correct distance is 140 mm (5.5 in.).
- 21 Adjust the pedal stop, as required, to obtain the correct distance.
- 22 Adjust the master cylinder push rod until there is approximately 1,5 mm (0.062 in.) free play between the push rod and the master cylinder piston.
- 23 Tighten both locknuts.
- 24 Check the clutch pedal and ensure that there is a minimum of 6 mm (0.250 in.) free movement of the pedal before pressure is felt. If necessary, readjust the master cylinder push rod.
- 25 Fit the gasket and top cover to the clutch pedal bracket.
- 26 Reverse 1 and 2.

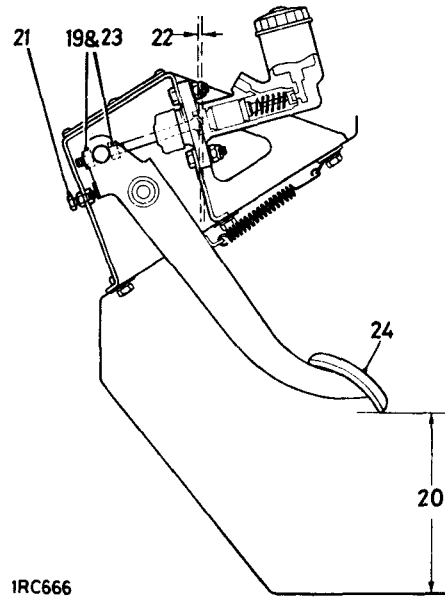
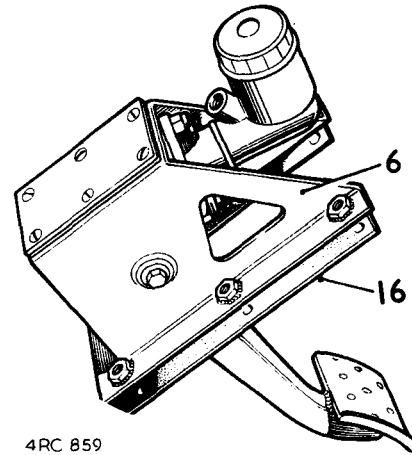

DATA

- Clutch pedal pivot bushes, reamed diameter.....
- Clutch pedal height setting.....
- Master cylinder push rod free play.....
- Clutch pedal free play (minimum).....

- 15,87 mm ± 0,02 mm (0.750 in. ± 0.001 in.)
- 140 mm (5.500 in.)
- 1,5 mm (0.062 in.)
- 6,0 mm (0.250 in.)

SLAVE CYLINDER

Remove and refit 33.35.01

Removing

- 1 Unscrew the bleed valve to release the hydraulic fluid.
- 2 Disconnect the fluid supply pipe from the slave cylinder.
- 3 Remove the two bolts securing the slave cylinder.
- 4 Withdraw the slave cylinder.

Refitting

- 5 Enter the push-rod through the hole in the rubber boots so that it locates correctly inside the cylinder.
- 6 Fit the slave cylinder bleed valve uppermost, and secure with the two bolts.
- 7 Fit the fluid supply pipe.
- 8 Bleed the clutch hydraulic system as described in operation 33.15.01.
- 9 Check the system for leaks with the brake pedal depressed and with the system at rest.
- 10 Fit the fluid pipe.

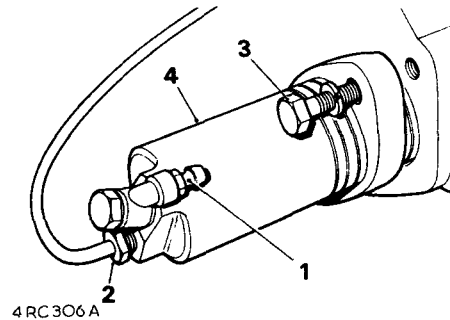

SLAVE CYLINDER

Overhaul 33.35.07

Dismantling

- 1 Remove the slave cylinder. 33.35.01.
- 2 Withdraw the dust cover.
- 3 Expel the piston assembly, applying low pressure air to the fluid inlet.
- 4 Withdraw the spring.

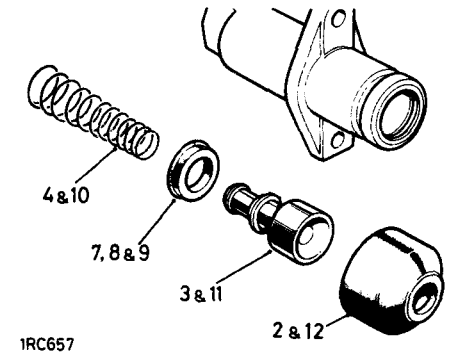

Inspecting

- 5 Clean all components with Girling cleaning fluid and allow to dry.
- 6 Examine the cylinder bore and piston, ensure that they are smooth to the touch with no corrosion, score marks or ridges. If there is any doubt, fit new replacement.
- 7 The seal should be replaced with a new component.

Assembling

- 8 Smear the seal with Castrol-Girling rubber grease and the remaining internal items with Castrol-Girling brake and clutch fluid.
- 9 Fit the seal, large diameter last, to the piston.
- 10 Locate the conical spring, small diameter first, over the front end of the piston.
- 11 Smear the piston with Castrol-Girling rubber grease and insert the assembly, spring end first, into the cylinder.
- 12 Fill the dust cover with Castrol-Girling rubber grease and fit the cover to the cylinder.
- 13 Refit the slave cylinder. 33.35.01.

FRONT OUTPUT SHAFT HOUSING

Remove and refit

37.10.05

Removing

- 1 Remove the front floor. 76.10.12.
- 2 Remove the seat base. 76.70.06.
- 3 Drain the gearbox lubricating oil.
- 4 Remove the transmission brake. 70.45.16.
- 5 Remove the transfer box. 37.29.25.
- 6 Remove the transfer gear selector shaft plunger.
- 7 Remove the top cover from the transfer box.
- 8 Remove the pinch bolt from the transfer selector fork.
- 9 Remove the front output shaft housing from the transfer box, taking care to catch the four wheel drive locking dog which will be released.
- 10 Withdraw the loose selector fork from the transfer box.

Refitting

- 11 If the selector shafts have been removed, refer to 37.10.06 for refitting procedure.
- 12 Place the transfer gear selector fork in position, with the threaded side of the pinch bolt hole towards the centre of the transfer box.
- 13 Smear both sides of the joint washer with a general purpose grease and place in position on the transfer box.
- 14 Offer the output shaft housing to the transfer box, carefully locating the transfer gear selector shaft through the selector fork by turning the flange if necessary to engage the splines of the locking dog over the output shaft.

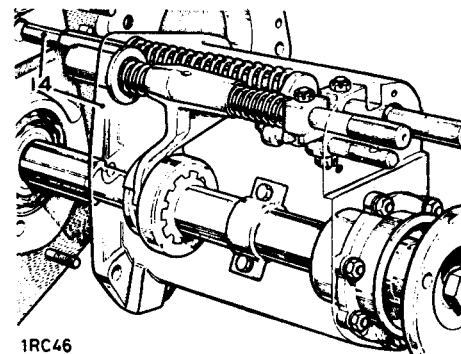
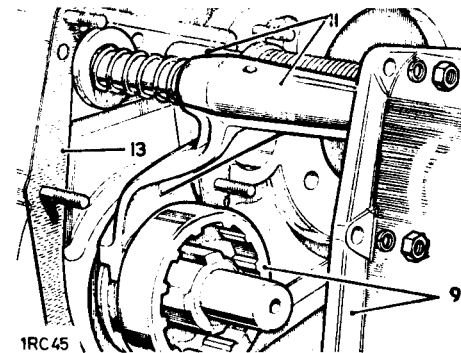
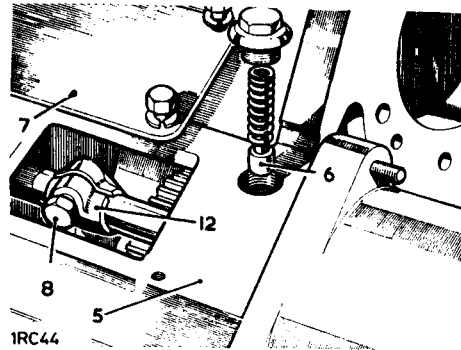

- 15 Complete the refitting by reversing the removal procedure. Ensure that the selector fork pinch bolt engages the groove in the selector shaft. This bolt will fit only one way.

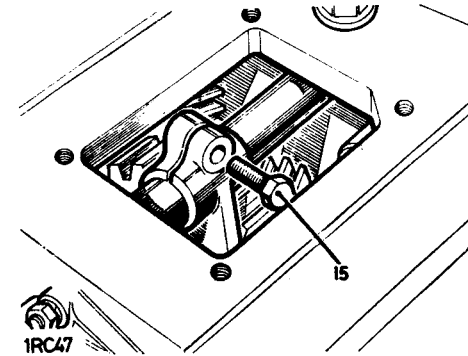

- 16 If the transfer box is of the all helical type, see 37.29.28, adjust the transfer travel stop as follows.
- 17 Engage four wheel drive, low ratio, and check the fit of the four wheel drive locking pin in the pivot shaft. The pin must be an easy slide fit.
- 18 If necessary, adjust the stop bolt to obtain this condition.
- 19 Tighten the locknut to secure the stop bolt.
- 20 Replenish the gearbox oil.

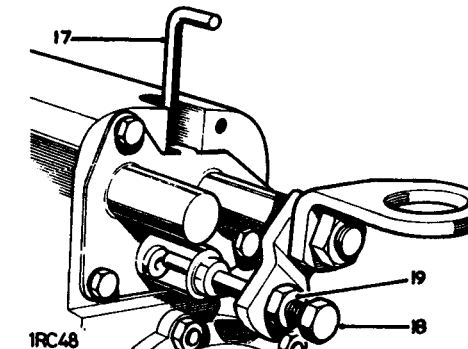

FRONT OUTPUT SHAFT HOUSING

Overhaul

37.10.06

Dismantling the housing

- 1 Remove the front output shaft housing. 37.10.05.
- 2 Remove the link from the transfer gear selector shaft.
- 3 Remove the four wheel drive control lever.

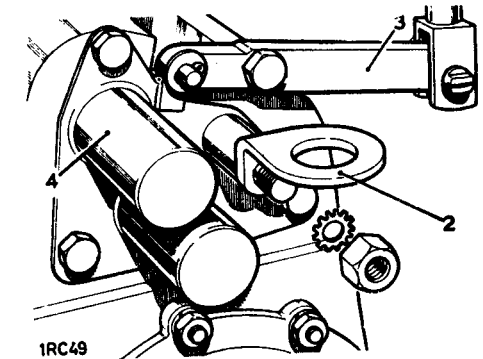

- 4 Remove the selector shaft dust cover.
- 5 Withdraw the selector shaft assemblies and the four wheel drive locking dog from the housing.

continued

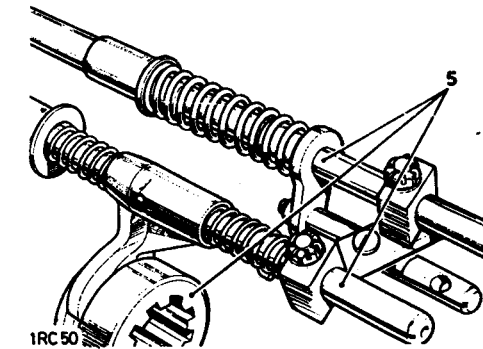

- 6 Remove the flange from the front output shaft.
- 7 Remove the oil seal retainer and gasket.
- 8 Press out the oil seal.
- 9 Remove the front output shaft from the housing.

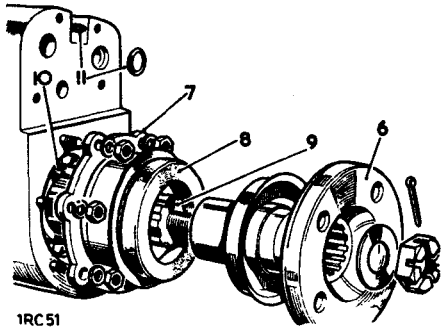

1RC51

- 10 Press out the bearing from the housing.
- 11 Remove the sealing rings for the four wheel drive locking pin and the transfer gear shaft.

Dismantling the four wheel drive selector shaft

- 12 Remove the block from the selector shaft.
- 13 Withdraw the springs and selector fork from the shaft.

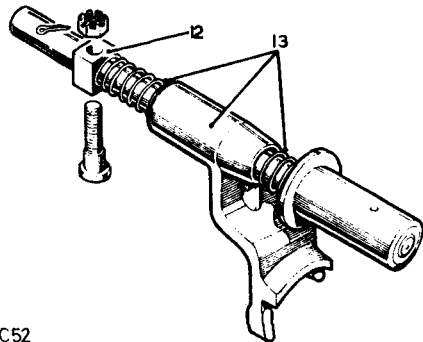

1RC52

Dismantling the transfer gear selector shaft

- 14 Slide the distance tube, bush, spring and pivot shaft assembly from the selector shaft.
- 15 Remove the block.
- 16 Remove the connector from the pivot shaft.
- 17 Remove the coupling from the pivot shaft.

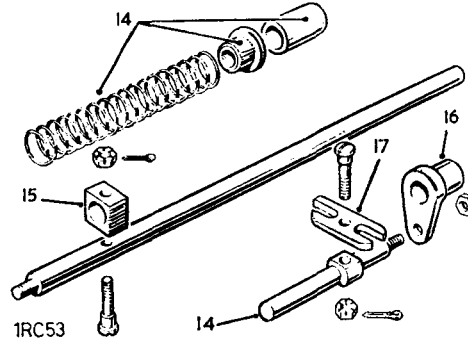

1RC53

Dismantling the front output shaft

- 18 Remove the fixings.
- 19 Lift the two halves of the oil thrower from the shaft.

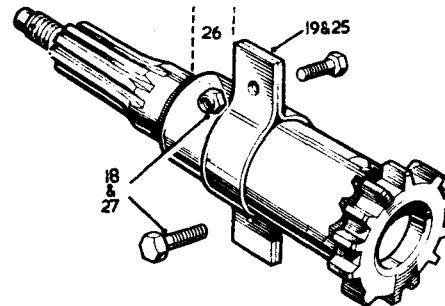

1RC55

Inspecting

- 20 Renew any components which show obvious wear or damage. Examine the bush in the four wheel drive control lever and renew if necessary.
- 21 Examine the four wheel drive selector fork and bushes, and renew as necessary. New bushes must be pressed flush with the end faces of the fork boss, and reamed in position to 15,887 mm + 0,012 mm (0.6255 in. + 0,0005 in.) diameter, and must be a sliding fit on the selector shaft.
- 22 Check the four wheel drive selector shaft springs, the free length should be 69,8 mm (2.75 in.).

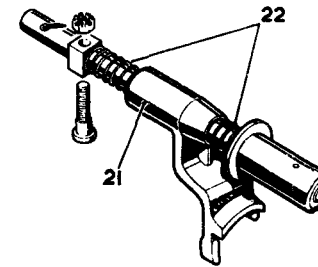

1RC54

- 23 Check the transfer selector shaft spring, the free length should be 181,76 mm (7.156 in.).
- 24 Examine the bush in the rear end of the front output shaft. The bush must be a sliding fit on the front end of the transfer box output shaft and must be firmly retained in its bore. If bush replacement is necessary, press the new bush flush with the end of the shaft and ream in position to 22,2 mm ± 0,013 mm (0.8755 in. ± 0.0005 in.) diameter.

Assembling the front output shaft

NOTE: If a new output shaft is being fitted try the bronze bush over the front end of the rear output shaft and ensure that it is not tight to prevent subsequent seizure.

- 25 Fit the oil thrower to the front output shaft, do not fully tighten the fixings at this stage.

- 26 Position the oil thrower 25 mm (1 in.) from the shoulder on the shaft, as illustrated.
- 27 Tighten the fixings.

Assembling the transfer gear selector shaft

- 28 Fit the connector to the pivot shaft noting the relationship of the counter-sink in the hole at the other end of the shaft.
- 29 Do not fully tighten the fixings at this stage.
- 30 Fit the coupling to the pivot shaft locating the extended arm correctly, as illustrated.

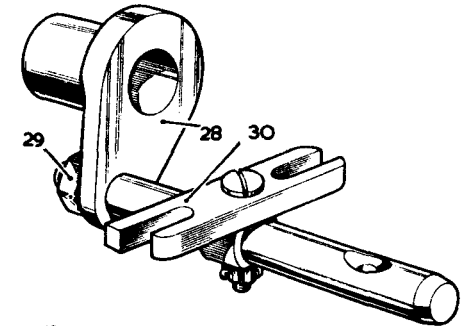

1RC56

- 31 Fit the block to the transfer gear selector shaft, locating the fixings so that the nut and split pin are on the same side of the shaft as the plunger grooves.
- 32 Locate the pivot shaft assembly in position on the transfer gear selector shaft.
- 33 Engage the coupling with the special screw.

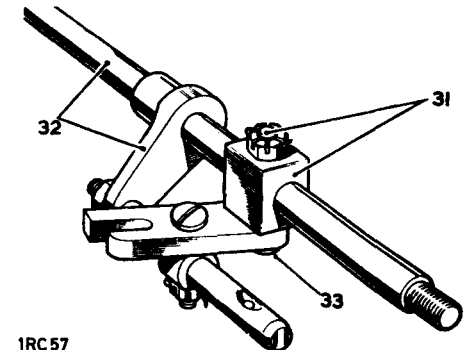

1RC57

34 Fit the spring, locating bush and distance tube on to the selector shaft.

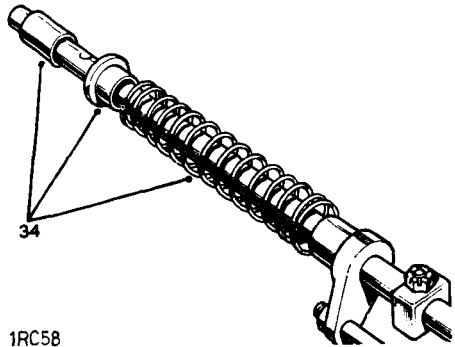

1RC58

Assembling the four wheel drive selector shaft.

- 35 Fit the springs and selector fork to the shaft. Note that the two springs are identical and are interchangeable.
36 Fit the block to the selector shaft.

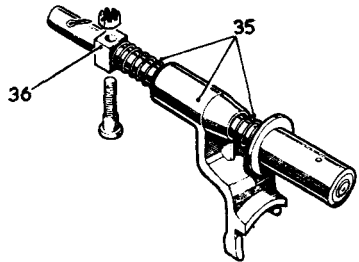

1RC59

Assembling the housing

- 37 Fit the oil seal for the front output shaft, lipped side inward, into the retainer, with a smear of sealant on the seal outside diameter.
38 Press the bearing into the housing.
39 Smear both sides of the joint washer with general purpose grease, and fit the oil seal retainer and joint washer to the housing.
40 Fit the front output shaft.

41 If the mud shield has been removed, refit it, dished side first, to the output flange.

42 Fit the flange to the output shaft.

43 Tighten the securing nut to a torque figure of 11,75 kgf. m (85 lbf. ft.).

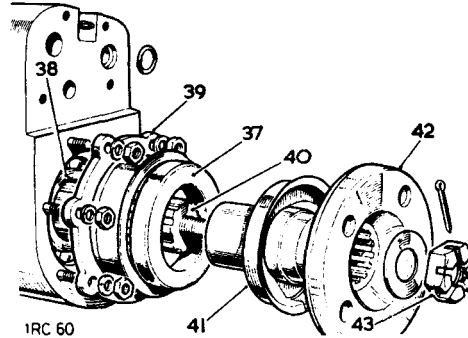

1RC60

Pre-alignment of selector shafts

44 Locate the two selector shafts together by engaging the coupling with the special screws.

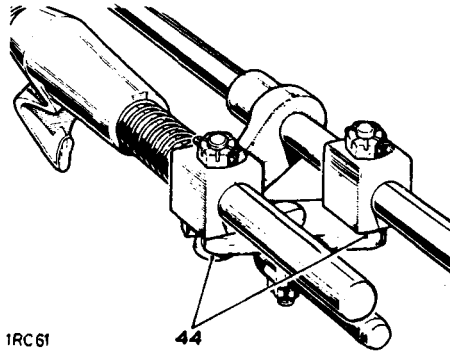

1RC61

45 Locate the selector shaft assembly into the front face of the output shaft housing.

46 Fit the four wheel drive locking pin, engaging it in the countersunk hole in the pivot shaft. This will ensure correct radial alignment of the pivot shaft to the connector.

47 Fully tighten the nut to secure the connector to the pivot shaft.

48 Remove the locking pin and withdraw the selector shafts as one unit, then without disturbing their alignment, engage them into their correct location in the output shaft housing, while at the same time fitting the four wheel drive locking dog over the output shaft and into the selector fork.

49 If convenient, it will be advantageous at this stage to fit the front output shaft housing to the transfer box 37.10.05.

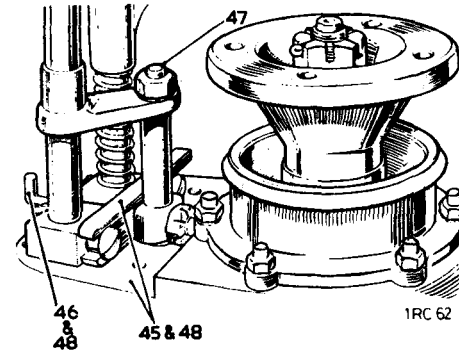

1RC62

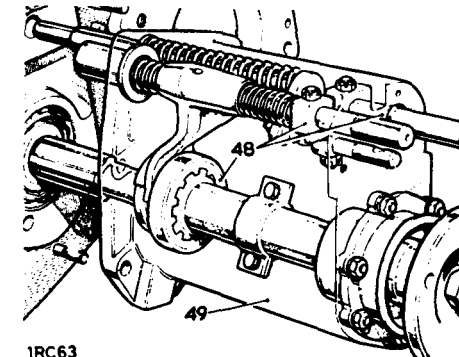

1RC63

50 Fit the sealing rings for the transfer gear selector shaft and the four wheel drive locking pin.

51 Grease the two shafts and fit the selector shaft dust cover, using Bostik sealant 772 on the joint face.

52 Fit the lever to the selector shaft, but do not fully tighten the fixing pending setting the four wheel drive lever during floor refitting.

53 Fit the transfer gearshaft link.

54 Fit the four wheel drive locking pin and control lever.

55 Refit the front output shaft housing. 37.10.05.

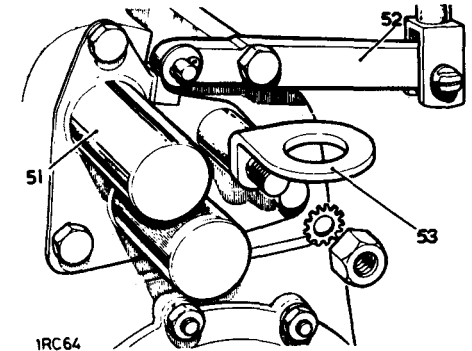

1RC64

DATA

Four wheel drive selector fork bush	15,887 to 15,899 mm (0.6255 to 0.6260 in.) reamed diameter
Four wheel drive selector shaft springs, free length	69,8 m (2.75 in.).
Transfer selector shaft spring, free length	181,76 mm (7.156 in.).
Bush for output shaft	22,200 to 22,213 mm (0.8755 to 0.8760 in.) reamed diameter.

BELL HOUSING

Remove and refit

37.12.07

Removing

- 1 Remove the front floor. 76.10.12
- 2 Remove the seat base. 76.70.06.
- 3 Drain the gearbox lubricating oil.
- 4 Remove the gearbox assembly complete. 37.20.01.
- 5 Remove the main gearchange lever. 37.16.04.
- 6 Remove the clutch withdrawal unit. 33.25.12.
- 7 Disconnect the transfer gear lever from the bracket at the bell housing. The fixings illustrated are alternatives.
- 8 Withdraw the lever, taking care to retain the spring strip located between the lever ball and link.

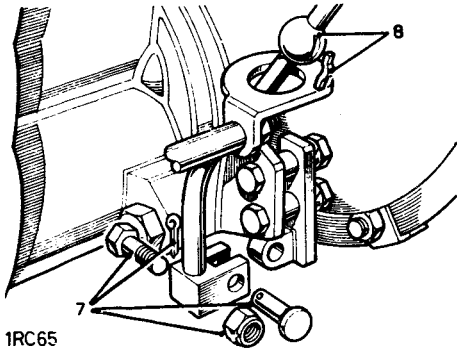

1RC65

- 9 Fully adjust the transmission brake to lock 'hard on'.
- 10 Remove the primary pinion cover and oil seal assembly.
- 11 Withdraw the joint washer.
- 12 Select any gear.
- 13 Remove the layshaft securing bolt and washer. DO NOT remove the circlip from the primary pinion.
- 14 Remove the bell housing fixings.
- 15 Retain the constant gear and conical distance piece which are released during the following procedure.
- 16 Hold the layshaft depressed fully rearwards and ease the housing from the gearbox.

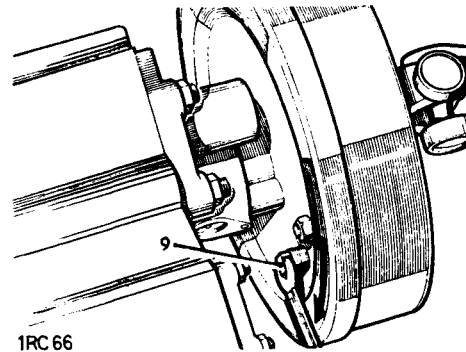

1RC66

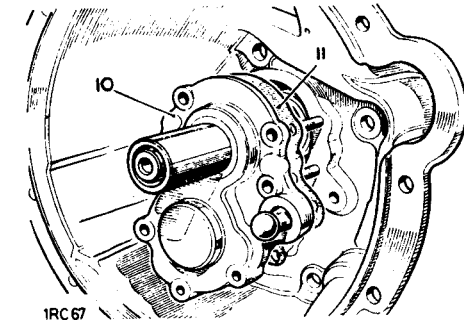

1RC67

Refitting

- 17 Two of the bell housing to gearbox fixings are special fitted bolts, and must be positioned diagonally opposite each other.
- 18 Smear both sides of the joint washer with a general purpose grease and place in position on the gearbox.

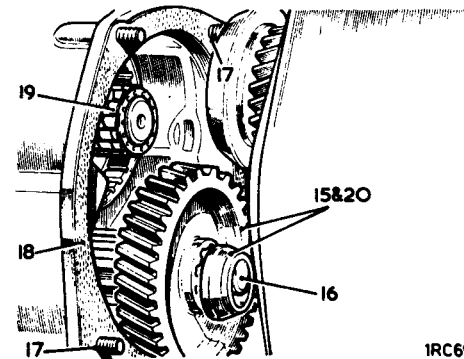

1RC69

- 19 Ensure that the roller bearing for the primary pinion is in position.
- 20 Locate the conical distance piece and constant gear in place, in mesh with the primary pinion, on the rear face of the bell housing.
- 21 Retain the constant gear and conical distance piece in position, by holding through the layshaft bearing, from the inside of the bell housing, then offer the bell housing to the gearbox, using special care to align the constant gear with the splines on the layshaft.
NOTE: If the layshaft securing bolt has a nylon locking patch it should be discarded in favour of the latest standard setbolt. Smear with Loctite 601 and tighten to 6,9 kgf m (50 lbf ft).
- 22 Complete the reassembly by reversing 1 to 14. Smear the layshaft securing bolt with Loctite 601 and tighten to a torque figure of 6,9 kgf m (50 lbf ft).

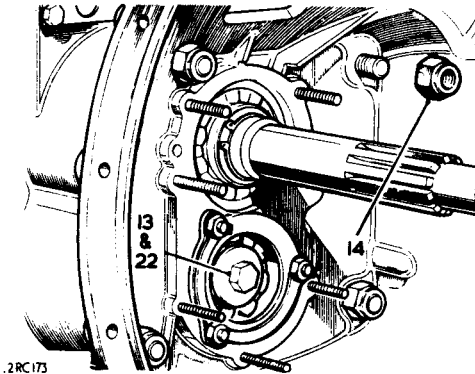

2RC173

- 23 Check and replenish the gearbox lubricating oil.
- 24 Adjust the transmission brake. 70.45.09.

BELL HOUSING

Overhaul

37.12.08

Dismantling

- 1 Remove the bell housing. 37.12.07.
- 2 Remove the layshaft bearing retainer and bearing plate.
- 3 Press the layshaft bearing from the bell housing.

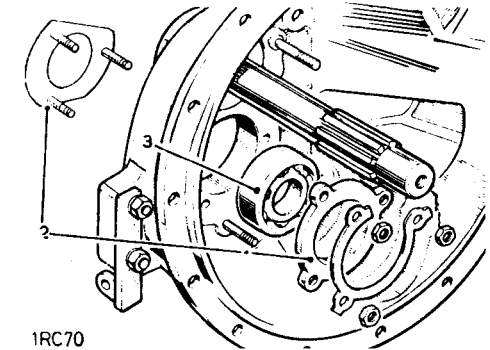

1RC70

- 4 Remove the circlip and distance washer.
- 5 Press out the primary pinion.
- 6 Remove the bearing retaining plates.
NOTE: These are handed plates.
- 7 Press out the primary pinion bearing.

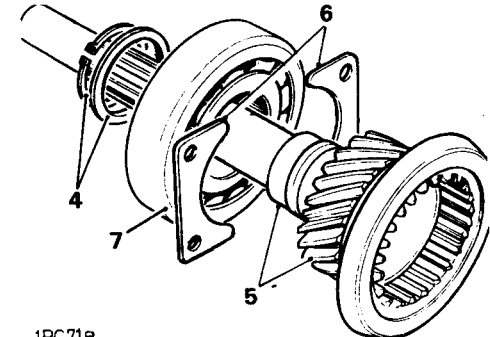

1RC71B

Assembling

- 8 Reverse 5 to 7
- 9 Fit the distance washer and position a new circlip in the retaining groove.
- 10 Check the end-float between the primary pinion and the distance washer. End-float must be the minimum obtainable, selecting a suitable distance washer from the range available. It should be possible to turn the washer without feeling any end-float.
- 11 Fit the selected distance washer and circlip.

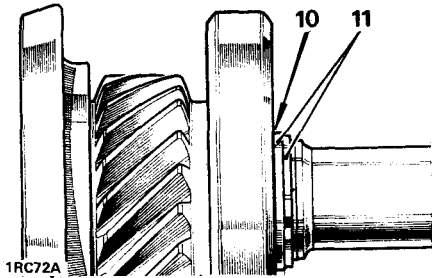

- 12 Reverse 1 to 3.

GEARBOX MAIN CASING

Remove and refit 37.12.40

NOTE: If it is required to change the rear main oil seal only, it is not necessary to completely dismantle the gearbox. The oil seal is accessible after removing the intermediate gear and the mainshaft gear from the transfer box, see 37.29.25 and 37.20.25 for details.

Removing

- 1 Remove the front floor. 76.10.12.
- 2 Remove the seat base. 76.70.06.
- 3 Drain the gearbox lubricating oil.
- 4 Remove the gearbox assembly complete. 37.20.01.
- 5 Remove the transmission brake. 70.45.16.
- 6 Remove the transfer box. 37.29.25.
- 7 Remove the main gear change lever. 37.16.04.
- 8 Remove the clutch withdrawal unit. 33.25.12.

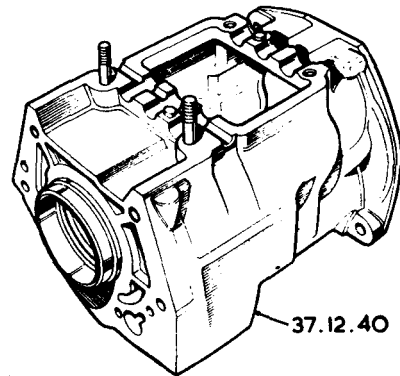

1RC73

- 9 Remove the bell housing. 37.12.07.
- 10 Remove the selector shafts. 37.16.31.
- 11 Remove the layshaft. 37.20.19.
- 12 Remove the mainshaft. 37.20.25.
- 13 When 1 to 12 are completed the gearbox main casing is released and can be dismantled as described under 'Overhaul', 37.12.43.

Refitting

- 14 Reverse 1 to 12.

GEARBOX MAIN CASE

Overhaul 37.12.43

Dismantling

- 1 Remove the gearbox main case. 37.12.40.
- 2 Prise the oil seal from the rear of the mainshaft bearing housing.
- 3 Remove the circlip retaining the bearing housing to the rear face of the gearbox.

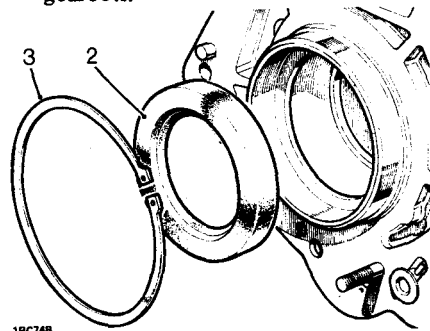

1RC74B

- 4 Press out the housing, complete with bearing, in a forward direction.
- 5 Remove the circlip.
- 6 Press the mainshaft rear bearing from the housing.
- 7 With the case warm, drive out the layshaft bearing outer race, using a suitable drift applied through the two extractor holes provided in the case rear face. (See also item 8.)
- 8 An alternative method is to use a mandrel, approximately 300 mm (12 in.) long by 43,50 mm (1.687 in.) diameter, so that it is a tight fit in the outer race. Warm the gearbox case and outer race, keep the mandrel as cool as possible. With the casing warm, insert the mandrel into the outer race which will shrink on to the mandrel and withdraw easily.

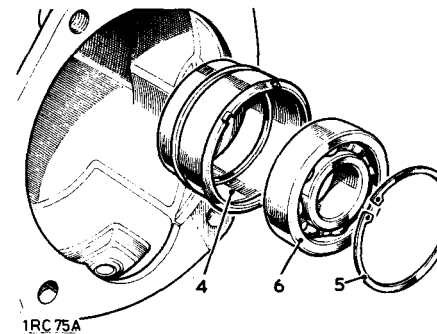

1RC75A

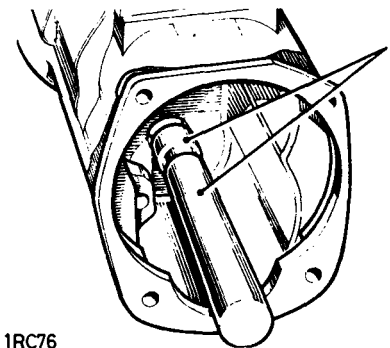

1RC76

- 9 The remaining oil drain and filler plugs, studs, dowels and retaining plate for selector shaft oil seals, can be removed as required. See 37.20.13 for removal of reverse idler gear and shaft if required.

Inspecting

- 10 Check all components for wear and damage.
- 11 Ensure that the two dowels in the gearbox top face, and the two dowels in the rear face, are secure.

Assembling

- 12 Press the layshaft rear bearing outer race, lipped edge first, into the gearbox case.
- 13 Smear the outside diameter of the mainshaft rear bearing with Loctite Retaining Compound, Grade 601 and press the bearing into the housing.
- 14 Retain with a circlip.
- 15 Fit the main shaft rear oil seal, lipped side first, into the bearing housing.
- 16 Smear the outside diameter of the bearing housing with Loctite Retaining Compound (Grade 601), Part No. 600303 and press it into position.

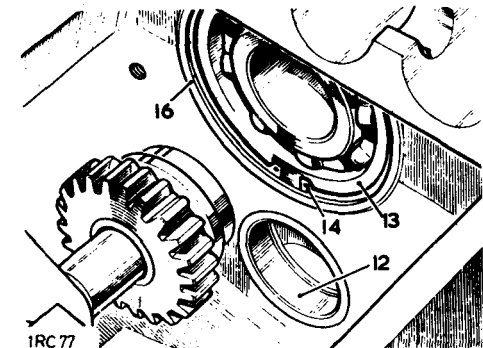

1RC77

NOTE: The gearbox should not be filled with lubricating oil or used for twenty-four hours, to allow the Loctite to fully cure.

- 17 Fit the retaining circlip to the groove in the bearing housing where it protrudes through the rear face of the gearbox.
- 18 Refit the gearbox main case. 37.12.40.

MAIN GEARCHANGE LEVER

Remove and refit 37.16.04

Removing

- 1 Remove the front floor. 76.10.12.
- 2 Remove the fixings.
- 3 Remove the main gearchange lever complete.
- 4 To prevent loss, lift off the top cover plate and rubber seal from the bell housing.

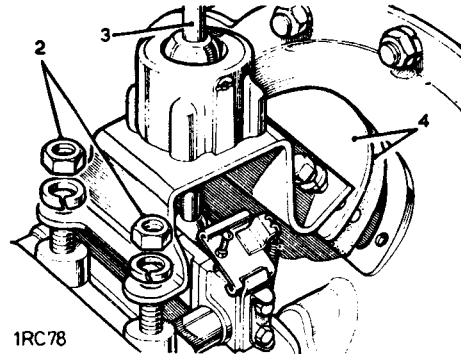

1RC78

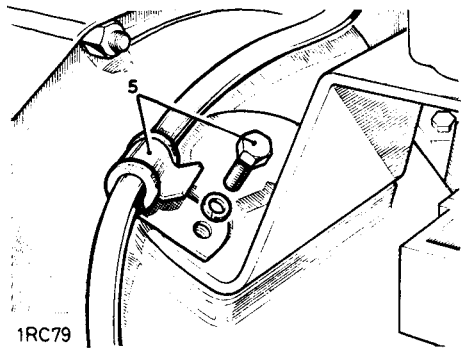

1RC79

Refitting

- 5 Reverse 1 to 4, noting that a retaining clip for the speedometer cable locates under the head of the front left hand gearchange lever securing bolt.

MAIN GEARCHANGE LEVER

Overhaul 37.16.10

Dismantling

- 1 Remove the gearchange lever. 37.16.04.
- 2 Remove the fixings at the mounting plate.
- 3 Remove the lever housing from the mounting plate.
- 4 Remove the lever housing circlip.

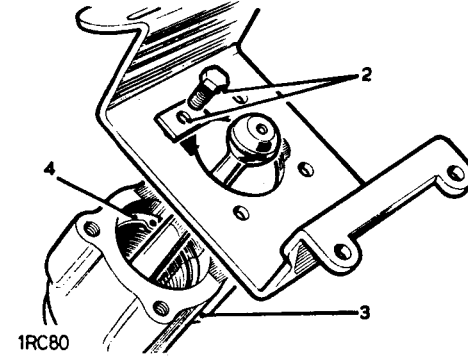

1RC80

- 5 Withdraw the spring, rubber 'O' ring (later models) and spherical seat.
- 7 Lift out the gearchange lever.
- 8 Withdraw the lever ball locating pin.
- 9 Examine the components visually and renew any that show obvious wear or damage.

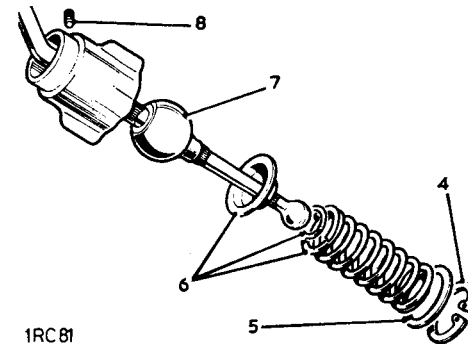

1RC81

Assembling

- 10 Reverse 2 to 8.
- 11 Ensure that the lever locating pin engages the slot in the lever ball.
- 12 Secure the pin by peening.
- 13 Refit the gearchange lever. 37.16.04.

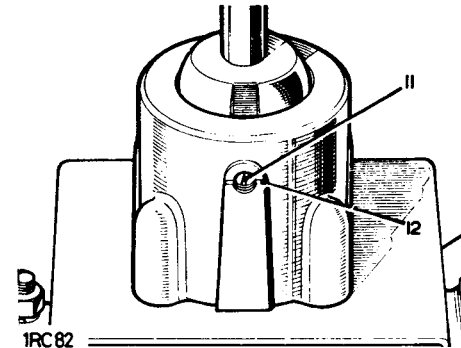

1RC82

REVERSE STOP FOR MAIN GEARCHANGE LEVER

Remove, refit and adjust 37.16.28

Removing

- 1 Remove the front floor. 76.10.12.
- 2 Remove the hinge adjuster.
- 3 Remove the hinge and bracket from the reverse selector shaft.
- 4 Detach the two springs.

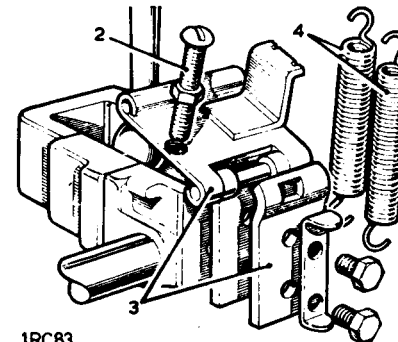

1RC83

Refitting

- 5 Reverse 1 to 4. Adjust the reverse stop before fitting the front floor, items 6 to 9.

Adjusting

- 6 Release the fixings and slide the reverse stop inspection cover up the four wheel drive selector lever.

NOTE: If the gearbox cover does not incorporate an inspection cover, then the adjustment must be carried out before the gearbox cover is fitted.

- 7 Slacken the adjusting screw locknut.
- 8 Adjust the screw so that the hinge rides easily up the gear lever when reverse gear is selected, while at the same time appreciable resistance is felt on moving the gear lever to the reverse position.

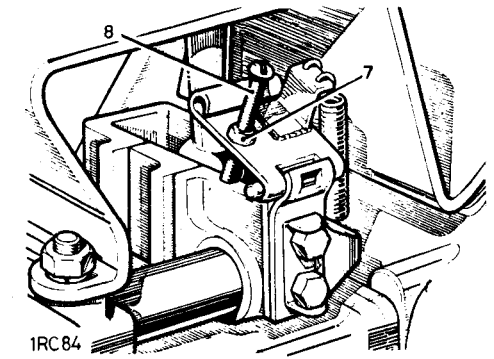

1RC84

- 9 Ensure that 1st gear engages correctly, if there is any tendency to simultaneously engage reverse gear, readjust the reverse stop.

MAIN GEARCHANGE SELECTORS

Remove and refit

37.16.31

Removing

- 1 Remove the front floor. 76.10.12.
- 2 Remove the seat base. 76.70.06.
- 3 Remove the main gearchange lever. 37.16.04.
- 4 Remove the three selector springs and pack the drillings in the top cover with grease, to retain the selector balls when the cover is removed.
- 5 Remove the top cover and joint washer from the gearbox and collect the three selector balls.

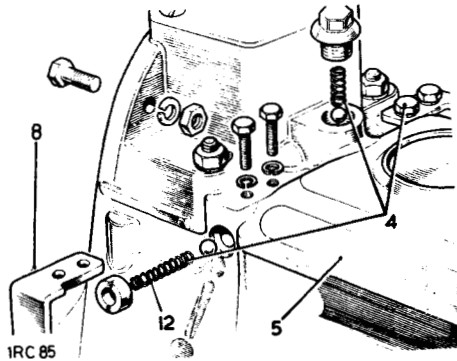

- 6 Select third gear.
- 7 Lift the first/second selector shaft, do not attempt to remove but lift and withdraw the third/fourth selector shaft.
- 8 Lift, twist and remove the first/second selector shaft.
- 9 Lift, turn and withdraw the reverse selector shaft.

NOTE: No force is required to withdraw any of the selector shafts.

DATA

Reverse gear selector shaft stop setting . . .

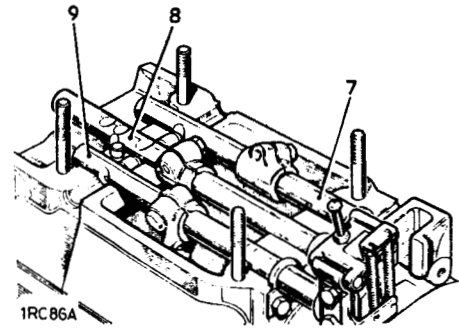

Refitting

- 10 Reverse 3 to 9.
- NOTE:** If a joint washer was not previously fitted to the top cover, then a joint washer should now be fitted.
- 11 Select reverse gear.
 - 12 Adjust the reverse gear stop bolt so that there is 0,05 mm (0.002 in.) minimum clearance between the selector shaft and the end of the bolt.
 - 13 Tighten the locknut.

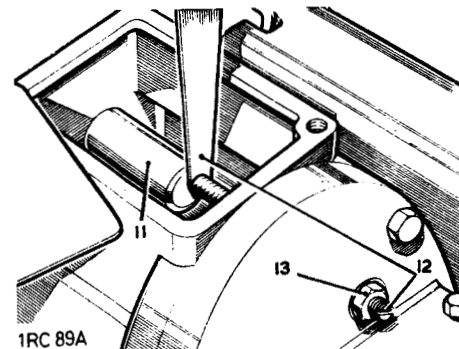

NOTE: If the transfer box has been removed from the main gearbox, the foregoing adjustment must be carried out after the transfer box has been refitted.

- 14 Reverse 1 and 2.

0,05 mm (0.002 in) minimum clearance between shaft and stop

MAIN GEARCHANGE SELECTORS

Overhaul

37.16.34

NOTE: See the Note on page 37—20 at the end of Section 37.

Dismantling

- 1 Remove the gearchange selectors. 37.16.31.
- 2 Remove the reverse selector stop. 37.16.28.
- 3 Remove the pinch bolts.
- 4 Withdraw the selector forks.
- 5 Withdraw the seals.

Inspecting

- 6 Examine the components visually and replace worn or damaged items.

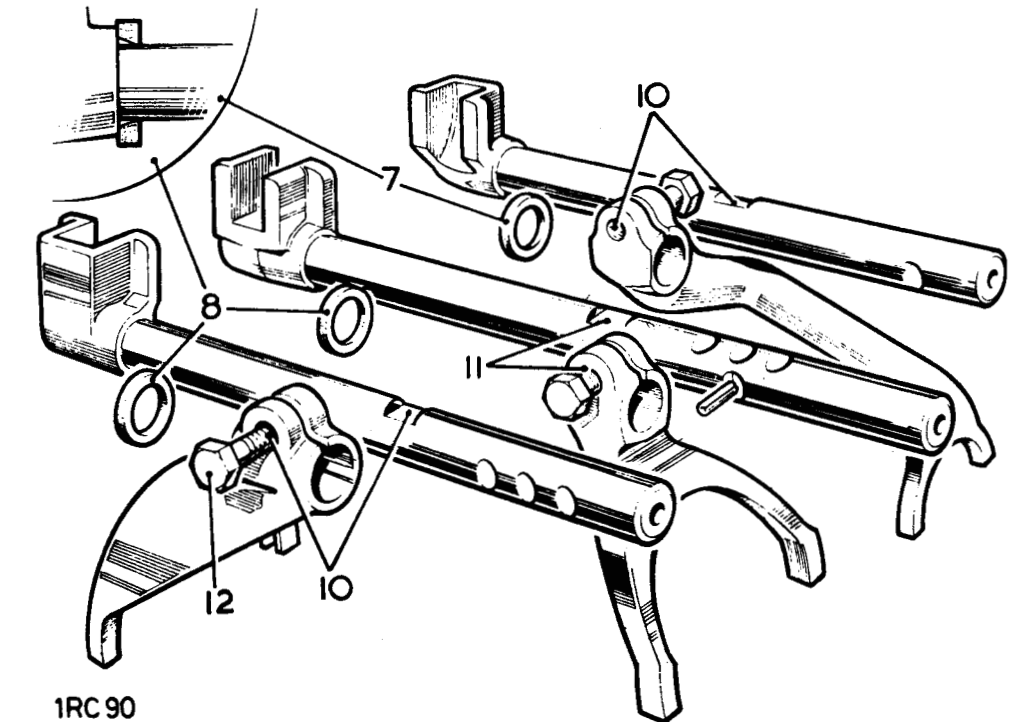

Assembling

- 7 Fit the larger diameter tapered seal to the reverse shaft, with the thinner edge of the seal toward the front of the shaft.
- 8 Fit the two remaining tapered seals, thinner edges toward the front of the shafts.
- 9 Position the selector forks on the shafts.
- 10 Align the pinch bolt holes with the grooves on top of the shafts.
- 11 On the first/second gear selector, the groove required is the one nearest to the front of the shaft.
- 12 Fit the pinch bolts. There is radial movement between the selector fork and shaft before the pinch bolt is tightened, and the fork should be secured in the mid position and the bolts tightened to 2,7 kgf m (20 lbf ft).
- 13 Reverse 1 and 2.

GEARBOX ASSEMBLY

Remove and refit

37.20.01

Removing

- 1 Remove the front floor. 76.10.12.
- 2 Remove the seat base. 76.70.06.
- 3 Drain the gearbox lubricating oil.
- 4 Remove the rear propeller shaft fixings at the transmission brake.
- 5 Move aside the shaft.

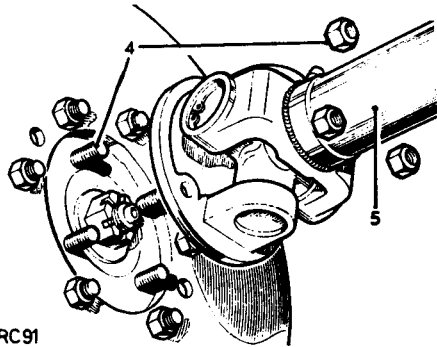

1RC91

- 6 Remove the front propeller shaft fixings at the front output coupling.
- 7 Move aside the shaft.

NOTE: If the vehicle is fitted with any optional equipment driven from the gearbox, it must be disconnected at the gearbox. Refer to separate publication for details of optional equipment.

- 8 Disconnect the hand brake expander rod from the relay lever.

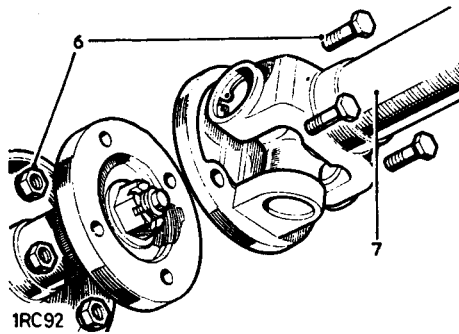

1RC92

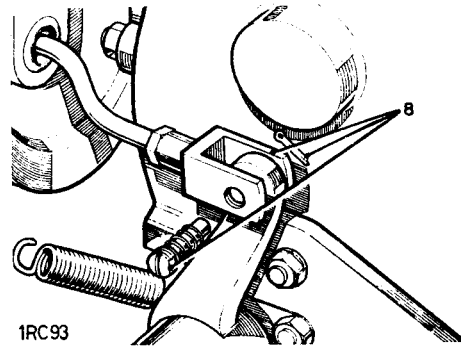

1RC93

- 9 Remove the brake lever and relay fixings.
- 10 Remove the brake lever and relay mechanism.

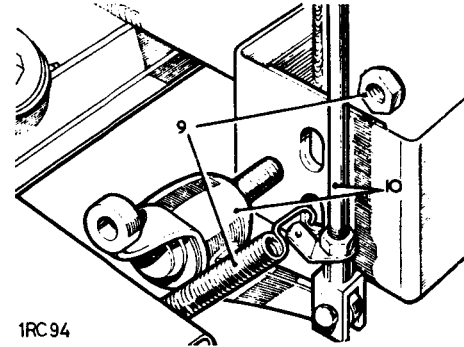

1RC94

- 11 Left hand steering models only. Remove the brake lever cross-shaft.
- 12 Disconnect the speedometer cable from the gearbox.

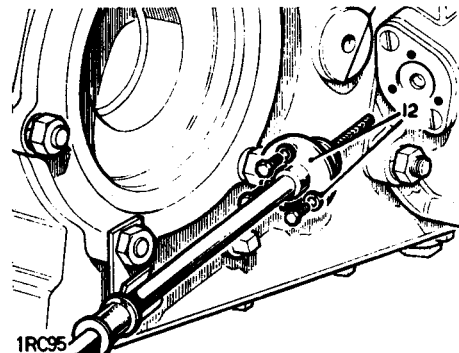

1RC95

NOTE: On certain models, the engine exhaust pipe is located above the gearbox left hand rear mounting, and where applicable, the exhaust pipe must be moved clear. Also check the location of the engine earth strap, on certain models it is fitted between the gearbox and chassis and must therefore be disconnected.

- 13 Remove the fixings from two rear mountings for the gearbox.

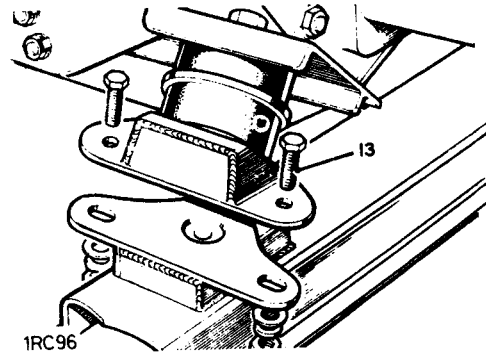

1RC96

- 14 On certain models, a tie rod is fitted between the gearbox and chassis. Where applicable, release the bracket at the bell housing and move the tie rod clear.

- 15 Remove the clutch slave cylinder from the bell housing.

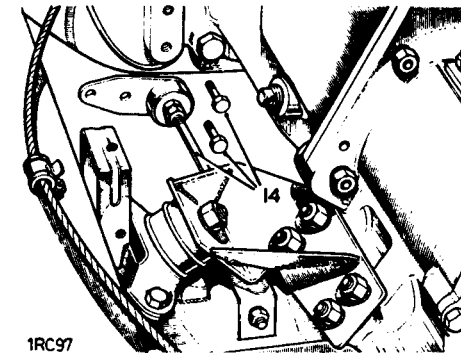

1RC97

- 16 Jack up the rear of the engine sufficient to insert a 25 mm (1 in.) thick block of wood between the flywheel housing and chassis, to retain the

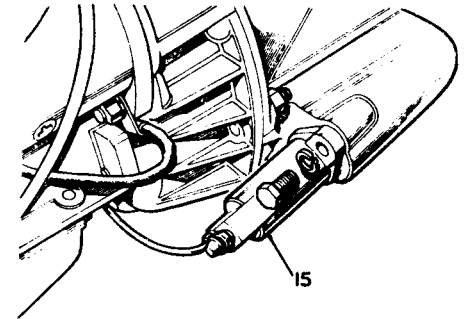

1RC98

engine position when the gearbox is removed.

- 17 Place a suitable sling around the gearbox and tension it sufficient to take the weight.

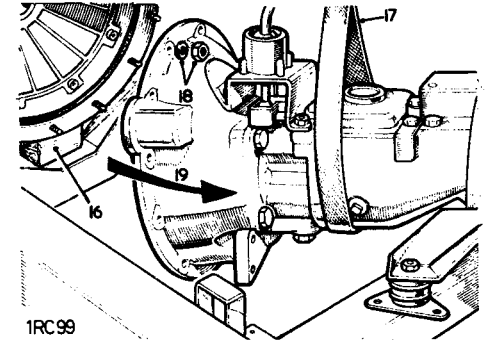

1RC99

- 18 Remove the remaining fixings securing the bell housing to the flywheel housing.
- 19 Carefully withdraw the gearbox rearwards clear of the clutch and lift from the vehicle.

Refitting

- 20 Smear the splines of the primary pinion, the clutch centre and the withdrawal unit abutment faces with Molybdenum disulphide grease such as Rocol MTS 1000.
- 21 Check that the push-rod for the clutch slave cylinder is fitted to the release lever in the bell housing, then complete the refitting by reversing instructions 1 to 19.
- 22 Bleed the clutch hydraulic system as necessary. 33.15.01.

REVERSE IDLER GEAR AND SHAFT

Remove and refit, 1 to 3 and 10 to 12
37.20.13
Overhaul 1 to 12
37.20.14

Removing

- 1 Remove the gearbox main case. 37.12.40
- 2 Warm the gearbox case and drive out the reverse gear idler shaft from inside the case.
- 3 Lift out the reverse wheel assembly and collect the thrust washer and spacer on later assemblies with needle bearing.

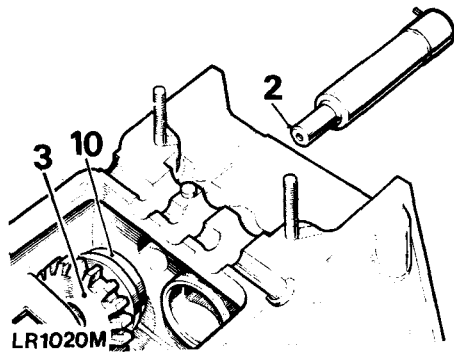

Overhauling Early type with brush

- 4 Check the bush in the reverse wheel assembly. If a new bush is required it must be secured by peening after being pressed into position, and then reamed to 20,637 mm + 0.025 mm (0.8125 in. + 0.001 in.) diameter.

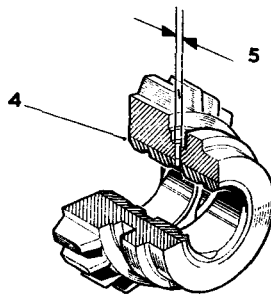

- 5 After reaming and peening as already described, drill a 3,18 mm (0.125 in.) diameter hole through the bush, using the existing hole in the gear as a pilot. Afterwards remove all fraze from the bore.

Later type with needle bearing

- 6 Remove the two circlips.
- 7 Remove the two washers.
- 8 Withdraw the needle bearing.
- 9 Examine gear and bearing and reassemble securing with the two circlips.

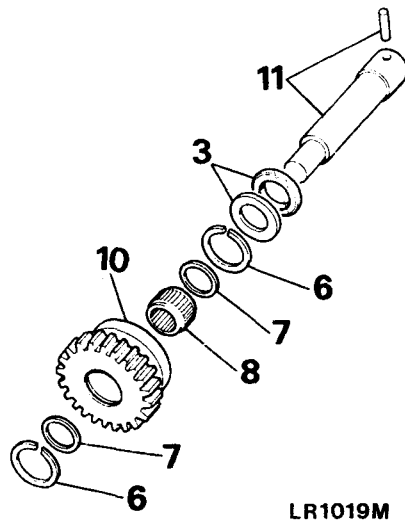

Refitting

- 10 Fit the reverse wheel assembly with the selector groove to the rear of the gearbox.
- 11 Press in the reverse shaft until flush with gearbox rear face and with the needle bearing type insert the spacer and thrust washer. Align the spring pin with the slot provided in the rear face.
- 12 Reverse instruction 1.

LAYSHAFT

Remove and refit 37.20.19

NOTE: See the Important Note on page 37—20 at the end of Section 37.

Removing

- 1 Remove the front floor. 76.10.12.
- 2 Remove the seat base. 76.70.06.
- 3 Drain the gearbox lubricating oil.
- 4 Remove the gearbox assembly complete. 37.20.01.
- 5 Remove the main gearchange lever. 37.16.04.
- 6 Remove the clutch withdrawal unit. 33.25.12.
- 7 Remove the bell housing. 37.12.07.
- 8 Withdraw the third/fourth gear synchroniser from the mainshaft.
- 9 Manoeuvre the layshaft forward and downwards to clear the mainshaft.
- 10 Withdraw the layshaft.
- 11 The first, second and third gears are integral with the layshaft and cannot be removed.
- 12 If required, press the rear bearing inner race from the layshaft.
- 13 If required, refer to 37.12.43 for removal of layshaft rear bearing outer race.

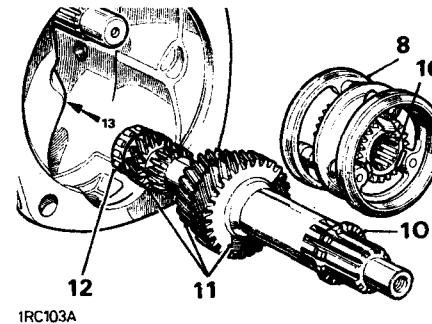

Refitting

- 14 Reverse 11 as necessary.
- 15 Reverse 12 as necessary.
- 16 Fit the third/fourth synchroniser to the main shaft with the recessed end of the inner member towards the third speed gear.
- 17 Fit the layshaft and rear inner bearing member assembly.
- 18 Place the bell housing joint washer in position.
- 19 Ensure that the roller bearing for the primary pinion is in position.
- 20 Locate the conical distance piece and constant gear in place, in mesh with the primary pinion, on the rear face of the bell housing.
- 21 Retain the constant gear and conical distance piece in position, by holding from inside the bell housing, then offer the bell housing to the gearbox, aligning the constant gear with the splines on the layshaft.
- 22 Fit the bell housing fixings.
- 23 Loosely fit the layshaft securing bolt and washer and check that the layshaft has definite but minimum end-float.
- 24 To adjust, replace the conical distance piece, available in a range of three thicknesses.
- 25 Tighten the layshaft securing bolt, torque loading 8,5 kgf m (60 lbf ft).
- 26 Reverse 1 to 7.

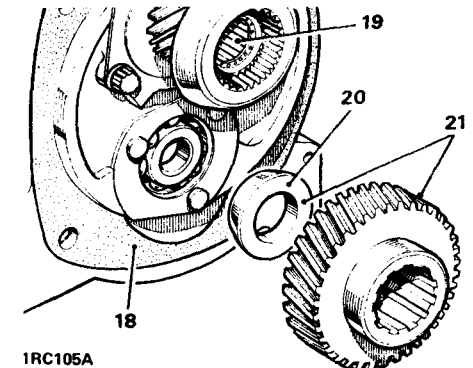

MAINSHAFT ASSEMBLY

Remove and refit 37.20.25

Service tool: 600300, tool for mainshaft nut

Removing

- 1 Remove the front floor. 76.10.12.
- 2 Remove the seat base. 76.70.06.
- 3 Drain the gearbox lubricating oil.
- 4 Remove the gearbox assembly complete. 37.20.01.
- 5 Remove the main gearchange lever. 37.16.04
- 6 Remove the clutch withdrawal unit. 33.25.12.
- 7 Remove the bell housing. 37.12.07.
- 8 Remove the selector shafts. 37.16.31.
- 9 Remove the layshaft. 37.20.19.
- 10 Remove the rear bearing housing from the transfer box.

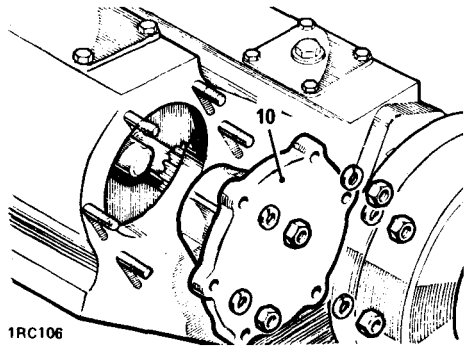

1RC106

- 11 Open the tab washer.
- 12 Remove the mainshaft nut. 600300.

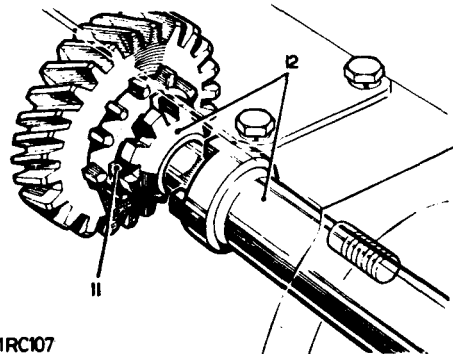

1RC107

- 13 Withdraw the tab washer and shim washer.
- 14 Withdraw the mainshaft transfer gear.
- 15 Remove the oil thrower.
- 16 Drive out the mainshaft from the gearbox.

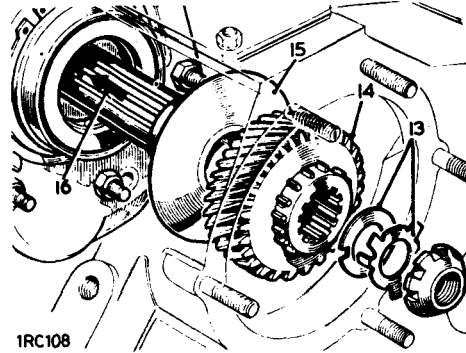

1RC108

Refitting

NOTE: If any mainshaft components have been renewed, the checks described under 'Mainshaft overhaul' 37.20.31 must be carried out.

- 17 Reverse 1 to 16.

MAINSHAFT ASSEMBLY

Overhaul 37.20.31

Dismantling

- 1 Remove the mainshaft. 37.20.25.

Mainshaft rear end

- 2 Withdraw the thrust washer.
- 3 Lift off the first speed gear.
- 4 Withdraw the bush for the first speed gear.

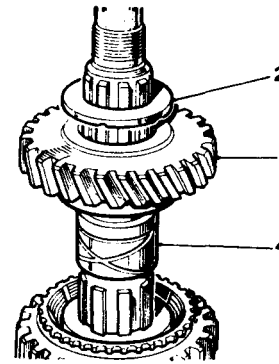

1RC109

- 5 Withdraw the synchroniser rear cone.
- 6 Lift off complete the first/second speed synchroniser unit.
- 7 Withdraw the synchroniser front cone.

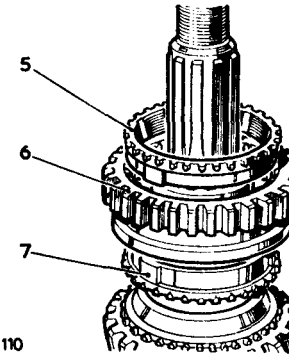

1RC110

Mainshaft front end

- 8 Remove the retainer ring from the groove in the mainshaft.
- 9 Withdraw the thrust washer, then the following items:
 - 10 Third speed gear.
 - 11 Distance sleeve.
 - 12 Second speed gear.
- 13 If it is required to remove the thrust washer for the second speed gear, first remove the locating peg for the distance sleeve; the peg is a press fit in the mainshaft.

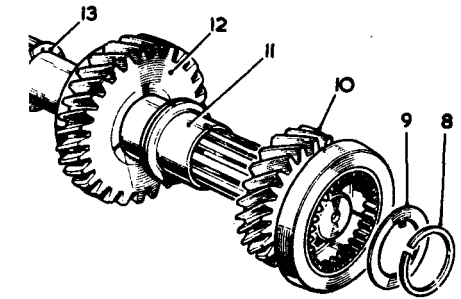

1RC111

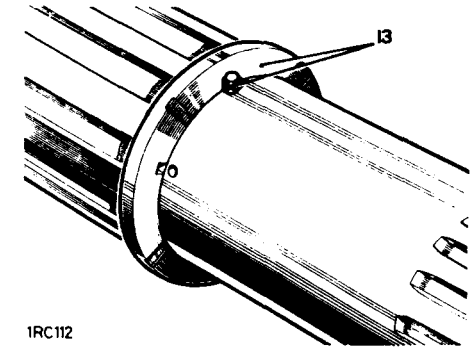

1RC112

First/second speed synchroniser

- 14 Before dismantling, take precautions to avoid the loss of components as they are released. Three springs, balls and sliding blocks are retained in the unit under spring pressure.
- 15 Dismantle the synchroniser assembly, first pushing down the sliding blocks to free the balls from the retaining grooves in the outer member.

Inspecting

- 16 Examine all components for wear and damage.
- 17 Discard the mainshaft spring ring. Use a new replacement on assembly.
- 18 Check the synchronising clutch for third/fourth gears for wear, the detent springs can be replaced if required. A load of 6,5 to 9 kg. (15 to 20 lb.) should be required to actuate the clutch against the combined detent springs pressure.

Assembling

First/second speed synchroniser

- 19 Note the position of the longer splines on the inner member, formed by the offset groove.
- 20 Align the detent spring bores in the inner member with the ball retaining grooves in the outer member.
- 21 Fit the inner member to the outer member, entering the longer splines on the inner member at the gear teeth side of the outer member.
- 22 Repeat 20 and 21 in alternative positions and select the best position for easy slide fit.
- 23 Position the sliding blocks on the inner member, radiused faces outwards.
- 24 Locate the springs through the sliding blocks and into the housing bores in the inner member.
- 25 Position the balls on the spring ends; press home in sequence and retain by hand.
- 26 Lift the outer member to retain the balls. Continue lifting until the balls spring home into the retainer grooves.

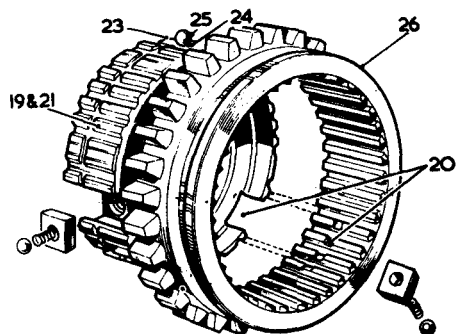

Mainshaft, front end

- 27 If the thrust washer for the second speed gear has been removed from the mainshaft, place the washer in position chamfered face first, engaging it over its locating peg. Do not fit the locating peg for the distance sleeve at this stage.
- 28 Fit the second speed gear, coned face last, to the end of the distance sleeve with the larger slot.

- 29 Slide the gear and sleeve assembly on to the mainshaft to abut with the thrust washer.
- 30 Holding the sleeve hard against the thrust washer, check the end-float of the second speed gear, this must be 0,10 to 0,18 mm (0.004 to 0.007 in.).

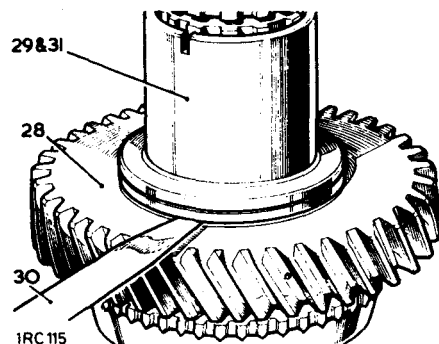

- 31 The end-float of the second and third speed gears is controlled by the length of the distance sleeve. With a new sleeve, the clearance may be excessive and can be corrected by rubbing down the applicable end face of the sleeve on a face plate and emery cloth. In the event of insufficient clearance, a new sleeve must be fitted.
- 32 Retain the second speed gear and distance sleeve on the mainshaft.
- 33 Fit the third speed gear and thrust washer.
- 34 Hold the thrust washer hard against the sleeve and check the end-float of the third speed gear, this must be 0,10 to 0,18 mm (0.004 to 0.007 in.). End-float adjustment is as already described in item 31.

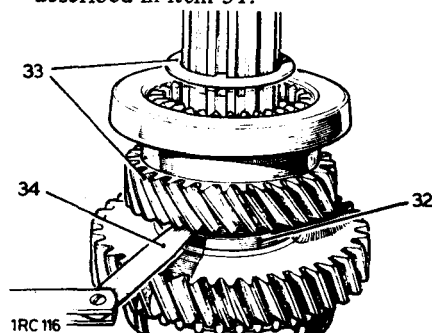

- 35 Remove the gears and distance sleeve from the mainshaft and refit the thrust washers and distance sleeve only, retain in position with the old spring ring.
- 36 Check the end float of the distance sleeve, this must be 0,03 to 0,20 mm (0.001 to 0.008 in.). Adjustment is made by changing either of the thrust washers which are available in a range of thicknesses.
- 37 When the end-float of the mainshaft gears and distance piece are correct, remove the spring ring, thrust washer for third speed gear and the distance sleeve.
- 38 If removed, fit the distance sleeve locating peg to the mainshaft, ensuring that the thrust washer for the second speed gear is engaged on its locating peg.
- 39 Fit the second speed gear, distance sleeve, third speed gear and thrust washer to the mainshaft.
- 40 Retain with a new spring ring.

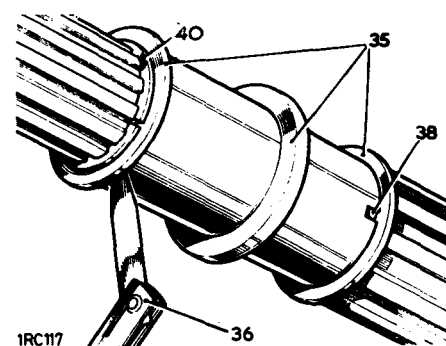

Mainshaft rear end

- 41 Position the mainshaft with the rear end uppermost.
- 42 Position a synchroniser cone on to the second speed gear.
- 43 Fit the first/second synchroniser unit to the shaft, reverse gear side uppermost.
- 44 Position a synchroniser cone on to the synchroniser inner member.
- 45 Fit the bush for first speed gear with the circular oil groove end uppermost. Ensure that the bush rear face is 0,05 to 0,18 mm (0.002 to 0.007 in.) below the end of the mainshaft splines; check by temporarily fitting the thrust washer, stepped face uppermost, and measuring the clearance between the bush and the thrust washer.
- 46 Fit the first speed gear.
- 47 Fit the thrust washer, stepped face uppermost.

continued

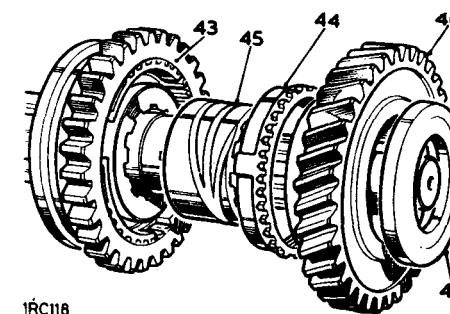

- 48 Fit the third/fourth synchroniser unit to the main shaft; noting that it must be fitted with the recessed end of the inner member towards the third gear.

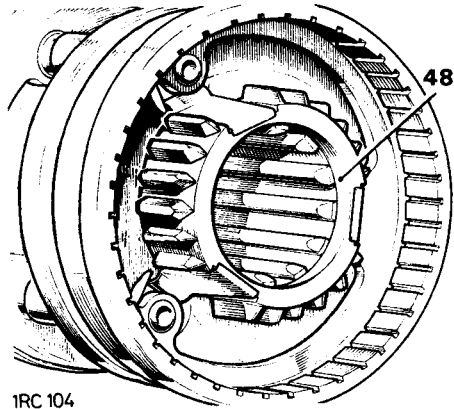

SPEEDOMETER DRIVE HOUSING

Remove and refit 37.25.09

Removing

- 1 Remove the transmission brake. 70.45.16.
- 2 Disconnect the speedometer cable from the gearbox.

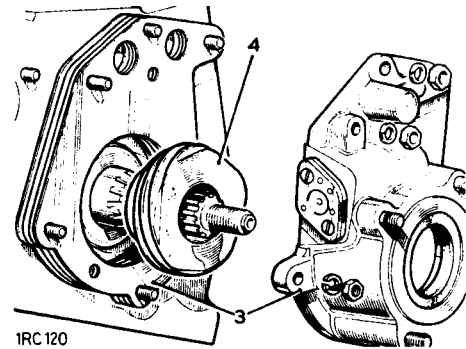
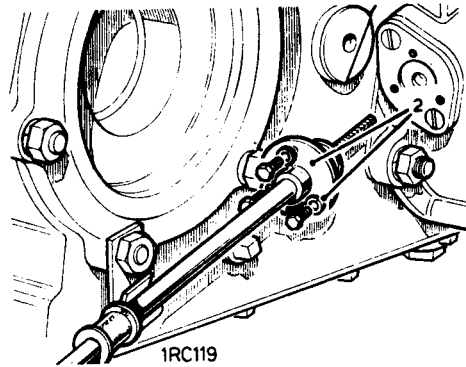

- 3 Remove the speedometer drive housing complete with shims.
- 4 Withdraw the speedometer drive worm.

Refitting

- 5 Reverse 1 to 4. If necessary, replenish the gearbox lubricating oil.

SPEEDOMETER DRIVE HOUSING

Overhaul 37.25.13

Dismantling

- 1 Remove the speedometer drive housing. 37.25.09.
- 2 Remove the pinion retainer fixings.
- 3 Withdraw the retainer and gasket.
- 4 Withdraw the pinion sleeve.
- 5 Remove the oil seal and 'O' ring.
- 6 Withdraw the speedometer pinion.
- 7 Remove the output shaft oil seal from the speedometer housing.

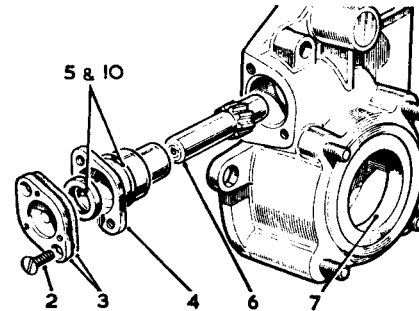

1RC 121

Inspecting

- 8 Examine the pinion teeth and the speedometer drive worm for wear.
- 9 Check the sleeve which should be a slide fit on the pinion.

Assembling

- 10 Fit the oil seal, lipped side inwards, and 'O' ring to the sleeve.
- 11 Fit the pinion and sleeve, ensuring that the relieved face on the sleeve will be towards the speedometer drive worm when assembled.
- 12 Fit the output shaft oil seal, lipped side inward, using jointing compound on the seal outer diameter. The housing may be warmed to facilitate assembly.
- 13 Refit the drive housing. 37.25.09.

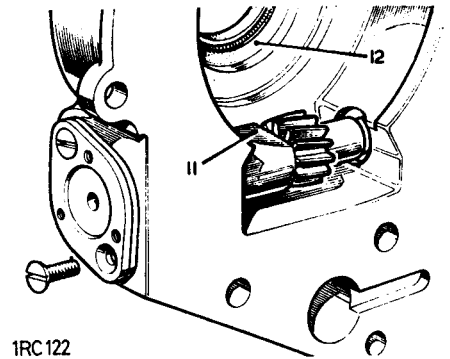

1RC 122

DATA

Third/fourth gear synchronising clutch load
 End float of second speed gear
 End float of third speed gear
 End float of distance sleeve
 End float of first speed gear
 Clearance between first gear bush rear face
 and thrust washer

6,5 to 9 kg. (15 to 20 lb.).
 0,10 to 0,18 mm (0.004 to 0.007 in.)
 0,10 to 0,18 mm (0.004 to 0.007 in.)
 0,03 to 0,20 mm (0.001 to 0.008 in.)
 0,10 mm to 0,20 mm (0.004 to 0.008 in.)
 0,05 to 0,18 mm (0.002 to 0.007 in.);
 adjust bush length to suit.

INTERMEDIATE GEAR ASSEMBLY

Remove and refit 37.29.25

See 37.29.28.

Operations 1-18 and 24-27.

TRANSFER GEARBOX

Remove and refit

37.29.25

Service tool: 605862, intermediate shaft extractor

Removing

- 1 Remove the front floor. 76.10.12.
- 2 Remove the seat base. 76.70.06.
- 3 Drain the gearbox lubricating oil.
- 4 Disconnect the front propeller shaft from the gearbox.
- 5 Remove the transmission brake. 70.45.16.

NOTE: If the vehicle is fitted with any optional equipment driven from the transfer box, it must be disconnected at the transfer box. Refer to separate publication for details of optional equipment.

- 6 Disconnect the speedometer cable from the gearbox.
- 7 Disconnect the transfer gear lever from the bracket at the bell housing. The fixings illustrated are alternatives.
- 8 Withdraw the lever, taking care to retain the spring strip, located between the lever ball and link.

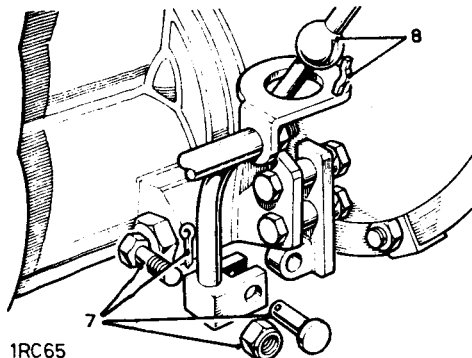

- 9 Remove the brake lever and relay fixings.
- 10 Remove the hand brake lever and relay mechanism.
- 11 Left hand steering models only. Remove the hand brake cross-shaft.

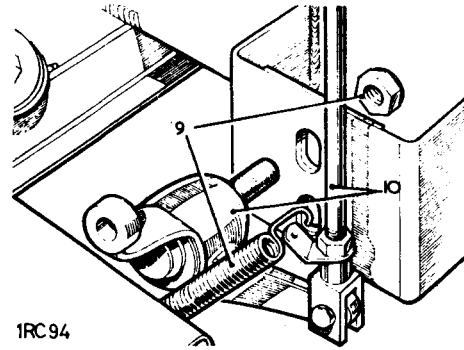

NOTE: On certain models, the engine exhaust pipe is located above the gearbox, left hand rear mounting, and where applicable, the exhaust pipe must be moved clear. Also check the location of the engine earth strap, on certain models it is fitted between the gearbox and chassis and must, therefore, be disconnected.

- 12 Remove the fixings from the two rear mountings for the gearbox.

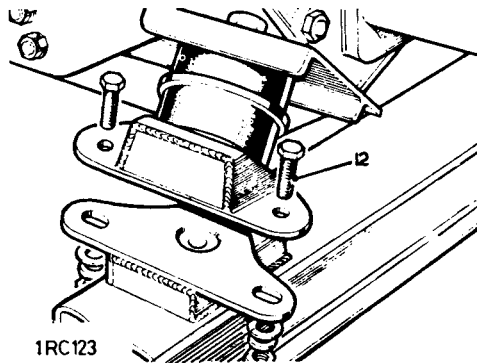

- 13 Jack up the rear of the engine sufficient to insert a 25 mm (1 in.) thick block of wood between the flywheel housing and the chassis to support the gearbox.

- 14 Remove the bottom cover plate and gasket from the transfer box.

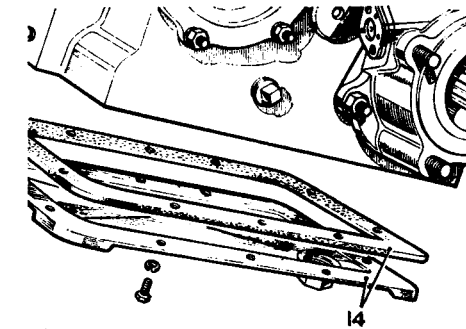

- 15 Remove the mainshaft rear bearing housing, or if fitted, the power take off drive unit.

- 16 Remove the fixings from the retaining plate for the intermediate shaft.

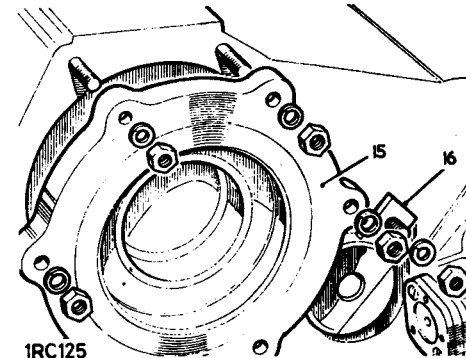

- 17 Support the intermediate gear by hand while using Service Tool 605862 to withdraw the intermediate shaft complete with retaining plate and oil seal 'O' ring. Withdraw the intermediate gear and roller bearings through the bottom of the casing.

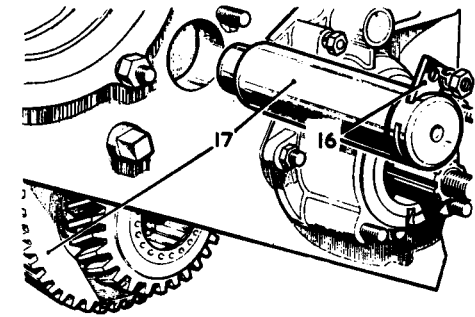

- 18 Remove the thrust washers and if fitted, shims located between each end of the intermediate gear and casing.

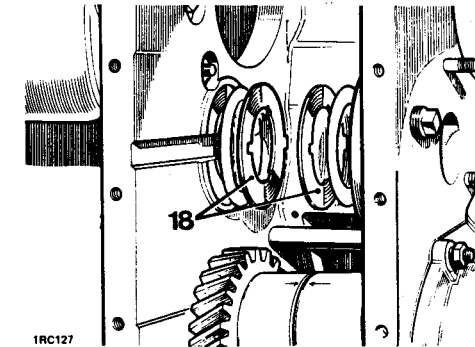

- 19 Remove the internal fixings.
- 20 Remove the external fixings.
- 21 Withdraw the transfer gearbox and joint washer from the main gearbox.

continued

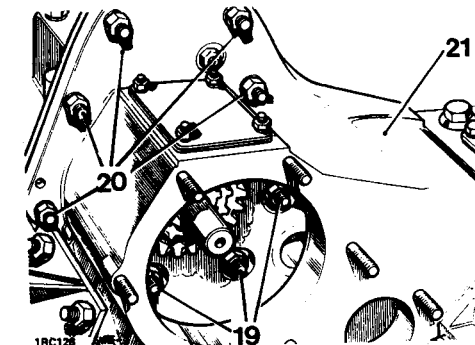

Refitting

- 22 Smear both sides of the joint washer with general purpose grease and place it in position on the main gearbox.
- 23 Fit the transfer box to the main gearbox, engaging the dowel locations.
- 24 Refit the roller bearings to the intermediate gear and fit any shims for the intermediate gear, between the thrust washers and the casing, ensuring that the thrust washer bronze faces are towards the intermediate gear. Use a little general purpose grease to retain in position.

NOTE: If the intermediate gear, bearings or thrust washers have been renewed, the gear end-float must be checked and adjusted, as described under 'Transfer box overhaul' 37.29.28.

- 25 Locate the intermediate gear, complete with roller bearings, in position in mesh with the high and low gear wheels.
- 26 Fit the intermediate shaft, together with its oil seal 'O' ring and retaining plate through the casing, shims, thrust washers and intermediate gear, tapping it lightly home when the spigotted end of the shaft engages its location in the front of the casing. The shaft must be a light tap fit.
- 27 Reverse 1 to 16. When refitting the bottom cover plate gasket, smear both sides with jointing compound.

TRANSFER GEARBOX (ALL HELICAL GEAR TYPE)**Overhaul**

37.29.28

Service tool: 243241 thread protector

Dismantling**General**

- 1 There are two types of transfer box in use, one utilises a helical and spur gear arrangement, while the other is of all helical design. The only visible external difference is a selector shaft adjuster, fitted to the front output shaft housing on the all helical box only. Identify the gearbox type before proceeding. Because the overhaul instructions for the two types carry the same operation number (37.29.28) but are printed separately, the applicable description is added to the operation title and to each continuing page.

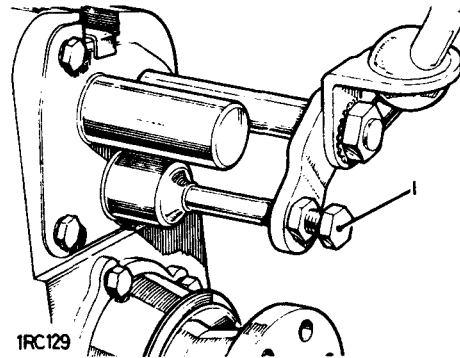

- 2 Remove the transfer gearbox. 37.29.25.
- 3 Remove the front output shaft housing. 37.10.05.
- 4 Remove the speedometer drive housing. 37.25.09.
- 5 Remove the circlip retaining the front bearing outer race.
- 6 Place two 16 mm (0.625 in.) diameter distance pieces between the rear face of the low gear wheel and the transfer box.

- 7 Retaining the distance pieces in position, use a soft mallet to drive the shaft rearwards until the low gear wheel just abuts the distance pieces.
- 8 Insert a mild steel chisel between the bush for the high gear wheel and the front bearing and prise the bearing outward approximately 6 mm (0.250 in.).

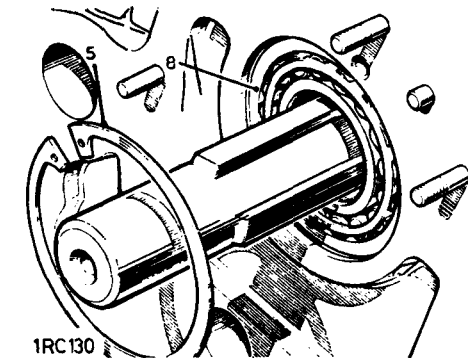
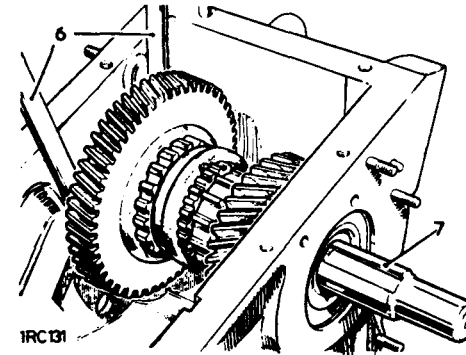

- 9 Part the change speed inner member and high gear wheel by hand.
- 10 Rotate the output shaft to locate the position of the shaft peg.
- 11 Using a suitable piece of wire, locate the slot in the high gear wheel thrust washer over the peg in the output shaft.
- 12 Retaining the distance pieces in position, use a soft-face mallet to drive the shaft rearwards until it can be withdrawn by hand complete with roller bearing, thrust washer and two locating pegs.

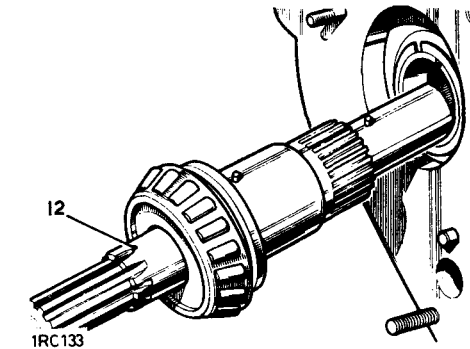
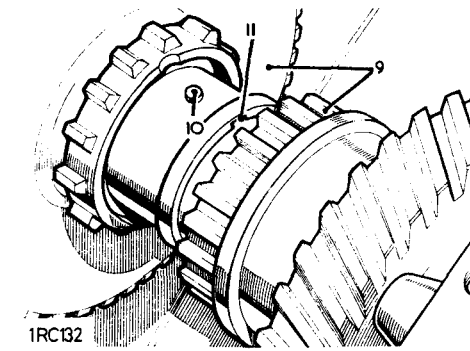

- 13 Withdraw the high and low speed gear assembly together with the front bearing from the transfer box.
- 14 Press the rear bearing and thrust washer from the output shaft. The low speed gear may be used as a press block for removal of the rear bearing.

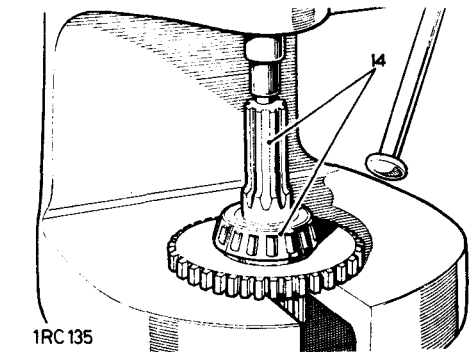

(ALL HELICAL GEAR TYPE)

- 15 Press the front bearing outer race from the transfer box.
- 16 Remove the circlip, retaining plate and roller bearing from the mainshaft rear bearing housing.

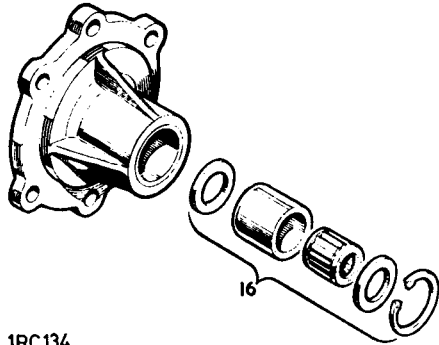

1RC134

Inspection

- 17 Inspect the following components and renew any which show obvious wear or damage. Refer to the illustration for aid to identification.
- 18 Bearing for output shaft, rear.
- 19 Thrust washer for low gear wheel.
- 20 Low gear wheel.
- 21 Bush for low gear wheel.
- 22 Outer member for transfer change speed.
- 23 Inner member for transfer change speed.
- 24 Thrust washer for high gear wheel.

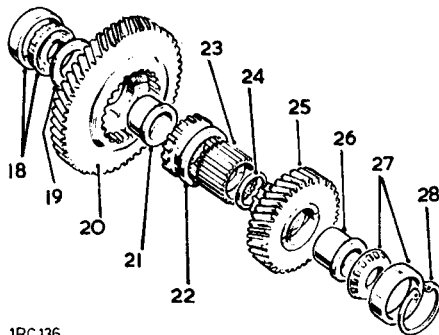

1RC136

- 25 High gear wheel.
- 26 Bush for high gear wheel.
- 27 Bearing for output shaft, front.
- 28 Circlip fixing bearing.
- 29 The steel thrust washer for the high gear wheel and the two locating pegs in the output shaft must be in good condition.
- 30 If necessary, renew the oilite bush in the transfer casing, which carries the transfer selector shaft. This bush is an interference fit in the casing, and must be reamed to 28,16 mm (1.148 in.) after fitting.

Pre-assembly end-float checks, items 31 to 39

- 31 Fit the steel thrust washer and the rear bearing on to the rear of the output shaft.
- 32 Fit the low gear wheel complete with bush on to the output shaft to abut with the steel thrust washer.
- 33 Hold the bush in firm contact with the steel thrust washer and check the end-float of the low gear wheel, which must be 0.05 mm to 0.22 mm (0.002 in. to 0.009 in.).

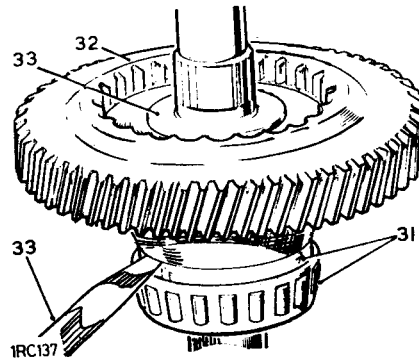

1RC137

- 34 Remove the low gear wheel from the shaft, and replace the centre bush.
- 35 Fit the change speed inner member, and the thrust washer for the high gear wheel.
- 36 Fit the high gear wheel complete with bush.

- 37 Hold the bush for the high gear wheel in firm contact with the thrust washer and check the end-float of the high gear wheel, which must be 0,12 mm to 0,55 mm (0.005 in. to 0.022 in.).
- 38 Excessive end-float on either gear wheel may be rectified by carefully rubbing down the end of the respective bush, using fine emery cloth and a face plate. Insufficient end-float can be rectified by fitting a new bush, followed by a further end-float check and rubbing down as necessary.
- 39 Remove all the components from the shaft except the steel thrust washer and rear bearing inner member, ready to proceed with the final assembly of the transfer box.

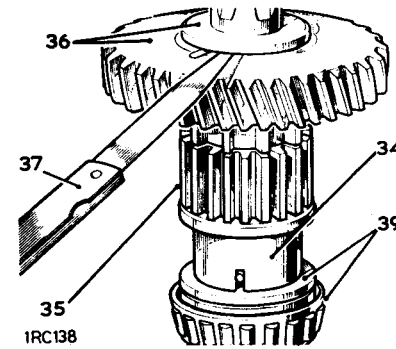

1RC138

Assembling

- 40 Fit the bush to the low gear wheel.

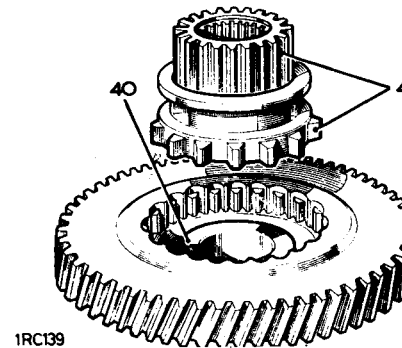

1RC139

- 41 Place the change speed inner and outer members against the thrust side of the bush. The recessed side of the inner member should be towards the bush, and the teeth on the outer member should be in mesh with the internal teeth of the gear wheel.
- 42 Place the high gear wheel, minus its centre bush, in position on the assembly with the dog teeth abutting the change speed outer member.
- 43 Lower the complete assembly into position in the transfer box, with the low gear wheel to the rear.
- 44 Carefully push the output shaft through the assembly and into position, from the rear, ensuring that the low gear wheel bush locates on the peg in the shaft, and that the splines of the change speed inner member are located on the shaft splines.

continued

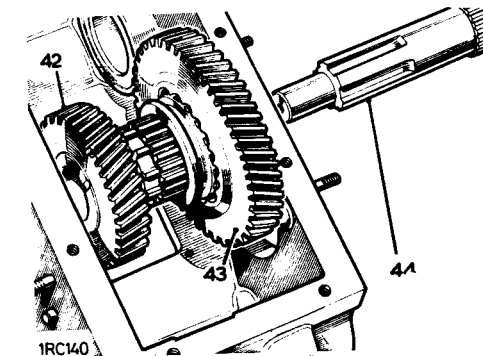

1RC140

(ALL HELICAL GEAR TYPE)

- 45 Slide the thrust washer for the high gear wheel over the front of the shaft and through the centre of the high speed gear, taking care to ensure that the washer slides over the peg and is located in the recess on the gear change inner member.
- 46 Fit the bush through the high gear wheel and locate it also on the peg.

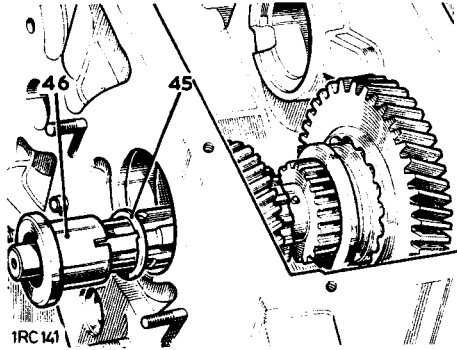

- 47 Turn the casing on its side with the rear face downwards.
- 48 With the output shaft threaded end resting on the bench, drift the front taper roller bearing on to the shaft. Protect the thread against damage and make sure that the gears do not separate while the roller bearing is being fitted otherwise the bushes may become dislodged from the pegs on the shaft.

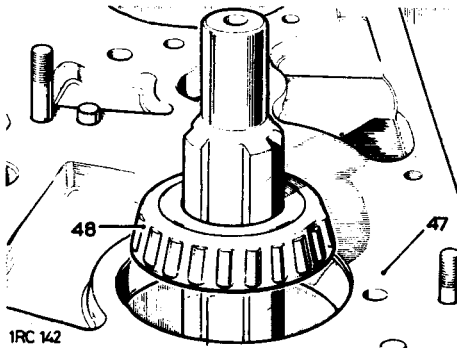

- 49 With the assembly held in the same position, drive the front bearing outer race into the housing.
- 50 Fit the circlip.

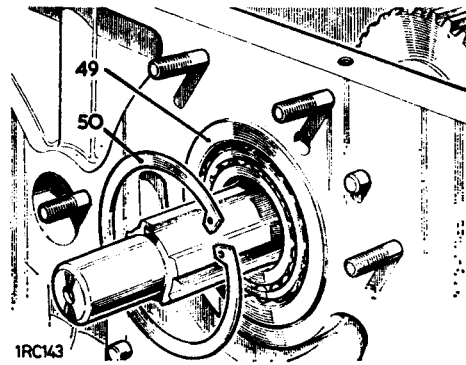

- 51 Fit the rear bearing outer race, do not fit fully in at this stage.
- 52 Using the protection cap 243241 over the threaded end of the output shaft, drive the shaft forward until the front bearing is hard against the circlip.
- 53 Then lightly tap the rear bearing outer race further in to remove all end-float from the output shaft without introducing pre-load.

Setting the output shaft bearing pre-load, items 54 to 61

- 54 Fit the speedometer housing, without any shims, and loosely retain with nuts and spring washers.

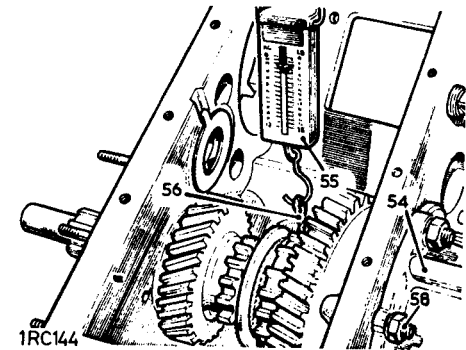

- 55 Measure the rolling resistance of the output shaft, using a nylon cord attached to a spring balance. Coil the cord around the low gear wheel selector groove and note the measurement recorded on the spring balance required to rotate the output shaft after having overcome inertia.
- 56 Ensure that the cord does not slip, giving a false reading.
- 57 Bearing pre-load is correct when a figure of 0,9 kg. to 1,8 kg. (2 lbs to 4 lbs.) is recorded on the spring balance.
- 58 Adjustment is made by tightening the speedometer housing securing nuts, progressively and evenly.
- 59 When the bearing pre-load is correct, ensure that the clearance between the speedometer housing and the transfer box is evenly disposed, using feeler gauges. The measured clearance obtained is equal to the thickness of shims required for subsequent assembly between the speedometer housing and transfer box to maintain correct bearing pre-load.
- 60 Withdraw the spring balance and nylon cord from the low gear wheel, and remove the speedometer housing from the transfer box.

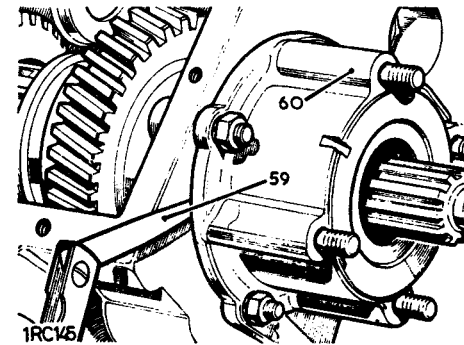

- 61 Using a determined thickness of shims, fit the speedometer drive worm and housing.

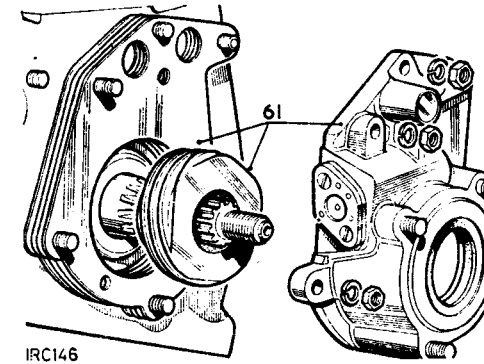
**Determining the intermediate gear end-float, items 62 to 66**

- 62 Place the two thrust washers for the intermediate gear in position in the transfer box and retain with a film of grease. The washers must be fitted with the bronze faces inward and located in the casing by their tabs.
- 63 Locate the intermediate gear, complete with roller bearings, in position in mesh with the high and low gear wheels.

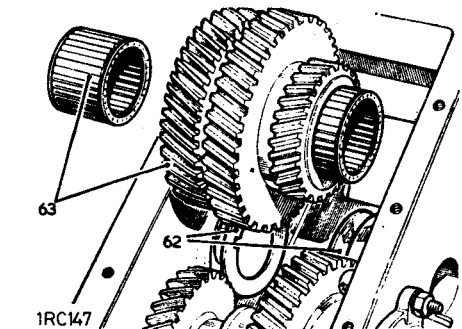

(ALL HELICAL GEAR TYPE)

- 64 Fit the intermediate shaft through the casing, thrust washers and intermediate gear, tapping it lightly home when the spigotted end of the shaft engages its location in the front of the casing. The shaft must be a light tap fit.
- 65 Using feeler gauges, check the end-float of the intermediate gear, this must be 0,10 mm to 0,20 mm (0.004 in. to 0.008 in.).
- 66 Adjustment is made by grinding the steel face of the thrust washers to increase end-float, or by fitting shims, available in 0,25 mm (0.010 in.) thickness, between the thrust washers and the casing to reduce end-float.
- 67 When the intermediate gear end-float is correct, remove the intermediate shaft and gear, and place aside for subsequent assembly after the transfer box has been fitted to the main gearbox.
- 68 Reassemble the rear bearing housing and the output drive flange by reversing the removal procedure.
- 69 Adjust the transfer travel stop after fitting the front output shaft housing to the transfer box, see 37.10.05.
- 70 Refit the transfer gearbox. 37.29.25.

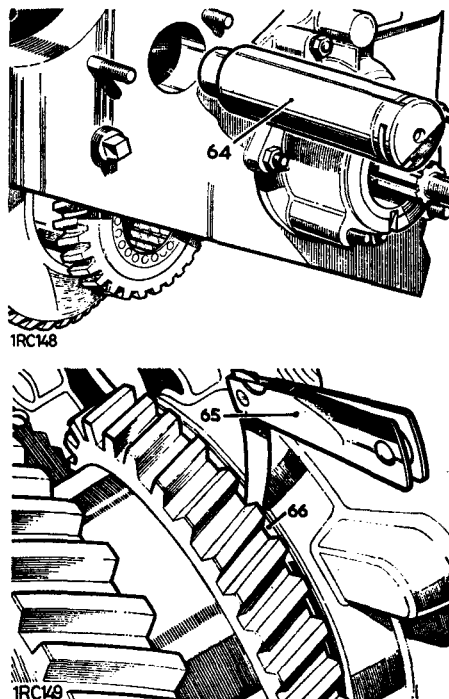

DATA

Bush for transfer selector shaft	29,16 mm (1.148 in.) reamed diameter
End-float of low gear wheel	0,05 to 0,22 mm (0.002 to 0.009 in.)
End-float of high gear wheel	0,12 to 0,55 mm (0.005 to 0.022 in.)
Output shaft bearing pre-load	0,9 to 1,8 kg. (2 to 4 lb.) measured with spring balance cord coiled around the low gear wheel selector groove.
End-float of intermediate gear	0,10 to 0,20 mm (0.004 to 0.008 in.)

TRANSFER GEARBOX (HELICAL AND SPUR GEAR TYPE)

Overhaul 37.29.28

Service tool: 243241, thread protector

Dismantling

General

There are two types of transfer box in use, one with helical and spur gears and the other with all helical gears. The only visible external difference between the two is a selector shaft adjuster fitted to the front output shaft housing on the all helical box only. Identify the gearbox type before proceeding. Because the overhaul instructions for the two types carry the same operation number (37.29.28) but are printed separately, the applicable description is added to the operation title and to each continuing page.

- 1 Remove the transfer gearbox. 37.29.25.
- 2 Remove the front output shaft housing. 37.10.05.
- 3 Remove the speedometer drive housing. 37.25.09.
- 4 Using a mallet, drive the output shaft rearwards.
- 5 Withdraw the rear bearing outer race when released from the casing.

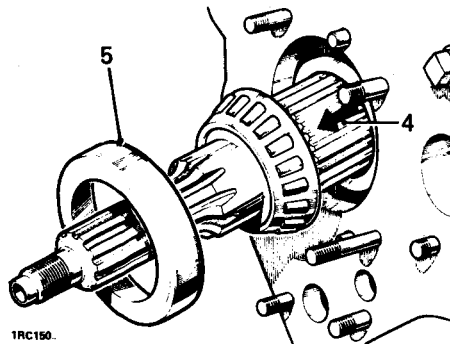

- 6 Fit protection cap 243241, over the threaded end of the output shaft, and drive the shaft forward as far as possible.
- 7 Slide the shaft to the rear and insert a suitable packing piece between the rollers of the front bearing and the outer race.

NOTE: A packing piece can be made from a scrap bearing outer race, with the outer diameter reduced to give clearance in the transfer box and suitably slotted to fit over the shaft.

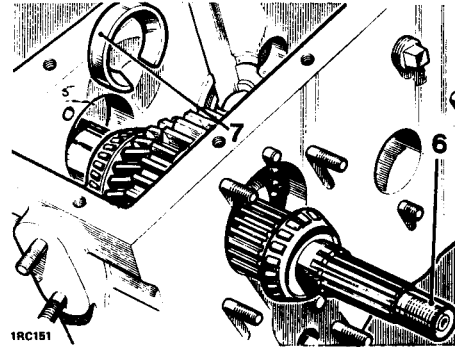

- 8 Remove the circlip retaining the front bearing outer race.
- 9 With the packing piece in position, drive the shaft forward.
- 10 Withdraw the front bearing outer race.

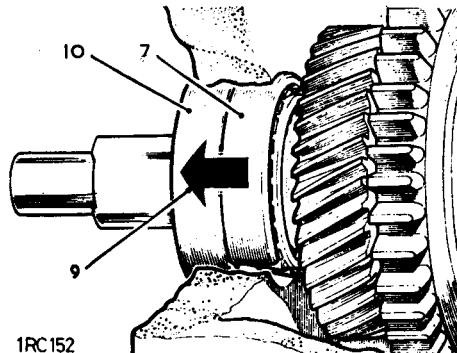

- 11 Place pads of rag in position to protect the transfer box bearing bores during the following operations.

- 12 Using a suitable mild steel bar with a chisel end, drive the front bearing from the output shaft.

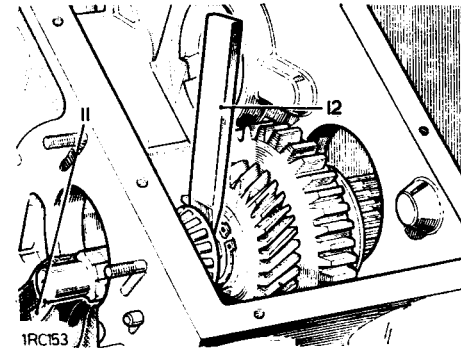

- 13 Remove the circlip and thrust washer from the output shaft.
- 14 Withdraw the shaft through the gears.
- 15 Remove the gears through the bottom of the casing.

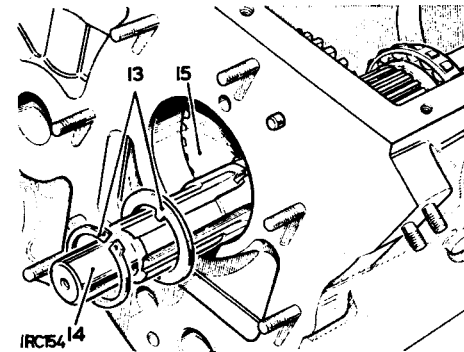

- 16 Retain the protector 243241 on the shaft threads.
- 17 Extract or press the rear bearing from the output shaft.
- 18 As illustrated, the low speed gear may be used as a press block for the removal of the rear bearing.

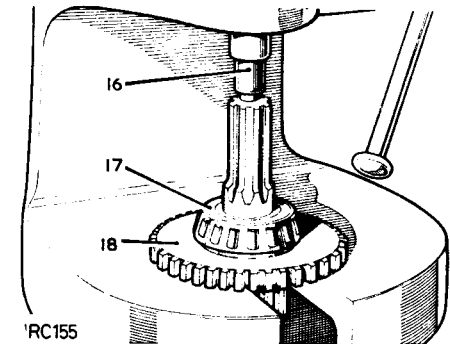

- 19 Remove the circlip, retaining plate and roller bearing from the mainshaft rear bearing housing.

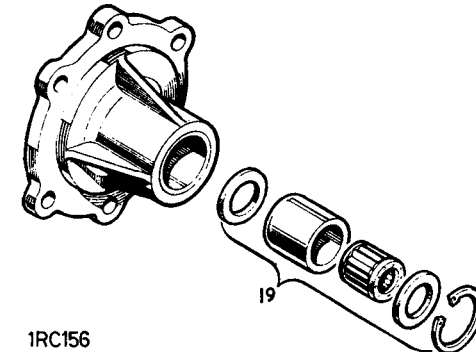

(HELICAL AND SPUR GEAR TYPE)

- 20 Remove the fixings, flange to brake drum.
- 21 Withdraw the coupling flange.
- 22 Prise off the mud shield.
- 23 Remove the retaining circlip from the propeller shaft bolts.
- 24 Withdraw the bolts and retainer plate.

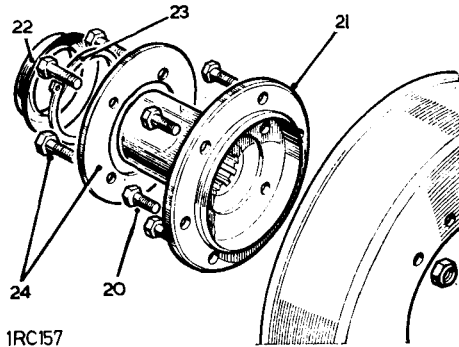

1RC157

Inspecting

- 25 Renew any components which show obvious wear or damage. Check the condition of the shaft splines for the low gear wheel, it is important that the spline corners are not worn. Note that the low gear wheel is a loose fit on the shaft, this allows the gear to tilt in operation, causing the spline edges at the annular groove to bite on the splines of the low speed gear, locking it in position. Examine the sleeve of the output flange for damage which could cause failure of the oil seal.

Pre-assembly check, items 26 to 31

- 26 Fit the high gear wheel on to the output shaft.
- 27 Fit the thrust washer.
- 28 Fit the circlip.
- 29 Place a suitable piece of tube over the shaft and push the circlip towards the gear to produce minimum gear end-float.

- 30 Maintaining this condition, check the end-float between the gear and the shaft, this must be 0,15 mm to 0,20 mm (0.006 in. to 0.008 in.) under these conditions.
- 31 Adjustment of the high gear wheel end-float is made by reducing the thickness of the thrust washer, or fitting a new thrust washer, as required. If fitting a new thrust washer fails to reduce the end-float to the required limits, replace the shaft and/or gear.

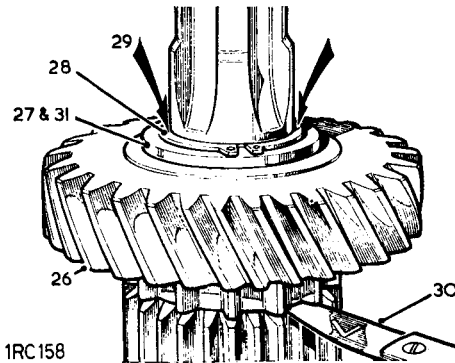

1RC158

Assembling

- 32 Position the high and low gears in the transfer box.
- 33 Fit the output shaft, from the rear of the box, to engage the gears.

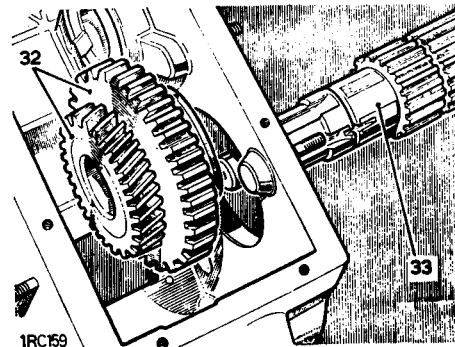

1RC159

- 34 Fit the thrust washer, determined during the pre-assembly check, to the output shaft and secure, using a new circlip.

- 35 Use pads of rag to protect the transfer box bearing bores, and drive the two roller bearings on to the output shaft. Fit the front bearing outer race and secure with a circlip.
- 36 Fit the rear bearing outer race.
- 37 Using the protection cap 243241 over the threaded end of the output shaft, drive the shaft forward until the front bearing is hard against the circlip. Then lightly tap the rear bearing outer race further in to remove all end-float from the output shaft without introducing pre-load.

Setting the output shaft bearing pre-load, items 38 to 44

- 38 Fit the speedometer housing, without any shims, and loosely retain with nuts and spring washers.
- 39 Measure the rolling resistance of the output shaft, using a nylon cord attached to a spring balance. Coil the cord around the low gear wheel selector groove and note the measurement recorded on the spring balance required to rotate the output shaft after having overcome inertia.
- 40 Ensure that the cord does not slip, giving a false reading.
- 41 Bearing pre-load is correct when a figure of 0,9 to 1.8 kg. (2 to 4 lbs.) is recorded on the spring balance. Adjustment is made by tightening the speedometer housing securing nuts, progressively and evenly.

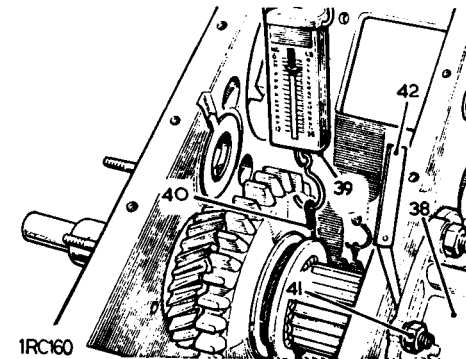

1RC160

- 42 When the bearing pre-load is correct, ensure that the clearance between the speedometer housing and the transfer box is evenly disposed, using feeler gauges. The measured clearance obtained is equal to the thickness of shims required for subsequent assembly between the speedometer housing and transfer box to maintain correct bearing pre-load.
- 43 Withdraw the spring balance and nylon cord from the low gear wheel, and remove the speedometer housing from the transfer box.
- 44 Using the determined thickness of shims, fit the speedometer drive worm and housing.

continued

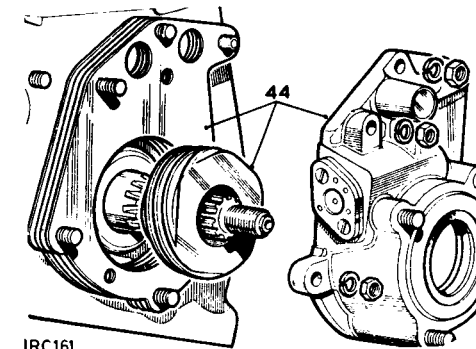

1RC161

(HELICAL AND SPUR GEAR TYPE)

Determining the intermediate gear end-float, items 45 to 49

- 45 Place the two thrust washers for the intermediate gear in position in the transfer box and retain with a film of grease. The washers must be fitted with the bronze faces inward and located in the casing by their tabs.
- 46 Locate the intermediate gear, complete with roller bearings, in position in mesh with the high and low gear wheels.

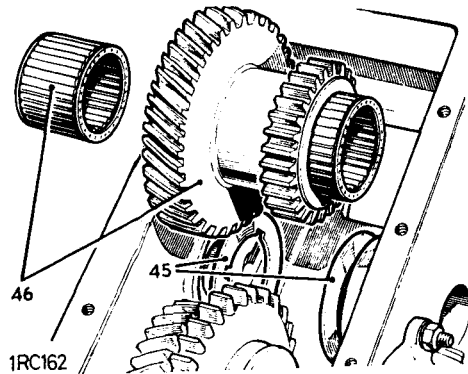

- 47 Fit the intermediate shaft through the casing, thrust washers and intermediate gear, tapping it lightly home when the spigotted end of the shaft engages its location in the front of the casing. The shaft must be a light tap fit.
- 48 Using feeler gauges, check the end-float of the intermediate gear, this must be 0,10 mm to 0,20 mm (0.004 in. to 0.008 in.).

DATA

High gear end-float
 Intermediate gear end-float
 Output shaft bearing pre-load

- 49 Adjustment is made by grinding the steel face of the thrust washers to increase end-float, or by fitting shims, available in 0,25 mm (0.010 in.) thickness, between the thrust washers and the casing to reduce end-float.

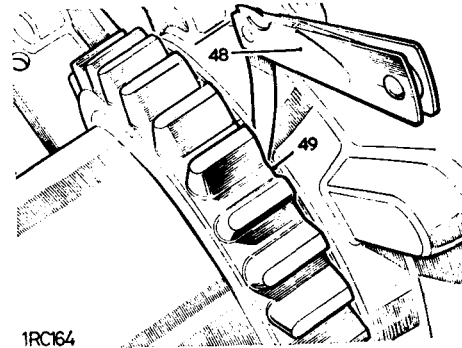

- 50 When the intermediate gear end-float is correct, remove the intermediate shaft and gear, and place aside for subsequent assembly after the transfer box has been fitted to the main gearbox.

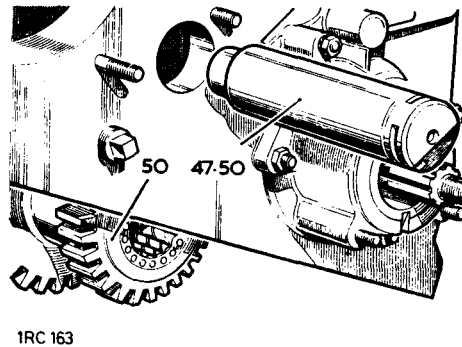

0,15 to 0,20 mm (0.006 in. to 0.008 in.)
 0,10 to 0,20 mm (0.004 in. to 0.008 in.)
 0,9 to 1,8 kg. (2 to 4 lb.) measured with spring balance cord coiled around the low gear-wheel selector groove.

- 51 Re-assemble the rear bearing housing and the output drive flange by reversing the removal procedure.
- 52 Refit the transfer gearbox. 37.29.25.

IMPORTANT NOTE

Main Gearbox

A new layshaft was introduced on Suffix 'C' gearboxes commencing at the following serial numbers:

- 90420785 C
- 95133940 C
- 89503913 C
- 90116000 C

The new layshaft, which has the same part number as its predecessor, can be identified by the reduced length of the step between the rear bearing and back face of the first speed layshaft. The step length was 1,5 mm (0.060 in) and is now 0,45 mm (0.018 in), dimension 'A'.

In addition to the layshaft change, gearboxes with Suffix letter 'D' contain gears manufactured to a process known as Electro-Chemically Machined (E.C.M.). The gears concerned are as follows:

Description	Part No.
Primary pinion and constant gear	RTC 2684
3rd/4th synchro clutch	FRC 2765
1st speed mainshaft gear	FRC 3201
2nd speed mainshaft gear	FRC 2673
3rd speed mainshaft gear	FRC 2720
1st/2nd inner/outer member	RTC 2685
1st/2nd selector shaft	FRC 5897

E.C.M. gears **must not** be fitted with the early type layshaft. Therefore when fitting E.C.M. gears to a Suffix 'C' gearbox, before the above serial numbers, the layshaft must be replaced by the latest type.

Also, when fitting E.C.M. gears to a pre-Suffix 'D' gearbox, the 1st/2nd selector shaft must be changed for latest modified shaft FRC 5897. Whilst the fork is the same, it would be preferable to renew it at the same time. It is important that the fork is assembled to the shaft to dimension 'B' 18,28 mm to 18,16 mm (0.720 in to 0.715 in).

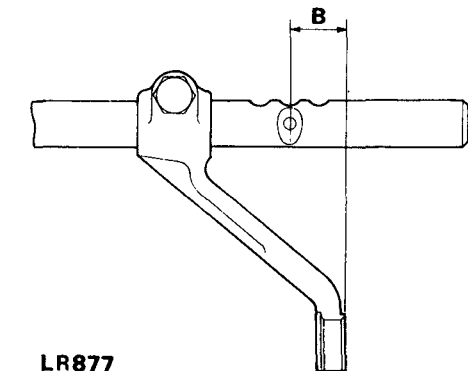
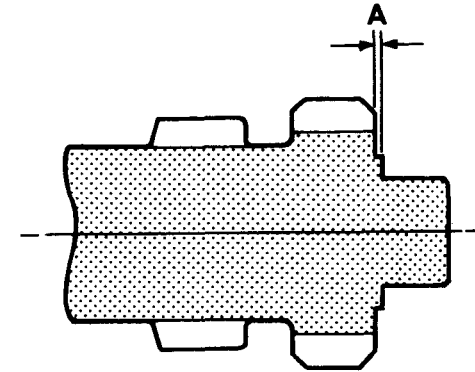

PROPELLER SHAFT

Remove and refit

Front propeller shaft	47.15.02
Rear propeller shaft	47.15.03

Removing

- 1 Disconnect the propeller shaft from the axle and gearbox.
- 2 Withdraw the propeller shaft.

Refitting

- 3 Locate the propeller shaft in position ensuring that the sliding member is fitted towards the front of the vehicle.
- 4 Fit the securing nuts and bolts to the axle and gearbox flanges. Torque 4,2 to 5,2 kgf. m (30 to 38 lbf. ft.)

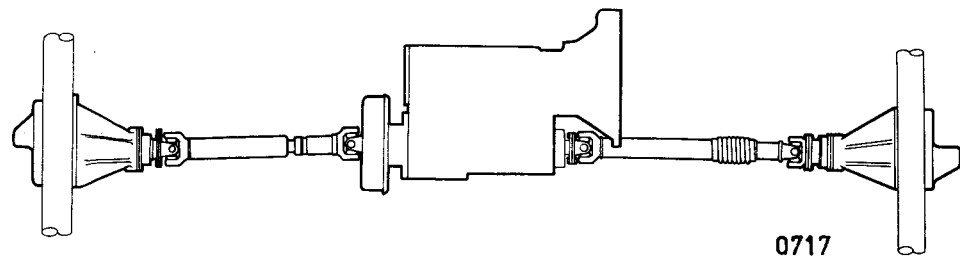

PROPELLER SHAFT

Overhaul

Front propeller shaft	47.15.11
Rear propeller shaft	47.15.12

Dismantling

- 1 Remove the propeller shaft from the vehicle.
- 2 If a gaiter encloses the sliding member release the two securing clips. Slide the gaiter along the shaft to expose the sliding member.
- 3 Note the alignment markings on the sliding member and the propeller shaft.
- 4 Unscrew the dust cap and withdraw the sliding member.
- 5 Clean and examine the splines for wear. Worn splines or excessive backlash will necessitate propeller shaft renewal.
- 6 Remove paint, rust, etc. from the vicinity of the universal joint bearing cups and circlips.
- 7 Remove the circlips, and grease nipple.

continued

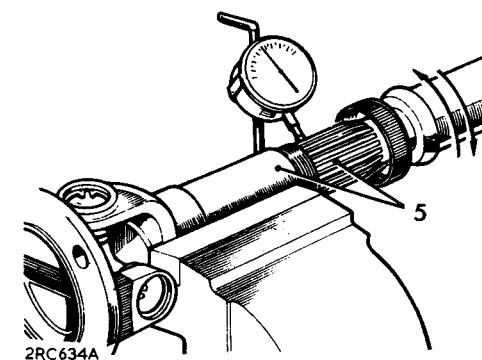
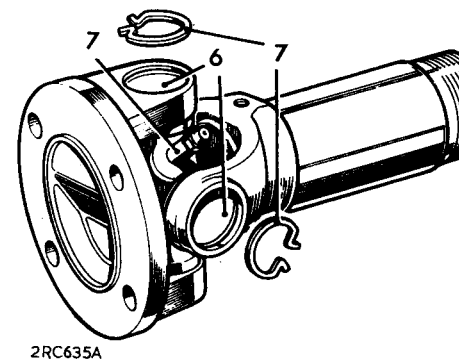
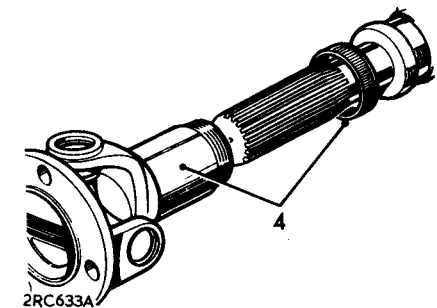
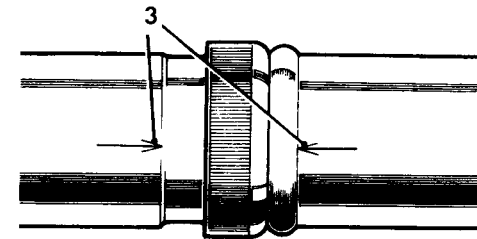

- 8 Tap the yokes to eject the bearing cups.
- 9 Withdraw the bearing cups and spider and discard.
- 10 Repeat instructions 5 to 8 at opposite end of propeller shaft.
- 11 Thoroughly clean the yokes and bearing cup locations.

Assembling

- 12 Remove the bearing cups from the new spider.
- 13 Check that all needle rollers are present and are properly positioned in the bearing cups.
- 14 Ensure bearing cups are one third full of fresh lubricant.
- 15 Enter the new spider complete with seals into the yokes of the sliding member flange. Ensure that the grease nipple hole faces away from the flange.
- 16 Partially insert one bearing cup into a flange yoke and enter the spider trunnion into the bearing cup taking care not to dislodge the needle rollers.
- 17 Insert the opposite bearing cup into the flange yoke. Using a vice, carefully press both cups into place taking care to engage the spider trunnion without dislodging the needle rollers.
- 18 Remove the flange and spider from the vice.
- 19 Using a flat faced adaptor of slightly smaller diameter than the bearing cups press each cup into its respective yoke until they reach the lower land of the circlip grooves. Do not press the bearing cups below this point or damage may be caused to the cups and seals.
- 20 Fit the circlips.
- 21 Engage the spider in the yokes of the sliding member. Fit the bearing cups and circlips as described in instructions 15 to 20.
- 22 Lubricate the sliding member spines and fit the sliding member to the propeller shaft ensuring that the markings on both the sliding member and propeller shaft align.

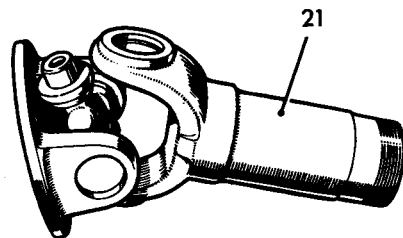
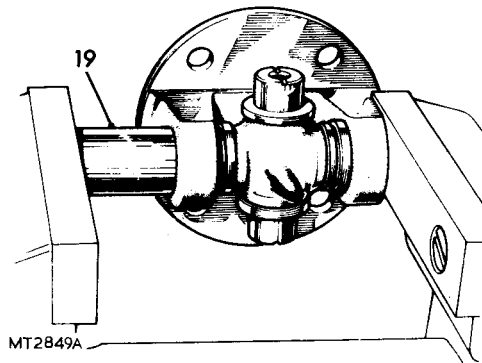
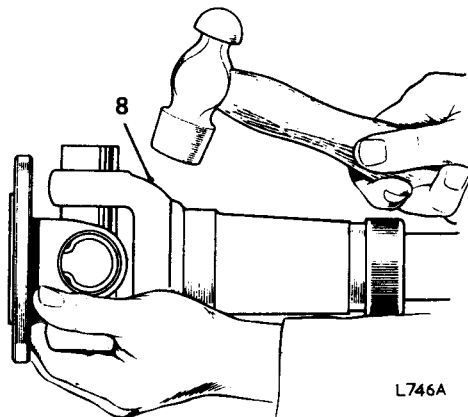

- 23 Fit and tighten the dust cap.
- 24 Fit the grease nipples to the spider and the sliding member and lubricate.
- 25 Slide the gaiter (if fitted) over the sliding member.
- 26 Locate the sliding member in the mid-position of its travel and secure the gaiter clips. Note that the gaiter clips must be positioned at 180° to each other so that they will not influence propeller shaft balance.
- 27 Apply instructions 15 to 20 to the opposite end of the propeller shaft.
- 28 Fit the grease nipple and lubricate.
- 29 Fit the propeller shaft to the vehicle.

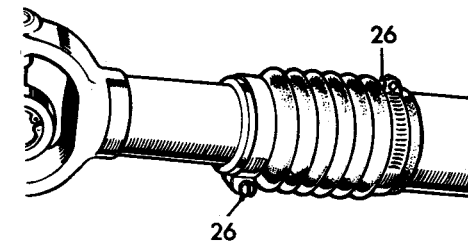

HALF SHAFT (88 models)

Remove and refit 51.10.01

Removing

- 1 Jack up the rear of the vehicle and support securely.
- 2 Remove the road wheels.
- 3 Rotate and slide off the hub cap.
- 4 Remove the split pin and nut securing the half shaft to the driving flange.
- 5 Remove the washer and seal.
- 6 Remove the bolts and washers securing the driving flange to the hub.
- 7 Withdraw the half shaft complete with driving flange and gasket.
- 8 Remove the driving flange from the half shaft.

Refitting

- 9 Reverse instructions 1 to 8.
- 10 Torque: Half shaft nut, 1,4 to 2,0 kgf. m (10 to 15 lbf. ft.)
Drive flange bolt, 4,2 to 5,2 kgf. m (30 to 38 lbf. ft.)

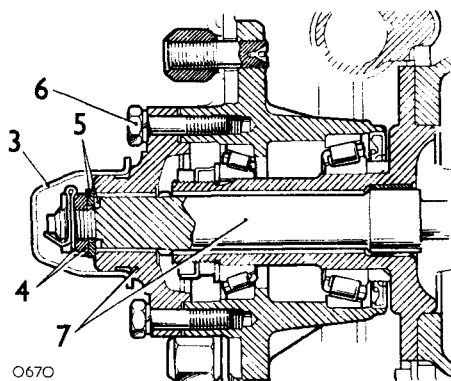

HALF SHAFT (109 models)

Remove and refit 51.10.01

Removing

- 1 Jack up the rear of the vehicle and support securely.
- 2 Remove the road wheel.
- 3 Rotate and slide off the hub cap.
- 4 Remove the bolts and spring washers securing the driving flange to the hub.
- 5 Withdraw the driving flange and half shaft and gasket.
- 6 Remove the circlip from the half shaft.
- 7 Withdraw the driving flange.
- 8 Remove the 'O' ring.

Refitting

- 9 Reverse instructions 1 to 8
- Torque: Drive flange bolts 4,2 to 5,2 kgf. m (30 to 38 lbf. ft.)

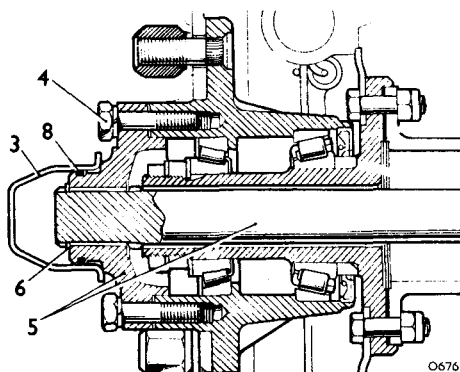

HUB BEARINGS

Remove and refit 51.10.28

Removing

- 1 Jack up the rear of the vehicle and support securely.
- 2 Remove the road wheels.
- 3 Remove the bolts and spring washers securing the driving flange to the hub.
- 4 Withdraw the driving flange and half shaft.
- 5 Remove the brake drum retaining screws and withdraw the brake drum.
- 6 Straighten the tabs on the hub nut lock washer.
- 7 Unscrew and remove the locknut.
- 8 Remove the lock washer, adjusting nut and thrust washer.
- 9 Withdraw the hub complete with bearings and oil seal.
- 10 Remove the outer bearing.
- 11 Remove the oil seal and inner bearing.
- 12 Remove the outer and inner bearing tracks from the hub.
- 13 Thoroughly clean all components.

Refitting

- 14 Fit the outer and inner bearing tracks to the hub.
- 15 Pack the hub with fresh grease.
- 16 Insert the inner bearing in the hub.
- 17 Fit new oil seal to the hub. Lips of seal towards the inner bearing.
- 18 Insert the outer bearing on the hub and slide hub and bearings into position on the stub axle.
- 19 Fit the thrust washer and adjusting nut.
- 20 Tighten the adjusting nut to obtain zero hub end-float.
- 21 Using a dial gauge to check end-float slacken the adjusting nut sufficient to obtain end-float of 0,05 to 0,10 mm (0.002 to 0.004 in.).
- 22 Fit the lock washer and lock nut. Tighten the locknut.
- 23 Bend the lock washer to secure the adjusting nut and lock nut.
- 24 Fit a new driving flange gasket.

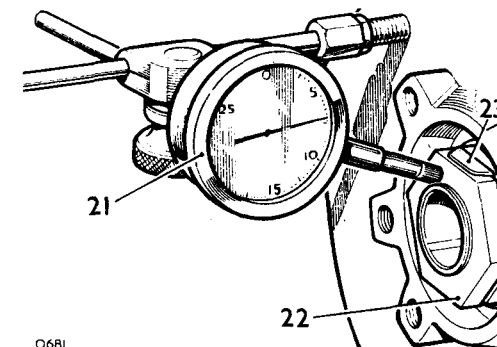
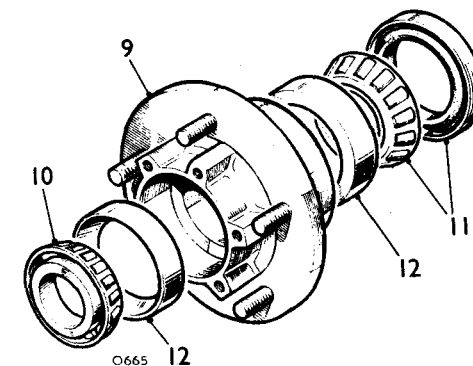
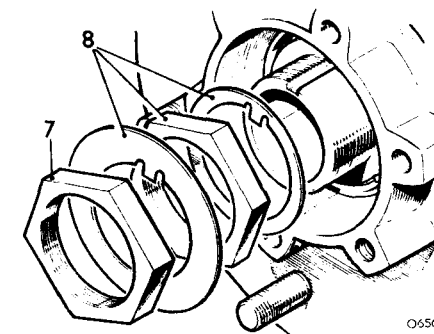

- 25 Fit the half shaft and driving flange assembly.
Torque the bolts to 4,2 to 5,2 kgf. m (30 to 38 lbf. ft.)
- 26 Fit the brake drum and road wheel.
- 27 Lower the vehicle.

DIFFERENTIAL ASSEMBLY (88 models)

Remove and refit 51.15.01

Removing

- 1 Jack up the rear of the vehicle and support on stands.
- 2 Remove the road wheels.
- 3 Drain the oil from the rear axle.
- 4 Remove the bolts and spring washers securing the half shaft flanges to the rear hubs.
- 5 Withdraw the half shafts and drive flanges.

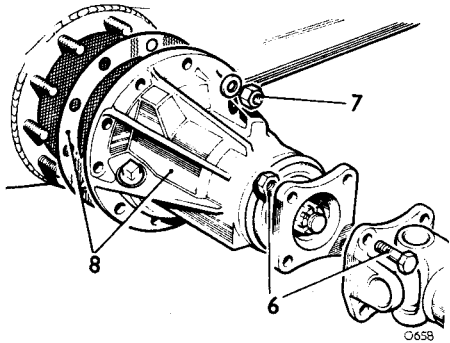

- 6 Disconnect the propeller shaft at the rear axle.
- 7 Remove the nuts and spring washers securing the differential assembly to the axle casing.
- 8 Withdraw the differential assembly and gasket.

Refitting

- 9 Reverse instructions 1 to 8.

DIFFERENTIAL ASSEMBLY (Salisbury type 109 models)

Remove and refit 51.15.01

Overhaul 51.15.07

Service tools:

47	Screw press
18G 131 C	Axle spreader
18G 191	Dial gauge, bracket and base
18G 1122	Screw press
18G 1205	Spanner for drive coupling
S 123 A	Pinion bearing cup remover
18G 47 BK	Pinion bearing cone remover/replacer
18G 47 BL	Differential bearing remover
18G 1122 G	Pinion bearing cup replacer
18G 134 DP	Differential bearing replacer
18G 191 P	Setting gauge for pinion height
18G 131 F	Pegs for axle spreader
RO 1008	Oil seal replacer
530106	Dial gauge bracket

Removing the differential unit

NOTE: All fixing bolts used on the differential assembly and differential cover have metric threads.

- 1 Drain off the differential lubricating oil.
- 2 Remove the rear axle assembly. 51.25.01.
- 3 Remove the hub driving member fixings.

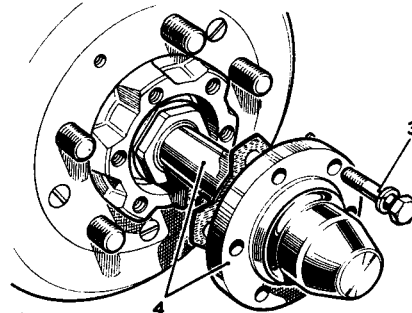

1RC195

- 4 Withdraw the driving member and attached axle shaft sufficient to disengage the differential.
- 5 Repeat 4 for other axle shaft.
- 6 Remove the fixings and support strip at the differential cover and withdraw the cover and joint washer.

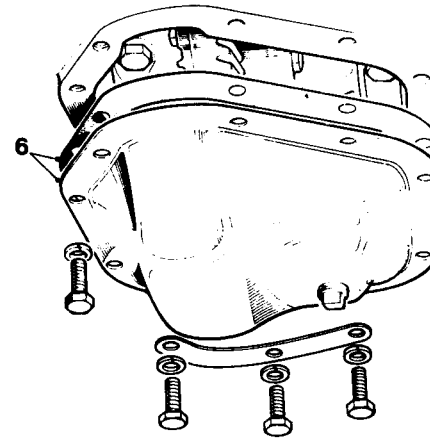

1RC196A

- 7 Note the relationship marking on the bearing caps and axle casing to ensure correct refitting.
- 8 Remove the fixings and withdraw the differential bearing caps.

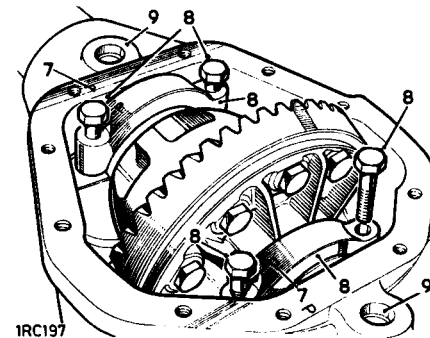

1RC197

- 9 Clean out and examine the spreader tool pegholes provided in the gear casing face; ensure that the holes are free from dirt and burrs and damage.
- 10 Ensure that the turnbuckle adjuster is free to turn.
- 11 Fit the axle spreader to engage the peg holes. Spreader 18G 131 C, Adaptor pegs 18G 131 F.

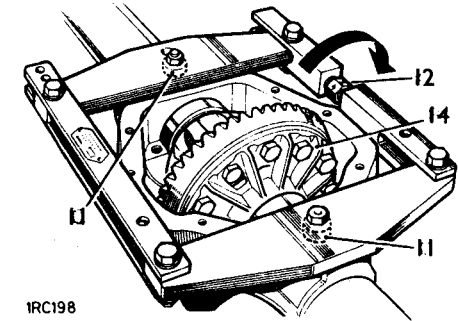

1RC198

- 12 Turn the adjuster until all free play between the spreader and casing is taken up, denoted by the adjuster becoming stiff to turn, using a spanner on the adjuster.
- 13 Check that the side members of the spreader are clear of the casing.
- 14 Stretch the casing, rotating the adjuster by one flat at a time, until the differential assembly can be levered out. Do not lever against the spreader; use suitable packing under the levers to avoid damage to the casing.

CAUTION: To prevent permanent damage to the gear carrier case, it must not be over-stretched. Each flat on the turnbuckle is numbered to enable a check to be made on the amount turned. The maximum stretch permitted is 0,30 mm (0.012 in), equivalent to three flats.

- 15 Ease off the adjuster and remove the spreader.

continued

Dismantling the differential unit

16 Add alignment marks between the crown wheel and the differential case for reassembly purposes, then remove the fixings and withdraw the crown wheel.

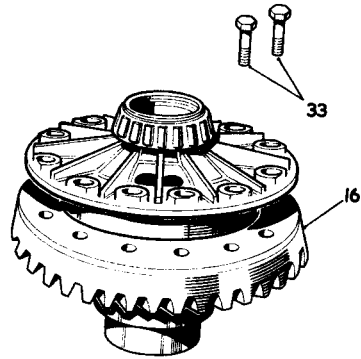

1RC484

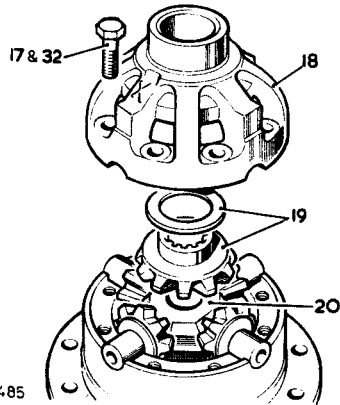

1RC485

17 Note the alignment markings on the two differential casings to ensure correct refitting, then remove the fixings.
18 Lift off the upper case.

19 Withdraw the upper differential wheel and thrust washer.
20 Lift out the cross-shaft and pinions.

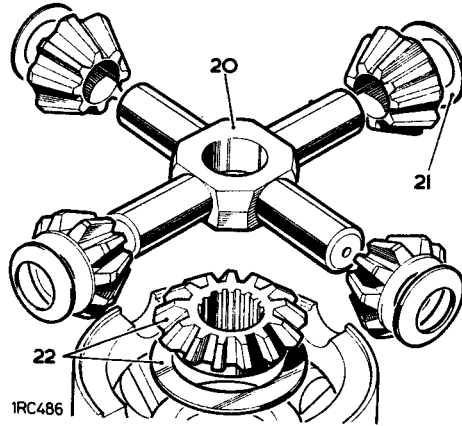

1RC486

21 Withdraw the dished thrust washers.
22 Withdraw the lower differential wheel and thrust washer.

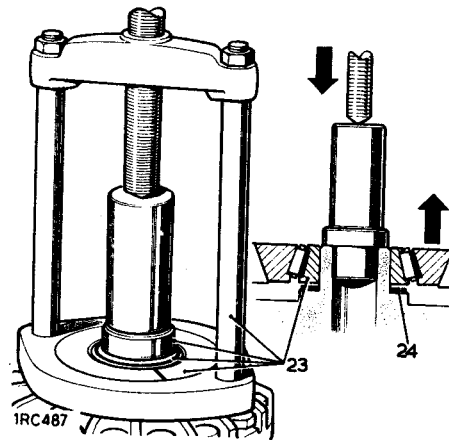

1RC487

23 Remove the differential bearing cones. Remove 18G 47 BL details 1 and 2, Press 47.
24 Withdraw the shim washers fitted between the bearing cones and the differential casings.

Removing the final drive pinion

25 Prevent the coupling flange from rotating and remove the flange locknut and plain washer. Spanner 18G 1205.
26 Support the drive pinion and remove the coupling flange by tapping with a hide hammer.

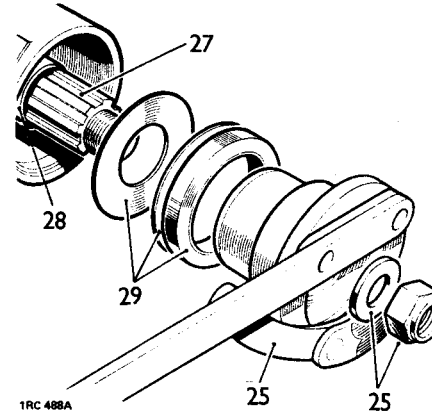

1RC488A

27 Withdraw the drive pinion together with the inner bearing cone.
28 Withdraw and discard the collapsible bearing spacer.
29 Withdraw the oil seal, gasket and oil thrower.
30 Withdraw the outer bearing cone.
31 Extract the pinion inner bearing cup and shim washers from the casing. Note the shim washer thickness. Remove S 123 A.

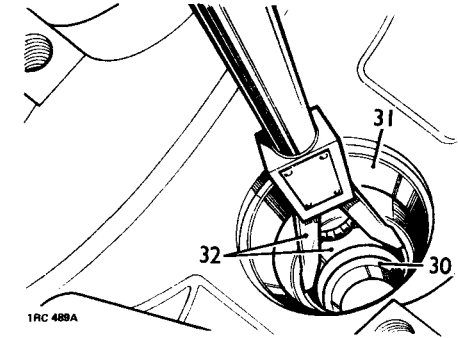

1RC488A

32 Extract the pinion outer bearing cup from the casing. Remove S 123 A.
33 Remove the inner bearing cone from the pinion. Remove 18G 47 BK and Press 47.

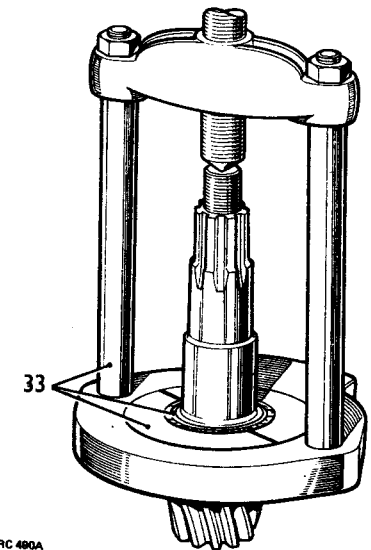

1RC489A

continued

Inspecting

- 34 Examine all components for obvious wear or damage.
- 35 The bearing cones must be a press fit on their locations, except the drive pinion flange and bearing which is a slide fit.
- 36 The crown wheel and pinion are supplied as a matched pair and must not be interchanged separately.
A new crown wheel and pinion matched pair may be fitted to an original gear carrier casing if sound. The original crown wheel and pinion, if sound, may be fitted into a replacement casing.
- 37 The two parts of the differential unit casing are matched and must not be replaced separately.
- 38 Discard and renew all thrust washers.
- 39 Differential housings with worn thrust washer seatings must be replaced as a pair.
- 40 Examine the differential case to crown wheel joint face for burrs and damage which could lead to crown wheel run-out when fitted.

Reassembling**Assembling the differential unit**

- 41 Reverse the items 17 to 22 aligning the marks on the differential casings. Casings fixings torque load is 9,1 to 10,4 kgf m (66 to 75 lbf ft). The fixings tightening should be carried out at opposite sides of the casings and not by following the diameter. Use Loctite 'Studlock' grade on the fixing bolt threads.

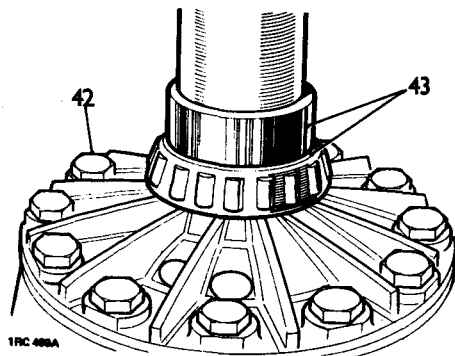

- 42 Fit the crown wheel to the differential casing. Fixings torque is 15,3 to 17,3 kgf/m (111 to 125 lbf ft). Use Loctite 'Studlock' grade CVX on the fixing bolt threads.
- 43 Press on the differential roller bearing cones less shim washers, using 18G 134 DP, and leave to one side until required for instruction 87.
- 44 Fit the bearing cups to the differential.
- 45 Fit the differential unit and bearings to the gear carrier casing, and rotate unit to centralize the bearings. Do not fit the bearing caps.
- 46 Position a suitable dial gauge indicator on the casing with the stylus registering on the back face of the crown wheel.

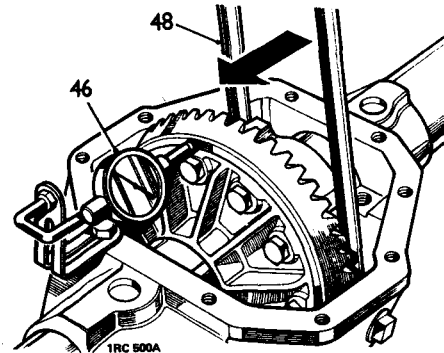

- 47 Rotate the differential and check the total indicated run-out on the crown wheel back face. This must not exceed 0,05 mm (0.002 in). If run-out is excessive, check the mating faces for dirt and damage; if necessary, select a new radial position for the crown wheel. When satisfactory, continue with the following check.

Differential bearing adjustment

- 48 Insert two levers between the casing and the differential unit at one side.

- 49 Move the differential unit fully to one side of the casing; do not tilt the unit.
- 50 Rotate the differential unit to settle the bearings, continue to lever the differential to the side, then zero the dial gauge indicator.
- 51 Lever the assembly fully to the other side of the casing, rotate the unit to settle the bearings, then note the total indicator reading.
- 52 Add 0,127 mm (0.005 in), for bearing pre-load, to the total noted in the preceding item. The sum is then equal to the nominal value of shims required for the differential bearings.
Shims are available in the range 0,07 mm (0.003 in), 0,12 mm (0.005 in), 0,25 mm (0.010 in) and 0,76 mm (0.030 in). Select the total value of shims required.
- 53 Remove the differential unit and bearings and place aside. Do not fit the shim washers until the subsequent 'Differential backlash' checks have been made, items 87 to 93.

Fitting drive pinion

- 54 Select shim washers of the same thickness value as those removed from under the pinion inner cup, item 31, and place ready for fitting.

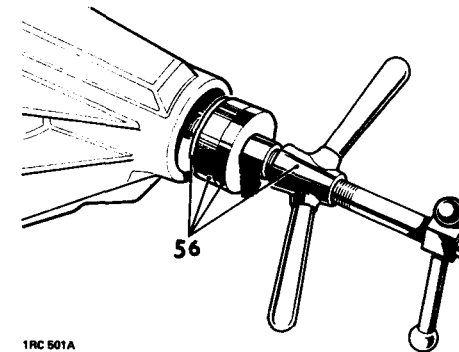

- 55 Position the outer bearing replacer 18G 1122 G detail 2, and the outer bearing cup on the press tool 18G 1122.
- 56 Locate the assembly into the pinion housing nose.

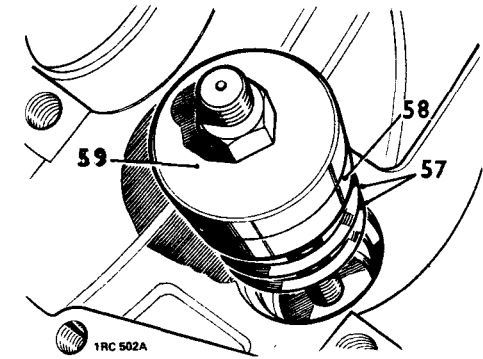

- 57 Place the selected shim washers on to the inner bearing cup seating.
- 58 Position the inner bearing cup in the casing.
- 59 Position the inner bearing replacer 18G 1122 G detail 1, onto 18G 1122 and secure with the fixing nut.
- 60 Hold still the centre screw and turn the butterfly lever to draw in the bearing cups.

continued

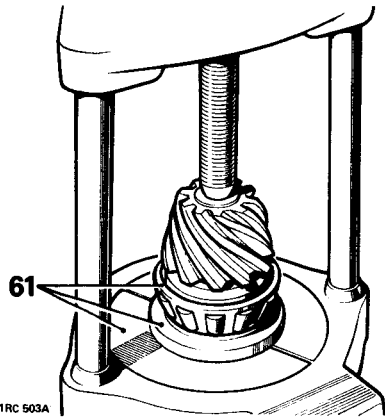

1RC 503A

- 61 Press the inner bearing cone onto the drive pinion. 18G 47 BK, details 1 and 2 and 47.
- 62 Position the pinion and bearing in the casing; omit the collapsible spacer at this stage.
- 63 Fit the outer bearing cone onto the pinion.
- 64 Fit the coupling flange and plain washer and loosely fit the flange nut.
- 65 Tighten the coupling flange locknut sufficient to remove end-float from the pinion.
- 66 Rotate the pinion to settle the bearings and slowly tighten the flange locknut. Whilst using a spring balance to obtain a torque resistance of 9,25 to 13,8 kgf cm (8 to 12 lbf in) to rotate the pinion.

Drive pinion markings

- 67 Check that the serial number marked on the pinion end face matches that marked on the crown wheel.
- 68 The markings on the end face adjacent to the serial number are of no significance during servicing.

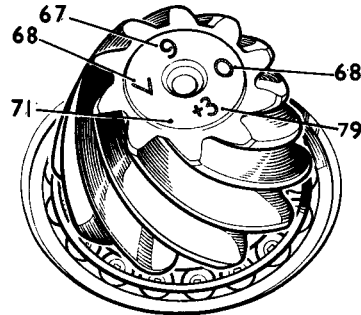

1RC 199A

- 69 The figure marked on the end face opposite to the serial number indicates, in thousandths of an inch, the deviation from nominal required to correctly set the pinion. A pinion marked plus (+) must be set below nominal, a minus (-) pinion must be set above nominal. An unmarked pinion must be set at nominal.

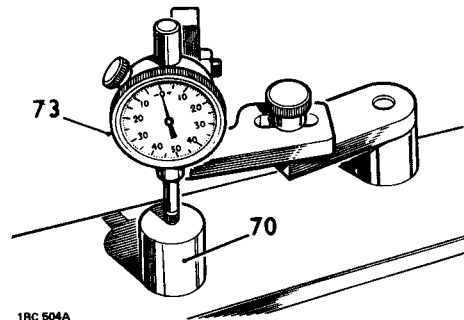

1RC 504A

- 70 The nominal setting dimension is represented by the setting gauge block 18G 191 P, which is referenced from the pinion end face to the bottom radius of the differential bearing bore.

Drive pinion adjustment

- 71 Ensure that the pinion end face is free of raised burrs around the etched markings.
- 72 Remove the keep disc from the magnetized base of dial gauge tool 18G 191.
- 73 Place the dial gauge and setting gauge 18G 191 P on a flat surface and zero the dial gauge stylus on to the setting gauge 18G 191 P.
- 74 Position the dial gauge centrally on the pinion end face with the stylus registering on the lowest point on one differential bearing bore. Note the dial gauge deviation from the zeroed setting.
- 75 Repeat on the other bearing bore. Add together the readings, then halve the sum to obtain the mean reading. Note whether the stylus has moved up or down from the zeroed setting.

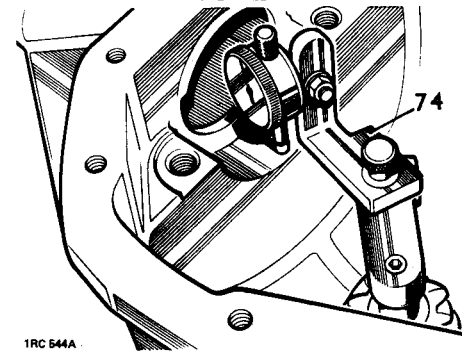

1RC 544A

Example 1

Reading obtained L.H. side	+ 0.006
Reading obtained R.H. side	- 0.003
Add + 0.006	
- 0.003	
<hr/>	
= + 0.003	

Divide by 2 = $\frac{+ 0.003}{2} = + 0.0015$ in

Therefore **subtract** 0.0015 in from the shim thickness behind the pinion inner bearing track.

Example 2

Reading obtained L.H. side	+ 0.006
Reading obtained R.H. side	- 0.008
Add + 0.006 in	
- 0.008 in	
<hr/>	
= - 0.002 in	

Divide by 2 = $\frac{- 0.002}{2} = + 0.001$ in

- 76 a. Where the stylus has moved down, the amount is equivalent to the thickness of shims that must be removed from under the pinion inner cup to bring the pinion down to the nominal position.
- b. Where the stylus has moved up, the amount is equivalent to the additional thickness of shims required to bring the pinion up to the nominal position.

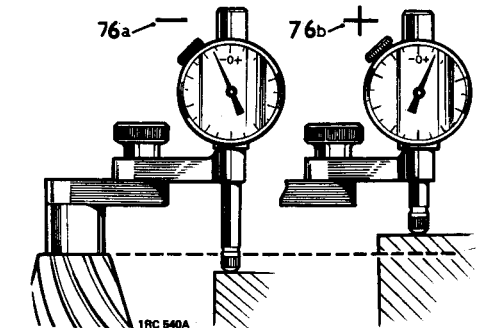

1RC 540A

continued

77 Before adjusting the shim thickness, check the pinion face marking and if it has a plus (+) figure, subtract that amount in thousands of inch from the shim thickness figure obtained in the previous item. Alternatively if the pinion has a minus (-) figure, add the amount to the shim thickness figure.

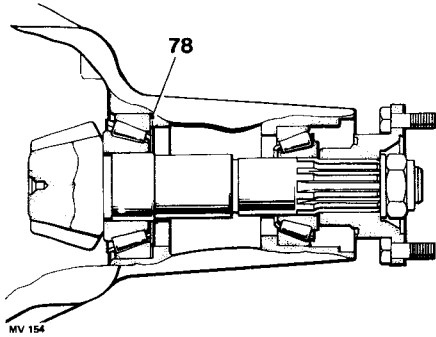

78 Adjust the shim thickness under the pinion inner cup as necessary, by the amount determined in items 76 and 77.
 79 Recheck the pinion height setting 73 to 75. If the setting is correct, the mean reading on the dial gauge will agree with the figure marked on the pinion end face. For example, with an end face marking of +3, the dial gauge reading should indicate that the pinion is 0.003 in below nominal.

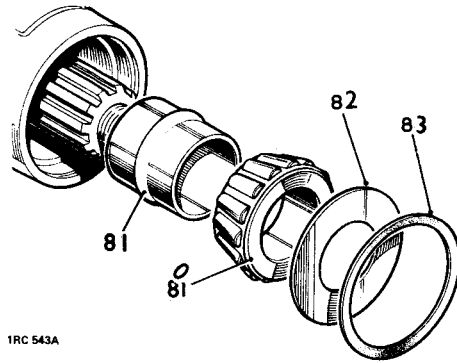

1RC 543A

80 When the pinion setting is satisfactory, temporarily remove the pinion outer bearing cone.
 81 Fit a new collapsible bearing spacer, flared end outward, to the drive pinion and refit the outer bearing cone.
 82. Fit the pinion oil slinger.
 83 Fit the oil seal gasket.
 84 Fit the pinion oil seal, lipped side first, using general purpose grease or, where available, a molybdenum disulphide based grease on the seal lip, using RO 1008 to drift in the seal.
 85 Fit the coupling flange and plain washer and loosely fit a new flange nut. Secure 18G 1205 to the coupling flange, using slave fixings.

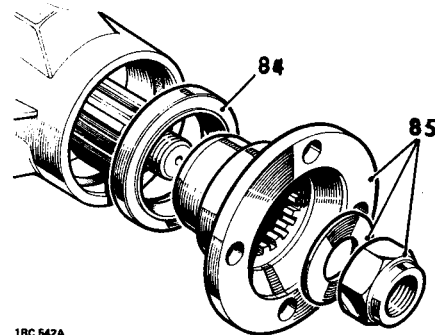

1RC 542A

86 Alternately tighten the flange nut and check the drive pinion resistance to rotation until the following figures are achieved, as applicable:
 a. Assemblies re-using original pinion bearings: 17,3 to 34,5 kgf cm (15 to 30 lbf in).
 b. Assemblies with new pinion bearings: 34,5 to 46,0 kgf cm (30 to 40 lbf in).

NOTE: A torque load of 34,5 kgf cm (250 lbf ft) approximately is required on the coupling flange nut to commence collapsing the bearing spacer. Thereafter, torque resistance build-up is rapid, therefore check frequently, using a spring balance, to ensure the correct figures are not exceeded, otherwise a new collapsible bearing spacer will be required.

Differential backlash checks

87 Pick up the differential unit as left after instruction 43.
 88 Fit the differential unit and lever the unit away from the drive pinion until the opposite bearing cup is seated against the housing. Do not tilt the unit.
 89 Install a dial gauge on the casing with its stylus resting on the back face of the crown wheel. Zero the gauge.

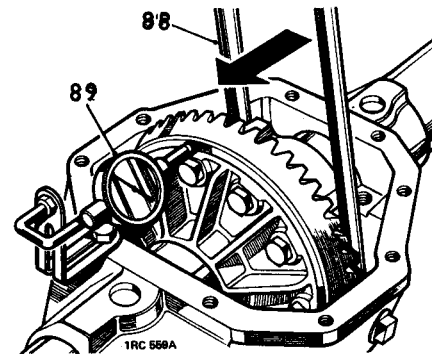

1RC 566A

90 Lever the differential unit to engage the crown wheel teeth in full mesh with the drive pinion teeth. Do not tilt the unit.
 91 Note the total reading obtained on the dial gauge.
 92 From this figure subtract 0,25 mm (0.010 in) to obtain the correct crown wheel backlash when fitted. The result indicates the value of shimming to be fitted between the differential case and the bearing cone at the crown wheel side of the differential.
 93 Fit the shim value determined in 92, taking the shims from the pack previously determined during 'Differential bearing adjustment' checks, items 48 to 53. 18G 47 BL details 1 and 2, Press 47. 18G 134 DP.
 94 Fit the remaining shims from item 92 to the opposite side of the differential. 18G 47 BL details 1 and 2, press 47. 18G 134 DP.
 95 Fit the differential unit with shims and bearings to the axle casing, using the axle spreader 18G 131 C with pegs 18G 131 F.
 96 Remove the axle spreader.
 97 Fit the bearing caps in their correct position, referring to the relationship markings on the caps and on the axle casing.
 98 Tighten the bearing caps fixings to 12,9 to 14,5 kg m (93 to 105 lb ft).
 99 Mount a dial gauge on the axle casing with the stylus resting on a crown wheel tooth.

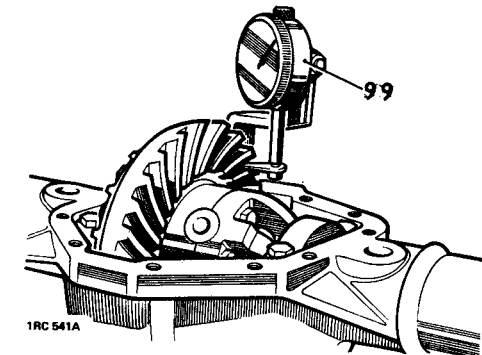

1RC 541A

continued

- 100 Prevent the drive pinion from rotating and check the crown wheel backlash which must be 0,15 to 0,27 mm (0.006 to 0.011 in). If the backlash is not within the specified limits, repeat the differential backlash checks, 87 to 93, looking for possible errors.
- 101 Fit the differential cover and new gasket, coating both sides of the gasket with Hylo-mar PL 32M or an equivalent non-setting sealant.
Torque load for fixings is 2,8 to 3,5 kgf m (20 to 25 lbf ft).
- 102 Reverse 3 to 5. Coat the threads of the hub driving member bolts with Loctite Stud-lock grade CVX and fit and tighten the bolts evenly. Torque: 10,0 kgf m (73 lbf ft).
- 103 Fit the rear axle assembly. 51.25.01.
- 104 Replenish the differential lubricating oil. After the initial axle run, check the oil level and replenish as necessary to the filler/level plug hole.

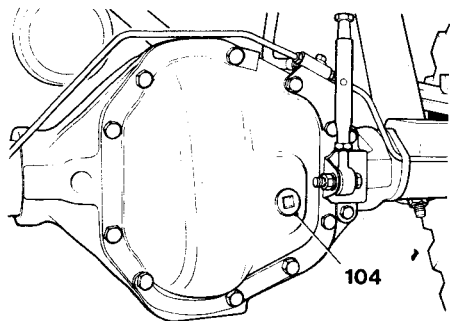

IRC 581A

DATA

Crown wheel backlash	0,15 to 0,27 mm (0.006 to 0.011 in)
Differential bearings pre-load	0,127 mm (0.005 in)
Pinion height setting	Set using gauge 18G 191 P Gauge length 30,912 mm (1.2177 in)

Torque resistance initial setting figures

Torque to turn drive pinion and new pinion bearings	34,5 to 46 kgf cm (30 to 40 lb in)
Torque to turn drive pinion re-using the original bearings	17,3 to 34,5 kgf cm (15 to 30 lb in)

- 105 Where major running parts have been replaced during servicing, it is a recommended practice to allow the axle assembly to 'run in' by avoiding, where possible, heavy loads and high speeds during initial running.

PINION OIL SEAL (ROVER TYPE – 88 MODELS)

Remove and refit 51.20.01

Service tool: 18G 1205 Flange holder.

Removing

- 1 Disconnect the propeller shaft at the rear axle.
- 2 Remove the split pin, nut and washer securing the pinion flange.
- 3 Withdraw the pinion flange.
- 4 Remove the oil seal.

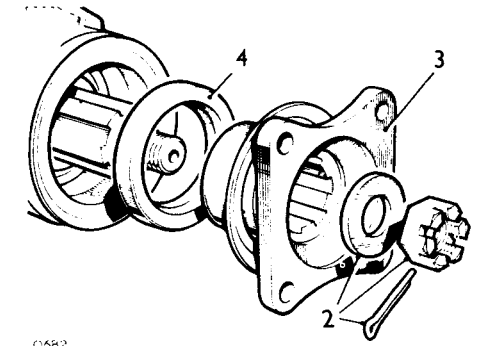

O662

Refitting

- 5 Lubricate the lips of the new seal, smear the outer periphery with jointing compound and reverse instructions 1 to 4.

PINION OIL SEAL (SALISBURY TYPE – 109 MODELS)

Remove and refit 51.20.01

Service tool: 18G 1205. Flange holder.
RO 1008. Oil seal replacer.

Removing

- 1 Disconnect the propeller shaft at the rear axle.
- 2 Carefully mark the relationship of the differential pinion shaft, the flange nut and the flange. This is important to ensure reassembly in original locations to maintain the loading of the collapsible spacer.
- 3 Remove the flange nut and washer and withdraw the flange.
- 4 Remove the pinion oil seal and gasket. Discard and renew.

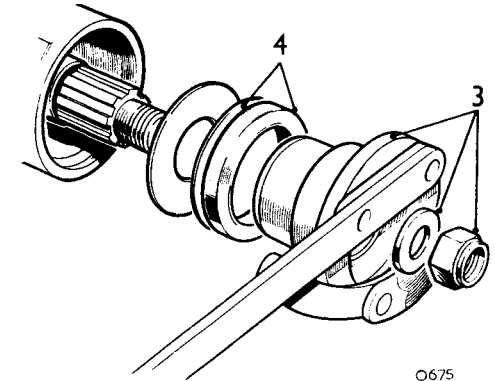

O675

Refitting

- 5 Lubricate the lips of the new seal and install using tool RO 1008. Note the pinion shaft nut must not be tightened beyond the original alignment marks (Instruction 2).
- 6 Fit the flange, washer and nut. Ensure that the marks made on the pinion shaft, flange and nut align. Do not tighten the flange nut beyond its original location.

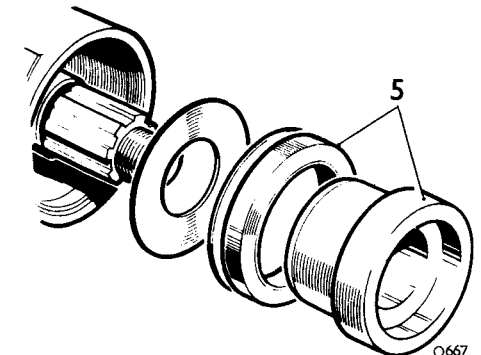

O667

HUB OIL SEAL

Remove and refit 51.20.17

As operation 51.10.28 instructions 1 to 11.

REAR AXLE ASSEMBLY

Remove and refit 51.25.01

Removing

- 1 Slacken the rear road wheel nuts.
- 2 Raise rear of vehicle and support the chassis securely on stands.
- 3 Remove the rear road wheels.
- 4 Disconnect the rear propeller shaft from the rear axle.
- 5 Raise the axle as required to release the axle check straps of all tension. Release one end of the check straps from the chassis brackets.
- 6 **88 inch chassis.** Disconnect the lower end of the shock absorbers from the road spring bottom plates.

109 inch chassis. Disconnect the upper end of the shock absorbers from the chassis.

- 7 Slacken all rear shackle bolts.
- 8 Lower the axle and allow its weight to be supported on the road springs.
- 9 Remove the 'U' bolts and spring bottom plates.
- 10 Disconnect the brake pipe union from the rear brake hose.
- 11 Release the brake hose from the chassis.
- 12 Seal the disconnected brake pipe and the brake hose to prevent entry of foreign matter and loss of fluid.
- 13 Take the weight of the axle on the jack and with an assistant to steady the axle remove the shackle bolts from the rear of the springs. Lower the springs to the ground.
- 14 Withdraw the axle clear of the vehicle.
- 15 **109 inch chassis.** Disconnect the lower end of the shock absorbers from the axle.

Refitting

- 16 **109 inch chassis.** Fit the lower end of the shock absorbers to the spring bottom plate.
- 17 Using a jack and an assistant locate the axle in its approximate position under the vehicle.
- 18 Raise both rear springs and fit the rear shacklebolts and nuts. **DO NOT** tighten the shackle bolts, front or rear, at this stage.
- 19 Lower the axle on top of the road springs ensuring that the spring centre bolts properly engage the axle.
- 20 Fit the 'U' bolts and spring bottom plates. Evenly tighten the 'U' bolt nuts to 10,4 kgf m (75 lbf ft).
- 21 **88 inch chassis.** Fit the lower end of the shock absorbers to the spring bottom plates.
109 inch chassis. Fit the upper end of the shock absorbers to the chassis.

- 22 Fit the brake hose to the chassis ensuring it is not twisted in the process.
- 23 Connect the brake pipe to the brake hose.
- 24 Secure the end of the check straps to the chassis brackets.
- 25 Connect the rear propeller shaft to the axle.
- 26 Adjust the rear brakes as necessary.
- 27 Bleed the brakes. 70.25.02.
- 28 Fit the road wheels.
- 29 Remove the chassis stands and lower the vehicle to the ground.
- 30 Tighten all rear shackle bolts. Refer 64.20.01.
- 31 Check axle oil level and top up as required.

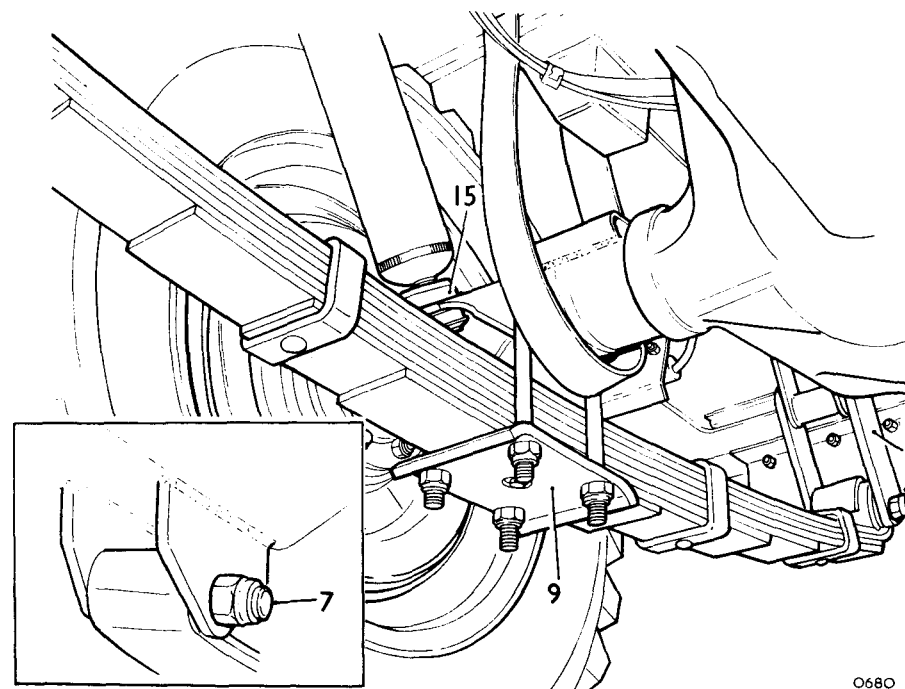
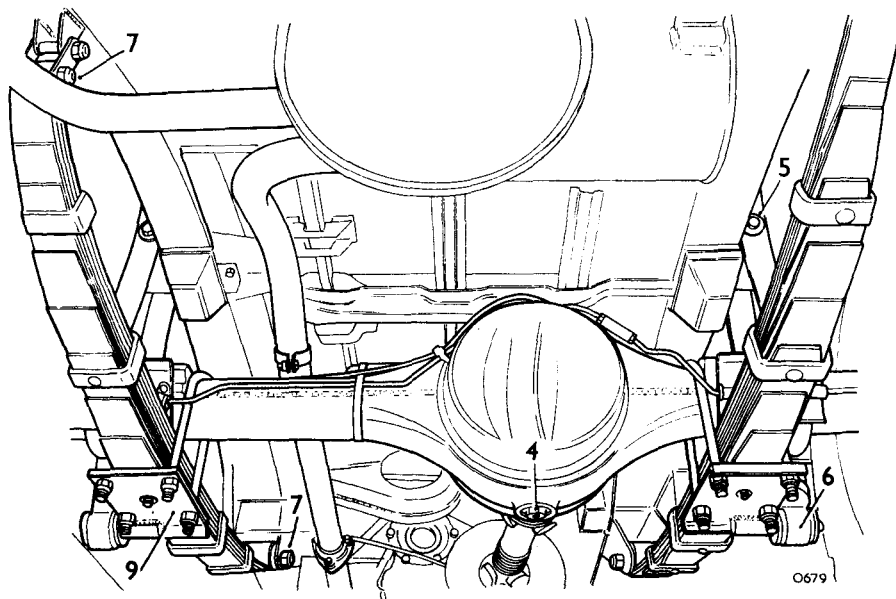

DIFFERENTIAL ASSEMBLY

Remove and refit 54.10.01

Service tool: 601763 Ball joint extractor

Removing

- 1 Remove the half shafts and swivel axles. 54.20.01.
- 2 Drain the differential housing.
- 3 Disconnect the front propeller shaft at the front axle.
- 4 Remove the nuts and spring washers securing the differential to the axle.
- 5 Withdraw the differential assembly and gasket.

Refitting

- 6 Ensure that the mating faces of the differential flange and axle casing are clean. Renew the gasket.
- 7 Reverse instructions 1 to 5.
- 8 Bleed the brakes.

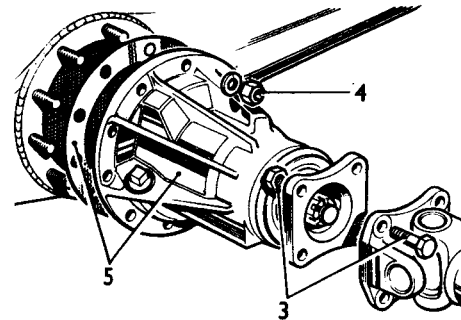

2RC269 A

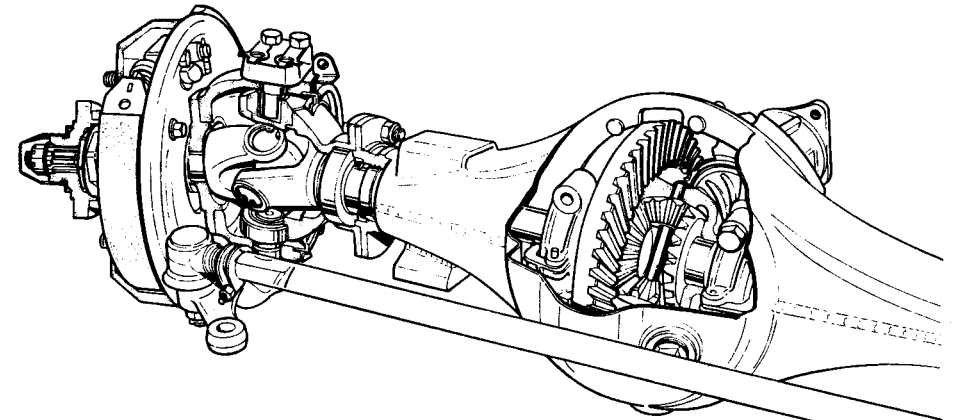

0715

DIFFERENTIAL ASSEMBLY

Overhaul 54.10.07

Service tools:

Press 47

Pinion height gauge. 605004.

Pinion head bearing remover. 18G 47 BK.

Pinion bearing track remover/replacer. 262757, 262757/1.

Spanner bearing nuts. 530105.

Dial gauge. 18G 191.

Flange holder. 18G 1205.

Dismantling

It is essential that differential components are marked in their original positions and relative to other components so that, if refitted, their initial setting is maintained. Note that the bearing caps must not be interchanged.

- 1 Remove the differential assembly from the axle. 54.10.01.
- 2 Drift out the roll pin securing the bearing nut locking fingers to the bearing caps. Remove the locking fingers.
- 3 Slacken the bearing cap bolts.
- 4 Remove the bearing adjusting nuts.
- 5 Remove the bearing cap bolts and bearing caps.

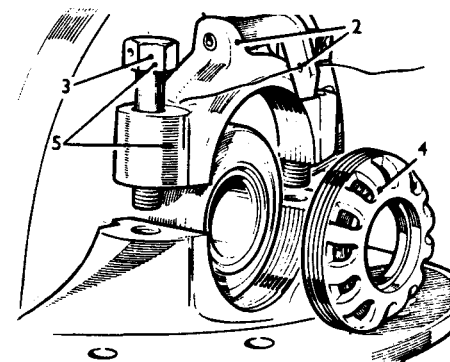

0708

- 6 Lift out the crown wheel, differential unit and bearings.
- 7 Remove the split pin, slotted nut and washers securing the pinion flange. Flange holder tool 18G 1205.
- 8 Withdraw the pinion flange.

continued

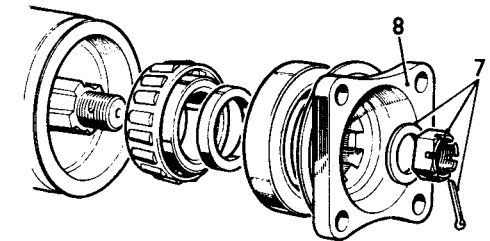

0706

- 9 Withdraw the pinion complete with pinion head bearing and outer bearing shims. Withdraw the shims.
- 10 Remove the pinion flange oil seal, spacer and bearing. Discard the oil seal.
- 11 Remove the pinion head bearing track and shim and the outer bearing track from the differential housing. Tool 262757.
- 12 Remove the pinion head bearing. Tool 18G 47 BK.
- 13 Remove the bolts and washers securing the crown wheel to the differential flange. Withdraw the crown wheel.
- 14 Remove the differential carrier bearings.
- 15 Remove the circlips securing the differential cross shaft. Extract the cross shaft.
- 16 Withdraw the differential gears and pinions.
- 17 Thoroughly clean all components.

Inspecting

- 18 Check all bearings for wear and/or pitting.
- 19 Check all gears for wear, scuffing, pitting and damaged teeth.
- 20 Note: The crown wheel and pinion are supplied as a matched set, and also the pinion housing and bearing caps.

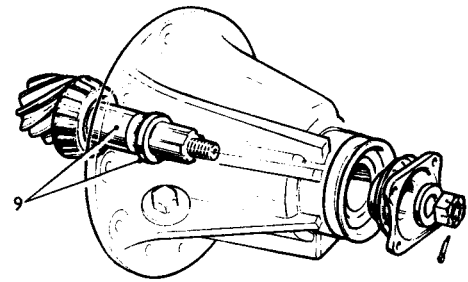
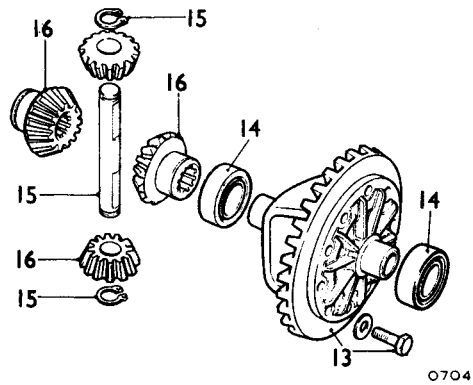

O703

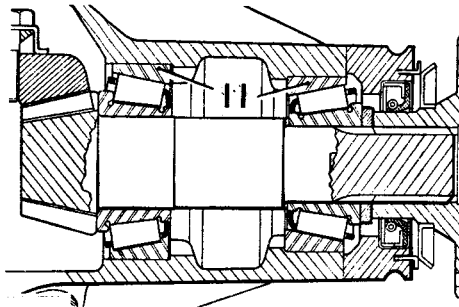

O707

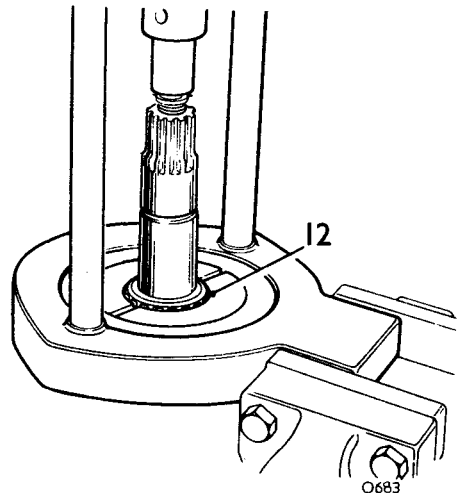

O683

Assembling

Differential gears

- 21 Fit the differential gears to the differential housing.
- 22 Fit the differential cross shaft and retaining circlips.
- 23 Check the gears for freedom of rotation and backlash. Nominal backlash should be present. Excessive backlash will necessitate renewal of the gears and/or the differential housing. No provision is made for backlash adjustment.
- 24 Ensuring that the differential housing flange and crown wheel are thoroughly clean fit the crown wheel bolts and washers and evenly tighten.
- 25 Fit the carrier bearings and bearing tracks.
- 26 Place the differential housing complete with crown wheel and bearings in the pinion housing.
- 27 Fit the bearing caps and bolts. Do not fully tighten the bolts.
- 28 Fit the bearing adjusting nuts and adjust to obtain zero end-float.
- 29 Tighten the bearing cap bolts.
- 30 Using a dial gauge check the crown wheel for run-out. This should not exceed 0,10 mm (0.004 in.). If excessive run-out is recorded remove the crown wheel and examine crown wheel and mounting flange for burrs, grit etc. Refit the crown wheel and recheck. Run-out, attributable to a buckled or damaged differential housing flange can be corrected only by renewing the differential gear housing.
- 31 When satisfied that run-out is within the specified limits remove the differential housing from the pinion housing.
- 32 Remove the crown wheel bolts and refit them using Loctite Studloc. Evenly tighten the bolts to 6,3 to 7,6 kgf. m (45 to 55 lb. ft.).

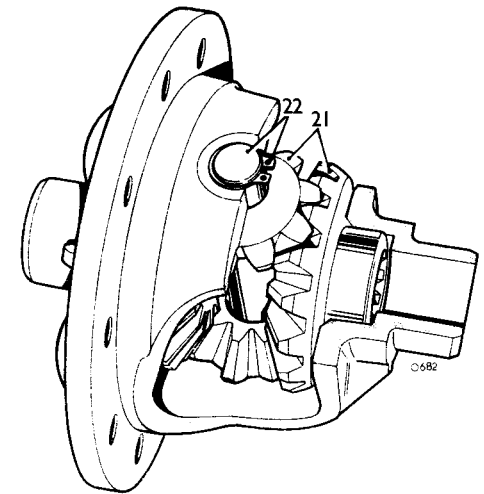

O682

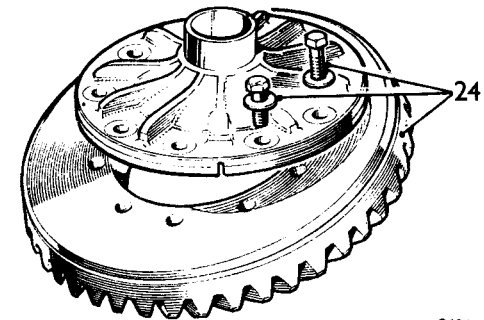

O686

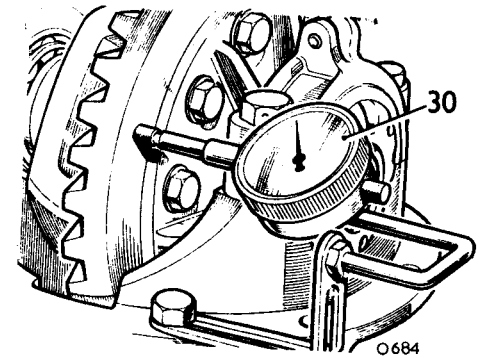

O684

Pinion

- 33 Fit the pinion head bearing track and the original shim to the pinion housing. Tools 262758, 262757. If the original shim was damaged or mislaid use a new shim of at least 1,27 mm (0.050 in.) thickness.
- 34 Fit the pinion outer bearing track to the pinion housing.
- 35 Fit the pinion head bearing to the pinion.
- 36 Slide the original shim (bearing pre-load) into position on the pinion shaft. If the original shim was damaged or mislaid use a new shim of at least 4,06 mm (0.160 in.) thickness.
- 37 Enter the pinion in its location in the pinion housing and fit the outer bearing and spacer.
- 38 Fit the driving flange, washer and nut. Do not fit the oil seal at this stage.
- 39 With the pinion flange nut tightened to a torque of 9,6 to 16,5 kgf. m (70 to 120 lbf. ft.) the force required to rotate the pinion shaft should be within 6,9 to 28,7 kgf. cm (6 to 25 lbf. ins.) when initial inertia has been overcome. Change the bearing pre-load shim as necessary to obtain this requirement. A thicker shim will reduce pre-load; a thinner shim will increase pre-load.
- 40 Locate the pinion height gauge in the pinion housing and secure with the bearing caps.

NOTE: Four variations of height gauge are in use. These are 601998, 262761, 600299 and 605004; any of these gauges may be used.

- 41 Place the slip gauge on the pinion face and hold firmly in place.

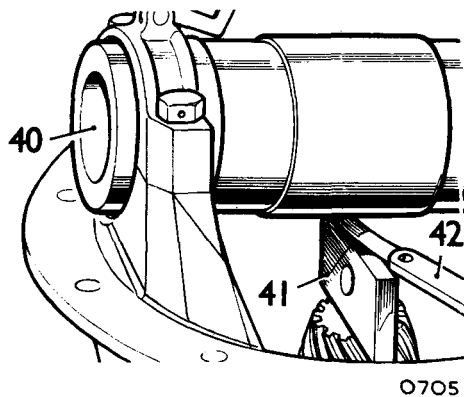
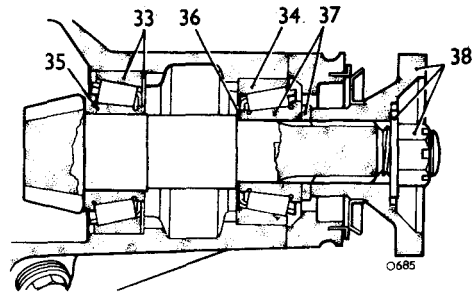

- 42 Using feeler gauges measure the clearance between the slip gauge and the height gauge.
The required clearance is:
Height gauges 601998, 262761 and 600299. - 0,07 to 0,10 mm (0.003 to 0.004 in.).
Height gauge 605004. - 0,28 to 0,30 mm (0.011 to 0.012 in.).
Determine the shim thickness required for the pinion head bearing to obtain the above requirement.

- 43 Remove the pinion head bearing track and substitute a shim of the calculated thickness.

NOTE: Adjustment to the pinion head shim will necessitate an equal plus or minus adjustment to the bearing pre-load shim.

- 44 Refit the pinion head bearing and recheck clearance (Instruction 42).
- 45 If clearance is satisfactory remove the pinion height gauge. If clearance is incorrect repeat instruction 43.
- 46 Remove the pinion flange.
- 47 Smear the outer periphery of the new pinion flange oil seal with jointing compound. Fit the oil seal (seal lips towards the pinion).
- 48 Lubricate the seal lips and fit the flange, nut and split pin. Nut torque (70 to 120 lbf. ft.).
- 49 Place the differential housing in the pinion housing.
- 50 Fit the bearing caps and bolts. Do not fully tighten the bolts.
- 51 Fit the bearing adjusting nuts.
- 52 Set crown wheel/pinion backlash to 0,20 to 0,25 mm (0.008 to 0.010 in.) with zero end-float. Move the serrated adjusting nuts in direction A to reduce backlash; move in direction B to increase backlash.
- 53 Tighten both adjusting nuts half a serration.
- 54 Evenly tighten the bearing cap bolts torque 8,3 kgf. m (60 lbf. ft.).
- 55 Recheck crown wheel/pinion backlash.
- 56 Bend the locking fingers to accommodate adjusting nut serrations as required. Fit the locking fingers and roll pins.
- 57 Lubricate the bearings and gears.

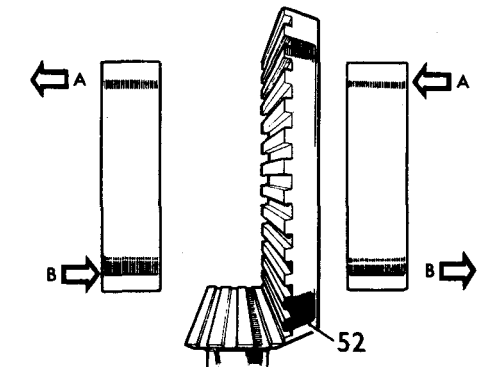
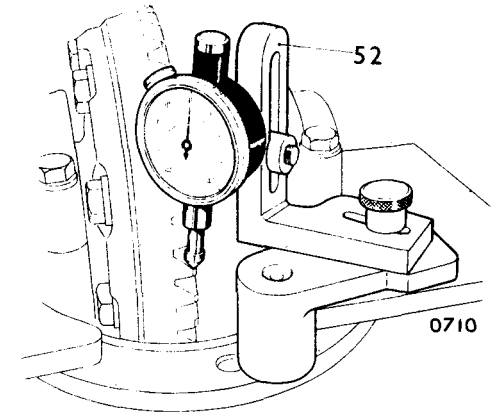

DATA

- Pinion bearing pre-load
- Pinion height setting
- Crown wheel run-out
- Crown wheel/pinion backlash

- 7.6 to 13 kgf. cm (7 to 12 lbf. ins.)
- Gauges. 601998, 262761, 600299
0,07 to 0,10 mm (0.003 to 0.004 ins.)
- Gauge. 605004
0,28 to 0,30 mm (0.011 to 0.012 in.)
- 0,10 mm (0.004 in.)
- 0,20 to 0,25 mm (0.008 to 0.010 in.)

DIFFERENTIAL ASSEMBLY

From the following axle numbers:
 109" and 88" Land Rover front axle right hand drive 91133272H
 109" and 88" Land Rover front axle left hand drive 91452230H
 88" Land Rover rear axle 90260573G

Overhaul 54.10.07

- Service tools:**
 18G 1205 Flange holding wench.
 18G 191 Pinion height setting gauge.
 18G 191-4 Universal setting block.
 18G 47-6 Pinion head bearing remover/replacer
 18G 1382 Oil seal replacer.
 RO 262757A Extractor for pinion bearing cups.
 RO 262757-1 Replacer — use with RO 262757A.
 RO 262757-2 Adaptor tail bearing cup replacer.
 RO 530105 Spanner — differential flange and carrier bearing nuts.
 RO 530106 Bracket for dial gauge indicator.
 MS 47 Press.

Dismantling

It is essential that differential components are marked in their original positions and relative to other components so that, if refitted, their initial setting is maintained.

NOTE: The bearing caps must not be interchanged.

- 1 Remove the differential assembly from the axle.54.10.01.
- 2 Drift out the roll pin securing the bearing nut locking fingers to the bearing caps. Remove the locking fingers.
- 3 Slacken the bearing cap bolts, and mark the caps for reassembly.
- 4 Remove the bearing adjusting nuts.
- 5 Remove the bearing cap bolts and bearing caps.

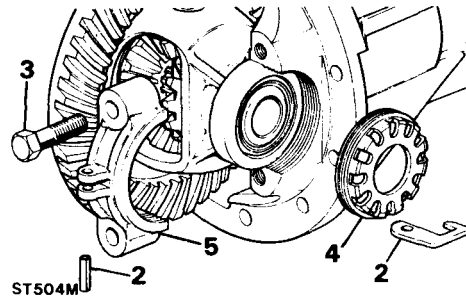

- 6 Lift out the crown wheel, differential unit and bearings.
- 7 Remove the split pin securing the pinion flange nut.
- 8 Remove the pinion flange nut using Service tool 18G 1205.

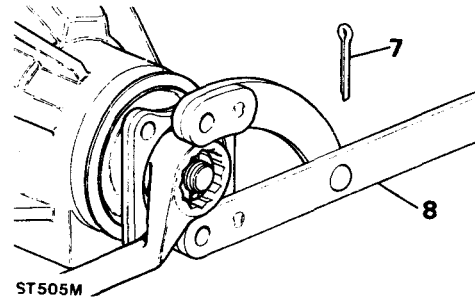

- 9 Withdraw the pinion complete with pinion head bearing and outer bearing shims. Withdraw the shims.
- 10 Remove the pinion flange oil seal spacer and bearing. Discard the oil seal.

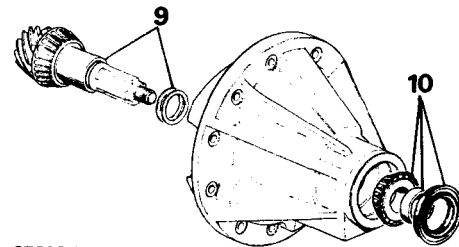

- 11 Using Service tool RO 262757A, remove the pinion head bearing track from the differential housing.

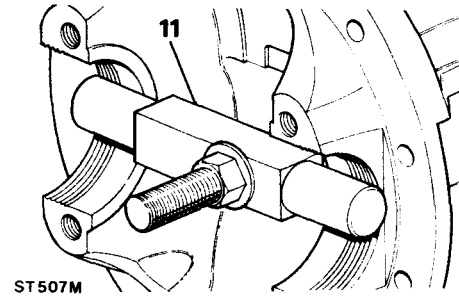

- 12 Remove the pinion head bearing with service tool MS47 and adaptor 18G 47-6.

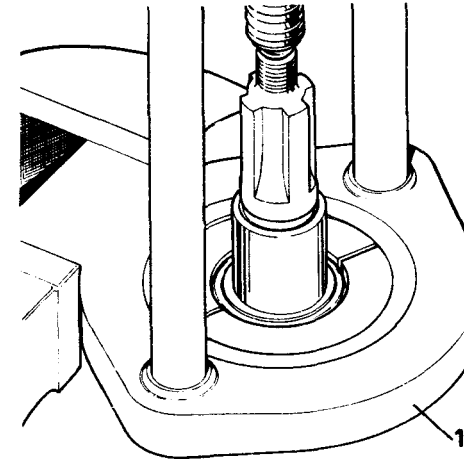

- 13 Remove the bolts and washers securing the crown wheel to the differential flange. Withdraw the crown wheel.
- 14 Remove the differential carrier bearings.
- 15 Remove the circlips securing the differential cross shaft. Extract the cross shaft.
- 16 Withdraw the differential gears and pinions.
- 17 Thoroughly clean all components.

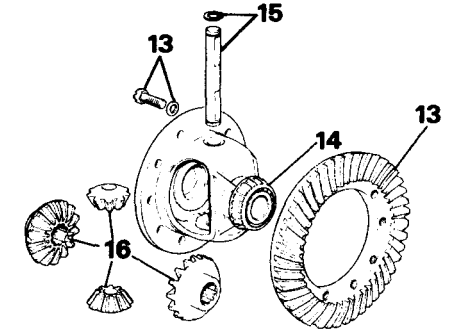

ST509M

Inspecting

- 18 Check all bearings for wear and/or pitting.
- 19 Check all gears for wear, scuffing, pitting and damaged teeth.
- 20 **NOTE:** The crown wheel and pinion are supplied as a matched set, also the pinion housing and bearing caps.

Assembling

- Differential gears**
- 21 Fit the differential gears to the differential housing.
 - 22 Fit the differential cross shaft and retaining circlips.

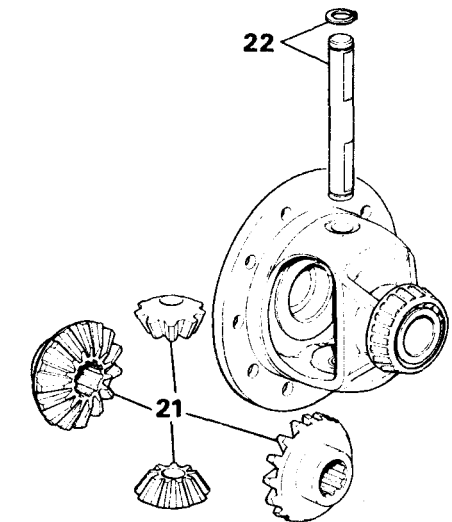

ST510M

continued

- 23 Check the gears for freedom of rotation and backlash. Nominal backlash should be present. Excessive backlash will necessitate renewal of the gears and/or the differential housing. No provision is made for backlash adjustment.
- 24 Ensuring that the differential housing flange and crown wheel are thoroughly clean fit the crown wheel. Fit the crown wheel bolts and washers and evenly tighten.
- 25 Fit the carrier bearings using a suitable press or drift and assemble the tracks to the bearings.

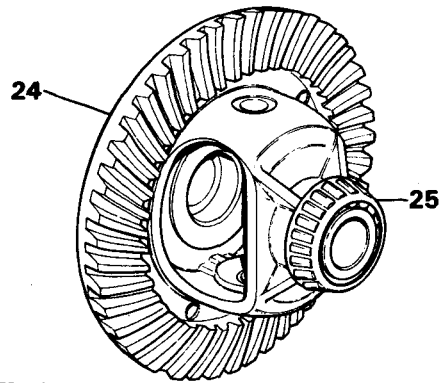

ST511M

- 26 Place the differential housing complete with crown wheel and bearings in the pinion housing.
- 27 Fit the bearing caps and bolts. Do not fully tighten the bolts.
- 28 Fit the bearing adjusting nuts and adjust to obtain zero end-float.
- 29 Tighten the bearing cap bolts.

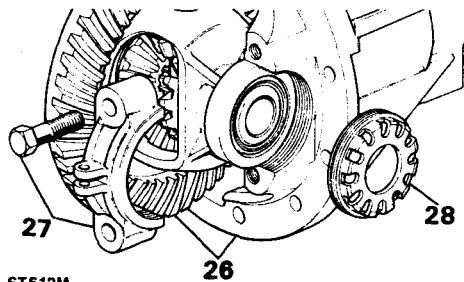

ST512M

- 30 Using a dial gauge check the crown wheel for run-out. This should not exceed 0.10 mm (0.004 in). If excessive run-out is recorded remove the crown wheel and examine crown wheel and mounting flange for burrs, grit etc. Refit the crown wheel and recheck. Run-out, attributable to a buckled or damaged differential housing flange can be corrected only by renewing the differential gear housing.
- 31 When satisfied that run-out is within the specified limits remove the differential housing from the pinion housing.
- 32 Remove the crown wheel bolts and refit them using Loctite Studloc. Evenly tighten the bolts to 6,3 and 7,6 kgf. m (45 to 55 lbf. ft.).

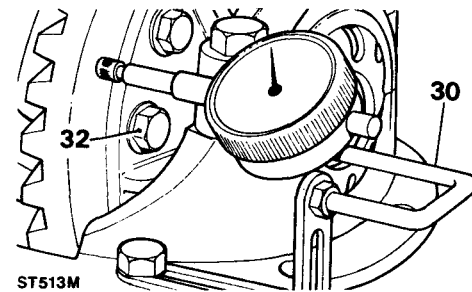

ST513M

Pinion

- 33 Fit the pinion head bearing track and the original shim to the pinion housing, using Service tools RO 262757A and RO 262757-1. If the original shim was damaged or mislaid use a new shim of at least 1,27 mm (0.050 in) thickness.
- 34 Fit the pinion outer bearing track to the pinion housing with Service tool RO 262757A and RO 262757-2.

NOTE: Instructions 33 and 34 are carried out in one operation, as illustrated.

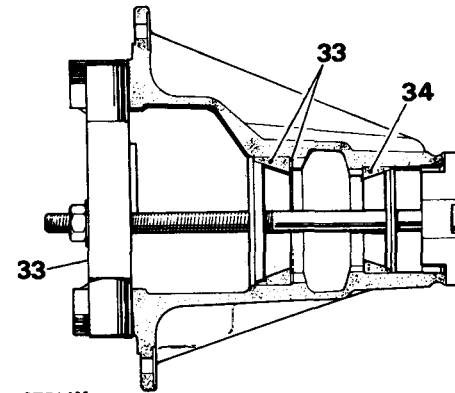

ST514M

- 35 Fit the pinion head bearing to the pinion using Service tools MS 47 and 18G 47-6.

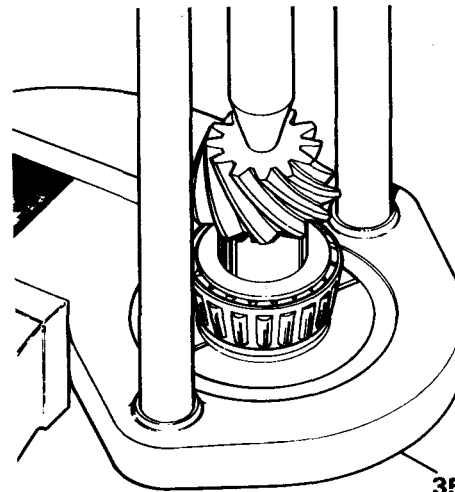

ST515M

- 36 Slide the original shim (bearing pre-load) into position on the pinion shaft. If the original shim was damaged or mislaid use a new shim of at least 4,06 mm (0.160 in) thickness.
- 37 Enter the pinion in its location in the pinion housing and fit the outer bearing and spacer.

- 38 Fit the driving flange washer and nut.
- 39 Do not fit the oil seal at this stage.
- 40 With the pinion flange nut tightened to a torque of 9,6 to 16,5 kgf. m (70 to 120 lbf. ft.) the force required to rotate the pinion shaft should be within 6,9 to 28,7 kgf. cm (6 to 25 lbf. in) when initial inertia has been overcome. Change the bearing pre-load shim as necessary to obtain this requirement. A thicker shim will reduce pre-load; a thinner shim will increase pre-load.

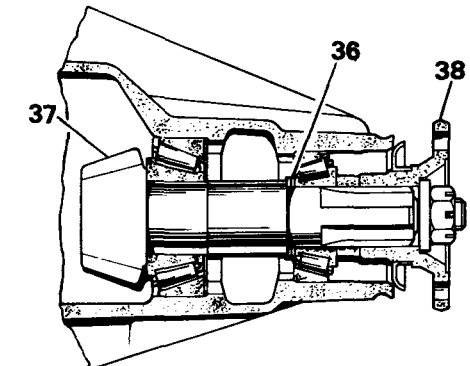

ST516M

Drive pinion markings

- 41 Check that the serial number marked on the pinion end face matches that marked on the crown wheel.
- 42 The markings on the end face adjacent to the serial number are of no significance during servicing.
- 43 The figure marked on the end face opposite to the serial number indicates, in thousandths of an inch, the deviation from nominal required to correctly set the pinion. A pinion marked plus (+) must be set below nominal, a minus (-) pinion must be set above nominal. *An unmarked pinion must be set at nominal.*
- 44 The nominal setting dimension is represented by the setting gauge block 18G 191-4 which is referenced from the pinion end face to the bottom radius of the differential bearing bore.

continued

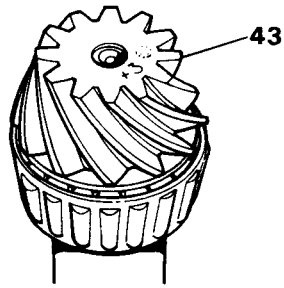

ST517

Drive pinion adjustment

- 45 Ensure that the pinion end face is free of raised burrs around the etched markings.
- 46 Remove the keep disc from the magnetised base of dial gauge tool 18G 191.
- 47 Place the dial gauge and setting block on a flat surface and zero the dial gauge stylus on the setting gauge.

NOTE: The setting block has three setting heights as follows:

- 39.50 Rationalised axle.
- 38.10 Pre-rationalised axle.
- 30.93 Salisbury axle.

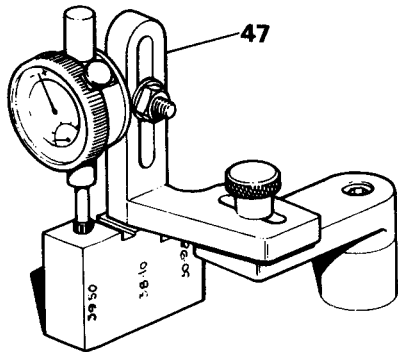

ST518M

- 48 Position the dial gauge centrally on the pinion end face with the stylus registering on the lowest point on one differential bearing bore. Note the dial gauge deviation from the zeroed setting.

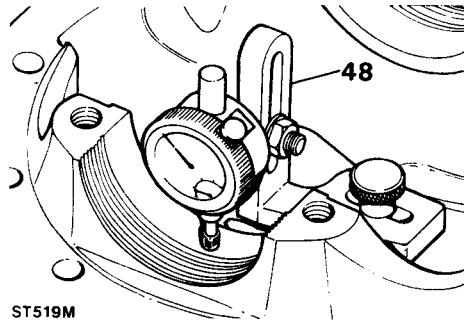

ST519M

- 49 Repeat on the other bearing bore. Add together the readings then halve the sum to obtain the mean reading. Note whether the stylus has moved up or down from the zeroed setting.
 - a Where the stylus has moved down, the amount is equivalent to the thickness of the shims that must be removed from under the pinion inner cup to bring the pinion down to the nominal position.
 - b Where the stylus has moved up, the amount is equivalent to the additional thickness of shims required to bring the pinion up to the nominal position.
- 50 Before adjusting the shim thickness check the pinion face marking and if it has a plus (+) figure, subtract that amount in thousandths of an inch from the shim thickness figure obtained in the previous item.
- 51 Alternatively, if the pinion has a minus (-) figure, add the amount to the shim thickness figure. Adjust the shim thickness under the pinion inner cup as necessary.
- 52 Recheck the pinion height setting; if the the setting is correct, the mean reading on the dial gauge will agree with the figure marked on the pinion end face. For example, with an end face marking of +3, the dial gauge reading should indicate that the pinion is +0.003in.
- 53 Remove the pinion flange.

- 54 Smear the outer periphery of the new pinion flange oil seal with jointing compound. Fit the oil seal (seal lips toward the pinion) using Service tool 18G 1382 oil seal replacer.

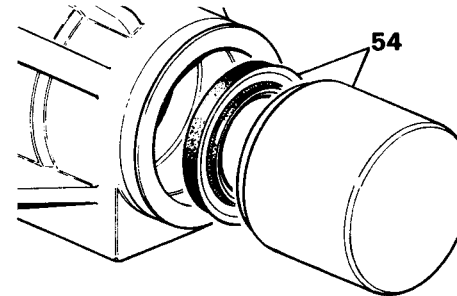

ST520M

- 55 Lubricate the seal lips and apply grease to the seal spring. Fit the distance piece and flange and secure with the washer, nut and new split pin. Tighten the nut to 9.6 to 16.5 kgf. m (70 to 120 lbf. ft.).

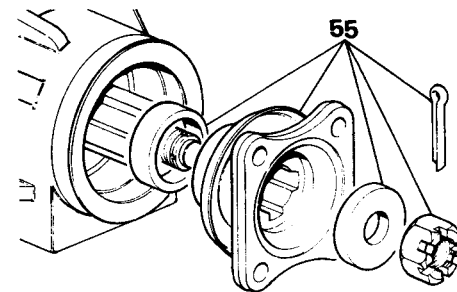

ST521M

- 56 Place the differential housing in the pinion housing.
- 57 Fit the bearing caps and bolts. Do not fully tighten the bolts.
- 58 Fit the bearing adjusting nuts.

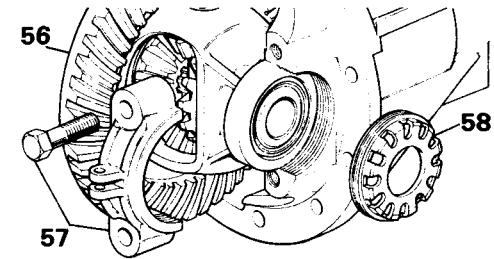

ST522M

- 59 Set crown wheel/pinion backlash to 0,20 to 0,25 mm (0.008 to 0.010 in) with zero end-float. Move the serrated adjusting nuts in direction A to reduce backlash,

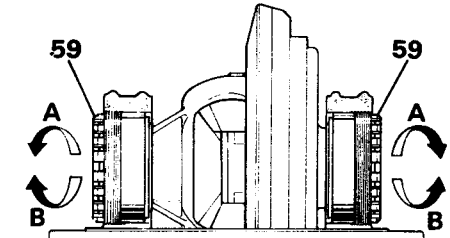

ST523M

- move in direction B to increase backlash.
- 60 Tighten both adjusting nuts half a serration.
- 61 Evenly tighten the bearing cap bolts torque 8,3 kgf. m (60 lbf. ft).
- 62 Recheck crown wheel/pinion backlash.
- 63 Bend the locking fingers to accommodate adjusting nut serrations as required. Fit the locking fingers and roll pins.
- 64 Lubricate the bearings and gears.

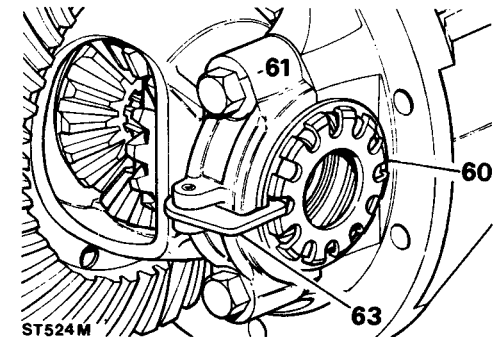

ST524M

PINION OIL SEAL

Remove and refit

54.10.20

Service Tool: 18G 1205. Flange holder.

Removing

- 1 Disconnect the propeller shaft from the front axle driving flange.
- 2 Remove the split pin, nut and washer securing the driving flange. Use tool 18G 1205 to hold the flange when slackening the nut. Do not impose loading on the pinion teeth.
- 3 Withdraw the driving flange.
- 4 Prise out the oil seal and discard.

Refitting

- 5 Thoroughly clean the seal recess in the pinion housing.
- 6 Smear the outer periphery of the new seal with jointing compound.
- 7 Evenly insert the seal. (Seal lip towards axle.)
- 8 Lubricate the seal lip and the seal contact area on the driving flange.
- 9 Fit the flange, washer and nut. Torque 9,6 to 16,5 kgf. m. (70 to 120 lbf. ft.). Fit a new split pin.
- 10 Connect the propeller shaft to the driving flange.

NOTE: Oil seal leakage can be caused by over-filled axle, worn driving flange or a restricted axle breather.

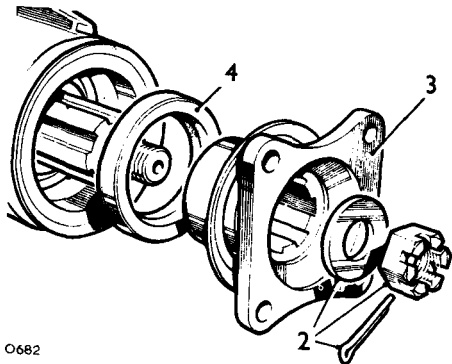

0682

FRONT AXLE ASSEMBLY

Remove and refit

54.15.01

Service tool: 601763. Ball joint extractor.

Removing

- 1 Slacken front wheel nuts.
- 2 Jack up the front of the vehicle and support the chassis securely on stands.
- 3 Remove the front wheels.
- 4 Disconnect the front propeller shaft from the front axle.
- 5 Disconnect the steering drag link from the relay lower lever using tool 601763 to release the ball joint.
- 6 Disconnect the lower ends of the shock absorbers from the front spring bottom plates.
- 7 Remove the four 'U' bolts and bottom plates securing the axle to the road springs.
- 8 Slacken the front spring shackle bolts.
- 9 Disconnect the front brake pipe unions from the front brake hoses.
- 10 Release the brake hoses from their respective chassis brackets.
- 11 Seal the brake pipe and brake hose to prevent ingress of foreign matter and loss of fluid.
- 12 Support the axle on a jack.
- 13 With an assistant to steady the axle withdraw the front shackle bolts and lower the front of the springs to the ground.
- 14 Carefully lower the jack and withdraw the front axle.

Refitting

- 15 Using a jack and with the aid of an assistant, locate the axle in its approximate position under the vehicle.
- 16 Raise both front springs and fit the front shackle bolts and nuts. **DO NOT** tighten the shackle bolts, front or rear at this stage.
- 17 Lower the axle on top of the road springs ensuring that the spring centre bolts properly engage their axle locations.
- 18 Fit the 'U' bolts (short 'U' bolts outboard), spring bottom plates and nuts. Torque the nuts evenly to 10,4 kgf m (75 lbf ft).

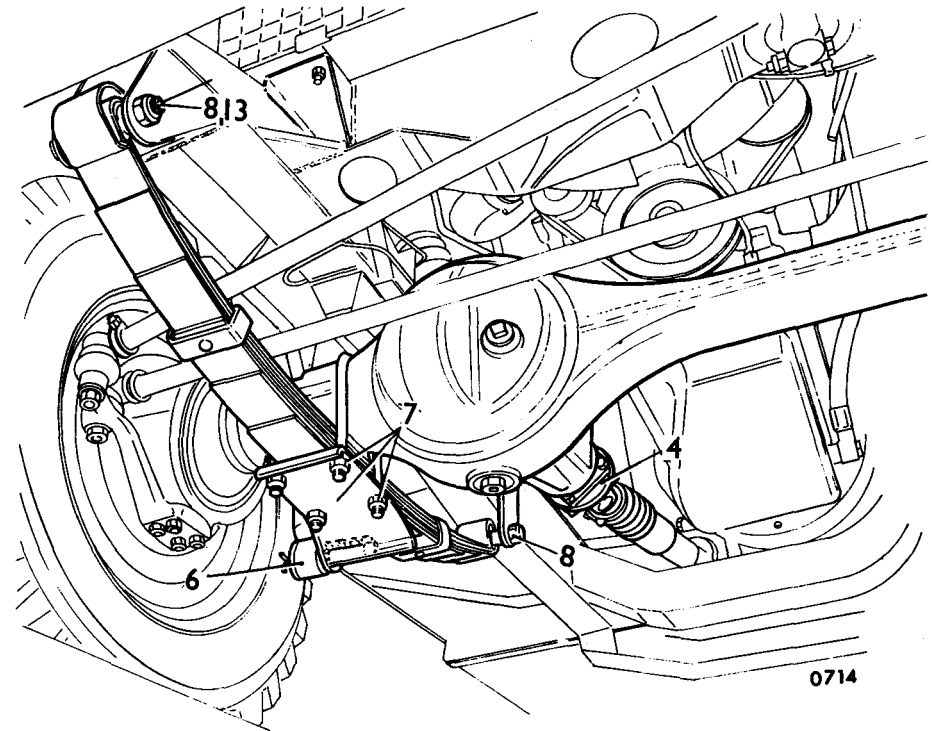

0714

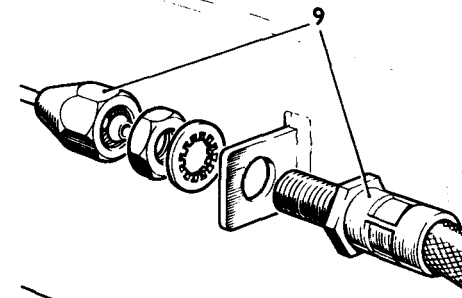

0702

- 19 Engage the brake hoses in their respective chassis brackets and secure with shakeproof washer and nut. Ensure that the hoses are not twisted or kinked.

- 20 Fit the brake pipes to the brake hoses.
- 21 Connect the propeller shaft to the front axle.
- 22 Connect the drag link to the steering relay lever.
- 23 Connect the shock absorbers to the spring bottom plate.
- 24 Bleed the brakes. 70.25.02.
- 25 Adjust the front brakes as necessary.
- 26 Check and if necessary adjust the steering stop 57.65.03.
- 27 Fit the road wheels.
- 28 Remove the chassis stands and lower the vehicle to the ground.
- 29 Evenly tighten the road wheel nuts. Torque.
- 30 Check axle and swivel joint oil levels and top up as required.
- 31 Tighten all front spring shackle bolts. Refer 60.20.01 instructions 11 to 13.

AXLE CASE OIL SEAL

Removing and refit

54.15.04

Removing

- 1 Remove the half shaft and swivel axle assembly. 54.20.01.
- 2 Prise out the axle case oil seal.

Refitting

- 3 Smear the oil seal outside periphery with jointing compound.
- 4 Fit the oil seal, lip inward towards the axle.
- 5 Fit the joint washer using jointing compound.
- 6 Reverse instruction 1.

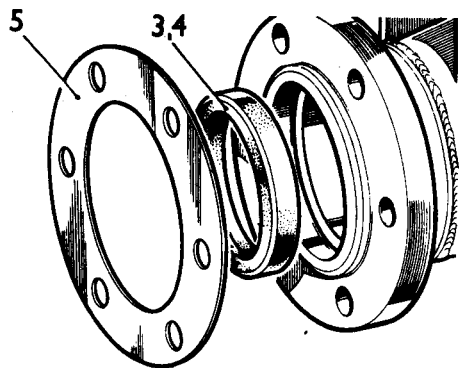

0711

HALF SHAFT AND SWIVEL AXLE

Remove and refit

54.20.01

Service tool: 601763 Ball joint extractor.

Removing

- 1 Slacken the road wheel nuts associated with the half shaft to be removed.
- 2 Jack up the front of the vehicle and support securely on stands.
- 3 Remove the road wheel.
- 4 Disconnect the track rod end from the track arm. Tool 601763. If the swivel axle to be removed is on the steering wheel side of the vehicle disconnect also the drag link from the steering arm.
- 5 Disconnect the brake pipe union nut from the flexible brake hose.

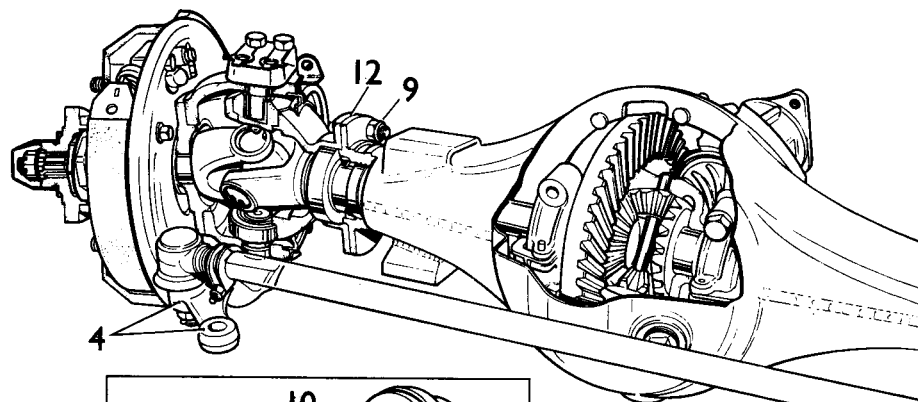

0712

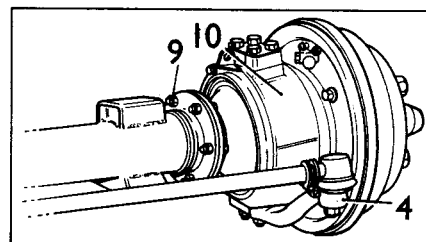

- 6 Disconnect the flexible brake hose from its bracket.
- 7 Seal the brake pipe and hose to prevent loss of fluid and to prevent the ingress of foreign matter.
- 8 Note the location of the steering stop bracket and the jack stop plate fitted to the axle flange.
- 9 Remove the six bolts and nuts clamping the swivel axle/front axle flanges.
- 10 Withdraw the half shaft and swivel axle assembly.

Refitting

- 11 Thoroughly clean the swivel axle and front axle flanges.
- 12 Using jointing compound fit a new gasket to the axle flange.
- 13 Reverse instructions 1 to 10.
- 14 Bleed the brakes.

HALF SHAFT

Remove and refit

54.20.07

Removing

- 1 Drain the swivel housing.
- 2 Remove the wheel hub. 60.25.01.
- 3 Remove the stub axle. 60.25.22.
- 4 Withdraw the axle half shaft complete.

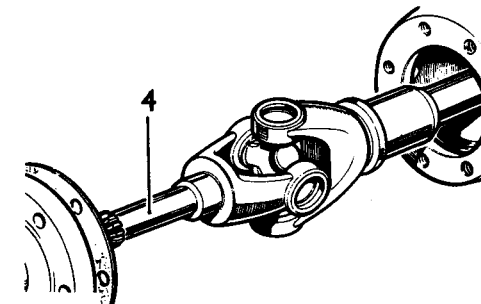

0700

Refitting

- 5 Fit the half shaft, long end first, taking care to avoid damaging the axle case oil seal.
- 6 Carry out the following check, item 7, at the top and bottom swivel pins with the yokes at the maximum angle with the chamfered radius closest to the swivel pin end face.
- 7 Rotate the half shaft and check that there is a minimum clearance of 1,2 mm (0.050 in.) between the joint yoke ears and the swivel pin end faces.
- 8 If the clearance is insufficient, increase the chamfer on the yoke ears radius.
- 9 Reverse instructions 1 to 3.

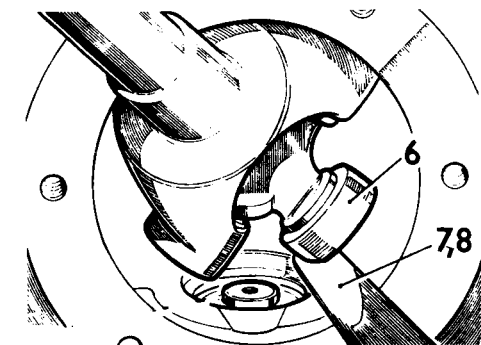

0701

HALF SHAFT

Overhaul

54.20.09

Service tool: 275870. Axle shaft collar remover/replacer

Dismantling the universal joint

- 1 Remove the half shaft. 54.20.07.
- 2 Remove the circlips from the universal joint.
- 3 With one of the stub shaft yoke lugs uppermost tap the radius of the yoke.
- 4 The top bearing should then begin to emerge from the yoke.

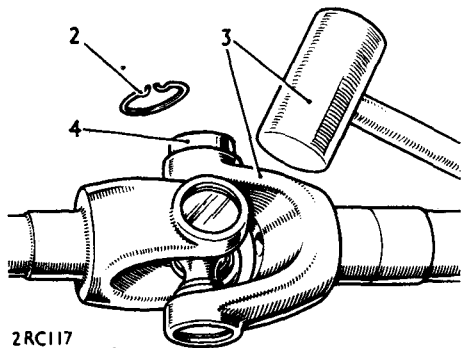

2RC117

- 5 Turn the joint over and withdraw the bearing downwards to retain the needle rollers.
- 6 Repeat items 2 to 5 to remove the opposite bearing.

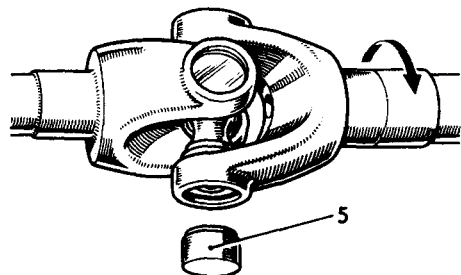

2RC118

- 7 Separate the stub shaft from the spider journals.
- 8 Remove the half shaft bearings in the same manner as already described for the stub shaft.
- 9 Clamp the extractor tube in a vice.

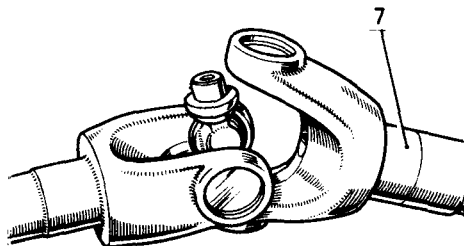

2RC119

- 10 Position adaptor No. 2 or No. 3, as applicable, onto the shaft and insert the assembly into the extractor tube.
- 11 Secure the shaft to the extractor, using adaptor No. 5.
- 12 Screw in the arm and press the shaft from the retainer collar, bearing and conical distance piece.
- 13 Remove the adaptors, discard the retaining collar.

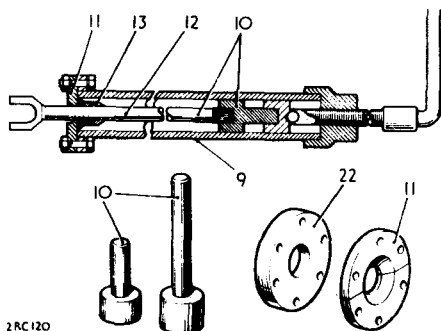

2RC120

Inspection

- 14 Examine all components for obvious wear or damage.
- 15 If the journal or bearings for the universal joint show any signs of wear, load markings or distortion, they must be renewed completely.
- 16 The bearing races should be a light press fit in the yoke trunnions.
- 17 In the event of wear taking place in any of the four yoke holes, rendering them oval, a new stub shaft or half shaft must be fitted.
- 18 The bearing inner race must be a light press fit on the axle half shaft.

Reassembling the half shaft

- 19 Fit the conical distance piece over the half shaft with the internal chamfer to the radius on the shaft.
- 20 Place the roller race inner member and a new retaining collar over the half shaft with the chamfer towards the splined end.
- 21 Stand the shaft on end on a block of hard wood.
- 22 Bolt adaptor No. 4 to the tool with the recess towards the collar.
- 23 Drive the collar onto the shaft, using the extractor tube as a ram.

Reassembling the universal joint.

- 24 Assemble the needle rollers in the bearing races, if necessary using a smear of vaseline to retain them in place.
- 25 Insert the journal in the stub shaft yoke holes, and using a brass drift slightly smaller in diameter than the hole in the yoke, press the first bearing into position, and retain with a circlip.
- 26 Repeat the foregoing operation for the other three bearings.
- 27 Ensuring that all four circlips are firmly located in their grooves.
- 28 Check that the universal joint moves freely. If the joint appears to bind, hold one shaft so that the joint hangs free and tap the yoke ears lightly with a mallet.
- 29 Fit the half shaft and swivel axle assembly 54.20.01.

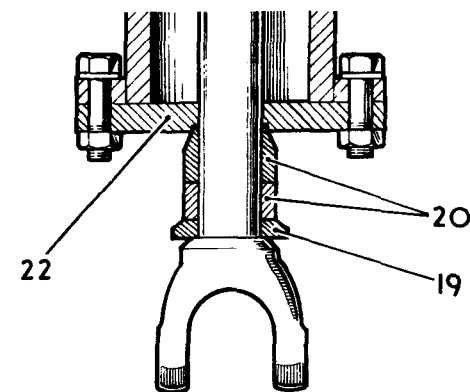

2RC121

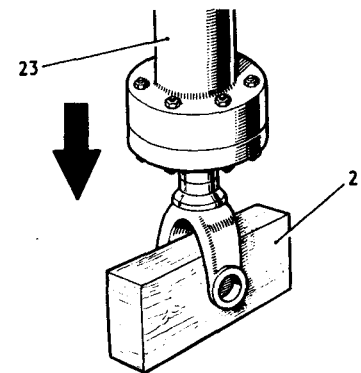

2RC122

STEERING BOX

Adjust

57.35.01

Procedure

- 1 Set the road wheels in the straight ahead position.
- 2 Slacken the adjuster locknut.
- 3 Tighten the adjuster to reduce steering wheel backlash.
- 4 Tighten the locknut.

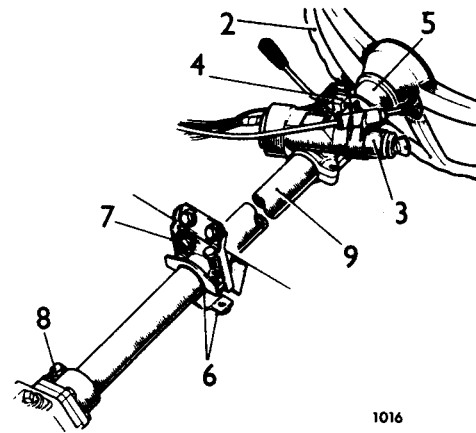
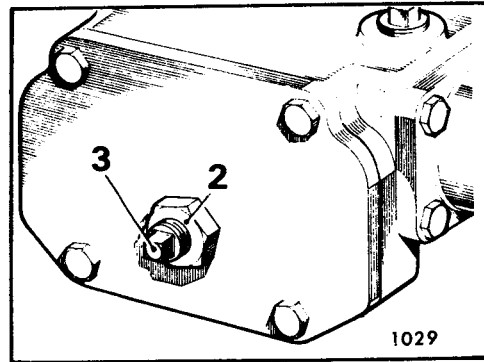

STEERING COLUMN TOP BEARING

Remove and refit

57.40.19

Removing

- 1 Disconnect the battery.
- 2 Remove the steering wheel. 57.60.01.
- 3 Remove the steering column lock. 57.40.31.
- 4 Remove the combination switch. 86.65.55.
- 5 Remove the direction indicator striker assembly and spring.
- 6 Remove the column clamp bracket and rubber.
- 7 Slacken the clamp adjuster bolts.
- 8 Slacken the pinch bolt securing the outer column to the steering box.
- 9 Withdraw the outer column.
- 10 Remove the column top bearing.

Refitting

- 11 Reverse instructions 1 to 10.

STEERING DAMPER

Remove and refit

57.35.10

Removing

- 1 Remove the locknut and nut securing the damper to the chassis bracket.
- 2 Remove the damper outer rubber mounting complete with inner and outer seating washers.
- 3 Repeat instructions 1 and 2 at the drag link end of the steering damper.
- 4 Withdraw the damper.
- 5 Remove the damper inner rubber mountings complete with inner and outer seating washers.

Refitting

- 6 Fit the inner rubber mountings complete with inner and outer seating washers to both ends of the damper.
- 7 Locate the damper in position on the vehicle engaging the drag link and chassis bracket. Ensure that the sleeved end of the damper is fitted to the chassis bracket.
- 8 Fit the outer rubber mountings and inner and outer seating washers.
- 9 Fit the securing nuts and locknuts.

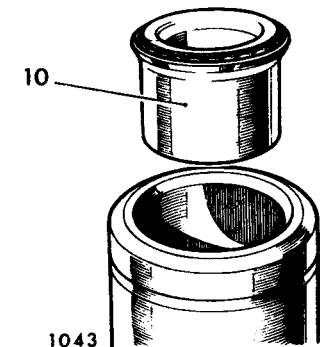
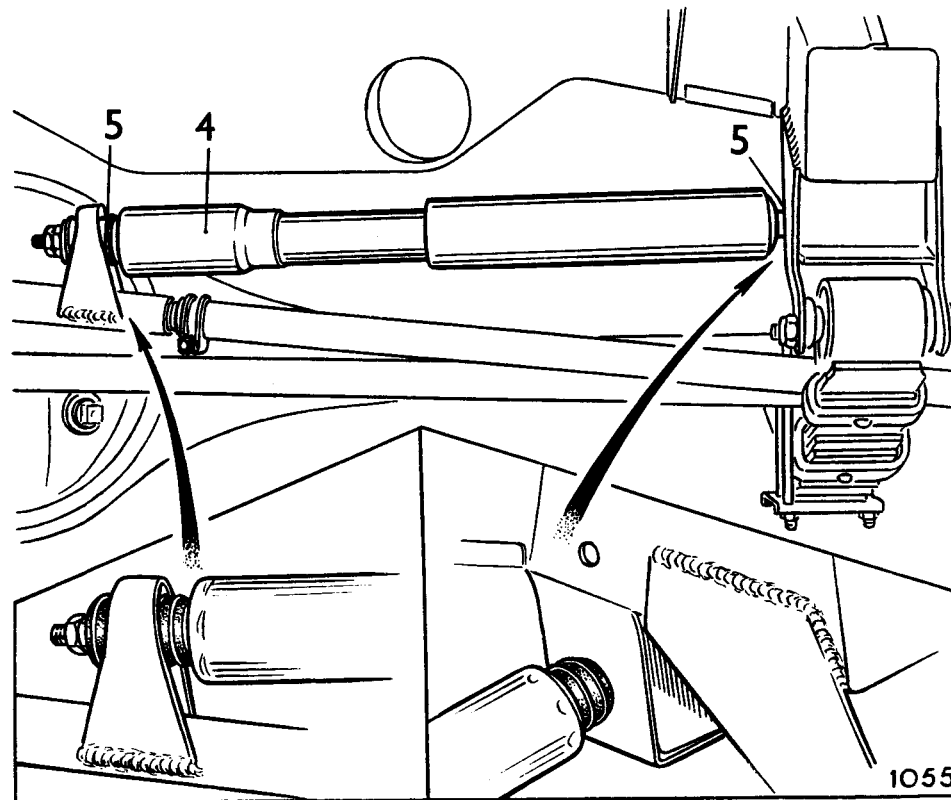

STEERING COLUMN LOCK/ IGNITION/STARTER SWITCH ASSEMBLY

Remove and refit 57.40.31

Removing

- 1 Disconnect the battery
- 2 Petrol models – disconnect the choke cable at the carburetter.
Diesel models – disconnect the 'stop' cable at the injection pump.
- 3 Remove the steering column shroud.
- 4 Remove the lower fascia.
- 5 Using a centre punch carefully unscrew the sheared heads of the steering lock securing bolts. Should the bolts not unscrew using this method, drill the bolt centres and remove the bolts with an 'Easiout' extractor.
- 6 Withdraw the steering column lock and clamp.
- 7 Disconnect the electrical leads from the ignition/starter switch.
- 8 If required remove the fixing screws and remove the switch and also the choke or engine stop control as applicable.

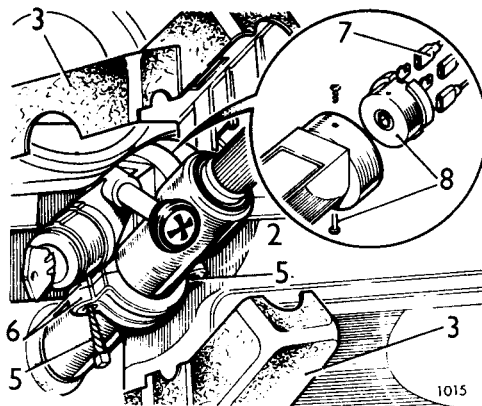

Refitting

- 9 Reverse instructions 8 as required.
- 10 Connect the electrical leads.
- 11 Reverse instructions 1 to 6.
- 12 Check the operation of the steering locks.
Petrol models – The steering column should be unlocked when the ignition/starter key is at the 'Services' position and locked when the key is withdrawn.
Diesel models – The engine stop control should be automatically locked out in the engine stop condition when the steering column is locked and free to return when the '11' position is selected on the lock/starter switch.

STEERING COLUMN AND BOX ASSEMBLY

Remove and refit 57.45.01

Service tool: 600000 Drop arm remove
601763 Ball joint extractor

Removing

- 1 Fully open or remove the bonnet panel.
- 2 Disconnect the battery.
- 3 R.H. stg. models, remove the air cleaner.
- 4 Remove the steering wheel. 57.60.01.
- 5 Remove the lower fascia.
- 6 Remove the combined switch from the steering column. 86.65.55.
- 7 Where fitted, remove the steering column lock. 57.40.31.
- 8 On vehicles without a steering column lock, unscrew the lock ring and move aside the ignition/starter switch from the mounting bracket.
- 9 Remove the lower clamp bracket and rubber sleeve from the outer column.
- 10 Remove the upper clamp bracket and support bracket from the bulkhead.
- 11 Disconnect the steering drop arm and the attached longitudinal steering tube from the steering box, using tool 600000.
- 12 L.H. stg., 2½ litre Petrol models – disconnect the throttle linkage at the bracket attached to the steering box support bracket.

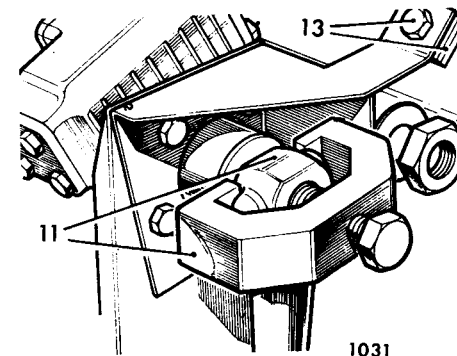
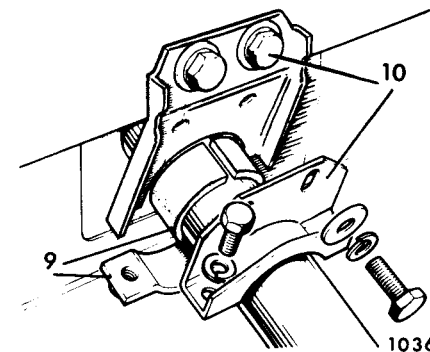

continued

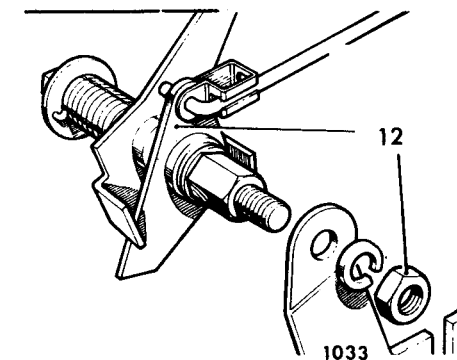

- 13 Remove the fixings, steering box stiffener bracket to the toe box.
- 14 Raise the front of the vehicle and support on stands.
- 15 Remove the front road wheel, fitted to the steering side of the vehicle.
- 16 Remove the steering unit cover box from the wheel arch.
- 17 Remove the fixings, steering box support bracket to toe box, wing valance and chassis.
- 18 Withdraw the steering column and box assembly complete with attached brackets from beneath the front wing.
- 19 If required, remove the stiffener bracket and support bracket from the steering box.

NOTE: The steering box can be overhauled without removing the brackets.

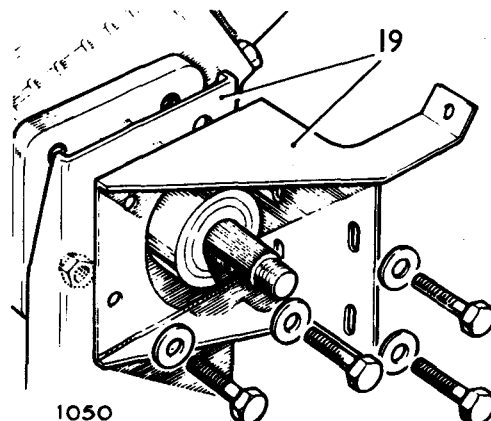
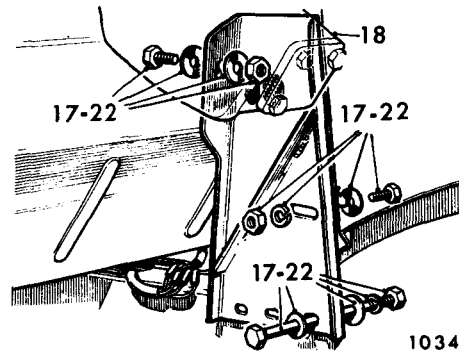
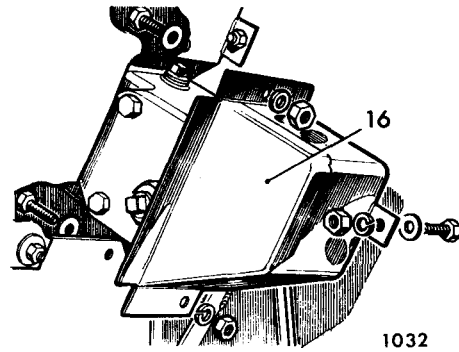

Refitting

- 20 If removed, fit the support bracket and stiffener brackets to the steering box. Torque 7,0 to 8,5 kgf. m (50 to 60 lbf. ft.).
- 21 Locate the steering box and bracket assembly, less drop arm, in position on the vehicle.
- 22 Retain the support bracket to the chassis, wing valance and toe box, but do not fully tighten the fixings at this stage.
- 23 Retain the steering box stiffener bracket to the toe box, but do not fully tighten the fixings at this stage. If necessary, fit shim washers between the stiffener bracket and the toe box to prevent distorting the toe box or bracket.
- 24 Reverse instructions 9 and 10.

CAUTION: DO NOT strain the steering column. If necessary, adjust the steering box position, using the slotted fixing holes in the support and stiffener brackets, to obtain a snug fit between the clamp upper half and the steering column, before securing the clamp halves.

- 25 L.H. stg. models – insert slotted packing pieces, as required, to take up clearance between support bracket and the toe box.
- 26 R.H. stg. models – insert slotted packing pieces, as required, to take up clearance between the support bracket and stiffener bracket and the toe box.
- 27 Secure the support bracket and stiffener bracket fixings. Torque load for support bracket to chassis fixings is 2,0 kgf. m (15 lbf. ft.).
- 28 Reverse instructions 4 to 13.
- 29 Set the steering box in its mid-position, that is, at the middle of its travel between left hand and right hand locks.
- 30 Set the front wheels in the straight ahead position.
- 31 Engage the drop arm on the steering box splines.
- 32 Fit the lock plate and nut. Nut torque, 8,5 to 11 kgf. m (60 to 80 lbf. ft.).
- 33 Bend over the lock plate.
- 34 Reverse instructions 1 to 3.

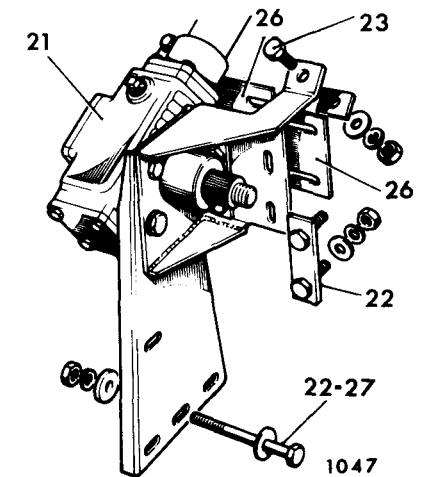
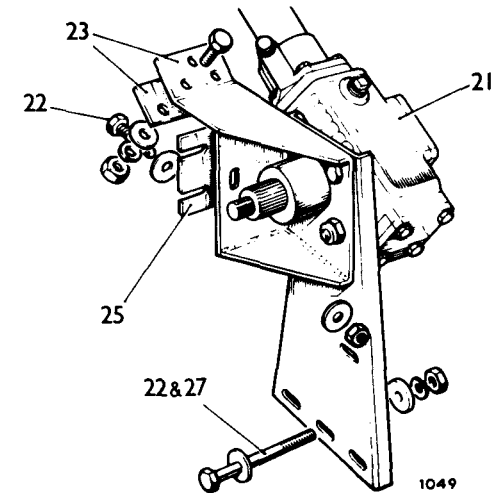

STEERING COLUMN AND BOX ASSEMBLY

Overhaul

57.45.07

- 1 Remove the steering column and box assembly from the vehicle. 57.45.01.
- 2 Remove the side cover and gasket and drain the oil from the steering box.
- 3 Rotate the inner steering column to locate the main nut and recirculating tube in its mid-position on the steering worm. Remove the roller for the main nut and the rocker shaft.
- 4 Remove the four bolts securing the steering column flange to the steering box. Removal of the column pinch bolt will facilitate access.
- 5 Withdraw the outer steering column, flange and gasket.
- 6 Gently jerk the inner steering column to extract the steering box upper bearing track and balls (10). Ensure the balls do not spill out when the track is released from the box.
- 7 Rotate the steering worm to release the main nut and recirculating tube.
- 8 Withdraw the main nut and recirculating tube and balls (12).
- 9 Withdraw the steering worm and inner column assembly.
- 10 Remove the four bolts securing the end plate.
- 11 Remove the end plate and shims.
- 12 Remove the lower bearing track and balls (10).
- 13 Remove the rocker shaft oil seal retaining washer and oil seal.
- 14 If rocker shaft bush renewal is intended, remove the bush.
- 15 If outer column top bearing renewal is intended, remove the bearing.

Inspecting

- 16 Thoroughly clean and examine all components for wear or damage. Renew components as necessary. Wear in components is cumulative when related to steering wheel backlash.

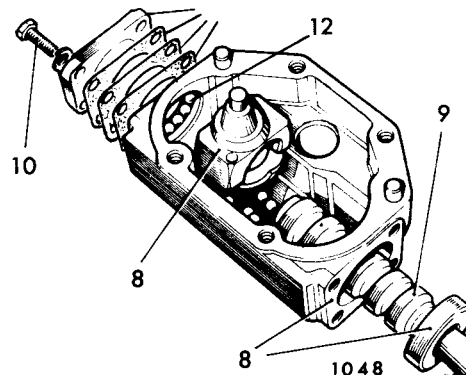
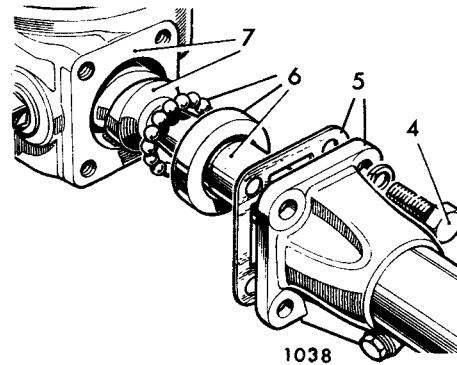
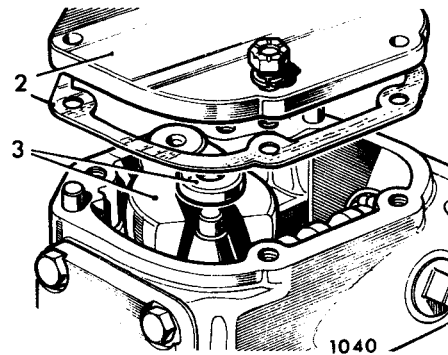

Assembling

- 17 Fit the top bearing (if removed) to the outer column.
- 18 Fit a new rocker shaft bush (if required).
- 19 Fit the rocker shaft oil seal and retaining washer. Stake the washer.
- 20 Enter the steering worm in the steering box.
- 21 Liberally coat the inner surfaces of the main nut and recirculating tube with grease. Install the balls (12).
- 22 Rotate the steering worm and engage the main nut and recirculating tube ensuring that the balls are not dislodged. Locate the main nut in mid-position in the worm.
- 23 Thoroughly coat the upper and lower bearing tracks with grease. Fit the balls, ten to each bearing track.
- 24 Slide the upper bearing track over the inner steering column and locate the track in the steering box.
- 25 Engage the worm in the bearing track ensuring that the balls are not dislodged.
- 26 Fit the gasket and outer steering column. Note that the column pinch bolt must be adjacent to the steering box filler plug.
- 27 Fit the four bolts to the column flange using Wellseal on the bolt threads.
- 28 Fit the lower bearing track to the steering box ensuring that the balls do not become dislodged.
- 29 Fit the bottom cover and shim pack and secure with the four bolts. Use Wellseal on the bolt threads.
- 30 Check the inner column and worm for freedom of rotation and end-float. There must be an end-float of 2 to 4 lb ins. combined with free rotation of the worm. Adjust by adding or removing shims as required.
- 31 Fit the rocker shaft and the roller for the main nut.
- 32 Slacken the side cover locknut and adjusting screw.
- 33 Fit the side cover and gasket. Apply Wellseal to the securing bolt threads. Fit the bolts and evenly tighten.

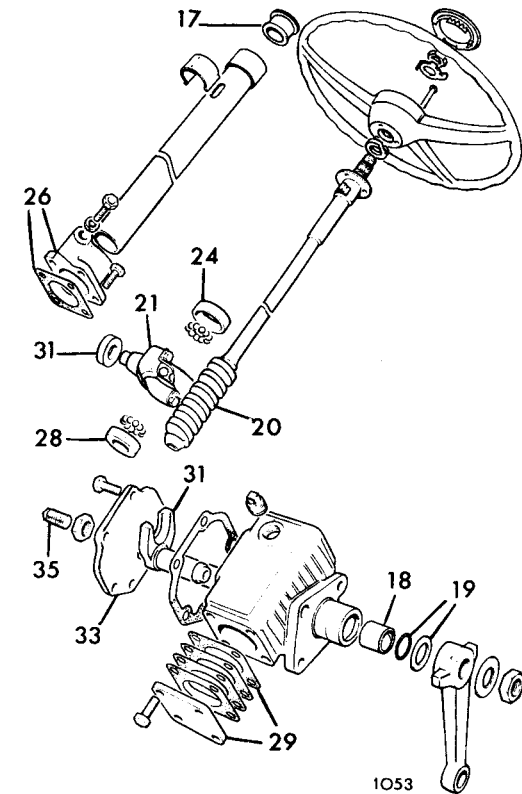

- 34 Fill the steering box with fresh oil.
- 35 With the rocker shaft in the mid-position of its travel tighten the adjuster screw to provide a torque at the steering wheel of 10 to 14 lb ins. Do not impose load on the rocker shaft. Tighten the adjusting screw locknut.
- 36 Fit the steering column and box assembly to the vehicle. 57.45.01.

STEERING RELAY

Remove and refit

57.50.02

Removing

- 1 Remove the radiator grille.
- 2 Remove the relay guard bracket.
- 3 Remove from above the relay assembly all fittings which would prevent removal of the relay assembly, e.g. 88 RHD models. The horn, battery, battery box and air cleaner.
- 4 Remove the nut and bolt securing the relay upper lever.
- 5 Detach the upper lever from the relay shaft.
- 6 Remove the nut and bolt securing the relay lower lever.
- 7 Detach the lower lever from the relay shaft.
- 8 Remove the two upper bolts and spring washers securing the relay to the chassis.
- 9 Remove the four bolts and spring washers securing the relay lower flange plate to the chassis. Remove the flange plate.
- 10 Drift the relay assembly upward to release it from the chassis. Care must be taken to avoid damaging the relay shaft splines.

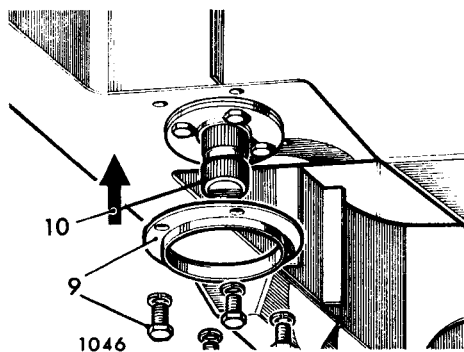
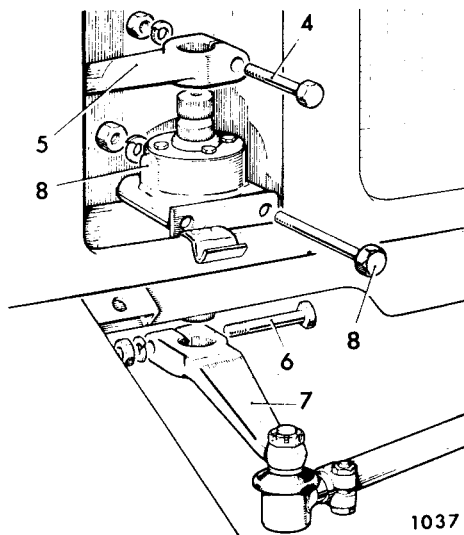

Refitting

- 11 Ensure that the relay unit is filled with oil.
- 12 Check that the relay location in the chassis is clean. Smear the location hole with grease.
- 13 Insert the relay assembly in the chassis and drift into position. Ensure that the cast projection on the upper side of the relay housing is fitted to the driver's side of the vehicle.
- 14 Fit the lower flange and its four securing bolts.
- 15 Fit the two upper bolts and nuts securing the relay housing to the chassis.

- 16 Fit the upper and lower relay levers and their respective securing bolts and nuts. The angular relationship of the upper and lower relay levers should be 81° . This can be checked by setting the road wheels in the straight ahead position, at which point the relay lower lever should be at 90° to the track rod. The relay upper lever should be inclined forward of the track rod, 9° out of alignment with the track rod.
- 17 Fit the relay guard bracket.
- 18 Fit the components removed to permit withdrawal of the relay housing.
- 19 Fit the radiator grille.

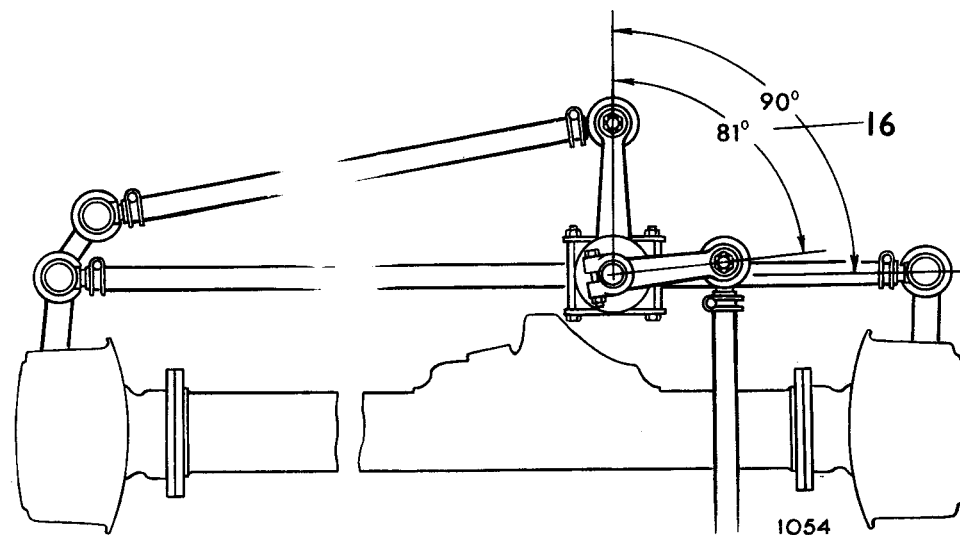

STEERING RELAY

Overhaul

57.50.08

Service tool: 600536 spring compressor.

- 1 Remove the relay assembly from the vehicle. 57.50.02.

Dismantling

- 2 Remove two of the securing bolts from the relay top cover. Invert the relay and allow the oil to drain.
- 3 Locate the relay assembly horizontally in a vice.
- 4 Remove the four bolts securing the relay lower cover.

NOTE: Illustration 'A' shows the early seal and housing arrangement and Illustration 'B' is the latest condition.

- 5 Remove the lower cover complete with oil seal, gasket and thrust washer. Discard the gasket.
- 6 The relay shaft now has to be drifted through the lower end of the relay housing. Refer to the sectioned illustration of the relay assembly. Note that items 'A' are split bushes with an internal tapered face, against which they are held by a compression spring.

WARNING: The relay split bushes and spring will fly apart when released from the housing. Protection must be provided to prevent injury.

Enclose the lower end of the relay assembly with stout material leaving within the material sufficient space to accommodate the relay shaft. Secure the material to the relay housing to form a safety sheath.

- 7 Gently tap the relay shaft into the safety sheath.
- 8 Remove the safety sheath and collect the relay shaft, split bushes, spring and washers.
- 9 Remove the bolts securing the relay upper cover and remove the upper cover complete with oil seal, gasket and thrust washer. Discard the gasket. Remove the oil seal.
- 10 Remove the oil seal from the relay lower cover.

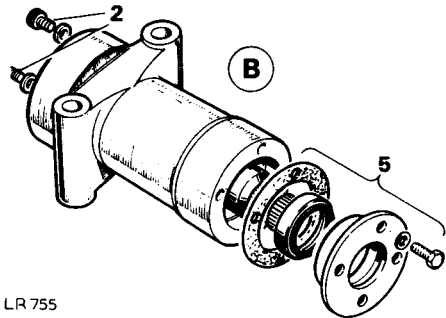
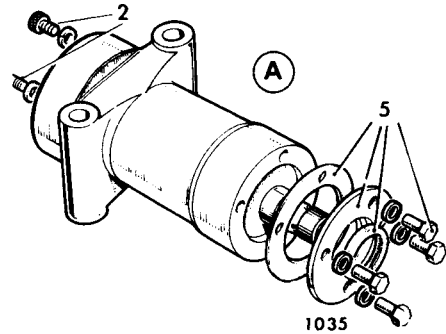

LR 755

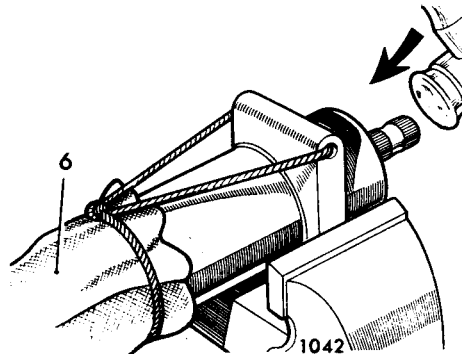

Inspecting

- 11 Thoroughly clean all components and examine for wear and damage. Renew components as necessary. The free length of the spring should be 170 to 184 mm (6.750 to 7.250 in.).

Assembling

- 12 Apply jointing compound to the outer periphery of the new oil seals. Fit the oil seals to the relay upper and lower covers (seal lips towards relay housing).
- 13 Locate two halves of the split bush on the top cone of the shaft.
- 14 Insert the assembly of shaft and bush into the housing from the bottom.
- 15 Secure the housing and shaft assembly, bottom end uppermost, in a vice with a 19 mm (0.750 in.) support block under the bottom end of the shaft.
- 16 Insert washer for spring into housing and fit two of the oil seal retainer fixing bolts into the housing diametrically opposite each other.
- 17 Fit the spring and washer.
- 18 Using Service tool 600536, carefully compress the spring.
- 19 Turn the tool to lock in position with the keyhole slots under the heads of the bolts.
- 20 Locate the other split bush in position on the bottom cone of the shaft and secure with a 50 mm (2 in.) hose clip.
- 21 Remove the service tool and the seal retainer fixing bolts.

continued

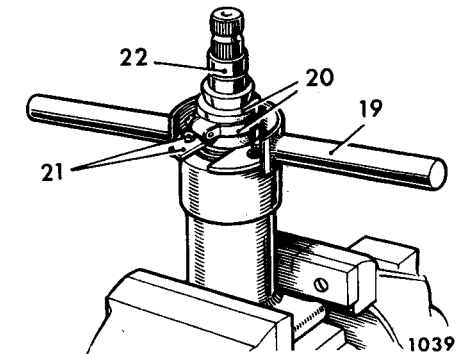
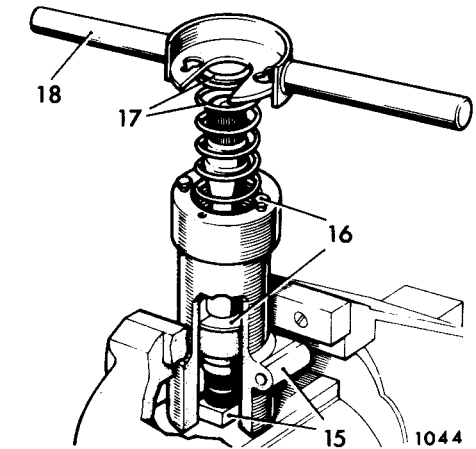
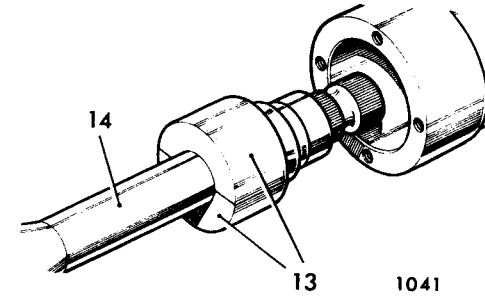
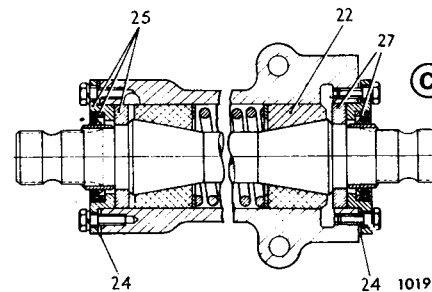

NOTE: Cross-section 'C' is the early relay. Illustration 'D' is the latest assembly.

- 22 Remove the assembly from the vice, gently tap shaft into position until the split bush has entered the housing for at least half its length.
- 23 Remove the hose clip and continue to tap the shaft into the housing until the bushes are correctly located in the housing.
- 24 Smear general purpose grease on both sides of the joint washers and fit one to each end of the housing.
- 25 Fit the thrust washer and end cover, complete with seal, to bottom end of the housing only. Use 'Wellseal' or suitable equivalent sealing compound on the threads of the bolt fitted to the breather hole.
- 26 Fill the housing with the correct grade oil.
- 27 Fit the thrust washer and end cover, complete with seal to the top of the housing, using sealing compound on the threads of the four securing bolts.
- 28 Hold the relay unit in a vice.
- 29 Temporarily attach the upper relay lever and use a suitable spring balance to check resistance to rotation of the relay shaft. The resistance, measured on the spring balance, must not be less than 6,8 kg. (15 lb.) and should not exceed 12,2 kg. (27 lb.).
If the resistance is less than 5,4 kg. (12 lb.), fit a new spring.
If the resistance is excessive, remove the oil seal retainers and thrust washers, then use a suitable piece of tube to push each split bush in turn, clear of its cone and inject lubricating oil. Reassemble and recheck.
- 30 Fit the relay assembly to the vehicle. 57.50.02.

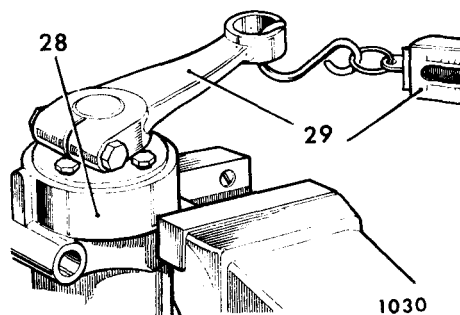
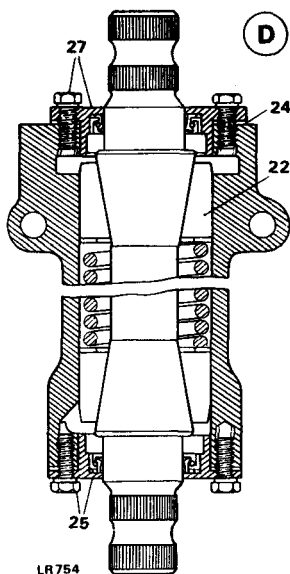

DATA

Relay spring free length	170 to 184 mm (6.750 to 7.250 in)
Resistance to rotation, relay shaft	6,8 to 12,2 kg (15 to 27 lb) measured using a spring balance

TRACK ROD BALL JOINTS

Remove and refit, instructions 6 to 9
57.55.08

TRACK ROD

Remove and refit, instructions 1 to 5
and 10 to 14
57.55.09

Service tool: 601763, Ball joint extractor

Removing, track rod

- 1 Jack up the vehicle front end and support on stands.
- 2 Remove the front road wheels.
- 3 Remove the fixings from both ball joints.
- 4 Extract the ball joints, using 601763.
- 5 Withdraw the track rod and ball joints.

Removing, ball joints

- 6 Slacken the ball joints clamp fixings.
- 7 Unscrew the ball joints, L.H. and R.H. thread.

Refitting, ball joints

- 8 Screw the ball joints equally until the overall dimension between the ball joint centres is 1030,3 to 1033,4 mm (45.56 to 45.68 in.).
- 9 Position the ball joint clamps 1,58 to 3,17 mm (0.062 to 0.125 in.) from the track rod ends do not tighten the clamp bolts at this stage.

continued

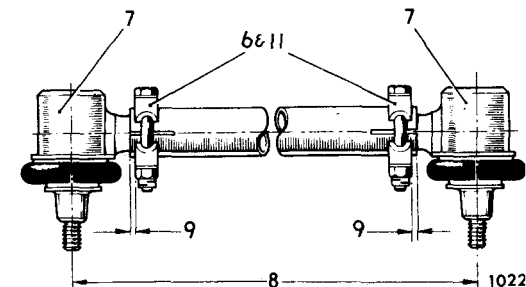
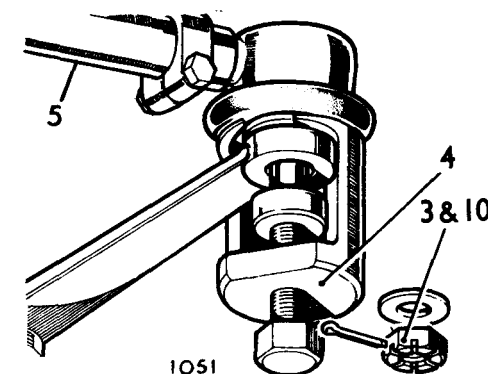

Refitting track rod

- 10 Reverse instructions 3 to 5. Torque for ball joint fixings 4,0 kgf. m (30 lbf. ft.)
- 11 Check and if necessary adjust the wheel alignment 57.65.01 leaving the clamp fixings slackened.
- 12 Lightly tap the ball joint cups in the direction illustrated to the maximum of their travel to ensure full unrestricted movement of the track rod.
- 13 Tighten the ball joint clamps. Torque load 1,1 to 1,5 kgf. m (8.5 to 10.5 lbf. ft.).
- 14 Reverse instructions 1 and 2.

109 1 ton models are fitted with a two piece track rod. Note that the cranked member must be fitted to provide maximum clearance for the front axle differential housing.

DATA

Initial setting dimension for track rod and ball joints

Position of ball joint clamps

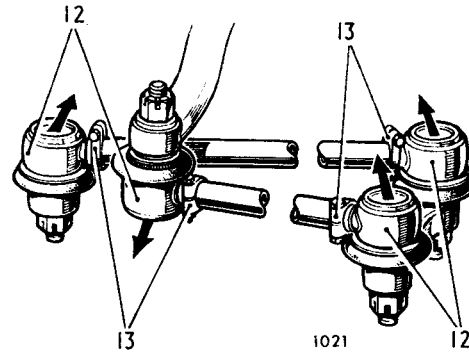

1157 to 1160 mm (45.68 in.)
measured between ball joint centres
1,6 to 3,2 mm (0.062 to 0.125 in.)
from track rod ends

**LONGITUDINAL STEERING
TUBE BALL JOINTS**

Remove and refit, instructions 9 to 12
57.55.12

**LONGITUDINAL STEERING
TUBE**

Remove and refit, instructions 1 to 8
and 13 to 19
57.55.13

Service tool: 601763, Ball joint extractor

Removing

- 1 Remove the bonnet panel.
- 2 If required for access, remove the air cleaner.
- 3 Remove the radiator grille.
- 4 Remove the fixings securing the upper relay lever to the relay unit and prise the lever clear.
- 5 Remove the fixings from the ball joint connecting the longitudinal arm to the steering box drop arm.
- 6 Using service tool 601763 extract the ball joint from the steering box drop arm.

NOTE: LH stg. models — It may be necessary to remove the exhaust manifold to provide access for the ball joint extractor.

- 7 Manoeuvre the end of the upper relay lever through the aperture in the grille panel, then, moving the steering box drop arm fully forward, carefully withdraw the upper relay lever and longitudinal arm assembly.
- 8 Remove the fixings and extract the ball joint from the upper relay lever, using 601763.

continued

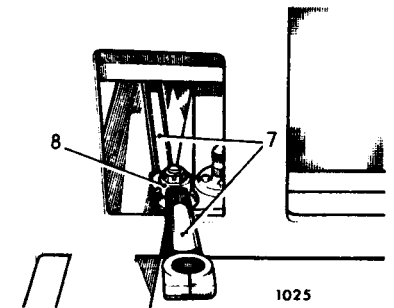
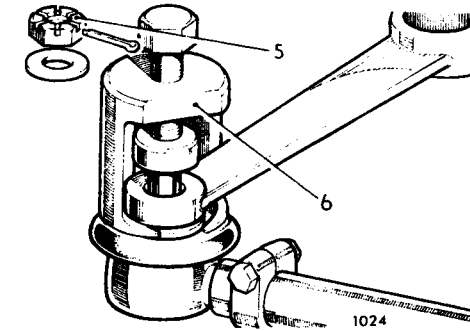
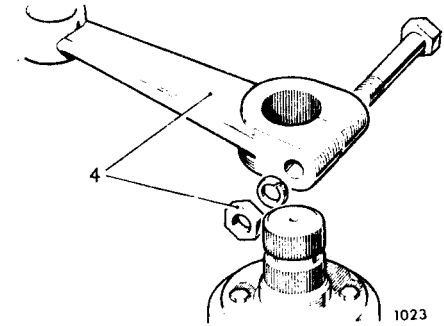

Removing ball joints

- Slacken the ball joint clamp fixings.
- Unscrew the ball joints, LH and RH thread.

Refitting ball joints.

- Screw in the ball joints equally until the overall dimension between ball joint centres is 621,4 to 624,6 mm (24.46 to 24.59 in.).
- Position the clamps 1,58 to 3,17 mm (0.062 to 0.125 in.) from the longitudinal tube ends; do not tighten the clamp fixings at this stage.

Refitting the longitudinal tube.

- Reverse instructions 5 to 8. Torque load for ball joint fixings is 4,0 kgf. m (30 lbf. ft.).
- Place the front wheels in the straight ahead position and the steering wheel in the intermediate position, then connect the upper relay lever to the relay unit, the longitudinal arm may require adjusting slightly to align the splines of the relay lever and unit.
- Tighten the lever pinch bolt. Torque 7,6 kgf. m (55 lbf. ft.).
- Using a mallet, lightly tap the ball joint cups in the direction indicated to the maximum of their travel, to ensure full unrestricted movement of the longitudinal arm.
- Secure both ball joint clamps. Torque load 1,1 to 1,5 kgf. m (8.5 to 10.5 lbf. ft.).
- Check the steering lock stops setting. 57.65.03.
- Check the steering, lock-to-lock, for correct functioning. If necessary, adjust the overall length of the longitudinal arm by slackening the ball joint clamps and screwing the arm in or out, as required, then resecure the clamps.

DATA

Initial setting dimension for longitudinal tube and ball joints

Position of ball joint clamps

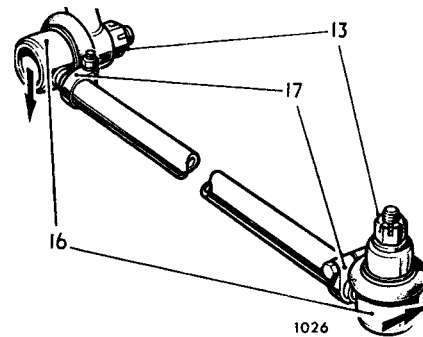
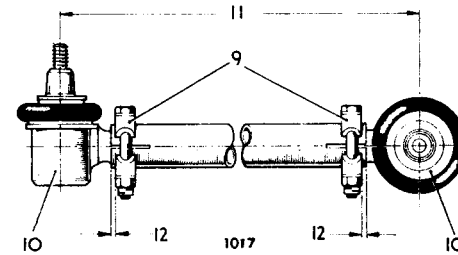

621,4 to 624,6 mm (24.46 to 24.59 in.)
measured between ball joint centres
1,6 to 3,2 mm (0.062 to 0.125 in.)
from tube ends

DRAG LINK BALL JOINTS

Remove and refit, instructions 6 to 9
57.55.16

DRAG LINK

Remove and refit, instructions 1 to 5
and 10 to 13
57.55.17

Service tool: 601763, Ball joint extractor

Removing, drag link

- Jack up the vehicle front end.
- Remove the front road wheel from the side where the drag link is connected to the swivel pin steering lever.
- Remove both drag link ball joint fixings.
- Extract the ball joints, using 601763.
- Withdraw the drag link and ball joints.

Ball joints, removing

- Slacken the clamp fixings.
- Unscrew the ball joints, L.H. and R.H. thread.

Ball joints, refitting.

- Screw in the ball joints equally until the overall dimension between ball joint centres is 782,62 to 785,79 mm (30.812 to 30.937 in.).
- Position the clamps 1,58 to 3,17 mm (0.062 to 0.125 in.) from the drag link ends. Do not tighten the clamp fixings at this stage.

continued

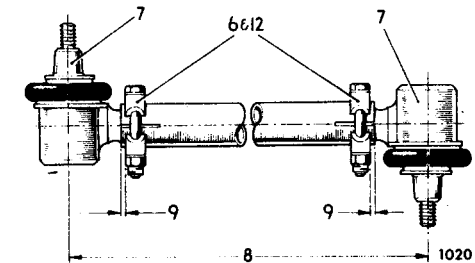
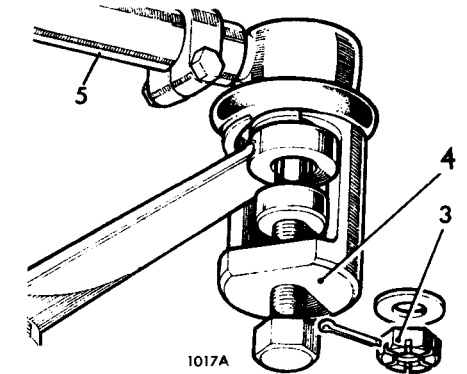

Refitting, drag link

- 10 Reverse instructions 3 to 6. Torque for ball joint fixings 4,0 kgf. m (30 lbf. ft.).
- 11 If the clamps were previously slackened, lightly tap the ball joint cups in the direction indicated to the maximum of their travel, to ensure full unrestricted movement of the drag link using a mallet.
- 12 Tighten the ball joint clamps. Torque load 1,1 to 1,5 kgf. m (8.5 to 10.5 lbf. ft.).
- 13 Reverse instructions 1 and 2.

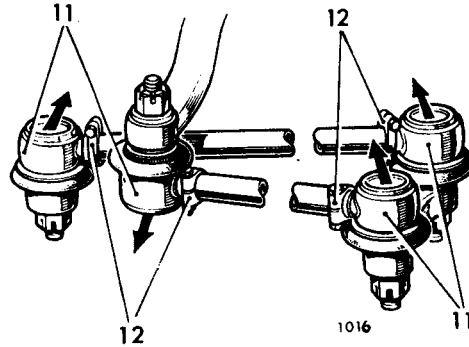

DATA

Initial setting dimension for drag and ball joints

Position of ball joint clamps

782,62 to 785,79 mm (30.812 to 30.937 in.) measured between ball joint centres.
1,58 to 3,17 mm (0.062 to 0.125 in.) from drag link ends.

STEERING WHEEL

Remove and refit 57.60.01

Removing

- 1 Set the road wheels to the straight ahead position.
- 2 Remove the steering wheel centre cover.
- 3 Release the lock tab from the steering wheel nut.
- 4 Remove the steering wheel nut and lock washer.
- 5 Withdraw the steering wheel.

Refitting

- 6 Check that the direction indicator cam and double spring washer are in position on the steering column.
- 7 Engage the steering wheel on the column splines (road wheels straight ahead, centre spoke of steering wheel towards driver).
- 8 Ensure that the direction indicator cam engages the steering wheel.
- 9 Fit the lock washer and steering wheel nut.
- 10 Tighten the nut and secure with lock washer tab.
- 11 Fit the centre cover.

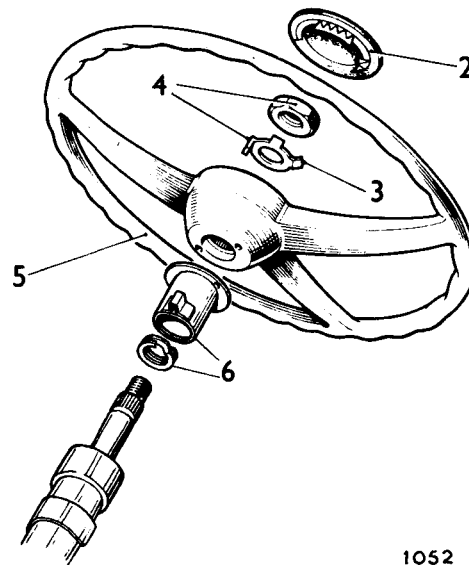

1052

FRONT WHEEL ALIGNMENT

Check and adjust 57.65.01

Checking

- 1 Set the vehicle on level ground with the road wheels in the straight ahead position, and push it forward a short distance.
- 2 Measure the toe-in with the aid of a tracking stick or suitable proprietary equipment; it should be 1,2 mm to 2,4 mm (3/64 to 3/32 in.) measured at the horizontal centre-line of the road wheels.
- 3 If necessary, adjust the toe-in as follows:

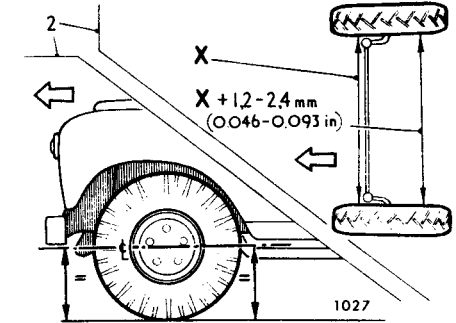

1027

Adjusting

- 4 Slacken the clamps securing the ball joint at each end of the track rod.
- 5 Turn the track rod to decrease or increase its effective length as necessary, until the toe-in is correct.
- 6 Push the vehicle rearwards turning the steering wheel from side to side to settle the ball joints. Then, with the road wheels in the straight ahead position, push the vehicle forward a short distance.
- 7 Recheck the toe-in. If necessary carry out further adjustment.
- 8 When the toe-in is correct, lightly tap the track rod ball joints in the direction indicated to the maximum of their travel, to ensure full unrestricted movement of the track rod.
- 9 Secure the ball joint clamps. Torque load 1,1 to 1,5 kgf. m (8.5 to 10.5 lbf. ft.).

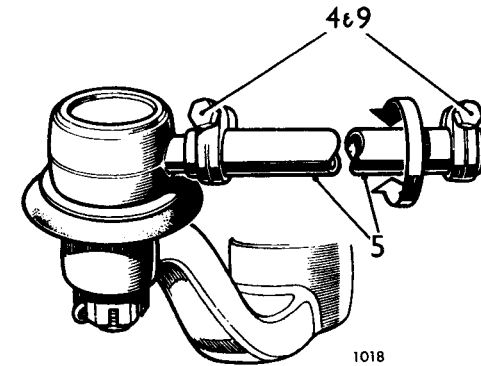

1018

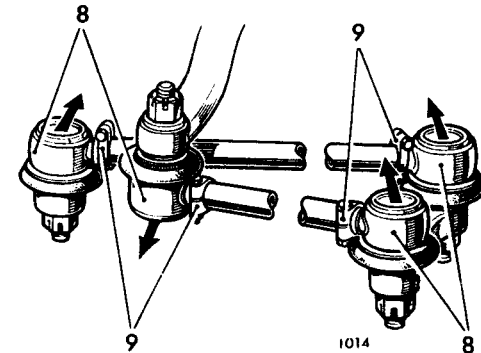

1014

DATA

Front wheel toe-in

1,2 to 2,4 mm (3/64 to 3/32 in.) measured at the horizontal centre-line of the road wheels.

STEERING GEOMETRY

Check 57.65.02

General

No adjustment is provided for castor, camber or swivel pin inclination. For front wheel alignment (toe-in) refer operation 57.65.01.

It is essential that there is equal thread engagement of all steering tube ends (ball joints).

With the road wheels in the straight ahead position and the steering wheel centralised the steering column lock should engage within + or - 20°.

Steering box movement exceeds that required to obtain full lock to lock steering movement. This excess movement must be evenly divided between right hand and left hand locks and must not be less than 90° steering wheel movement before the stops in the steering box are operative. This adjustment must be made in the drag link only.

DATA

Vehicles in static unladen condition with coolant, oils and 22,7 litres (5 Imperial gallons) of fuel, tyres at recommended pressures.

Castor angle	3°
Camber angle	1° 3'
Swivel pin inclination	7°
Front wheel toe-in	1,2 to 2,4 mm (3/64 to 3/32 in.)

LOCK STOPS

Check and adjust 57.65.03

Procedure

- 1 Check that the length of the stop bolt (bolt head to swivel housing) is 12,5 mm (0.50 in.).
- 2 Slacken the locknut and adjust bolt length as necessary. Tighten the locknut.
- 3 Check the steering at full lock and ensure that clearance exists between the tyres and chassis components.

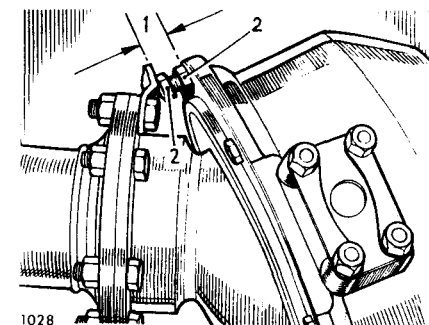

SWIVEL PIN HOUSING ASSEMBLY

Remove and refit

60.15.20

Service tool. 601763. Ball joint extractor.

Removing

- 1 Remove the front hub. 60.25.01.
- 2 Remove the front stub axle. 60.25.22.
- 3 Withdraw the half shaft.
- 4 Disconnect the track rod at the track arm; tool 601763. If the swivel housing to be removed is fitted to the steering box side of the vehicle disconnect the drag link.
- 5 Remove the bolts and nuts securing the inner flange of the swivel housing assembly to the axle flange. Note the location of the steering stop bracket, and, on the right hand flange only, the position of the jack location stop bracket.
- 6 Remove the swivel pin housing assembly.
- 7 Remove and discard the inner flange gasket.

Refitting

- 8 Reverse instructions 1 to 7. Torque — track rod end nut 4,0 kfg. m (30 lbf. ft.).

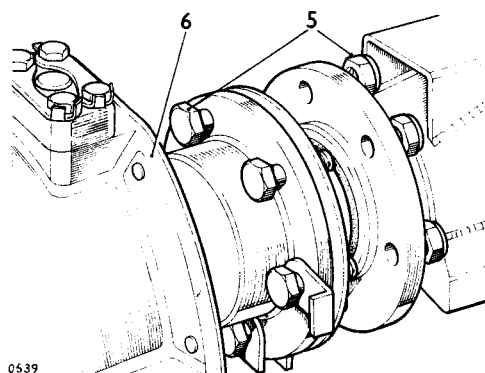
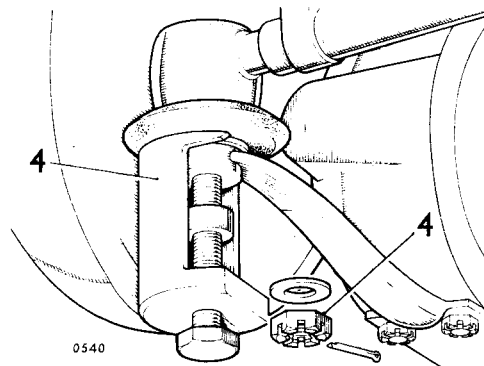

SWIVEL PIN HOUSING ASSEMBLY

Overhaul

60.15.23

- 1 Remove the swivel pin housing assembly from the vehicle 60.15.20

Dismantling

- 2 Remove the bolts, spring and plain washers securing the inboard oil seal cover. Note the position of the steering stop bracket, brake hose bracket, and if the swivel unit is fitted to the right hand side of the vehicle, the position of the jack location plate. Withdraw the oil seal cover.
- 3 Prise out and discard the oil seal.
- 4 Release the lock tabs from the upper swivel pin bolts and remove the bolts and lock plates.
- 5 Withdraw the upper swivel pin and shims.
- 6 Release the lock tabs from the track arm nuts and remove the nuts and lock plates.
- 7 Withdraw the track arm complete with the lower swivel pin. Remove and discard the 'O' ring.
- 8 Separate the swivel pin inner and outer housings.
- 9 Remove the lower swivel pin roller bearing and bearing track.
- 10 Press out the Railko bush housing.
- 11 Remove the half shaft bearing track.

continued

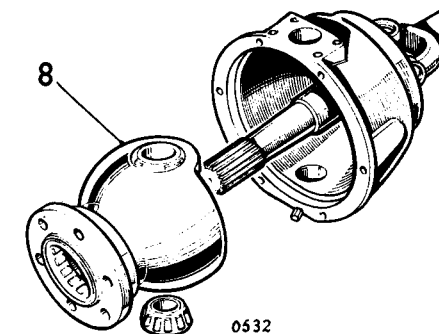
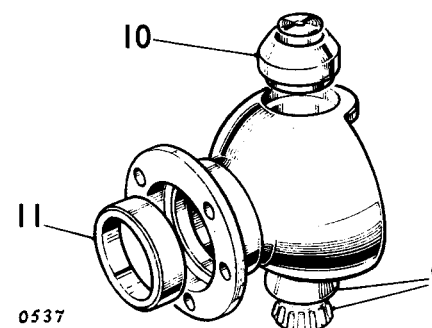
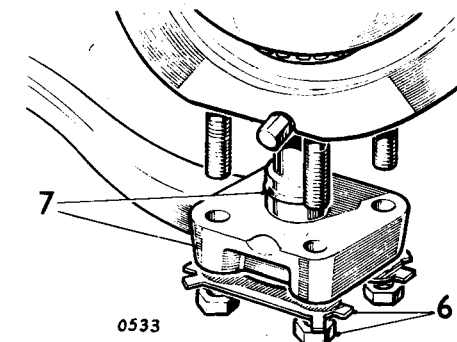
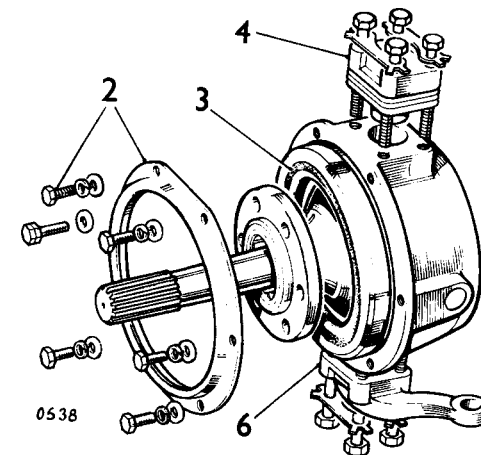

Inspection

- 12 Clean and examine all components for wear and damage. Note that fuel or any cleaning fluid must not be applied to the Railko bush as this would impair the damping characteristics of the bush. Renew all components as necessary.

Assembling

NOTE: If the studs for the track arm have been removed, fit new studs. Coat the short threaded ends of the studs with Loctite 270 and screw them into the swivel housing; torque 5,5 to 6,9 kgf m (40 to 50 lbf ft).

- 13 Using an oil recommended for the swivel pin housing (Refer Division 09) lubricate the Railko bush. Ensure that the thrust disc is in position in the bottom of the bush.
- 14 Fit the Railko bush and housing.
- 15 Fit the lower swivel bearing track and lubricate.
- 16 Fit the half shaft bearing track and lubricate.
- 17 Fit the lower swivel pin roller bearing.
- 18 Fit the inner swivel housing to the outer swivel housing.
- 19 Fit a new 'O' ring to the lower swivel pin/track arm assembly.
- 20 Smear the mating faces of the outer swivel pin housing and lower swivel pin/track arm assembly with Loctite Stud-lock Compound.
- 21 Fit the lower swivel pin/track arm assembly. Ensure that the track arm points to the front of the vehicle.
- 22 Fit the lock plates and nuts. Evenly tighten the nuts. Torque 7,0 to 8,9 kgf. m (50 to 65 lbf. ft.). Bend the lock tabs to secure the nuts.
- 23 Fit the upper swivel pin, original shim(s), lock plates and bolts.
- 24 Evenly tighten the bolts. Torque 7,0 to 8,9 kgf. m (50 to 65 lbf. ft.) but do not bend the lock tabs at this stage.

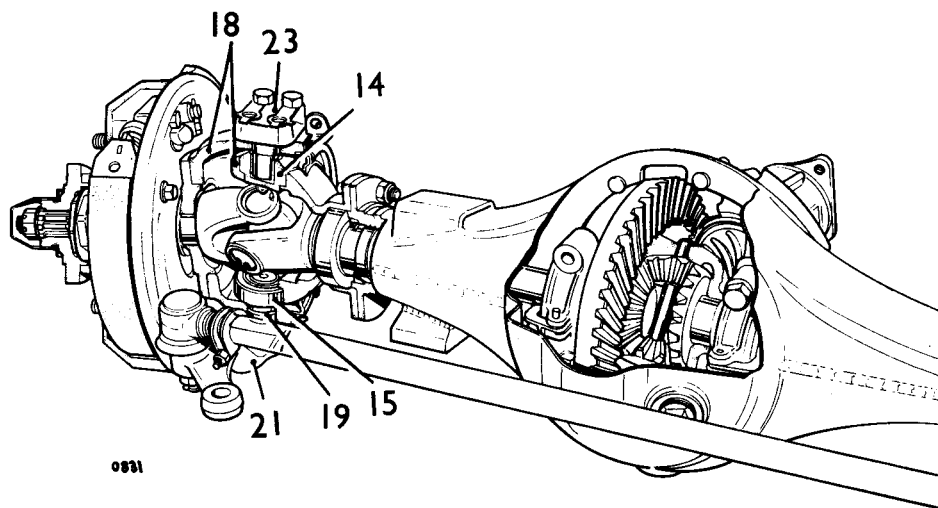
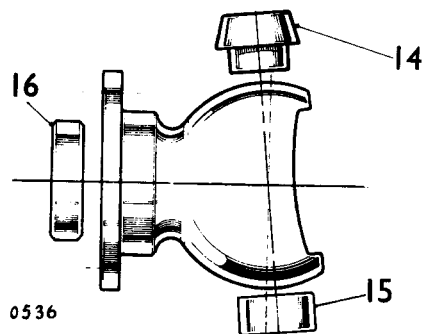

- 25 Using a spring balance attached to the track rod eye check the resistance to swivel pin movement. This should be within 3,6 to 4,5 kg (8 to 10 lb) when the initial inertia load is overcome. Adjust by adding or removing shims at the top swivel as required.
- 26 Engage the lock tabs at the top swivel bolts.
- 27 Pack the inboard seal with heavy grease. Fit the seal to the outer swivel housing.
- 28 Fit the seal retaining ring, brake hose bracket, steering stop bracket and if applicable (RH swivel only), the jack location plate.
- 29 Check that the seal effectively wipes the spherical face of the inner swivel housing. Adjust if necessary by re-positioning the seal retaining ring within the limits of the bolt holes.
- 30 Fit the swivel pin housing assembly to the vehicle. 60.15.20.

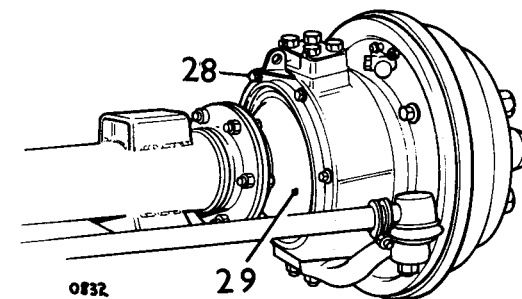
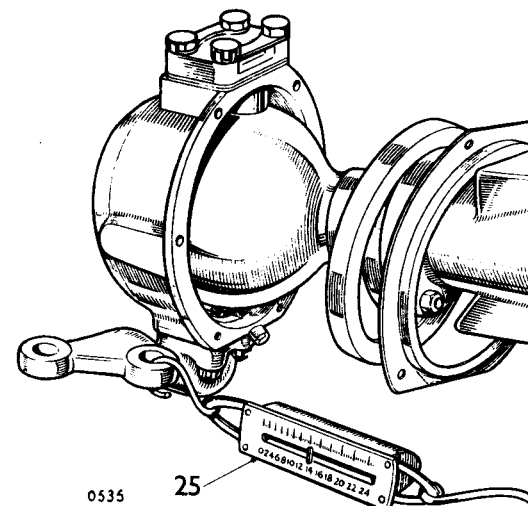

FRONT ROAD SPRING

Remove and refit

60.20.01

Removing

- 1 Front road springs, driver's side and passenger's side, must not be interchanged. A stiffer spring is fitted to the driver's side. Springs can be identified by the increased camber of the spring fitted to the driver's side and by the part number stamped on the underside of the third leaf.
- 2 Jack the vehicle and support the chassis securely.
- 3 Remove the road wheel.
- 4 With the jack positioned under the front axle relieve the road spring of load.
- 5 Remove the road spring 'U' bolts and ease the lower end of the shock absorbers and spring plate clear of the spring.

- 6 Remove the shackle bolt nuts.
- 7 Slacken the rear upper shackle bolt. Note that the rear shackle bolts are screwed to the tapped holes of the inner shackle link.
- 8 Remove the spring shackle bolts.
- 9 Remove the road springs.

Refitting

- 10 Reverse instructions 4 to 9 but do not tighten the shackle bolts or shackle bolt nuts. Ensure that the axle is properly located in the spring centre bolt before fitting and tightening the 'U' bolts to 8,0 kgf m (58 lbf ft).

Spring setting procedure

- 11 The shackle bolts which clamp the centre member of the road spring and hangar bracket bushes must not be tightened until the spring is positioned in the mid-point of its deflection range. This ensures that excessive rotation/shear forces are not imparted to the bush centres. Failure to observe this instruction can adversely affect bush life, especially in off-road conditions which produces large spring deflections.
- 12 Deflect the spring towards the chassis to the required dimension by using a length of chain passed over the chassis and under a lifting trolley jack. Alternatively, lower the vehicle on its wheels and load the vehicle.
Dimension 'A', 88 in Models, 110,0 to 114,0 mm.
Dimension 'B', 109 in Models, 118,0 to 122,0 mm.
- 13 Tighten the spring shackle bolts and nuts to 8,3 to 9,7 kgf m (60 to 70 lbf ft).

FRONT ROAD SPRING

Overhaul

60.20.07

- 1 Only the main leaf and second leaf are available as spares items. For spring data refer to Section 04, page 13.

Spring eye bushes

- 2 Remove and refit using a press. Spring eye bushes must be located centrally in the spring.

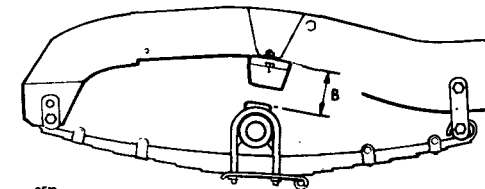
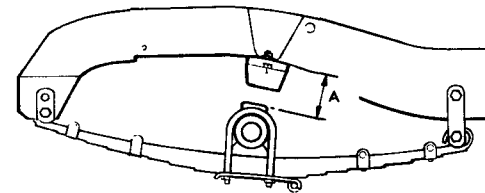
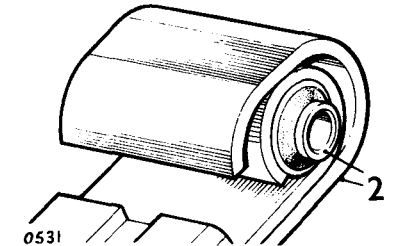
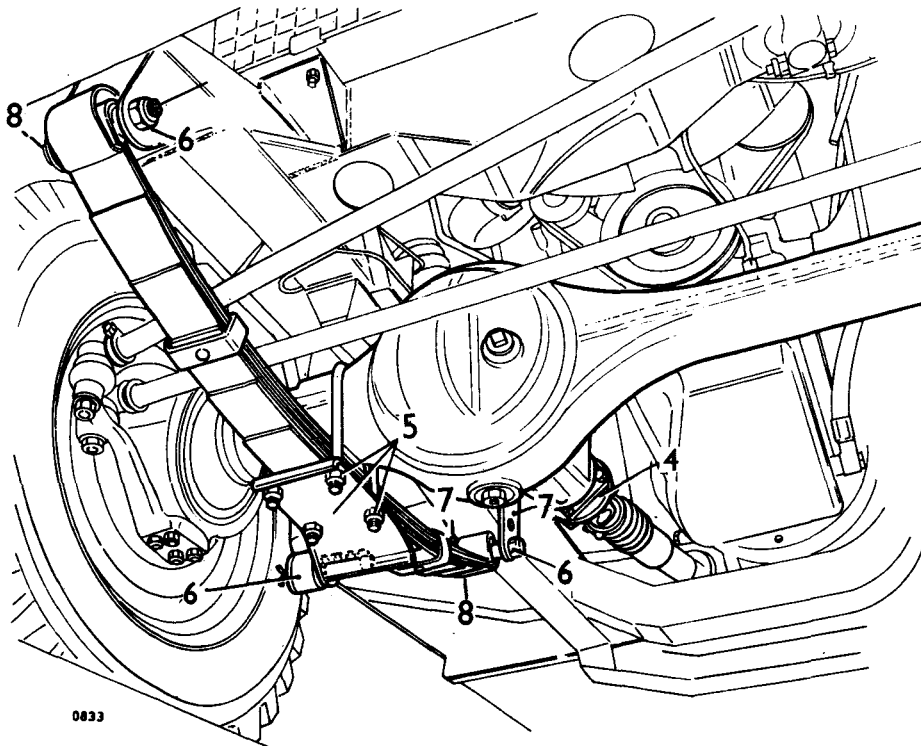

FRONT SPRING HANGAR BRACKET BUSH

Remove and refit 60.20.31

Removing

- 1 Jack up the vehicle and support the chassis securely.
- 2 Remove the road wheel.
- 3 Remove the spring shackle lock nuts.
- 4 Slacken the front and the lower rear shackle bolt.
- 5 Remove the rear, upper shackle bolt and swing the shackle links clear of the chassis.
- 6 Using a drift of suitable dimensions, or, preferably a length of solid drawn tubing and a long bolt and washers extract the bush from the hangar bracket. Where difficulty is experienced and the bush inner member and rubber separates from the bush outer shell, the outer shell may be removed by splitting it with a hack-saw. Care must be taken to avoid marking the hangar bracket.

Refitting

- 7 Clean the hangar bracket bore.
- 8 Using a long bolt and washers pull the new bush into position in the hangar bracket. Ensure it is located centrally in the hangar bracket.
- 9 Fit the rear shackle links and the rear upper shackle bolt but do not tighten at this stage.
- 10 Carry out spring setting procedure, instruction 12 operation 60.20.01.

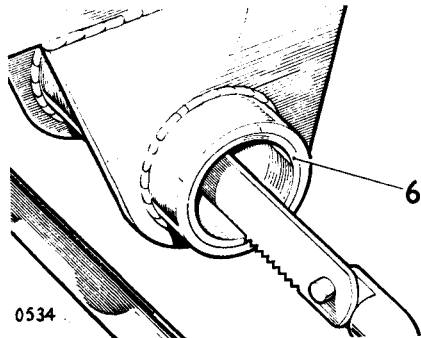

FRONT HUB ASSEMBLY

Remove and refit 60.25.01

Service tool: RO1010. Spanner for half shaft nut. (109 models only).

Removing

- 1 Jack up the vehicle and support securely.
- 2 Remove the road wheel.
- 3 Twist, and slide off the hub cap.
- 4
 - a 88 models. Remove the split pin and hexagon slotted nut securing the drive shaft to the drive flange. Remove the plain washers and sealing washer. Note that the plastic face of the sealing washer is fitted adjacent to the driving flange.
 - b 109 models. Remove the split pin and round slotted nut securing the drive shaft to the drive flange (Tool RO1010). Remove the distance piece and Spirolox ring.
- 5 Remove the bolts and spring washers securing the drive flange to the hub. Withdraw the drive flange and gasket.
- 6 Fully slacken off brake shoe adjustment.
- 7 Remove the brake drum. To facilitate removal, tapped, starter holes are provided.
- 8 Straighten the lock tabs securing the hub nuts.
- 9 Remove the hub lock nut lock washer, adjusting nut and thrust washer.
- 10 Withdraw the hub complete with inner and outer bearings and oil seal.

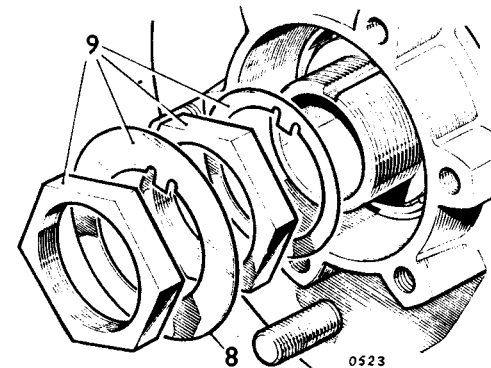
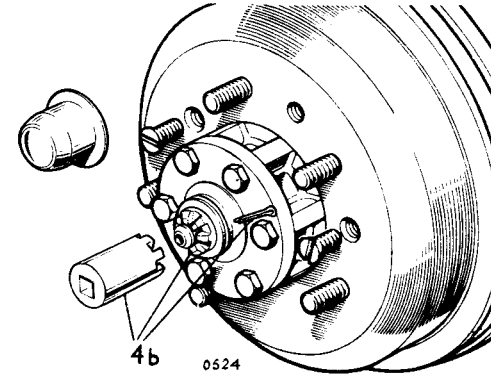
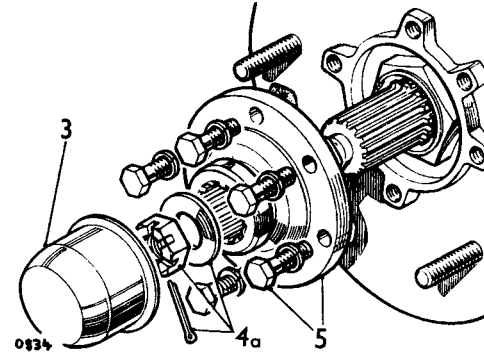

Refitting

- 11 Ensure that the hub is filled to half capacity with fresh grease.
- 12 Install the hub on the stub axle complete with inner and outer bearings and oil seal.
- 13 Fit the tongued washer and adjusting nut.
- 14 Spin the hub to settle the bearings and tighten the adjusting nut sufficient to provide hub end-float of 0,05 to 0,10 mm (0.002 to 0.004 in.). This can be checked using a dial gauge.
- 15 Fit the lock washer and lock nut. Tighten the lock nut. Bend the lock washer to secure both the lock and adjusting nuts. Recheck end-float.
- 16 Reverse instructions 1 to 7.

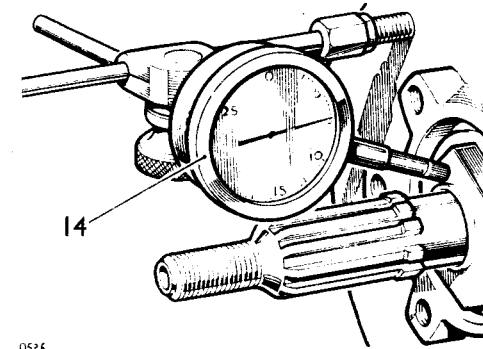

FRONT HUB BEARINGS END-FLOAT

Check and adjust 60.25.13

Checking

- 1 Carry out instructions 1 to 7 operation 60.25.01.
- 2 Using a dial gauge check hub end-float which should be within 0,05 to 0,10 mm (0.002 to 0.004 in.).

Adjusting

- 3 Remove the hub bearing lock nut and lock washer.
- 4 Set the adjusting nut as necessary to obtain the required end-float given in 2 above.
- 5 Fit the lockwasher and locknut.
- 6 Bend the lockwasher to secure both the locknut and the adjusting nut. Recheck end-float.
- 7 Reverse instructions 1 to 7 Operation 60.25.01.

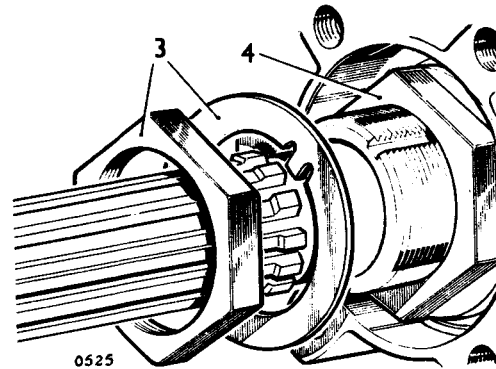

FRONT HUB BEARINGS

Remove and refit 60.25.14

Removing

- 1 Remove the front hub assembly. 60.25.01, instructions 1 to 10.
- 2 Withdraw the outer bearing.
- 3 Remove the inner bearing and oil seal. Discard the oil seal.
- 4 Remove the inner and outer bearing tracks.
- 5 Thoroughly clean the hub and bearings.

Refitting

- 6 Fit the inner and outer bearing tracks.
- 7 Fill the hub to half capacity with fresh grease.
- 8 Fit the inner bearing and a new oil seal. Ensure that the seal lip faces towards the bearing and that the seal lip is lubricated.
- 9 Fit the outer bearing.
- 10 Fit the hub to the stub axle.
- 11 Fit the tongued washer and adjusting nut.

- 12 Adjust hub bearing end-float to within 0,05 to 0,10 mm (0.002 to 0.004 in.).
- 13 Fit the lock washer and lock nut. Bend the lock washer to secure both the lock nut and the adjusting nut.
- 14 Fit the brake drum and adjust the brake shoes.
- 15 Reverse instructions 1 to 5. Operation 60.25.01.

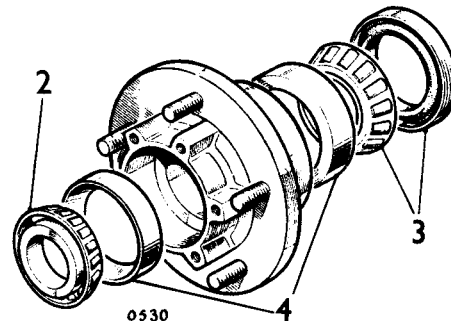

FRONT HUB OIL SEAL

Remove and refit 60.25.15

Removing

- 1 Remove the front hub, instructions 1 to 10. Operation 60.25.01.
- 2 Remove the oil seal and discard.

Refitting

- 3 Fit a new oil seal to the hub, seal lip towards hub inner bearing. Lubricate the seal lip.
- 4 Reverse instructions 1 to 10. Operation 60.25.01.

FRONT HUB STUB AXLE

Remove and refit 60.25.22
Overhaul 60.25.24

Removing

- 1 Remove the front hub, instructions 1 to 10. Operation 60.25.01.
- 2 Disconnect the brake pipe at the wheel cylinder. Plug the wheel cylinder and brake pipe to prevent ingress of foreign matter.
- 3 Remove the bolts securing the brake backplate and stub axle to the swivel housing.
- 4 Detach the brake backplate from the stub axle.
- 5 Remove the stub axle and gasket. Discard the gasket.

Overhaul

- 6 Examine the stub axle for wear and damage. Check the peripheral surface of the distance collar. This area of the collar forms the running surface of the hub oil seal lip. Wear, or ridging will result in rapid oil seal deterioration and ineffectiveness. Renew the collar if necessary. The collar is a press fit on the stub axle.
- 7 Remove the collar by drilling and splitting, taking care to avoid marking or damaging the stub axle.

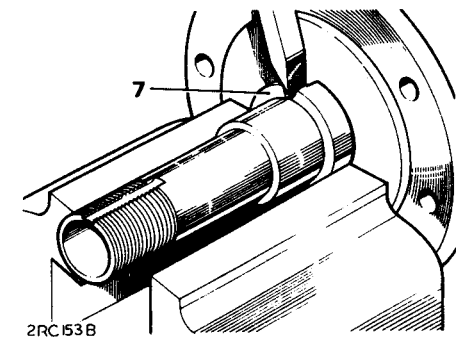
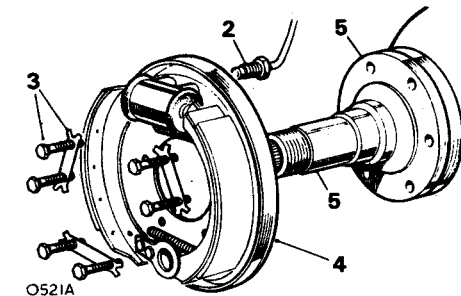

continued

Refitting

- 8 Smear Bostik 772 sealing compound round the radiused corner on the stub axle where the inner bearing distance piece will seat.
- 9 Press on the new distance collar.
- 10 Remove all visible traces of sealing compound.
- 11 Examine the bush inside the stub axle for wear or damage.
- 12 If necessary, fit a new bush. Check the internal diameter after fitting; this should be 31,72 to 31,85 mm (1.249 to 1.254 in).

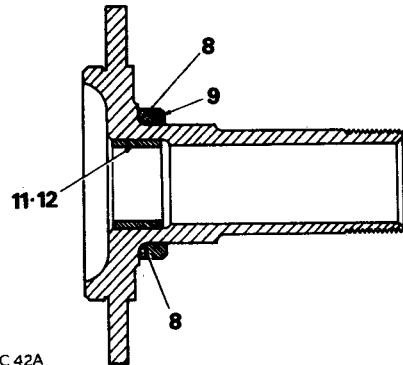

4RC 42A

- 13 Grease and fit a new stub axle flange gasket.
- 14 Coat the threads of the bolts securing the back plate and stub axle to the swivel housing with Loctite 270.
- 15 Reverse instructions 1 to 5.
- 16 Bleed the brakes.

FRONT SHOCK ABSORBER

Remove and refit **60.30.02**

Removing

- 1 Jack up the vehicle and support securely.
- 2 Remove the road wheel.
- 3 Remove the split pin and washer securing the lower end of the shock absorber to the road spring plate.
- 4 Remove the bolt, washer and nut securing the upper end of the shock absorber to the chassis.
- 5 Withdraw the shock absorber complete with bushes.

Checking shock absorber operation.

- 6 Hold the shock absorber vertically in a vice.
- 7 The shock absorber employs differential damping having greater resistance on the extension stroke. Check operation by extending and compressing the shock absorber. Resistance should be uniform throughout the length of each stroke. If resistance is erratic or weak, renew the shock absorber. When checking resistance a new shock absorber may be used for comparison.

Refitting

- 8 Reverse instructions 1 to 5.

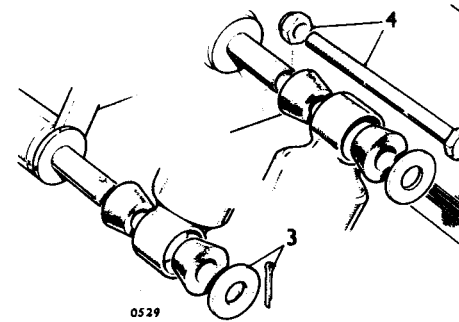

0529

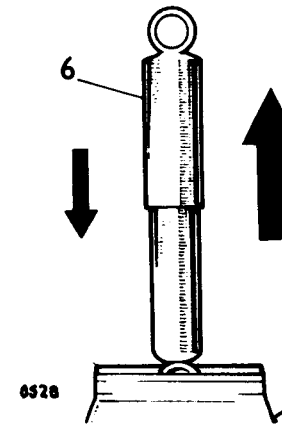

0528

BUMP STOP

Remove and refit **60.30.10**

Removing

- 1 Remove the two bolts, nuts and spring washers securing the bump stop to the chassis.
- 2 Remove the bump stop.

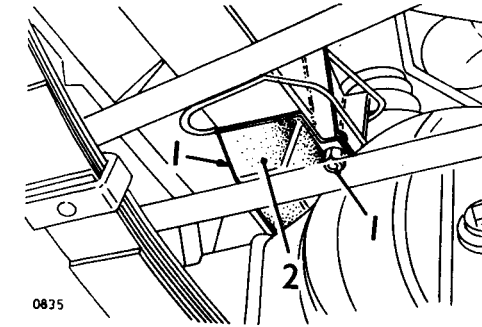

0825

Refitting

- 3 Reverse operations 1 and 2.

SHOCK ABSORBER BUSHES

Remove and refit **60.30.07**

As instructions 1 to 5. Operation 60.30.02.

SUPPLEMENTARY INFORMATION FOR FRONT AND REAR AXLES

Axle rationalization

To reduce the number of axle variants modifications have been made to the existing Land-Rover axle hubs, operations for which are included in the 'FRONT SUSPENSION' and 'REAR SUSPENSION' sections. The following information gives details of the modification and the different overhaul procedures.

The following parts are new:

Intermediate front axle shaft seal.
Dual lip hub seal.
Oil catcher (except 88 in Land-Rover rear axle).
Taper roller bearings.

The following parts are common to all NEW axles front and rear.

Hub assembly.
Hub driving member.
Taper roller bearings.
Dual lip seal.
Hub nut cap.
Hub cap 'O' ring.
Locknuts and locking washers.
Stub axles and bearing sleeves.
Oil catcher.

Axle identification

The new axles can be identified by changes in the axle Serial number suffixes as follows:

88 in Land-Rover front axle from F to G.
109 in Land-Rover front axle from E to G.
88 in Land-Rover rear axle from E to F.

Where the new axles are fitted

- 1 The 88 in and 109 in Land-Rover have the same front axle, the 88 in being uprated to the 109 in specification. Both are fitted with a Rover differential and 11 in (280 mm) diameter brake drums with twin leading shoes. Oil catchers are also fitted. The hub assembly is retained on the drive shaft with a castle nut and split pin.
- 2 The 88 in Land-Rover rear axle is the same as that fitted to the 109 in vehicle except that the differential is of Land-Rover manufacture instead of Salisbury. The brake drums are 10 in (254 mm) diameter. No oil catcher is fitted.
- 3 The 109 in Land-Rover rear axle is the same as the 88 in rear axle except that the differential is of Salisbury design. No oil catcher is fitted. The brake drums are 11 in (280 mm) diameter. Both 88 in and 109 in Land-Rover rear axles have the hub assembly retained on the drive shaft with a circlip.

FREE-WHEELING HUBS (Optional Equipment)

Due to the addition of the intermediate front axle shaft oil seal, free-wheeling hubs fitted to vehicles with rationalized axles cannot rely on the axle oil for lubrication. Approved manufacturers will in future supply pre-lubricated hubs but as old stock may be available it is imperative that all new free-wheeling hubs are checked for pre-lubrication.

If lubrication is required any one of the following may be used:

BP	Energrease L2
Castrol	LM Grease
Duckhams	LB 10 Grease
Esso	Multi-purpose Grease H
Mobil	Mobilgrease MP or Mobilgrease Super
Petrofina	Fina Marson HTL2 Grease
Shell	Retinax A
Texaco	Marfak All Purpose Grease

Remove the hub cover plate and smear approximately 3 cm³ of grease inside the hub over the splines.

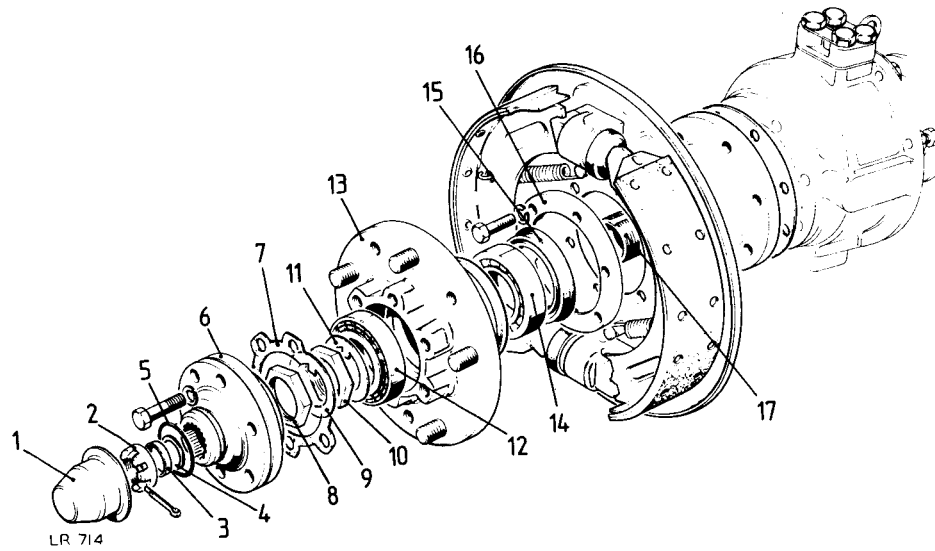

88 in AND 109 in FRONT AXLE HUB

- | | | | |
|---|------------------|----|----------------------|
| 1 | Hub cap | 10 | Inner adjusting nut |
| 2 | Castle nut | 11 | Keyed thrust washer |
| 3 | Distance piece | 12 | Outer roller bearing |
| 4 | Spirolox ring | 13 | Hub |
| 5 | Hub cap 'O' ring | 14 | Inner roller bearing |
| 6 | Driving member | 15 | Dual lipped seal |
| 7 | Joint washer | 16 | Oil catcher |
| 8 | Outer locknut | 17 | Bearing sleeve |
| 9 | Lock washer | | |

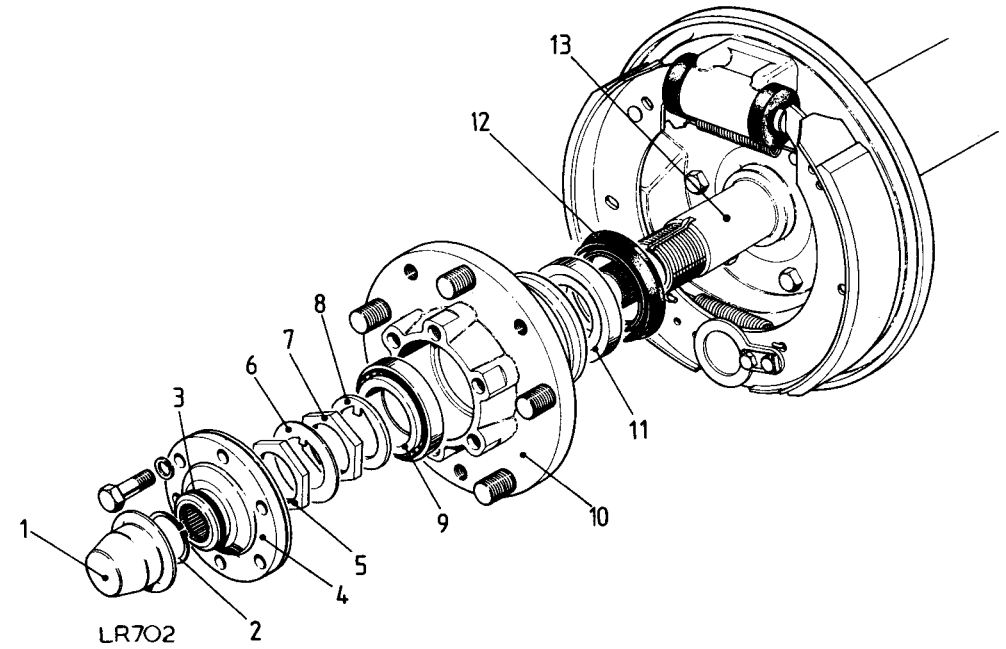

88 in REAR AXLE HUB

- | | | | |
|---|-----------------------|----|----------------------|
| 1 | Hub cap | 8 | Keyed thrust washer |
| 2 | Circlip | 9 | Outer roller bearing |
| 3 | Hub cap 'O' ring seal | 10 | Hub |
| 4 | Driving member | 11 | Inner roller bearing |
| 5 | Outer locknut | 12 | Dual lipped seal |
| 6 | Lock washer | 13 | Bearing sleeve |
| 7 | Inner adjusting nut | | |

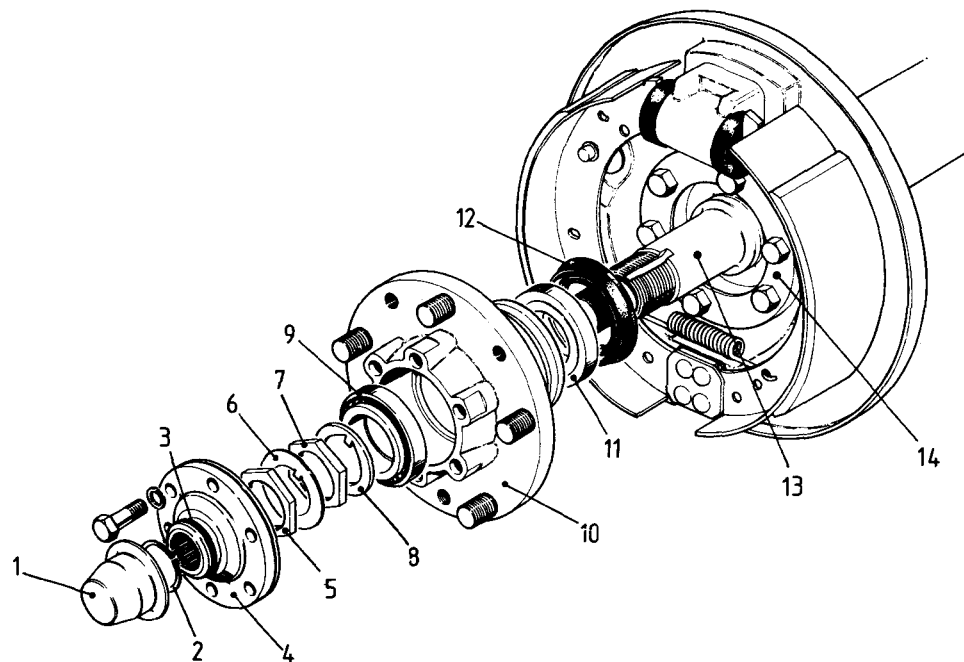

LR703

109 in REAR AXLE HUB

- | | | | |
|---|---------------------|----|---------------------|
| 1 | Hub cap | 8 | Keyed thrust washer |
| 2 | Circlip | 9 | Outer bearing |
| 3 | Hub cap 'O' ring | 10 | Hub |
| 4 | Driving member | 11 | Inner bearing |
| 5 | Outer locknut | 12 | Dual lipped seal |
| 6 | Lock washer | 13 | Bearing sleeve |
| 7 | Inner adjusting nut | 14 | Oil catcher |

LAND-ROVER 88 in AND 109 in FRONT AXLE HUBS

Service tool: 18G 1349

Strip and overhaul procedure

- Slacken the road wheel nuts, jack up the vehicle, lower onto axle stands and remove the road wheels.
- Remove the three brake drum retaining screws and withdraw the brake drum. If necessary, slacken back the brake adjuster to facilitate removal.
- Lever off the hub cap and remove the following: split pin, castle nut, distance piece and Spirolox ring.
- Remove the six bolts and withdraw the driving member and joint washer.
- Bend back the lock washer, remove the outer and inner locknuts and keyed thrust washer.
- Pull off the hub complete with inner and outer bearings and dual lipped seal.
- Clamp the brake jump-hose and disconnect the brake pipe from the wheel cylinder.
- Remove the six bolts and spring washers and withdraw the oil catcher, backplate, and stub axle complete with oil seal and joint washer.

Overhauling hub

- Remove the oil seal and if new bearings are to be fitted, press or drift out the old bearing cups.
- Examine the road wheel studs and renew any that are worn or damaged.
- Press in new bearing cups up to the shoulder.
- Ensure that there are no imperfections in the hub oil seal housing that could cause damage to the seal.
- Pack the inner bearing with Shell Retinax A grease or equivalent, and fit to the hub.
- While taking care not to touch the seal lips, liberally smear—not pack—the cavity between the seal lips with Shell Retinax A or equivalent.
- To avoid possible damage to the seal and to ensure the correct depth into the hub, press-in the seal, lip side leading, using special tool 18G 1349.

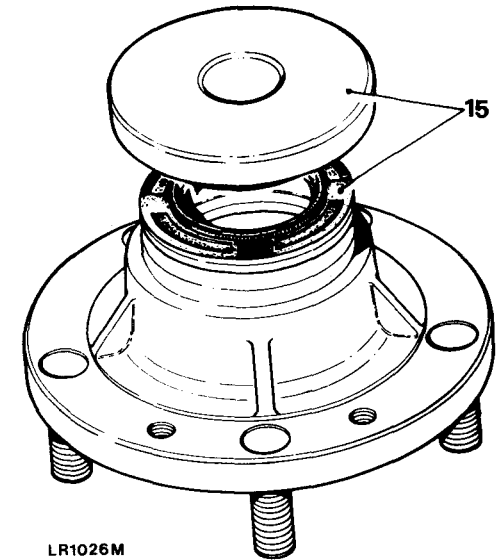

LR1026M

continued

- 16 With the cavity side leading, press in the seal so that it is recessed 4,8 to 5,3 mm (0.190 to 0.210 in) from the rear face of the hub.

Reassembling hub to axle

- 17 Remove the old oil seal from the bearing sleeve. Grease the outside diameter of the new seal and with the lip side leading press fully home into the bearing sleeve.
- 18 Using a new joint washer, assemble the bearing sleeve to the swivel housing, ensuring that the milled slot is at the bottom.
- 19 Fit the backplate so that the drain hole is in line with the milled slot.
- 20 Using Hylomar SQ 32M, fit and seal the oil catcher to the backplate.
- 21 Mount a dial test indicator so that the stylus rests on the adjusting nut. Slacken the nut back to obtain an end-float of 0,050 to 0,101 mm (0.002 to 0.004 in.).
- 22 Before fitting the hub ensure that the journal on which the dual lipped seal runs is clean and free from damage that could destroy the seal.
- 23 Fit the hub to the bearing sleeve. Pack the outer bearing with grease and fit to the hub.
- 24 Fit the keyed thrust washer and adjusting inner locknut.
- 25 Tighten the adjusting nut, by hand, whilst rotating the hub until all the end-play is taken up.
- 26 Mount a dial test indicator so that the stylus rests on the adjusting nut. Slacken back the nut until an end-float of 0,050 to 0,101 mm (0.002 to 0.004 in) is achieved.
- 27 Fit the keyed lock washer and tighten against the inner nut. Re-check the end-float and lock the nuts.
- 28 Using a new joint washer, fit the hub driving member and retain with the six bolts and spring washers. Tighten to 4,2 to 5,2 kgf m (30 to 38 lbf ft).
- 29 Fit the Spirolox ring, distance piece and castle nut. Using the special hub nut socket RO 1010, tighten to 1,4 to 2,0 kgf m (10 to 14 lbf ft) and secure the nut with a split pin.
- 30 If necessary, fit a new 'O' ring and fit the hub cap.
- 31 Fit the brake drum, and secure with new screws if necessary.

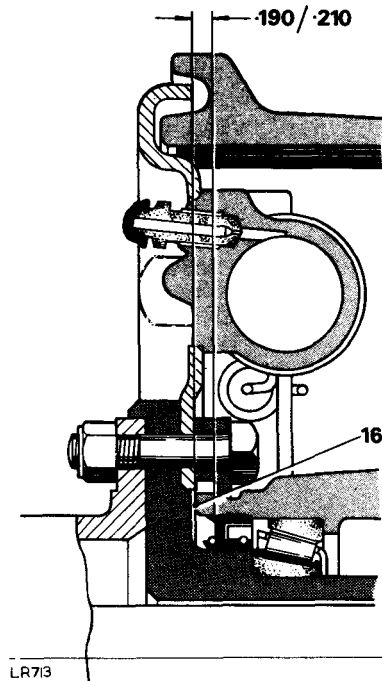

LR7/3

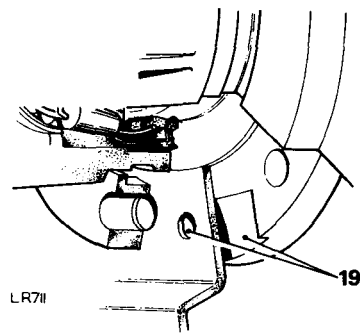

LR7/II

- 32 Adjust the brakes, release the jump hose clamp and bleed the hydraulic system.
- 33 Fit the road wheels, using new nuts if necessary.
- 34 Lower the vehicle, remove the axle stands and finally tighten the wheel nuts to 10.3 to 11.7 kgf m (75 to 85 lbf ft).

LAND-ROVER 109 in AXLE HUB (With Oil Catcher)

LAND-ROVER 88 in AXLE HUB (Without Oil Catcher) omit instructions 7 and 17

Service tool: 18G 1349

Strip and overhaul procedure

- Slacken the road wheel retaining nuts, jack up the vehicle, lower onto axle stands and remove the road wheels.
- Remove the three brake drum retaining screws and withdraw the brake drum. If necessary, slacken the brake adjuster to facilitate removal.
- Lever off the hub cap and remove the axle shaft circlip.
- Remove the six bolts and withdraw the hub driving member and joint washer.
- Unlock the tab washer, remove the outer and inner locknuts and keyed thrust washer.
- Withdraw the hub complete with inner and outer taper roller bearings and dual lipped seal.
- If required, remove the oil catcher and bearing sleeve by removing the six brake backplate retaining nuts and bolts.

Overhauling hub

- Remove the dual lipped seal and inner bearing from the hub.
- If new bearings are to be fitted drift or press out the old bearing cups.
- Examine the road wheel studs and renew any worn or damaged ones.
- Press in new bearing cups up to the shoulder.
- Examine the oil seal housing in the hub and remove any burrs that could damage the seal.
- Pack the inner bearing with Shell Retinax A grease or equivalent and fit to the hub.
- While taking care not to touch the seal lips, liberally smear—not pack—the cavity between the seal lips with Shell Retinax A or equivalent.
- To avoid possible damage to the seal and to ensure the correct depth into the hub, press-in the seal, lip side leading, using special tool 18G 1349.

continued

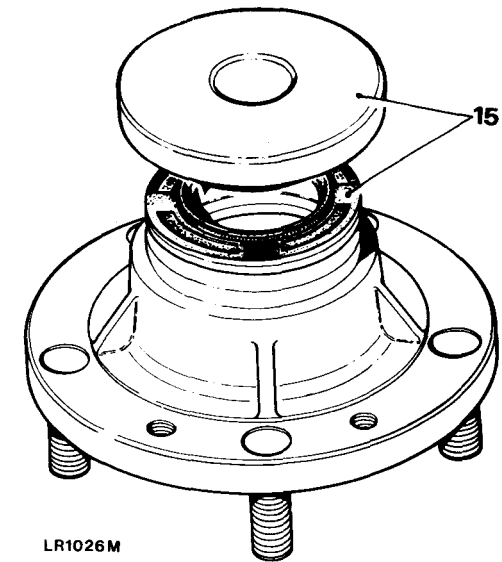

LR1026 M

- 16 With the cavity side leading, press in the seal so that it is recessed 4,8 to 5,3 mm (0.190 to 0.210 in) from the rear face of the hub.

Reassembling hub to axle

- 17 If removed, assemble the bearing sleeve, backplate and oil catcher to the axle having first smeared Hylomar SQ32M on the face of the oil catcher to seal it to the backplate. Ensure that the milled slot in the bearing sleeve and the drain hole in the backplate line up at the bottom. Secure the assembly to the axle with the six bolts and nuts and tighten to 6,0 to 8,0 kgf m (48 to 59 lbf ft).
- 18 Before fitting the hub, ensure that the journal on which the dual lipped seal runs is clean and free from imperfections that could damage the seal.
- 19 Fit the hub to the bearing sleeve, pack the outer bearing with grease and fit to the hub.
- 20 Fit the keyed thrust washer and adjusting inner nut. Tighten the nut, by hand, whilst rotating the hub until all the end-play is taken up.
- 21 Mount a dial test indicator so that the stylus rest on the adjusting nut. Slacken the nut back to obtain an end-float of 0,050 to 0,101 mm (0.002 to 0.004 in.).
- 22 Fit the tab washer and outer locknut. Tighten the locknut, re-check the end-float and lock the nuts.
- 23 Using a new joint washer, fit the hub driving member and tighten the retaining bolts and spring washers to 4,2 to 5,2 kgf m (30 to 38 lbf ft)
- 24 Fit the circlip to the axle shaft, ensuring that it locates correctly in the groove.
- 25 Fit the hub cap, if necessary using a new 'O' ring seal.
- 26 Fit the brake drum and secure, if necessary with new screws.
- 27 Adjust the brake shoes to the drum.
- 28 Fit the road wheels, using new nuts if necessary.
- 29 Remove the vehicle from the axle stands and finally tighten the wheel nuts to 10,3 to 11,7 kgf m (75 to 85 lbf ft).

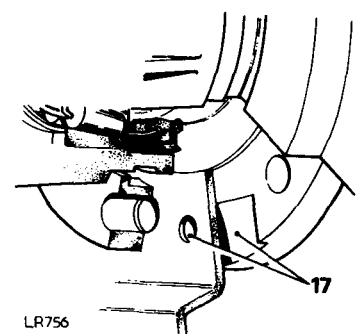
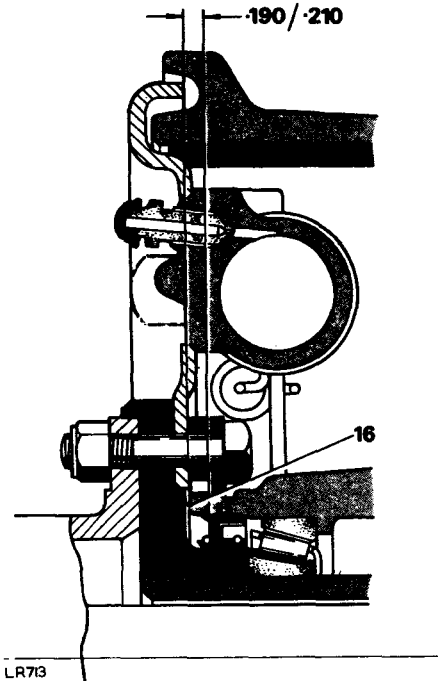

REAR HUB

Remove and refit

64.15.01

Removing

- 1 Jack up the vehicle and support securely,
- 2 Remove the road wheel.
- 3 Remove the bolts and spring washers securing the drive flange to the hub.
- 4 Withdraw the half shaft complete with drive flange and gasket.
- 5 Slacken off brake shoe adjustment.
- 6 Remove the brake drum.
- 7 Straighten the lock tabs securing the hub nuts.
- 8 Remove the hub lock nut, lock washer, adjusting nut and tongued washer.
- 9 Withdraw the hub complete with inner and outer bearings and oil seal.

Refitting

- 10 Fill the hub to half capacity with fresh grease.
- 11 Install the hub on the stub axle complete with inner and outer bearings and oil seal.
- 12 Fit the tongued washer and adjusting nut.
- 13 Spin the hub to settle the bearings and tighten the adjusting nut sufficient to provide hub end-float of 0,05 to 0,10 mm (0.002 to 0.004 in.). This can be checked using a dial gauge.
- 14 Fit the lock washer and lock nut. Tighten the lock nut. Bend the lock washer to secure both the locknut and adjusting nut. Recheck end-float.
- 15 Reverse instructions 1 to 6.

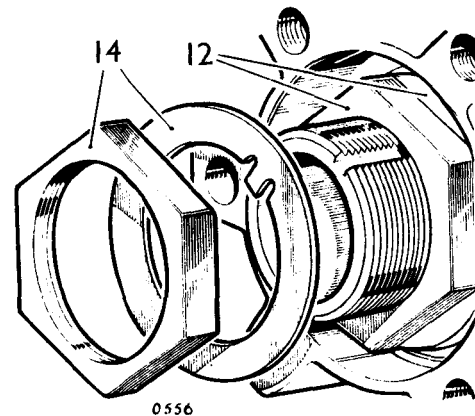
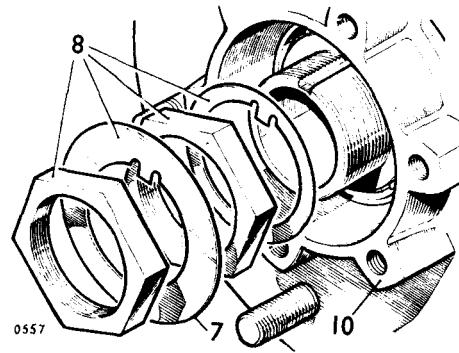
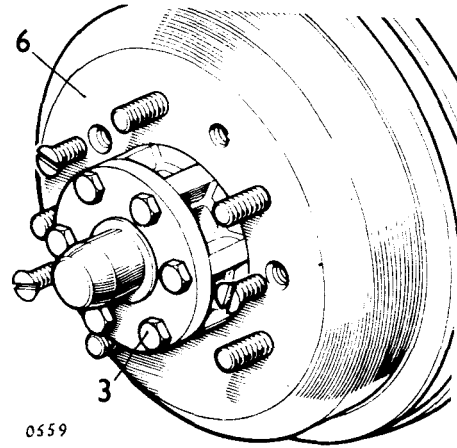
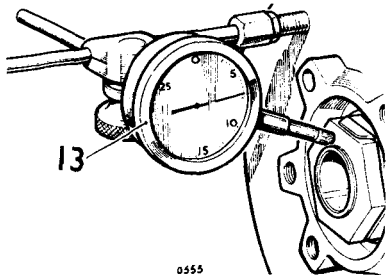

REAR DRIVE FLANGE

Remove and refit Left hand 64.15.04
Right hand 64.15.05

Removing

- 1 Jack up the vehicle and support securely.
- 2 Remove the road wheel.
- 3 Twist and slide off the hub cap.
- 4 a 88 Models. Remove the split pin, slotted nut, and washer securing the half shaft to the drive flange. Remove the sealing washer. Note that the plastic face of the sealing washer is fitted adjacent to the driving flange.
- b 109 Models. Remove the circlip securing the half shaft to the driving flange.
- 5 Remove the bolts and spring washers securing the driving flange to the hub.
- 6 Withdraw the driving flange and gasket. Remove the 'O' ring from the driving flange if necessary - 109 models only.

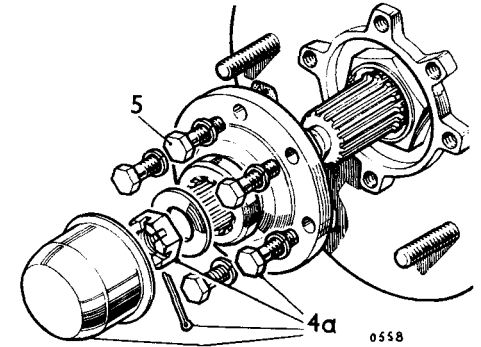

Refitting

- 7 Reverse instructions 1 to 6.

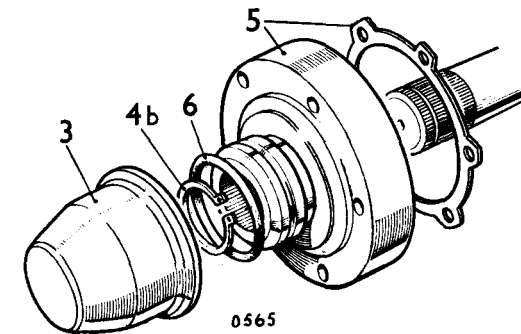

REAR HUB BEARING END-FLOAT

Check and adjust 64.15.13

Checking

- 1 Carry out instructions 1 to 6, Operation 64.15.01.
- 2 Using a dial gauge check hub end-float. Hub end-float should be within 0,05 to 0,10 mm (0.002 to 0.004 in.).

Adjusting

- 3 Straighten the lock washer tabs securing the hub locknut and adjusting nut.
- 4 Remove the lock nut and lock washer.
- 5 Set the adjusting nut as required to obtain the required end-float given in 2 above.
- 6 Fit the lockwasher and locknut.
- 7 Bend the lockwasher to secure both the adjusting nut and locknut. Recheck end-float.
- 8 Reverse instructions 1 to 6. Operation 64.15.01.

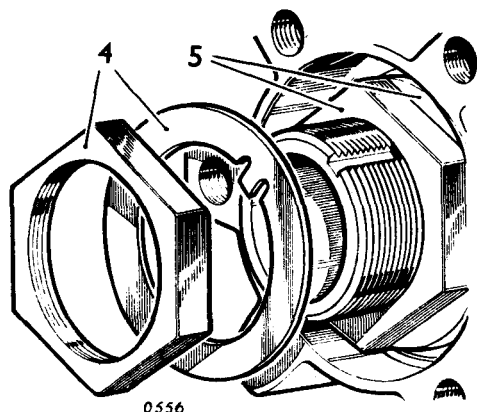
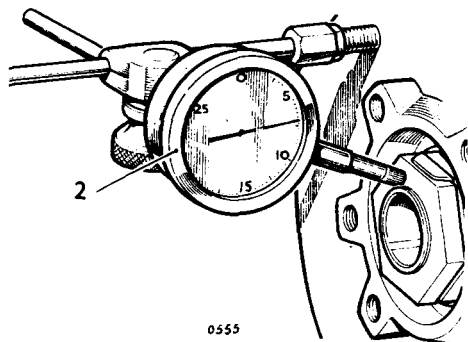

REAR HUB BEARINGS

Remove and refit 64.15.14

Removing

- 1 Remove the rear hub. 64.15.01.
- 2 Withdraw the outer bearing.
- 3 Remove the inner bearing and oil seal. Discard the oil seal.
- 4 Remove the inner and outer bearing tracks.
- 5 Thoroughly clean the hub and bearings.

Refitting

- 6 Fit the inner and outer bearing tracks.
- 7 Fill the hub to half capacity with fresh grease.
- 8 Fit the inner bearing and a new oil seal. Ensure that the seal lip faces toward the bearing and that the seal lip is lubricated.
- 9 Fit the outer bearing.
- 10 Fit the hub to the stub axle.
- 11 Fit the tongued washer and adjusting nut.
- 12 Adjust hub bearing end-float to within 0,05 to 0,10 mm (0.002 to 0.004 in.).
- 13 Fit the lock washer and lock nut. Bend the lock washer to secure both the lock nut and the adjusting nut.
- 14 Reverse instructions 1 to 6. 64.15.01.

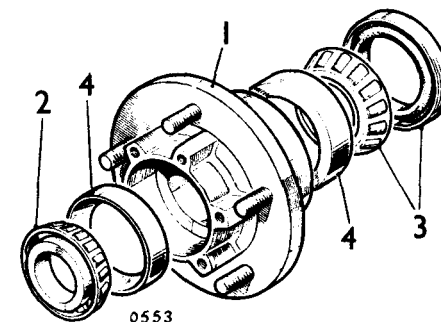

REAR HUB OIL SEAL

Remove and refit 64.15.15

Removing

- 1 Remove the rear hub, instructions 1 to 9. Operation 64.15.01.
- 2 Remove the oil seal and discard.

Refitting

- 3 Fit a new oil seal to the hub, seal lip towards the hub inner bearing. Lubricate the seal lip.
- 4 Reverse instructions 1 to 9. Operation 64.15.01.

REAR HUB STUB AXLE

Remove and refit Left hand 64.15.20
Overhaul Right hand 64.15.21

Removing

- 1 Remove the rear hub, instructions 1 to 9. Operation 64.15.01.
- 2 Disconnect the brake pipe at the wheel cylinder. Plug the wheel cylinder and brake pipe to prevent ingress of foreign matter.
- 3 Remove the six bolts and nuts securing the brake backplate and stub axle to the rear axle flange.
- 4 Detach the brake backplate from the stub axle.
- 5 Remove the stub axle and gasket. Discard the gasket.

Overhaul

- 6 Examine the stub axle for wear and damage. Check the peripheral surface of the distance collar. This area of the collar forms the running surface of the hub oil seal lip. Wear or ridging will result in rapid oil seal deterioration and ineffectiveness. Renew the collar if necessary. The collar is a press fit on the stub axle. Remove the collar by drilling and splitting, taking care to avoid marking or damaging the stub axle. Press on a new collar.

Refitting

- 7 Reverse instructions 1 to 5.
- 8 Bleed the brakes.

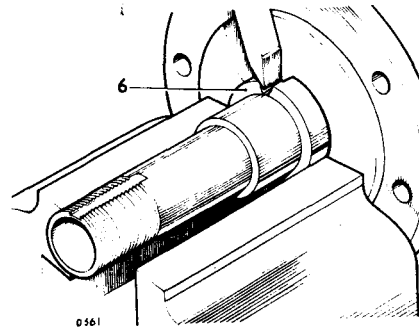
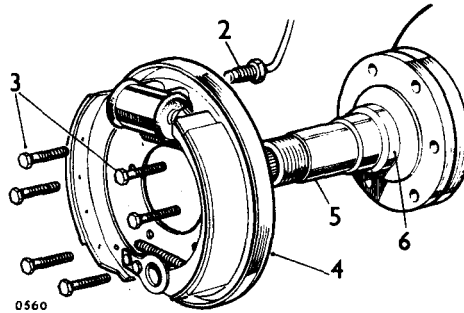

REAR ROAD SPRING

Remove and refit 64.20.01

Removing

- 1 Rear springs, driver's side and passenger's side must not be interchanged. Springs can be identified by the increased camber of the spring fitted to the driver's side and by the part number stamped on the underside of the third leaf. The exception to the above is 109 1 ton models. On this vehicle both rear springs are identical.
- 2 Jack up the vehicle and support the chassis securely.
- 3 Remove the road wheel.
- 4 With the jack positioned under the rear axle relieve the road springs of load.
- 5 Remove the road spring 'U' bolts.
 - a 88 models. Slide the spring plate clear of the spring.
 - b 109 models. Remove the spring plate.
- 6 Remove the shackle bolt nuts.
- 7 Slacken the rear, upper shackle bolt. The rear shackle bolts are screwed to the inner shackle links. 109 1 ton models. Slacken the shackle link centre bolt and nut. Note that a spacer and shims are fitted between the shackle links.
- 8 Remove the spring shackle bolts.
- 9 Remove the road spring.

continued

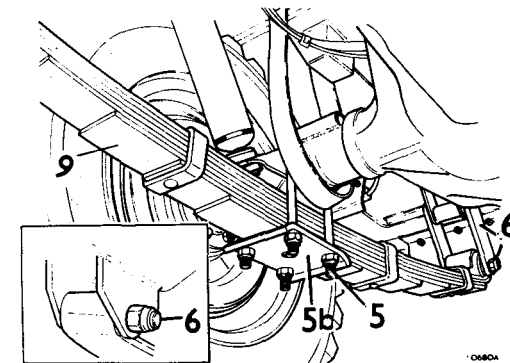
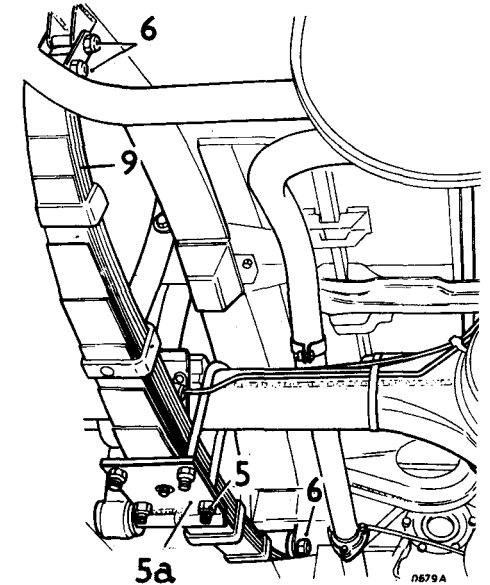
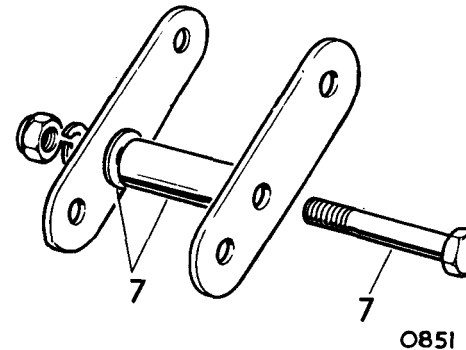

Refitting

- 10 Reverse instructions 4 to 9 but do not tighten the shackle bolts or shackle bolt nuts. Ensure that the axle is properly located in the spring centre bolt before fitting and tightening the 'U' bolts to 8,0 kgf m (58 lbf ft).

Spring setting procedure

- 11 The shackle bolts which clamp the centre member of the road spring and hangar bracket bushes must not be tightened until the spring is positioned in the mid-point of its deflection range. This ensures that excessive rotation/shear forces are not imparted to the bush centres. Failure to observe this instruction can adversely affect bush life, especially in off-road conditions which produces large spring deflections.
- 12 Deflect the spring towards the chassis to the required dimension by using a length of chain passed over the chassis and under a lifting trolley jack. Alternatively lower the vehicle on its wheels and load the vehicle.
Dimension 'A', 88 in Models, 142,0 to 146,0 mm.
Dimension 'B', 109 in Models, 158,0 to 162,0 mm.
- 13 Tighten the spring shackle bolts and nuts to 8,3 to 9,7 kgf m (60 to 70 lbf ft).

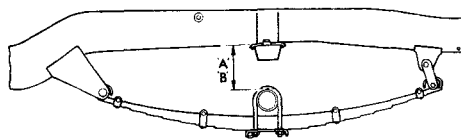

7PC 159A

- 14 On 109 in 1 ton models tighten the shackle link centre bolt and nut.

REAR ROAD SPRING**Overhaul**

64.20.04

- 1 Only the main leaf and second leaf are available as spares items. For spring data refer to Section 04.

When refitting the spring centre bolt it is suggested that the plain nut is substituted by a nut of the self-locking type to prevent the centre bolt slackening in service.

Spring eye bushes

- 2 Remove and refit using a press. Spring eye bushes must be located centrally in the spring.

REAR SPRING HANGAR BRACKET BUSH**Remove and refit**

64.20.21

Removing

- 1 Jack up the vehicle and support the chassis securely. Retain the jack in position to support the rear axle.
- 2 Remove the road wheel.
- 3 Remove the spring shackle lock nuts.
- 4 Slacken the front shackle bolt.
- 5 **109 1 ton models only.** Slacken the rear shackle centre bolt and nut.
- 6 Slacken the lower rear shackle bolt, remove the upper shackle bolt and swing the shackle links clear of the chassis.
- 7 Using a drift of suitable dimensions, or a length of solid drawn steel tubing and a long bolt and washers extract the bush from the hangar bracket. Where difficulty is experienced and the bush inner member and rubber separate from the bush outer shell the outer shell may be removed by splitting it with a hacksaw. Care must be taken to avoid marking the hangar bracket.

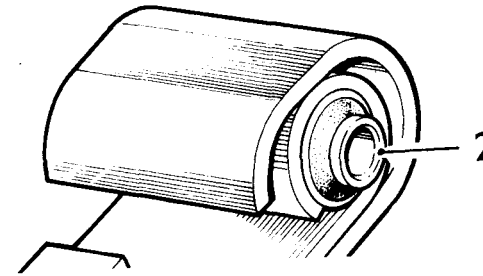

O531

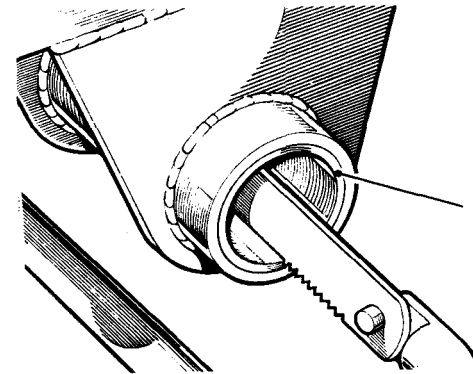

O534

REAR SHOCK ABSORBER**Remove and refit**

64.30.05

Removing

- 1 Jack up the vehicle and support securely.
- 2 Remove the road wheel.
- 3 a **88 models.** Remove the split pin and washer securing the lower end of the shock absorber to the spring plate.
- b **109 models.** Remove the nut securing the lower end of the shock absorber to the axle bracket. Release the shock absorber from the axle bracket and withdraw the two rubber bushes and the four bush seating washers.

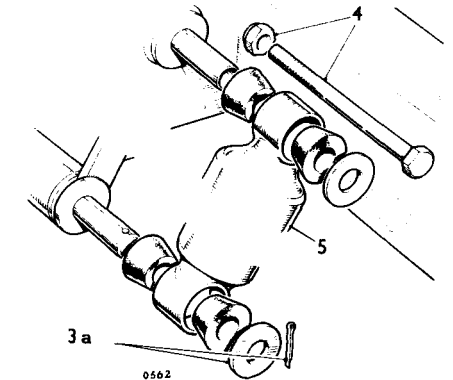

3 a

0562

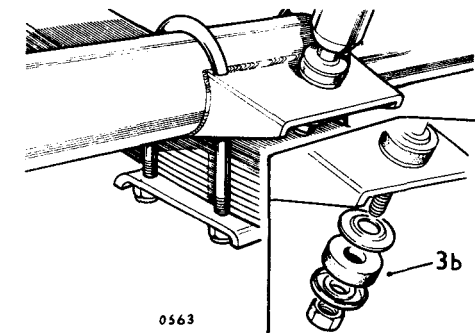

0563

Refitting

- 8 Clean the hangar bracket bore.
- 9 Using a long bolt and washer pull the new bush into position in the hangar bracket. Ensure it is located centrally in the hangar bracket.
- 10 Fit the rear shackle links and the rear upper shackle bolt but do not tighten at this stage.
- 11 Carry out spring setting procedure, instructions 11 to 13. Operation 64.20.01.

- 4 Remove the bolt, washer and nut securing the upper end of the shock absorber to the chassis.

continued

- 5 Withdraw the shock absorber complete with bushes.

Checking shock absorber operation

- 6 Hold the shock absorber vertically in a vice.
7 The shock absorber employs differential damping having greater resistance on the extension stroke. Check operation by extending and compressing the shock absorber.

Resistance should be uniform throughout the length of each stroke. If resistance is erratic or weak, renew the shock absorber. When checking resistance a new shock absorber may be used for comparison.

Refitting

- 8 Reverse instructions 1 to 5.

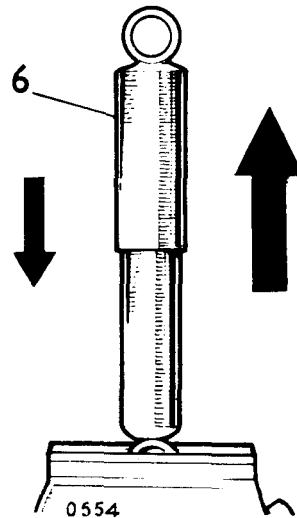

CHECK STRAP

Remove and refit

64.30.17

Removing

- 1 Remove the bolts, nuts and washers securing the check strap to the chassis.
- 2 Remove the check strap.

Refitting

- 3 Reverse instructions 1 and 2.

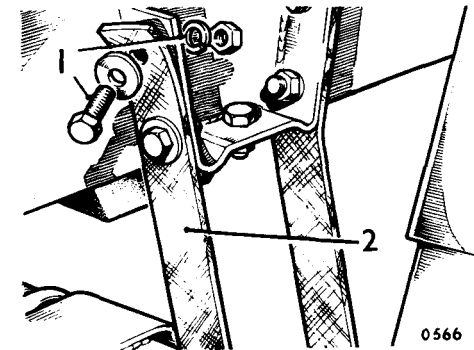

BUMP STOP

Remove and refit

64.30.10

Removing

- 1 Remove the two bolts, nuts and spring washers securing the bump stop to the chassis.
- 2 Remove the bump stop

Refitting

- 3 Reverse instructions 1 and 2.

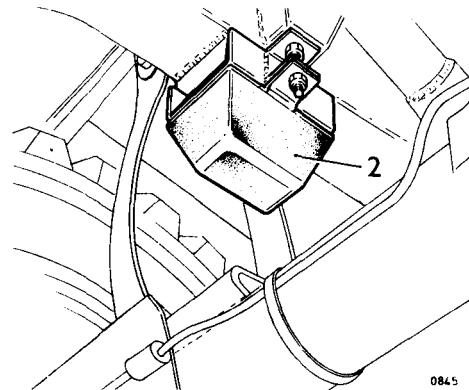

BRAKE WARNING LIGHT

General information 70.00.00

Warning light function

- 1 An amber warning light marked 'BRAKE' is provided on the instrument panel on models for certain territories only.
- 2 The following brief description of the warning light function is intended as a guide to aid in brake system fault diagnosis.
- 3 The warning light is in series circuit with one or more of the following warning indicator switches to provide a visual indication of brake lining wear, hydraulic fluid leakage or servo vacuum loss, depending on the particular equipment provided on the vehicle:-
 - a A servo mounted vacuum switch which indicates lack of vacuum assistance at the brake servo.
 - b A pedal-box mounted pedal travel switch to give an indication of excess pedal travel caused by brake shoe wear or minor hydraulic leakage.
 - c A chassis mounted pressure differential switch which indicates fluid leakage in the front or rear brake hydraulic systems.
 - d A dash mounted test switch which is push button operated. Failure of the bulb to illuminate on being tested could indicate a faulty bulb or earth connection.

Fault diagnosis—Brake warning light 'ON'

General

- 4 The brake warning light circuit is energised with the ignition switched 'ON' only.
- 5 The warning indicator switches are normally on open circuit and short the circuit to earth, to illuminate the brake warning light, when the switches are closed (refer to the accompanying schematic circuit diagram).

Procedure—Ignition switch 'ON'—test button fully out from dash.

- 6 Servo vacuum switch—Petrol models (for Diesel models, see item 7).
 - a Ensure vacuum is available at the switch by checking the hose connections for soundness, then running the engine for a short period during which engine overrun conditions are obtained, that is, throttle opened then allowed to quickly close.
 - b With vacuum available, if the brake warning light remains 'ON', disconnect the electrical leads at the vacuum switch and connect together the leads, using a slave Lucar male connector blade.
 - c If the light is extinguished, the vacuum switch is faulty and must be replaced. If the warning light remains 'ON', leave the leads connected together and proceed to the next switch in the circuit.

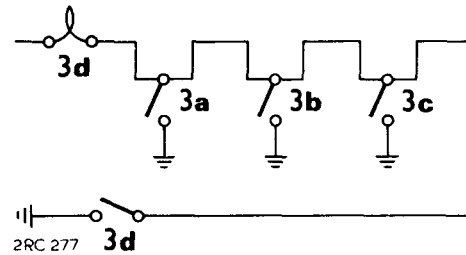

7 Servo vacuum switch—Diesel models.

General

Before faulting the servo vacuum switch on diesel models, check the following items a to c for correct operation:-

- a Remove the hose and unscrew the non-return valve from the underside of the inlet manifold. Check for the valve sticking closed by blowing with the mouth into the hose connector end of the valve (do not use high pressure air); the air should pass through freely. Renew the valve to rectify.

- b Remove the air inlet hose from the inlet manifold and check that the manifold butterfly valve is fully closed with the accelerator linkage in the idle position. Adjustment is made at the pinch bolt which secures the butterfly valve linkage to the accelerator cross-shaft.

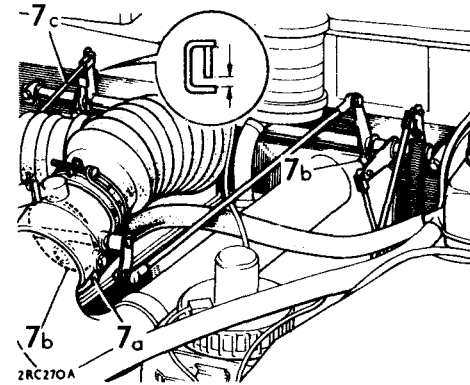

- c If adjustment is required, observe that the space between the front and rear arms of the forked shaft, which actuates the distributor pump linkage, provides a 'lost motion' period during which the accelerator cross-shaft rotates but the pump linkage does not. Set the pump linkage at the cross-shaft pinch bolt such that the butterfly valve will open in advance of the pump linkage.
- d When the foregoing items are satisfactory, carry out the switch checking sequence described in item 6. If a replacement switch does not effect a cure for the warning light 'ON' condition, check the actual depression present in the inlet manifold at overrun conditions, using a suitable gauge interposed between the inlet manifold and the vacuum reservoir tee-piece. Opening and closing the throttle sharply several

- times with the engine running should enable a depression of at least 15 in Hg. to be registered on the gauge, this being sufficient to actuate the servo vacuum switch.
- 8 Brake pressure differential switch.
 - a Disconnect the switch leads and interconnect them to remake the circuit.
 - b If the warning light remains 'ON', proceed to check the next switch in the circuit; if the light is extinguished, check for hydraulic system leakage which would cause the differential switch plunger to displace to one end.

NOTE: On dual braking systems, the hydraulic fluid reservoir is divided into two compartments. On 88 models, the front compartment supplies the rear brakes and the rear compartment the front brakes; on 109 models, however, the reverse applies and the front compartment supplies the front brakes, the rear compartment supplies the rear brakes. A difference in fluid levels may indicate which system is leaking. Fluid leaks must be rectified before centralising the switch.

- c To centralise the differential switch plunger, bleed a brake line in the pressurised system (front or rear as applicable) use very slow pedal travel and observe the brake warning light. Immediately the warning light is extinguished, keep a light pressure on the pedal and close the bleed nipple.
- 9 Pedal travel switch
 - a Check that the switch is set (by means of the locknut on the mounting bracket) to operate within 111 to 117 mm (4.37 to 4.60 in.) pedal travel movement towards the floor.
 - b Disconnect the switch leads and interconnect them to remake the circuit.
 - c If the warning light remains on, renew the switch.

BRAKE DRUMS

Remove and refit	
Front drums	70.10.02
Rear drums	70.10.03

Removing

- 1 Jack up the vehicle and support securely.
- 2 Remove the road wheel.
- 3 Slacken off the brake adjuster/s at the brake anchor plate.
- 4 Remove the brake drum fixings.
- 5 Withdraw the brake drum.

WARNING: Do not blow out the dust in a brake drum; it is dangerous if inhaled.

Refitting

- 6 Reverse instructions 1 to 5.

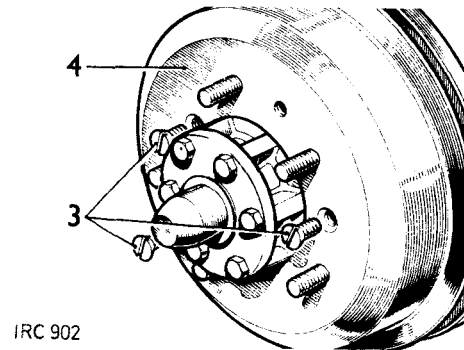

IRC 902

DATA**Brake drums****Diameter:**

88 in models, front and rear	254 mm (10 in)
109 in models, front and rear	279,4 mm (11.0 in)

Reclamation limit:

	<i>Drum diameter</i>	<i>Drum maximum oversize</i>
88 in pre-rationalized front and rear axle	254 mm (10.0 in)	255,52 mm (10.06 in)
88 in current production front axle	279,4 mm (11.0 in)	280,92 mm (11.06 in)
88 in current production rear axle	254 mm (10.0 in)	255,52 mm (10.06 in)
109 in 2¼ litre and 2.6 litre front and rear axle	279,4 mm (11.0 in)	280,92 mm (11.06 in)

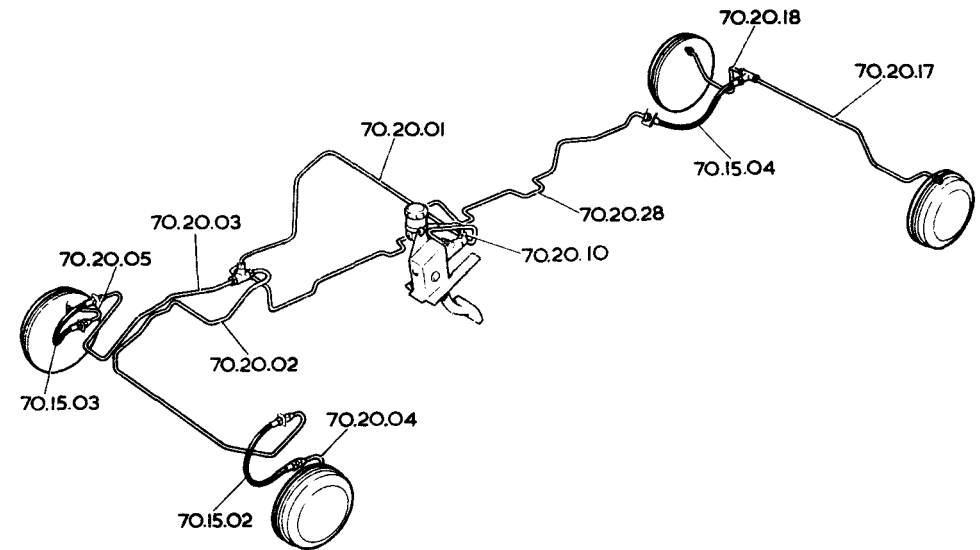

IRC 695

BRAKE HOSES AND PIPES**Single system, non-servo models****HOSES**

Remove and refit	
Front left hand	70.15.02
Front right hand	70.15.03
Intermediate	70.15.04

Feed to master cylinder	70.20.10
Feed to rear left hand cylinder	70.20.17
Feed to rear right hand cylinder	70.20.18
Feed to intermediate hose	70.20.28

PIPES

Remove and refit	
Feed to front multi-way connector	70.20.01
Feed to front left hand hose connector	70.20.02
Feed to front right hand hose connector	70.20.03
Feed to front left hand cylinder	70.20.04
Feed to front right hand cylinder	70.20.05

NOTE: The operation numbers are included on the brake system illustration to facilitate identification of the individual pipes.

Removing

- 1 Disconnect the hose or pipe at both connections.
- 2 Release the clipping.
- 3 Withdraw the hose or pipe.

Refitting

- 4 Reverse instructions 1 to 3.
- 5 Bleed the brakes 70.25.02.

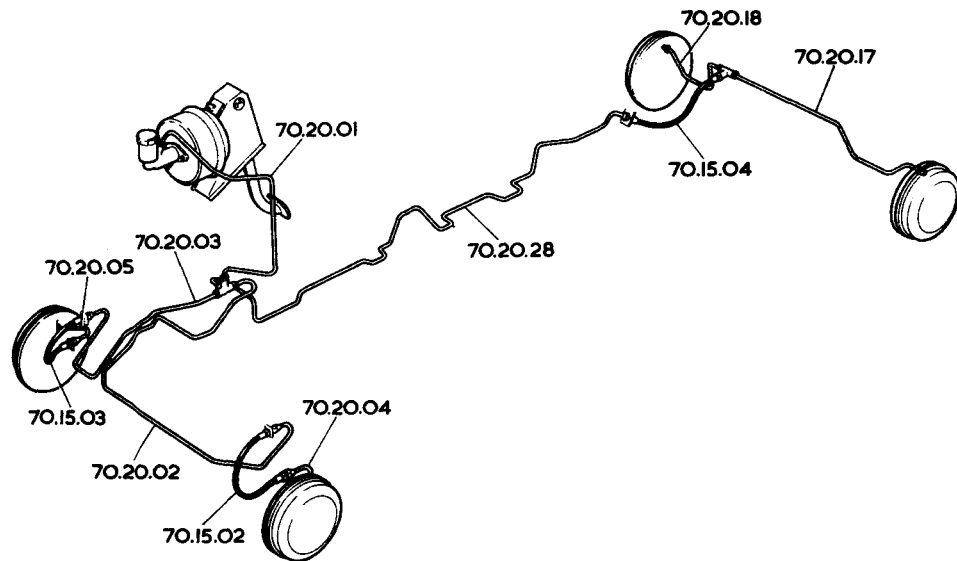

IRC 696

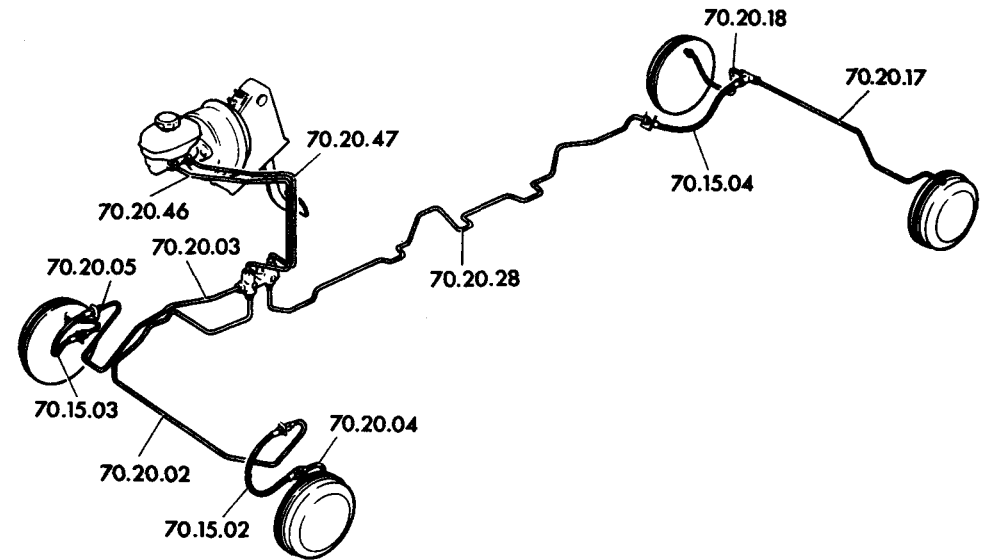

IRC897

BRAKE HOSES AND PIPES

Single system models with servo

HOSES

Remove and refit	
Front left hand	70.15.02
Front right hand	70.15.03
Intermediate	70.15.04

PIPES

Remove and refit	
Feed to front multi-way connector	70.20.01
Feed to front left hand hose connector	70.20.02
Feed to front right hand hose connector	70.20.03
Feed to front left hand cylinder	70.20.04
Feed to front right hand cylinder	70.20.05

Feed to rear left hand cylinder	
Feed to rear right hand cylinder	70.20.17
Feed to intermediate hose	70.20.28

NOTE: The operation numbers are included on the brake system illustration to facilitate identification of the individual pipes.

Removing

- 1 Disconnect the hose or pipe at both connections.
- 2 Release the clipping.
- 3 Withdraw the hose or pipe.

Refitting

- 4 Reverse instructions 1 to 3.
- 5 Bleed the brakes 70.25.02.

BRAKE HOSES AND PIPES

Dual system models

HOSES

Remove and refit	
Front left hand	70.15.02
Front right hand	70.15.03
Intermediate	70.15.04

PIPES

Remove and refit	
Feed to front left hand hose connector	70.20.02
Feed to front right hand hose connector	70.20.03
Feed to front left hand cylinder	70.20.04
Feed to front right hand cylinder	70.20.05

Feed to rear left hand cylinder	70.20.17
Feed to rear right hand cylinder	70.20.18
Feed to intermediate hose	70.20.28
Feed to brake failure switch, front system	70.20.46
Feed to brake failure switch, rear system	70.20.47

NOTE: The operation numbers are included on the brake system illustration to facilitate identification of the individual pipes.

Removing

- 1 Disconnect the hose or pipe at both connections.
- 2 Release the clipping.
- 3 Withdraw the hose or pipe.

Refitting

- 4 Reverse instructions 1 to 3.
- 5 Bleed the brakes 70.25.02.

FOUR-WAY CONNECTOR, Single system

Remove and refit 70.15.35

Removing

- 1 Disconnect and blank off the four fluid pipes.
- 2 Remove the four-way connector and bracket, located in the engine compartment on top of the chassis R.H. side member.

Refitting

- 3 Fit the four-way connector with the connection for the rear brakes pipe facing outboard.
- 4 Bleed the brakes. 70.25.02.

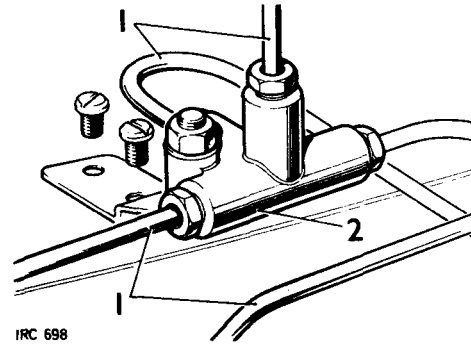

BRAKE FAILURE SWITCH, Dual systems

Overhaul 70.15.41

Dismantling

- 1 Remove the switch assembly. 70.15.36.
- 2 Remove the switch unit from the housing.
- 3 Withdraw the plunger ball.
- 4 Remove the end plug and sealing washer.
- 5 Remove the pipe connector union and sealing washer.
- 6 Push out the two-part shuttle valve, using a soft drift.
- 7 Remove and discard the shuttle valve oil seals.

Inspecting

- 8 Clean the shuttle valve, end plug, pipe union and five-way connector, using new brake fluid or ethyl alcohol.
- 9 Examine the shuttle valve and its bore in the five-way connector, they must be in perfect condition with no signs of scratches or corrosion, otherwise fit a new switch complete.
- 10 To test the electrical switch, reconnect the leads and actuate the switch plunger by pressing it against an earthing point on the vehicle.

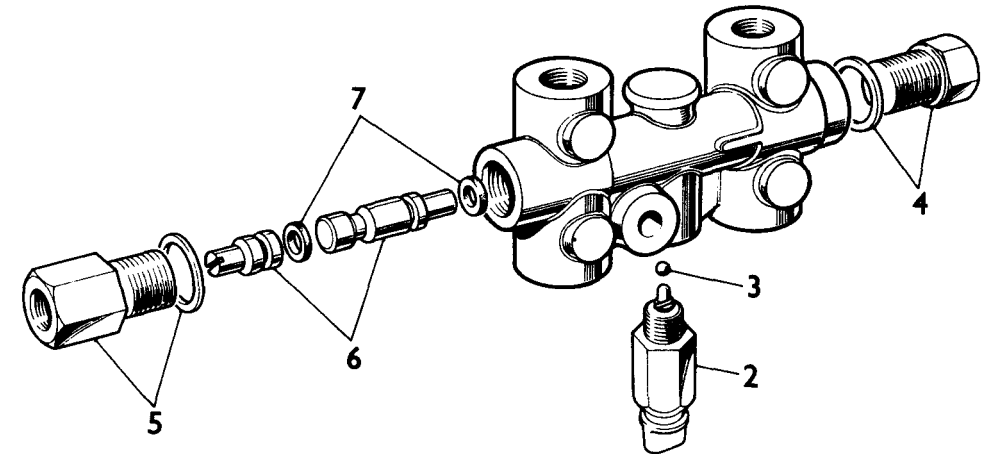

BRAKE FAILURE SWITCH, Dual systems

Remove and refit 70.15.36

Removing

- 1 Disconnect the electrical leads from the brake failure switch, located in the engine compartment at the chassis R.H. side member.
- 2 Disconnect and blank off the five fluid pipes.
- 3 Remove the brake failure switch.

Refitting

- 4 Secure the brake failure switch in position, with the electrical leads socket uppermost.
- 5 Reverse instructions 1 and 2.
- 6 Bleed the brakes. 70.25.02.

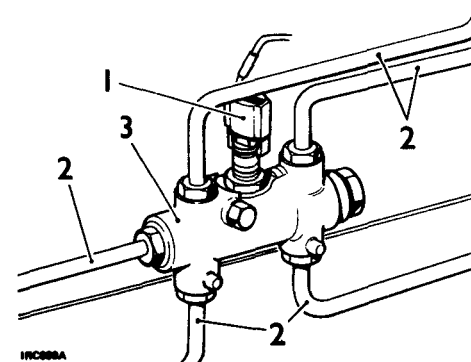

Assembling

- 11 If the plunger spring is dislodged, refit with the small coil of the spring toward the switch unit threads.
- 12 Position the plunger spring 4,06 mm (0.160 in.) approximately from the plunger end.

continued

- 13 Fit new shuttle valve seals.
- 14 Coat the seals with Girling brake lubricant or clean brake fluid.
- 15 Fit the longer shuttle valve, slotted end last, to the end plug end of the housing bore.
- 16 Position the shuttle valve to align the groove for the plunger ball with the drilling for the ball.
- 17 Fit the ball and switch unit. Torque loading 17,28 kgf. cm (15 lbf. in.).
- 18 Fit the shorter shuttle valve, slotted end last, to the pipe connector end of the housing bore.
- 19 Reverse instructions 4 and 5, using new sealing washers. Torque 2,2 kgf. m (16 lbf. ft.).
- 20 Fit the switch assembly. 70.15.36.

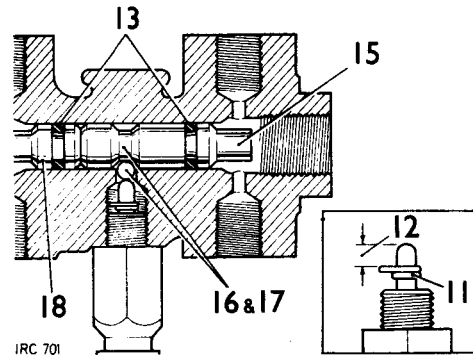

BRAKES

Bleed 70.25.02

General

- 1 Observe strict cleanliness precautions to prevent foreign matter from entering the hydraulic system.
- 2 Use only new supplies of the recommended brake hydraulic fluid (see 09—Lubricants and Fluids).
- 3 Keep the fluid reservoir 'topped up' during bleeding.
- 4 Where the complete hydraulic system is to be refilled, it is advantageous to first charge the system, to each bleed point in turn, before attempting to expel all air from the system.

Isolating local air pockets

- 5 Use of Girling Brake Service Hose Clamp considerably facilitates the location of air in the system, therefore saving time by locating the hydraulic fault, and saving fluid when servicing the wheel cylinders.

Providing the brake hose is in reasonable condition, damage cannot be caused using the hose clamp, but the use of other tools to clamp the hoses is not recommended as damage may be caused internally to the hose without it being noticed externally.

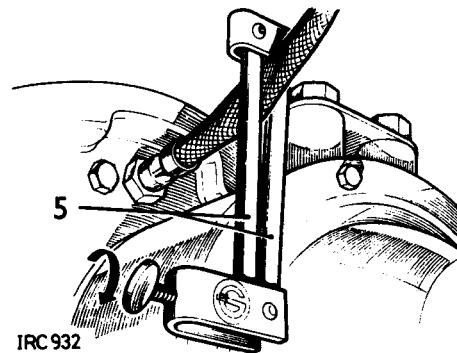

- 6 With clamps fitted on the two front and one rear hose the pedal action should be perfect with no indication of 'sponginess'. If under these circumstances a spongy pedal is apparent, a new or overhauled master cylinder assembly must be fitted and bled and the test repeated.
- 7 If perfect pedal action is obtained with the three hose clamps in position, remove the rear clamp and if the pedal is spongy, the air must be in the rear cylinders. However, if the pedal action is good, remove first one then the other of the two front clamps, repeating the test until the air is located.

Wheel cylinder—servicing

- 8 For wheel cylinder servicing only the appropriate hose need be clamped. This keeps the loss of fluid to a minimum and after the service is satisfactorily completed, only the affected parts require bleeding.

Brake bleeding procedure

- 9 Slacken off the brake shoe adjusters on each wheel to minimise wheel cylinder volume.
- 10 Attach a bleed tube to the bleed nipple farthest from the master cylinder. Submerge the tube free end in brake fluid in a transparent container.
- 11 Slacken the bleed nipple a half-turn.

- 12 Push down the brake pedal through the full stroke; follow with three short rapid strokes then allow the pedal to fully return. Pause for four or five seconds before commencing the next pedal stroke.

NOTE: On dual braking systems only, do not use full pedal travel as this may decentralise the shuttle valve plunger in the brake failure switch. Operate the pedal slowly. If during the bleeding procedure the plunger operates the switch and the warning light is on, the bleedscrew must be closed and the bleedscrew at the other end of the car opened (if bleeding the front brakes, open a bleedscrew on a rear brake and vice versa).

A steady pressure must then be applied to the pedal until the light goes out, when the pressure must be released immediately and the bleedscrew closed. Otherwise the piston will move too far in the opposite direction and require resetting again.

- 13 Repeat the procedure until fluid discharged from the bleed tube is free of air, then tighten the bleed nipple during a pedal downstroke.
- 14 Repeat the procedure on the remaining wheels, commencing and continuing at the next wheel farthest from the master cylinder.
- 15 Adjust the brakes. 70.25.03.
- 16 If the system is fitted with servo assistance: Hold foot pressure on the brake pedal and start the engine. If the vacuum system is functioning correctly, the pedal will move towards the board. If no movement is felt, the vacuum system is not operating.

BRAKES

Adjust

70.25.03

General

Two adjusters are provided on each road wheel on 109 models and one adjuster on each wheel on 88 models.

Adjusting procedure

- 1 Apply the transmission brake.
- 2 Raise the applicable wheel.
- 3 Ensure that the wheel is free to rotate, back-off the adjuster(s) as necessary.
- 4 Turn the adjuster(s) until the brake shoe(s) contact(s) the wheel drum.
- 5 Back-off two serrations on the adjuster(s).
- 6 Lower the wheel.

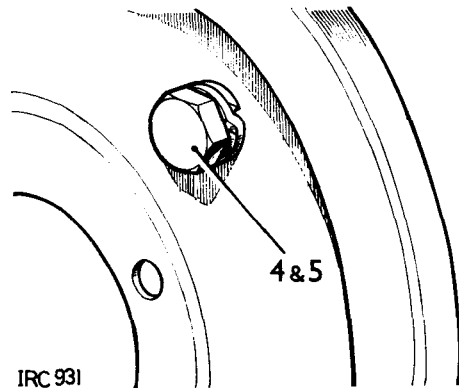

IRC 931

MASTER CYLINDER, Non-servo systems

Remove and refit

70.30.01

Removing

- 1 Disconnect the inlet and outlet pipes from the brake master cylinder.
- 2 Remove the top cover and gasket from the brake pedal bracket.
- 3 Remove the nut and plain washer securing the master cylinder push rod to the brake pedal trunnion.
- 4 Remove the fixings and withdraw the master cylinder from the brake pedal bracket.

Refitting

- 5 Reverse 3 and 4, loosely securing the push rod to the trunnion.
- 6 Adjust the push rod, by rotating, to obtain 1,5 mm (0.062 in.) free play between the push rod and the master cylinder piston.
- 7 Tighten the locknuts.
- 8 Reverse instructions 1 and 2.
- 9 Bleed the brake system. 70.25.02.

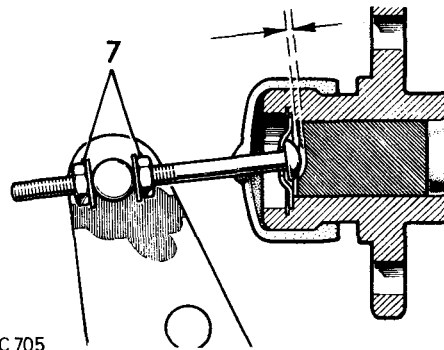

IRC 705

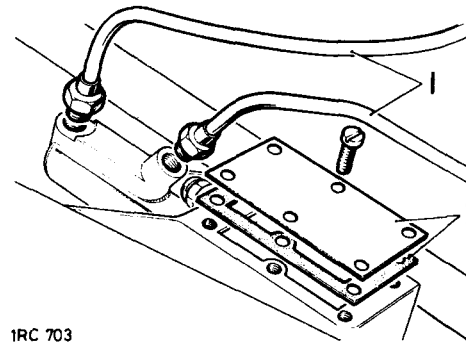

IRC 703

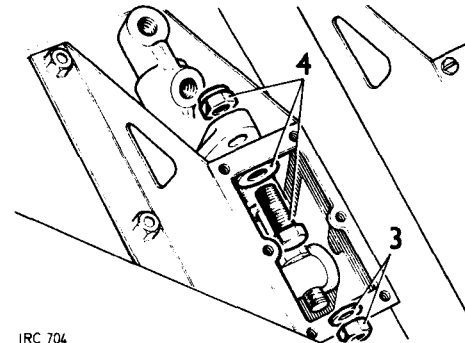

IRC 704

MASTER CYLINDER, Servo Systems

Remove and refit

70.30.01

- 1 Disconnect the outlet pipe from the brake master cylinder.
- 2 Remove the fixings and withdraw the master cylinder complete with reservoir.
- 3 Remove the filler cap and filter, where fitted, from the reservoir and drain all the fluid.
- 4 Using long-nosed pliers, withdraw the plastic cover from the reservoir adaptor bolt.
- 5 Remove the adaptor bolt and withdraw the plain washer, reservoir body, and seal.
- 6 DO NOT attempt to remove the distance piece from the base of the reservoir.

Refitting

- 7 Smear the seal for the reservoir base with Castrol-Girling rubber grease and place it in position.
- 8 Locate the fluid reservoir in position on the master cylinder, and secure with the plain washer and adaptor bolt. Tighten the adaptor bolt to a torque figure of 2,8 to 3,5 kgf. m. (20 to 25 lbf. ft.).
- 9 Reverse instructions 3 and 4.
- 10 Reverse 1 and 2; master cylinder fixings torque load is 2,2 to 2,6 kgf. m. (16 to 19 lbf. ft.).
- 11 Bleed the brake hydraulic system. 70.25.02.

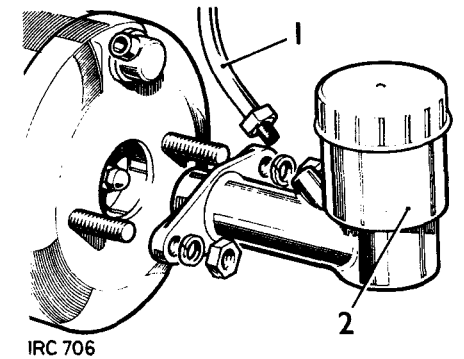

IRC 706

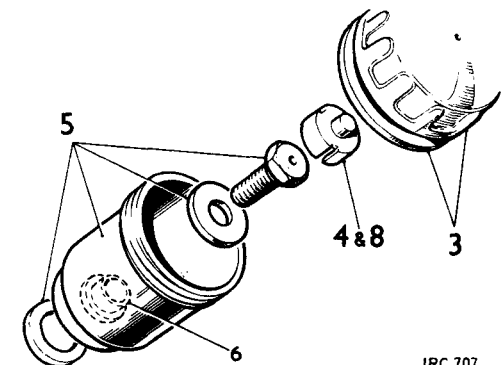

IRC 707

MASTER CYLINDER, Non-servo systems

Overhaul

70.30.02

Dismantling

- 1 Remove the master cylinder. 70.30.01
- 2 Remove the plain washer, nut and rubber cover from the push rod.

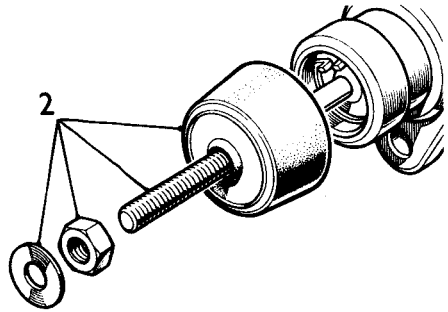

IRC 714

- 3 Remove the circlip.
- 4 Withdraw the push rod and retaining washer.

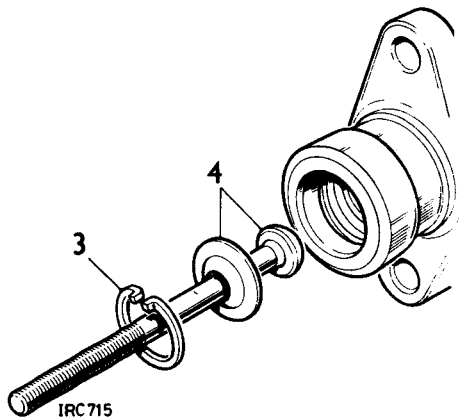

IRC 715

- 5 Withdraw the piston assembly from the master cylinder. If necessary, apply a low air pressure to the outlet port to expel the piston.

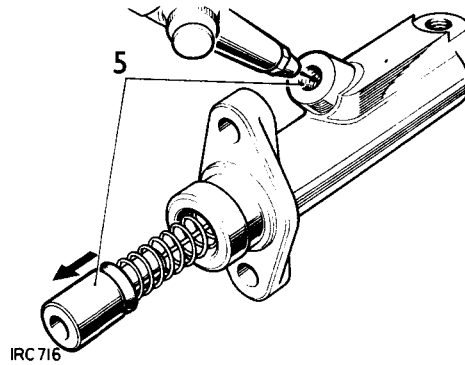

IRC 716

- 6 Prise the locking prong of the spring retainer clear of the piston shoulder.
- 7 Withdraw the piston.
- 8 Remove the piston seal.

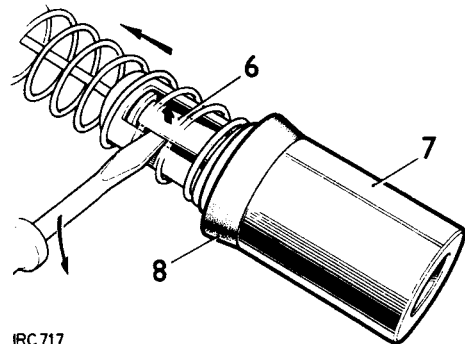

IRC 717

(Non-servo Systems)

- 9 Compress the spring and position the valve stem to align with the larger hole in the spring retainer.
- 10 Withdraw the spring and retainer.

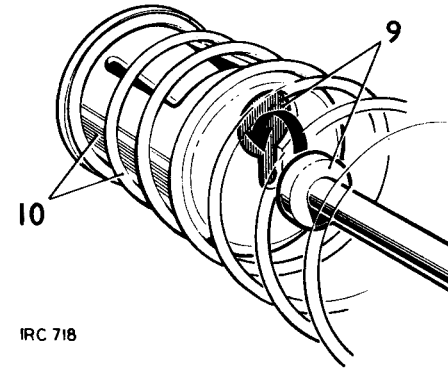

IRC 718

- 11 Slide the valve spring over the valve stem.
- 12 Remove the spring washer and valve seal from the stem.

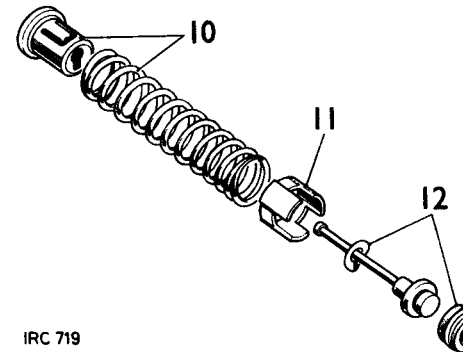

IRC 719

Inspecting

- 13 Clean all components in Girling cleaning fluid and allow to dry.
- 14 Examine the cylinder bore and piston, ensure that they are smooth to the touch with no corrosion, score marks or ridges. If there is any doubt, renew the master cylinder.
- 15 The seals should be replaced with new components. These items are included in the master cylinder overhaul kit.

Assembling

- 16 Smear the seals with Castrol-Girling rubber grease and the remaining internal items with Castrol-Girling Brake and Clutch Fluid.
- 17 Fit the valve seal, flat side first, to the end of the valve stem.
- 18 Place the spring washer, domed side first, over the small end of the valve stem.
- 19 Fit the valve spacer, legs first, and the coil spring.

continued

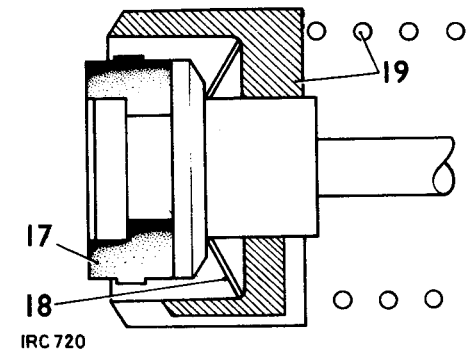

IRC 720

- 20 Insert the retainer into the spring and compress until the stem passes through the keyhole and is engaged in the centre.

(Non-Servo Systems)

- 21 Fit the seal, large diameter last, to the piston.
- 22 Insert the piston into the spring retainer and engage the locking prong.
- 23 Smear the piston with Castrol-Girling rubber grease and insert the assembly, valve end first, into the cylinder.
- 24 Fit the push rod, retaining washer and circlip.
- 25 Smear liberally the inside of the dust cover with Castrol-Girling rubber grease and fit the cover over the push rod and cylinder.
- 26 Fit the locknut and washer to the push rod.
- 27 Refit the master cylinder. 70.30.01.

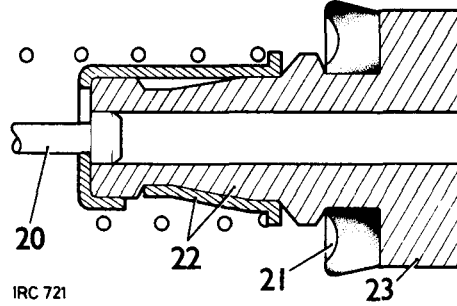

IRC 721

- 3 Prise the locking prong of the spring retainer clear of the piston shoulder.
- 4 Withdraw the piston.
- 5 Remove the piston seal.
- 6 Compress the spring and position the valve stem to align with the larger hole in the spring retainer.

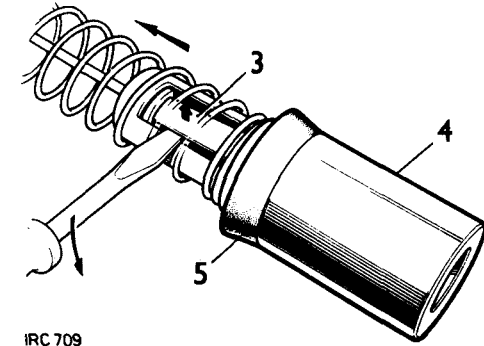

IRC 709

DATA

Master cylinder bore size:

- 88 models
- 109 models

19,05 mm (0.750 in.) diameter
25,4 mm (1.0 in.) diameter.

- 7 Withdraw the spring and retainer.
- 8 Slide the valve spacer over the valve stem.
- 9 Remove the spring washer and valve seal from the stem.

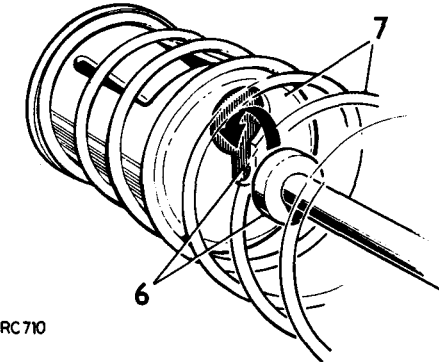

IRC 710

continued

MASTER CYLINDER, Servo systems

Overhaul 70.30.02

Dismantling

- 1 Remove the master cylinder. 70.30.01.
- 2 Withdraw the piston assembly from the master cylinder. If necessary, apply a low air pressure to the outlet port to expel the piston.

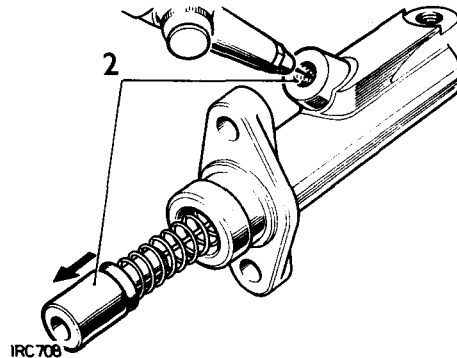

IRC 708

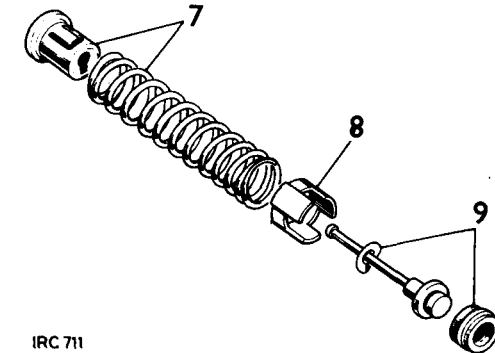

IRC 711

Inspecting

- 10 Clean all components in Girling cleaning fluid and allow to dry.
- 11 Examine the cylinder bore and piston. Ensure that they are smooth to the touch with no corrosion, score marks or ridges. If there is any doubt, fit new replacements.
- 12 The seals should be replaced with new components. These items are included in the master cylinder overhaul kit.

(Servo systems)

Assembling

- 13 Smear the seals with Castrol-Girling rubber grease and the remaining internal items with Castrol-Girling Brake and Clutch Fluid.
- 14 Fit the valve seal, flat side first, to the end of the valve stem.
- 15 Place the spring washer, domed side first, over the small end of the valve stem.
- 16 Fit the valve spacer, legs first, then the coil spring.
- 17 Insert the retainer into the spring and compress until the stem passes through the keyhole and is engaged in the centre.
- 18 Fit the seal, large diameter last, to the piston.
- 19 Insert the piston into the spring retainer and engage the locking prong.
- 20 Smear the piston with Castrol-Girling rubber grease and insert the assembly, valve end first, into the cylinder.
- 21 Liberally smear Castrol-Girling rubber grease inside the piston end of the master cylinder.
- 22 Refit the master cylinder. 70.30.01.

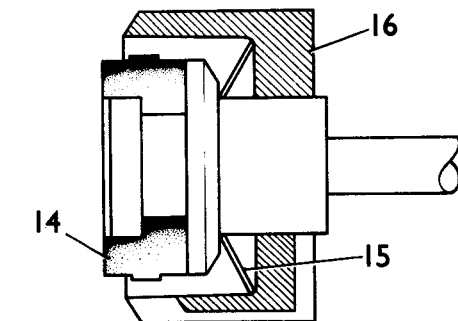

IRC 712

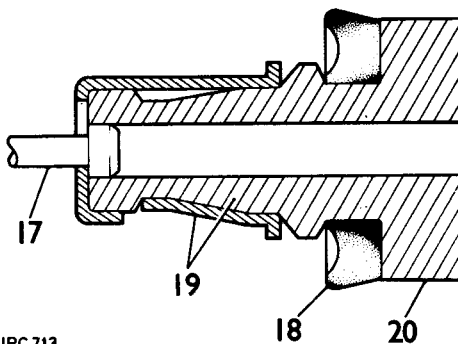

IRC 713

MASTER CYLINDER, Dual systems

Remove and refit 70.30.08

Removing

- 1 Disconnect the brake pipes.
- 2 Remove the fixings at the flange.
- 3 Withdraw the master cylinder and fluid reservoir complete.

Refitting

- 4 Reverse 2 and 3. Torque loading 2,2 to 2,6 kgf. m. (16 to 19 lbf. ft.).
- 5 Connect the brake pipes.
- 6 Bleed the brakes. 70.25.02.

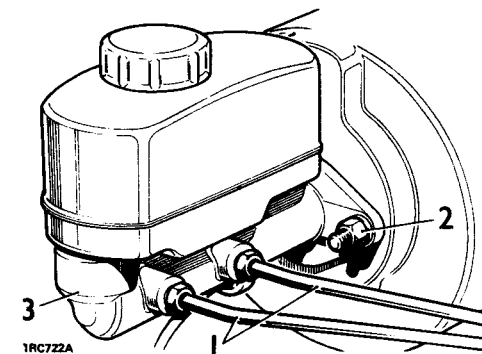

DATA

Master cylinder bore size:

109 models

25,4 mm (1.0 in.) diameter.

MASTER CYLINDER, Dual systems**Overhaul****70.30.09****Dismantling**

- 1 Remove the master cylinder and fluid reservoir complete. 70.30.08.
- 2 Remove the reservoir fixing screws.
- 3 Pivot the reservoir front end aside to expose the master cylinder front inlet bore.

NOTE: Do not attempt to remove completely the reservoir which is retained by an internal fixing at the rear inlet bore.

- 4 Withdraw the oil seal ring.

- 5 Unscrew the tipping valve assembly retainer.
- 6 Lift out the tipping valve assembly.
- 7 Remove the retaining circlip and withdraw the spring.
- 8 Withdraw the tipping valve from the seal plate.
- 9 Withdraw the outer piston.
- 10 Remove and discard the oil seal.
- 11 Withdraw the piston spring.
- 12 Withdraw the inner piston and valve assembly.
- 13 Prise the spring retainer locking prong clear of the piston shoulder and withdraw the piston and spring.
- 14 Remove and discard the oil seal.

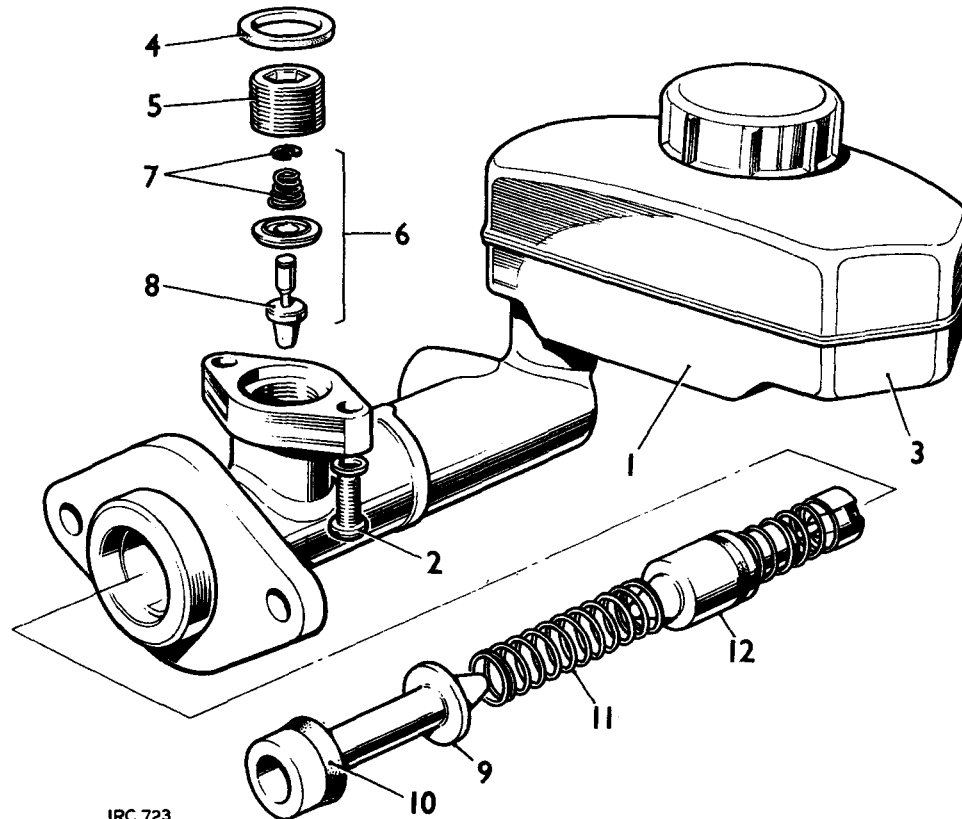

IRC 723

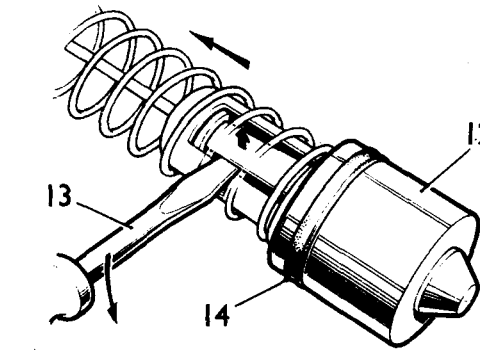

IRC 724

- 15 Position the valve stem to align with the larger hole in the valve retainer. Withdraw the retainer.
- 16 Slide the valve spacer over the valve stem. Remove the wave washer and valve seal from the stem.

Inspecting

- 17 Clean all components in Girling cleaning fluid and allow to dry.
- 18 Examine the cylinder bore and pistons, ensure that they are smooth to the touch with no corrosion, score marks or ridges. If there is any doubt, fit new replacements.
- 19 The seals should be replaced. These items are included in the master cylinder overhaul kit.

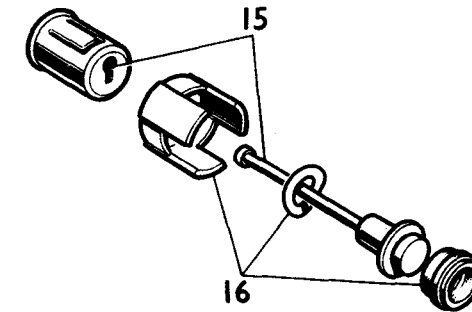
continued

IRC 725

Assembling

- 20 During assembly, smear the seals with Castrol-Girling rubber grease and the remaining internal items with Castrol-Girling Brake and Clutch Fluid.
- 21 Fit the valve seal, flat side first, to the end of the valve stem.
- 22 Fit the wave washer, domed side toward the valve head.
- 23 Fit the valve spacer, legs first.
- 24 Fit the valve retainer.
- 25 Locate the spring over the retainer and squarely seat on the valve spacer.
- 26 Insert the inner piston into the spring and compress until the locking prong on the valve retainer engages in the groove in the piston. If necessary, depress the locking prong to ensure that the free end is fully engaged with the groove shoulder.
- 27 Fit the piston seal.
- 28 Insert the inner piston and valve assembly, valve end first, into the cylinder.
- 29 Reverse 5 to 9. Torque loading for tipping valve retainer is 4,9 to 6,2 kgf. m. (35 to 45 lbf. ft.).
- 30 Reverse 2 to 4. Do not overtighten the reservoir fixings. Torque load 0,3 to 0,4 kgf. m. (2 to 3 lbf. ft.).
- 31 Refit the master cylinder. 70.30.08.

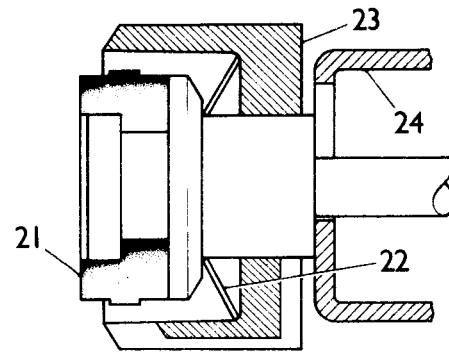

IRC 726

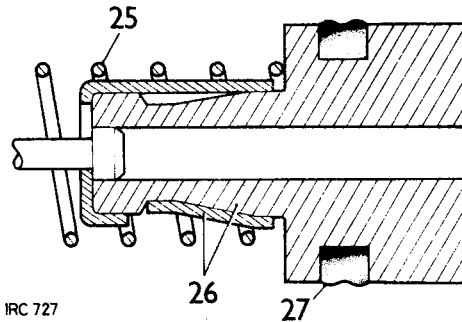

IRC 727

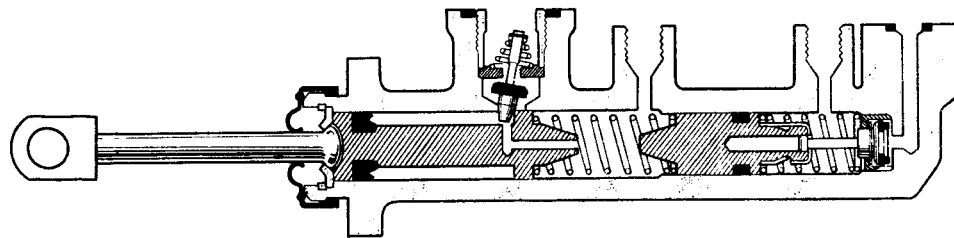

4RC 1065

DATA

Master cylinder bore size:

- | | |
|------------------|------------------------------|
| 88 models | 22,2 mm (0.875 in.) diameter |
| 109 models | 25,4 mm (1.0 in.) diameter |

FLUID RESERVOIR Non-Servo Systems

Remove and refit 70.30.15

Removing

- 1 Lift the bonnet and prop open.
- 2 Make provision to catch the fluid which will be released.
- 3 Disconnect the fluid outlet pipe.
- 4 Remove the clamp fixings.
- 5 Withdraw the reservoir.

Refitting

- 6 Reverse instructions 2 to 5.
- 7 Bleed the hydraulic system. 70.25.02.
- 8 Close the bonnet.

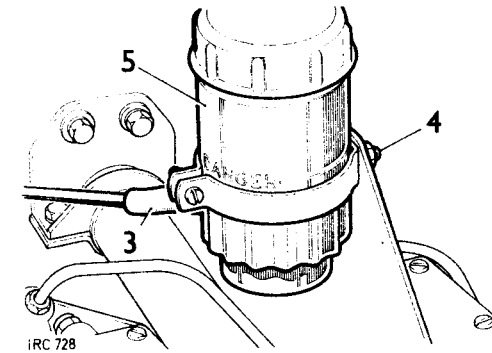

IRC 728

BRAKE PEDAL, Non-servo systems

Remove and refit 70.35.01

Removing

- 1 Lift and prop the bonnet.
- 2 Disconnect the inlet pipe at the master cylinder.
- 3 Disconnect the outlet pipe.
- 4 Disconnect the return spring from the brake pedal.
- 5 Remove the fixings securing the brake pedal bracket to the toe box.
- 6 Carefully withdraw the brake pedal and bracket assembly from the engine compartment, manoeuvring the pedal through the aperture in the toe box.
- 7 Remove the top cover and gasket from the brake pedal bracket.
- 8 Remove the nut and plain washer retaining the master cylinder push rod to the brake pedal trunnion, and push the rod into the master cylinder to clear the trunnion.
- 9 Using a suitable punch, drift out pin, from the pedal shaft.
- 10 Remove pedal shaft.
- 11 Withdraw the brake pedal complete with bushes and trunnion.
- 12 If required, remove the bushes, trunnion and distance piece from the brake pedal.

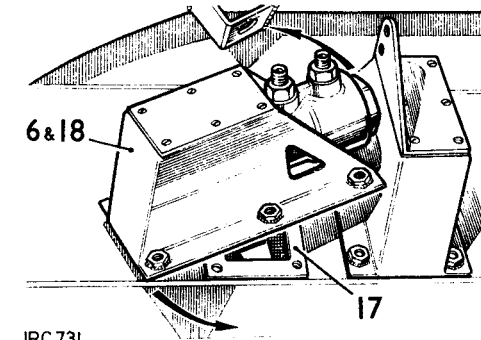

IRC 731

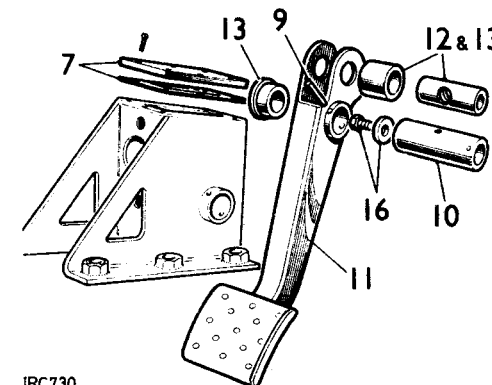

IRC 730

continued

Refitting

- 13 If removed, fit the distance piece, trunnion and bushes to the brake pedal. Lubricate the trunnion and distance piece with general purpose grease on assembly. New pedal bushes must be reamed to 15,9 mm (0.75 in).
- 14 Smear the pedal bushes and shaft with general purpose grease; locate the pedal in position in the bracket and secure with the shaft and pin.
- 15 Locate the master cylinder push rod through the pedal trunnion and fit the locknut and washer.
- 16 Remove the oil plug from the pedal shaft; fill the shaft bore with SAE 20 oil, then replace the plug and joint washer.

(Non-Servo systems)

- 17 Place the gasket in position on the securing flange of the brake pedal bracket. If necessary, use a little Bostik adhesive to retain the gasket.
- 18 Carefully locate the brake pedal and bracket assembly in position on the toe box, manoeuvring the pedal through the aperture in the toe box.
- 19 Secure the brake pedal and bracket assembly to the toe box, ensuring that the gasket remains in position.

Master cylinder and pedal setting, items 20 to 25

- 20 Slacken both nuts on the master cylinder push rod.
- 21 Check the pedal setting which should be 158 mm (6.250 in.) with the stop light switch depressed to the 'off' position.
- 22 Adjust the pedal stop, as required, to obtain the correct distance.
- 23 Adjust the master cylinder push rod until there is 1,55 mm (0.062 in.) approximately free play between the push rod and the master cylinder piston.

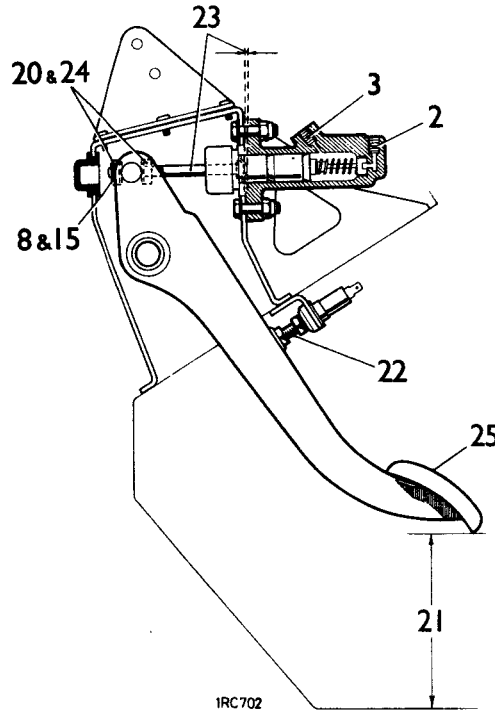

IRC702

- 24 Tighten both locknuts.
- 25 Ensure there is 3,17 mm (0.125 in.) minimum free movement at the pedal before pressure is felt. If necessary, re-adjust the master cylinder push rod to obtain the movement.
- 26 Fit the pedal bracket cover and gasket.
- 27 Reverse instructions 1 to 4.

BRAKE PEDAL, Servo Systems

Remove and refit 70.35.01

Removing

- 1 Disconnect the electrical lead from the stop light switch.
- 2 Disconnect the outlet pipe/s from the master cylinder. Fit a blanking plug to the outlet aperture/s or drain the fluid reservoir, to prevent fluid spillage.

NOTE: The illustration inset shows a tandem master cylinder, where fitted.

- 3 Disconnect the vacuum pipe from the servo unit.
- 4 Remove the toe-board finisher panel.
- 5 Remove the fixings securing the brake pedal bracket to the toe box.
- 6 Withdraw the brake pedal and bracket assembly from the engine compartment, manoeuvring the pedal through the aperture in the toe box.
- 7 Disconnect the brake pedal return spring.
- 8 Remove the split pin and pivot pin from the brake pedal to servo coupling.
- 9 Using a suitable punch, drift out pin from the pedal shaft.
- 10 Remove the pedal shaft.

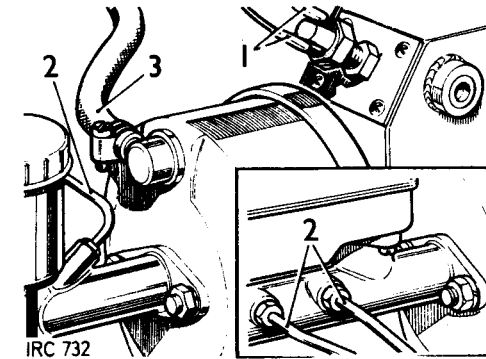
continued

IRC 732

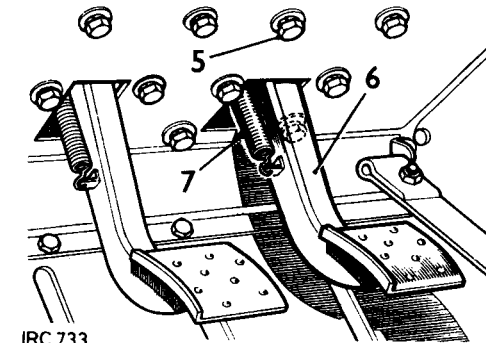

IRC 733

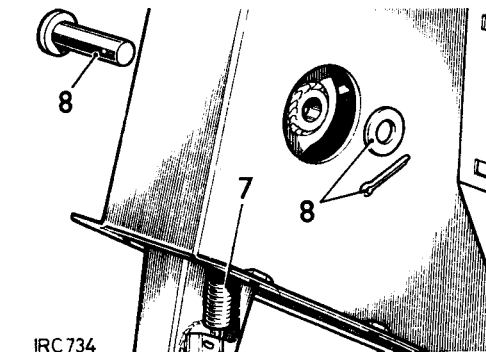

IRC734

(Servo Systems)

- 11 Withdraw the brake pedal complete with bushes.
- 12 If required, remove the bushes from the pedal.

Refitting

- 13 If removed, fit the bushes to the brake pedal. New bushes must be reamed to 15,9 mm (0.75 in).
- 14 Reverse instructions 7 to 10, using general purpose grease to lubricate moving parts.
- 15 Apply a waterproof sealant between the joint flanges of the pedal bracket and the toe box.
- 16 Reverse instructions 1 to 6.
- 17 Check, and if necessary, adjust the brake pedal switch located on the pedal box top cover to operate at 19mm to 25mm (0.750 in. to 1 in.) of pedal movement.
- 18 Bleed the complete braking system. 70.25.02.

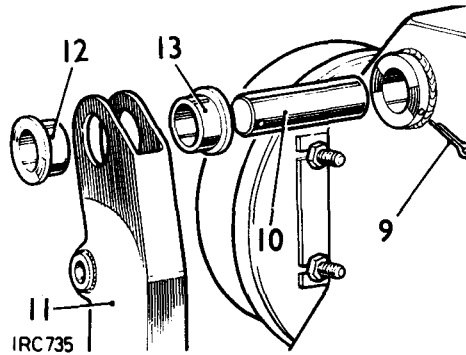

BRAKE SHOES - 88 models

Remove and refit
 Front shoes 70.40.02
 Rear shoes 70.40.03

Removing

- 1 Remove the road wheel.
- 2 Remove the brake drum. 70.10.02 or 70.10.03 as applicable.
- 3 Remove the leading shoe pull-off spring.
- 4 Remove the trailing shoe anchor plate.
- 5 Withdraw the brake shoes together from the pivot end first; part them by disconnecting the return spring.
- 6 Retain the pistons in the wheel cylinder, using a rubber band.
- 7 If required, re-line the brakes. 70.40.10.

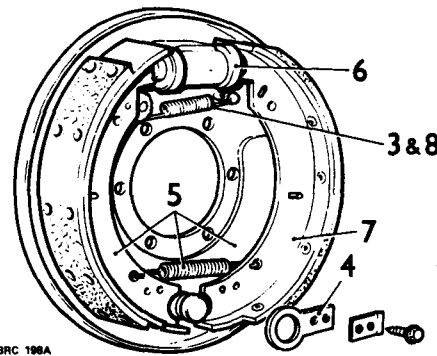

Refitting

- 8 Reverse 2 to 6, refitting the leading shoe pull-off spring with its longest extremity hooked over the post on the shoe web.
- 9 Adjust the brakes fully on, then back off two serrations on the adjuster.
- 10 Fit the road wheel.

DATA

Brake shoe width

38 mm (1.5 in.)

FRONT BRAKE SHOES – 109 models

Remove and refit 70.40.02

Removing

- 1 Remove the road wheel.
- 2 Remove the brake drum. 70.10.02.
- 3 Release the brake shoes and pull-off springs by levering the trailing edges away from the wheel cylinders.
- 4 Retain the pistons in the wheel cylinders, using a rubber band.
- 5 If required, re-line the brake shoes. 70.40.10.

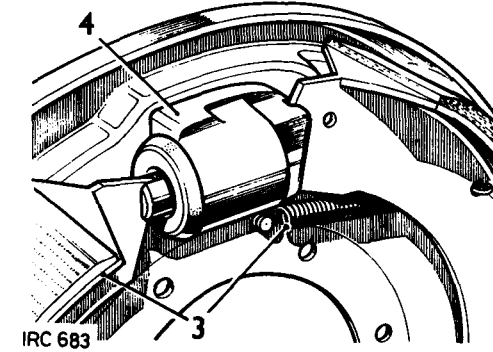

Refitting

NOTE: Ensure that the correct width of brake shoe is fitted as follows:

109 models with 4-cylinder engines – 57 mm (2.250 in.) wide; 109 models with 6-cylinder engines – 76 mm (3.0 in.) wide.

- 6 Reverse instructions 2 to 4.
- 7 Adjust the brakes fully on, then back-off two serrations on the adjusters.
- 8 If the brake shoe steady posts have been disturbed, reset as follows, items 9 to 11.
- 9 Screw back the steady posts clear of the brake shoes and apply the brakes.
- 10 Screw in the steady posts to contact the brake shoes then secure.
- 11 Do not tilt the brake shoes by screwing in the steady posts too far.
- 12 Fit the road wheel.

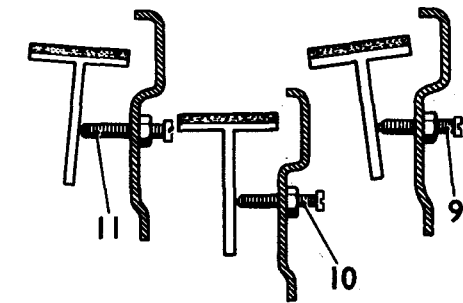

DATA

Brake shoe width
 4 cylinder engine models
 6 cylinder engine models

57 mm (2.250 in.)
 76 mm (3.0 in.)

REAR BRAKE SHOES – 109 models

Remove and refit 70.40.03

Removing

- 1 Remove the road wheel.
- 2 Remove the brake drum. 70.10.03.
- 3 Release the brake shoes by levering the shoes away from the pivot.
- 4 Disconnect the springs.
- 5 Retain the pistons in the wheel cylinder, using a rubber band.
- 6 If required, re-line the brake shoes. 70.40.10.

Refitting

- 7 Reverse instructions 2 to 4.
- 8 Adjust the brakes fully on, then back-off two serrations on the adjuster.
- 9 Fit the road wheel.

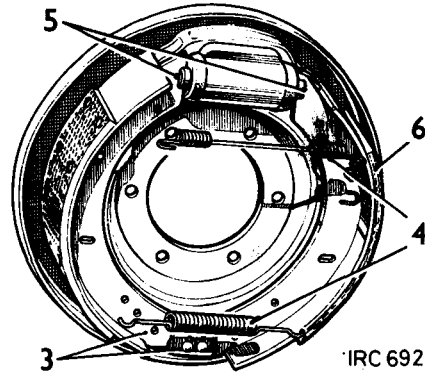

BRAKE LININGS

Remove and refit 70.40.10

Removing

- 1 Remove the brake shoes.
- 2 Remove the old linings from the shoes by shearing the riveted end of the rivets.

NOTE: Brake shoes fitted with bonded linings: If the shoes incorporate rivet holes, the bonded linings can be removed and riveted linings can be fitted in their place. If the shoes are not pre-drilled, replacement shoe and lining assemblies must be fitted.

Refitting

- 3 Attach the new linings to the shoes, commencing at the centre and working outwards, but peen the rivets only sufficient to locate the linings.
- 4 With all the rivets loosely fitted, fully secure, commencing from the centre.
- 5 Chamfer both ends of each lining.
- 6 Fit the brake shoes.

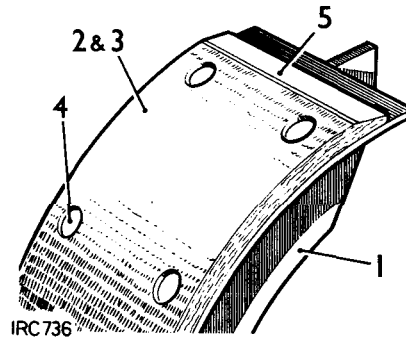

TRANSMISSION BRAKE, HAND LEVER AND LINKAGE

Remove and refit 70.45.01

Removing

CAUTION: Before commencing work on the hand brake mechanism, chock the road wheels to prevent the vehicle moving.

- 1 From under the vehicle, disconnect the hand brake expander rod from the relay lever.
- 2 Remove the relay lever fixings.
- 3 LHS models—Remove the fixings between the hand brake cross-shaft and the R.H. chassis member.
- 4 Remove the fixings securing the hand brake lever to the chassis.
- 5 Remove the hand brake assembly complete from the vehicle, withdrawing the lever grip carefully through the rubber draught excluder in the front of the seat box.
LHS models—To facilitate removal, release the hand brake lever to ratchet fixings and withdraw the cross-shaft and lever separately.
- 6 LHS models—If required, remove the split housings from the cross-shaft support brackets.
- 7 Remove the felt dust seals and self-lubricating bushes supporting the hand brake cross-shaft.

continued

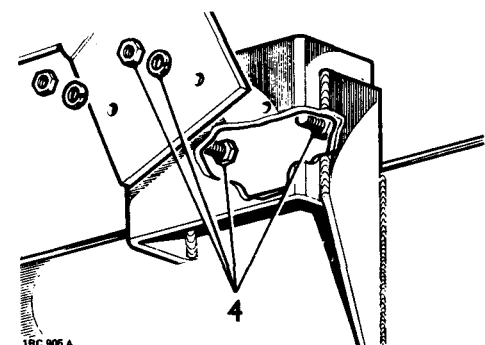
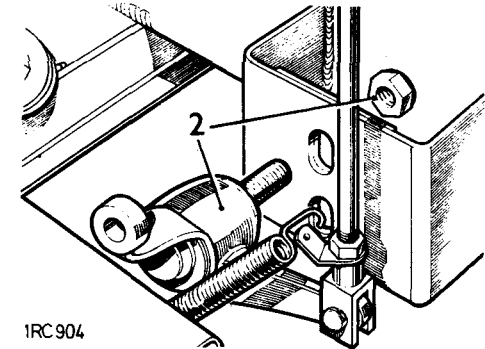
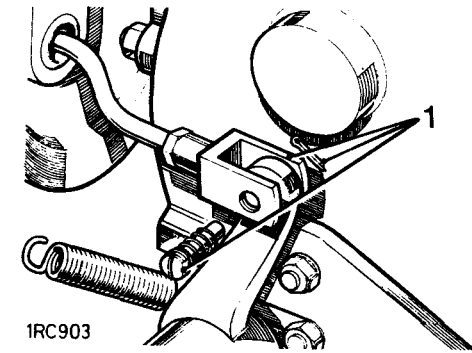
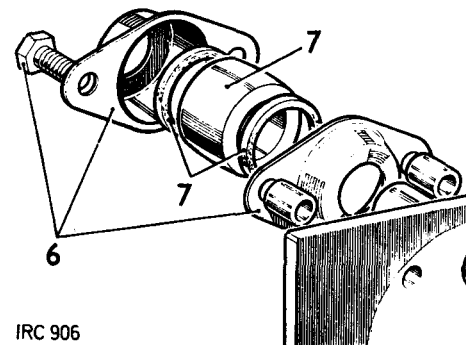

- 8 Remove the brake catch pin, catch and distance pieces.
- 9 RHStg models—Remove the fulcrum pin, ratchet fixings and ratchet from the hand brake lever.
- 10 Unscrew the plunger and withdraw the spring, washer and the plunger rods.
- 11 If required, remove the relay lever and spindle. If necessary, press the bush from the lever.

Refitting

- 12 If removed, fit the bush to the relay lever and fit the relay lever and spindle to the chassis.

NOTE: The bore size of a new relay lever bush is 19,088 mm—0,0254 mm (0.7515 in.—0.001 in.).

- 13 Reverse instructions 1 to 11; lubricate the cross shaft bearings with general purpose grease.
- 14 Set the hand brake linkage at the vertical adjuster rod, so that the hand brake has one or two clicks free movement in the 'off' position.

Key to hand brake lever arrangement, RH Steering

- | | | |
|----|--|--|
| 1 | Hand brake lever | |
| 2 | Plunger rod, upper | |
| 3 | Plunger rod, lower | |
| 4 | Washer for plunger spring | |
| 5 | Spring for plunger rod | |
| 6 | Plunger | |
| 7 | Ratchet for hand brake | |
| 8 | Bolt ($\frac{3}{8}$ in UNF x 1 $\frac{1}{4}$ in long) | } Fixing lever to ratchet |
| 9 | Plain washer | |
| 10 | Self-locking nut ($\frac{3}{8}$ in UNF) | |
| 11 | Brake catch | |
| 12 | Pin | |
| 13 | Distance piece | } Fixing catch |
| 14 | Plain washer | |
| 15 | Split pin | |
| 16 | Pin for hand brake adjuster rod | |
| 17 | Plain washer | } Fixing pin to hand brake lever |
| 18 | Split pin | |
| 19 | Fulcrum pin for hand brake lever | |
| 20 | Plain washer | } Fixing pin to ratchet |
| 21 | Spring washer | |
| 22 | Split pin | } and lever |
| 23 | Bolt ($\frac{3}{8}$ in UNF x $\frac{7}{8}$ in long) | |
| 24 | Spring washer | } Fixing hand brake lever to chassis frame |
| | Nut ($\frac{3}{8}$ in UNF) | |

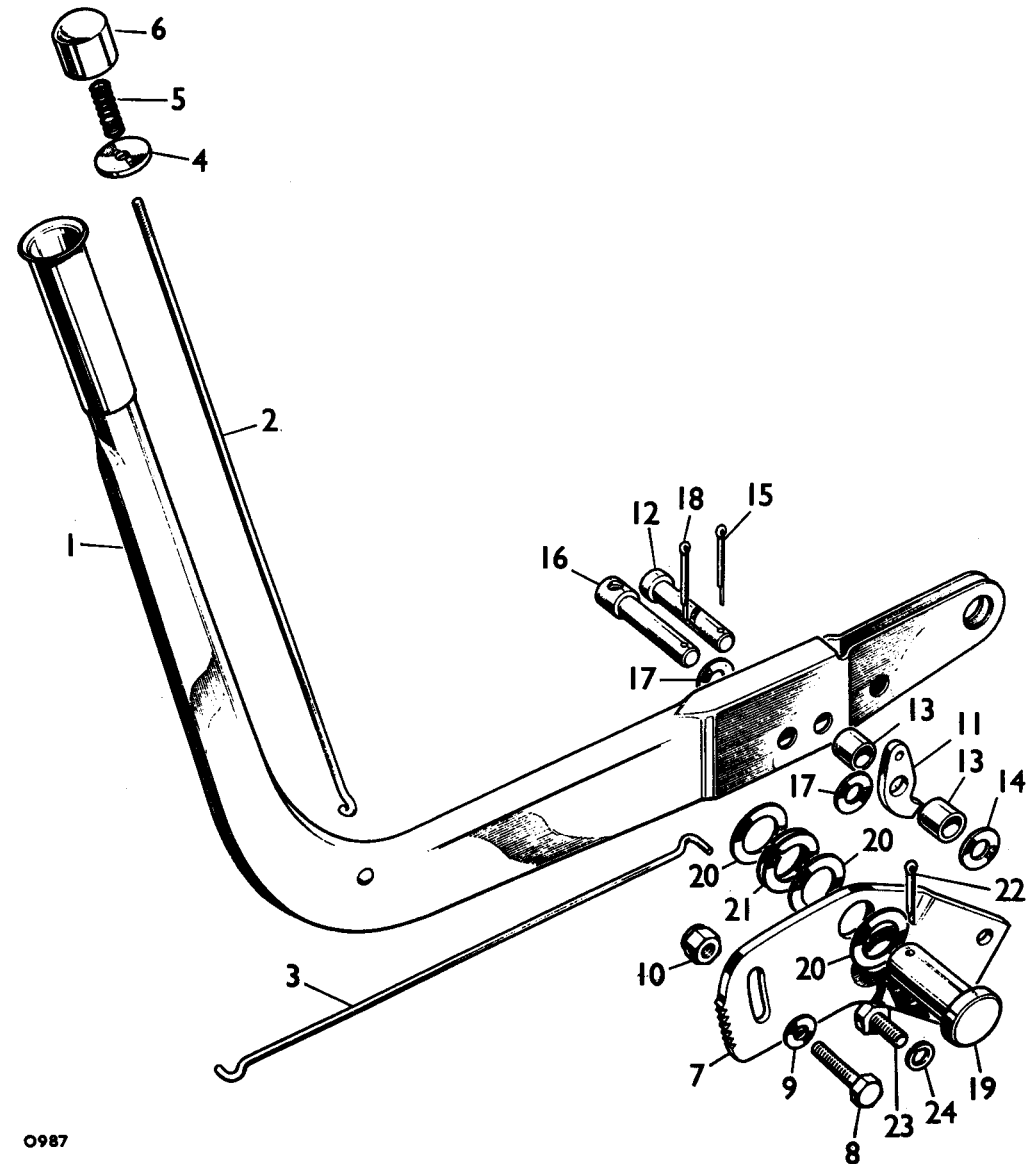

0987

Key to hand brake lever arrangement LH Steering

- | | | | |
|----|-----------------------------|----|-------------------|
| 1 | Housing—cross shaft bearing | 24 | Clevis pin |
| 2 | Bolts | 25 | Fork—clevis |
| 3 | Spring washer | 26 | Split pin |
| 4 | Felt ring | 27 | Spring anchor |
| 5 | Bearing—cross shaft | 28 | Nut |
| 6 | Distance piece | 29 | Rod |
| 7 | Support plate | 30 | Nut—self-locking |
| 8 | Split pin | 31 | Clevis pin |
| 9 | Pin—adjuster rod | 32 | Split pin |
| 10 | Plain washer | 33 | Plain washer |
| 11 | Spring washer | 34 | Washer |
| 12 | Bolt | 35 | Ratchet |
| 13 | Cross shaft | 36 | Bolt |
| 14 | Nut—self-locking | 37 | Plain washer |
| 15 | Plate washer | 38 | Distance piece |
| 16 | Washer | 39 | Pawl |
| 17 | Shaft | 40 | Plunger rod—lower |
| 18 | Relay lever | 41 | Plunger rod—upper |
| 19 | Bush | 42 | Hand brake lever |
| 20 | Washer | 43 | Washer |
| 21 | Circlip | 44 | Spring |
| 22 | Spring anchor | 45 | Plunger |
| 23 | Spring | | |

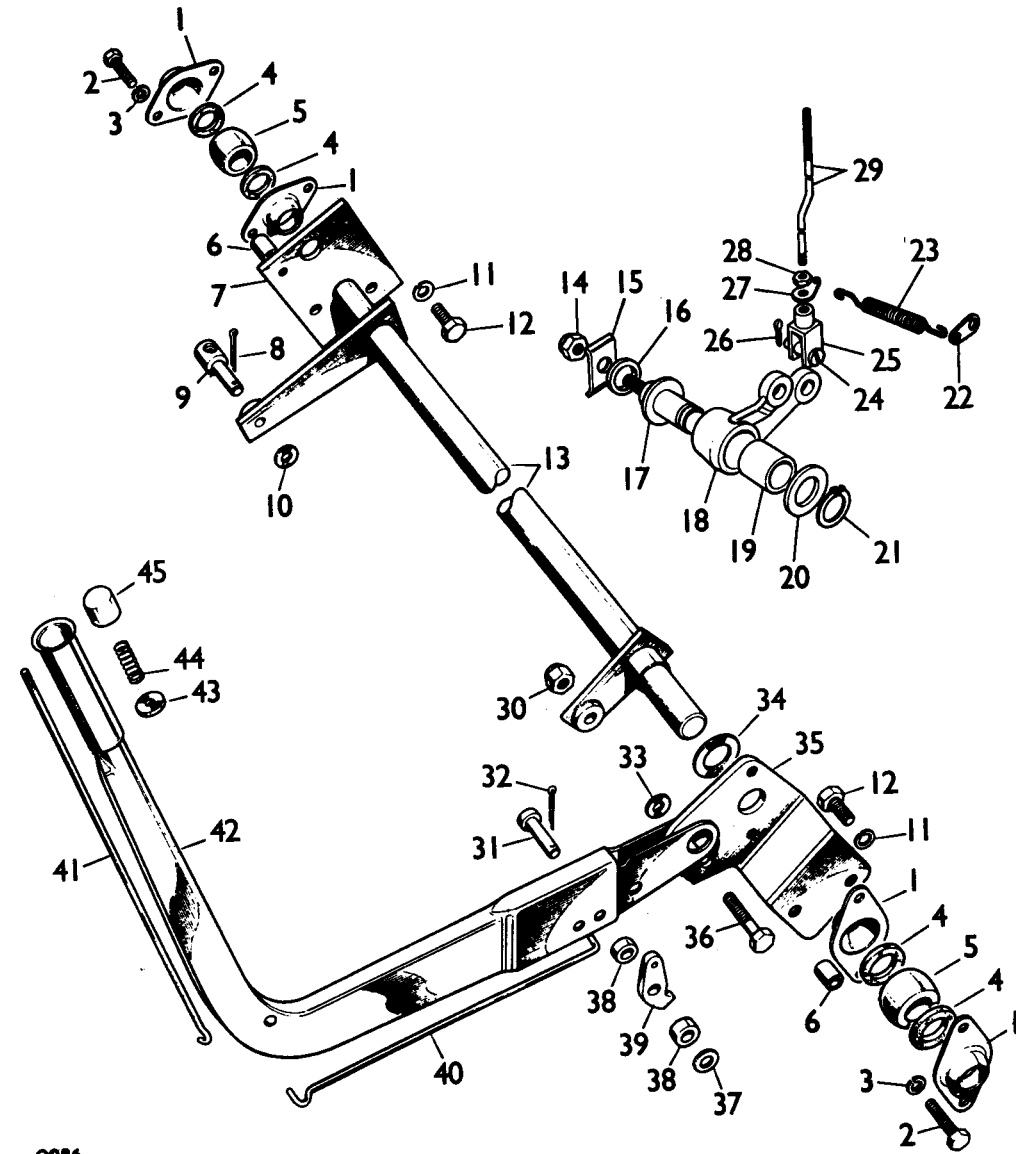

0986

TRANSMISSION BRAKE ASSEMBLY

Adjust. Instructions 36 to 39 70.45.09
 Remove and refit Instructions 1 to 39 70.45.16

TRANSMISSION BRAKE SHOES

Remove and refit Instructions 1 to 7, and 32 to 39 70.45.18

Removing

NOTE: Brake shoe components are accessible after removing the brake drum, which can be detached from the gearbox output flange and pushed back over the propeller shaft.

- 1 Chock the road wheels.
- 2 Disconnect the brake return spring.
- 3 Remove the expander rod fork fixings.
- 4 Disconnect the expander rod from the relay lever, and remove the propeller shaft on the 109 in Land-Rover.
- 5 Remove the fixings and withdraw the brake drum.
- 6 Remove the brake shoes together with the pull-off springs.
- 7 Separate the shoes by detaching the springs.
- 8 Withdraw the dust excluder.
- 9 Remove the expander unit fixing plates.
- 10 Withdraw the expander unit.
- 11 Remove the spring clip from the expander unit.
- 12 Withdraw the plungers and rollers.
- 13 Withdraw the operating rod.
- 14 Remove the adjuster unit assembly.
- 15 Pull out the adjuster plungers.
- 16 Unscrew the adjuster cone.

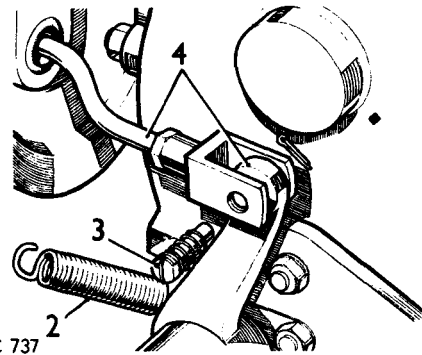

IRC 737

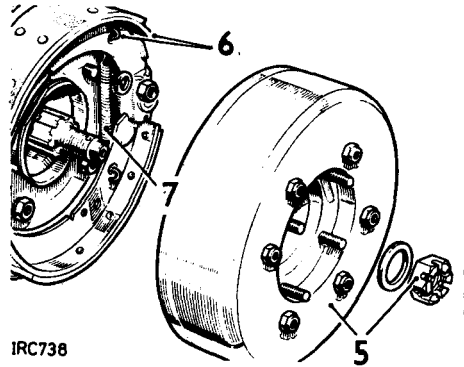

IRC 738

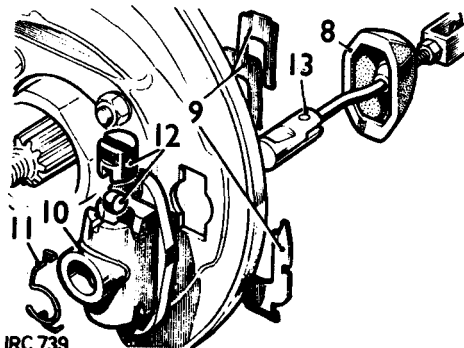

IRC 739

Inspecting

- 17 Clean all components in Girling cleaning fluid and allow to dry.
- 18 Examine all items for obvious wear and replace as necessary.
- 19 Examine the brake drum for scoring and ovality and skim if required. Standard diameter is 228,6 mm (9.0 in.); reclamation limit is 0,75 mm (0.030 in.) oversize.
- 20 If the brake linings are oily, check and if necessary replace the output shaft oil seal, Division 37.
- 21 If required, reline the brake shoes. 70.40.10.

Assembling

- 22 Fit the adjuster unit housing, do not tighten the fixings at this stage.
- 23 Screw in the adjuster cone.
- 24 Grease and refit the adjuster plungers.

NOTE: The two plungers are identical and may be fitted to either bore. Align the chamfered ends of the plungers with the cone on the adjuster.

continued

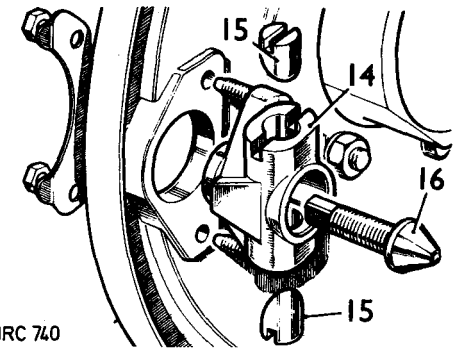

IRC 740

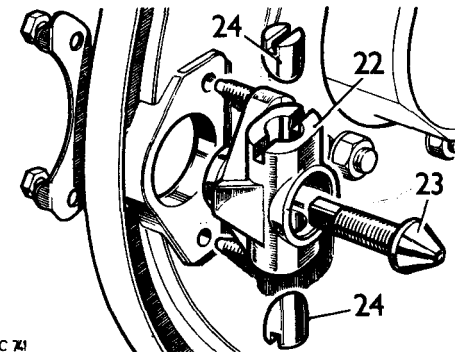

IRC 741

- 25 Grease and fit the expander rod.
- 26 Grease and fit the plungers and rollers.
- 27 Position the adjuster housing on the back plate.
- 28 Fit the packing piece.
- 29 Fit the locking plate.
- 30 Fit the retainer spring.
- 31 Fit the spring clip to the expander unit.
- 32 Fit the brake shoes and pull-off springs together.
- 33 The fully lined end of the lower shoe must be toward the expander housing.
- 34 The fully lined end of the upper shoe must be toward the adjuster housing.
- 35 Reverse instructions 2 to 5.
- 36 Turn the adjuster cone fully in and tighten the fixings.
- 37 Slacken off the adjuster cone two 'clicks'; give the brake a firm application to ensure that the shoes have centralised at the expander end. The brake drum should now be free to rotate.
- 38 Set the hand brake linkage at the vertical adjuster rod, so that the hand brake has one or two clicks free movement in the 'off' position.
- 39 Remove the road wheel chocks.

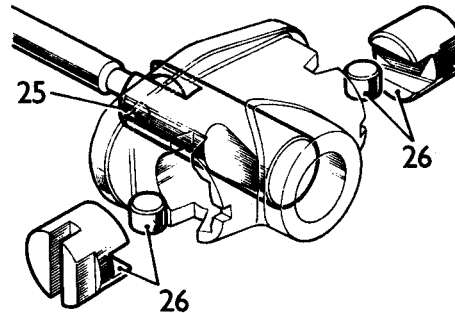

IRC 742

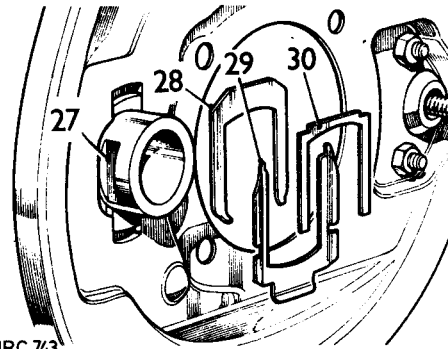

IRC 743

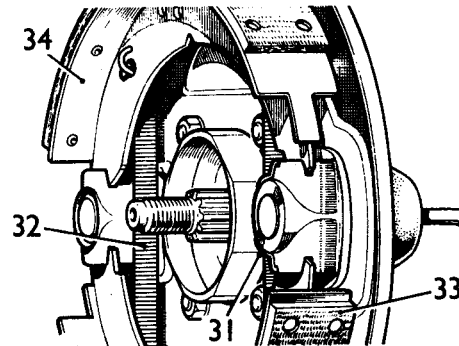

IRC 744

SERVO ASSEMBLY

Remove and refit

70.50.01

Removing

- 1 Remove the brake master cylinder. 70.30.01 or 70.30.08 as applicable.
- 2 Disconnect the vacuum hose from the servo assembly.
- 3 Remove the switch plate.
- 4 Remove the rubber plugs from the pedal box.
- 5 Remove the split pin and withdraw the clevis pin securing the servo rod to the pedal.
- 6 Remove the fixings.
- 7 Withdraw the servo assembly.

Refitting

- 8 Reverse instructions 1 to 7. Torque load for servo fixings is 1,2 kgf. m. (9 lbf. ft.).

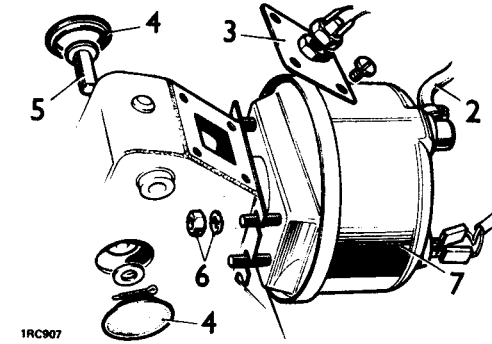

IRC907

VACUUM RESERVOIR TANK - Diesel models with Servo

Remove and refit

70.50.04

Removing

- 1 Remove the union bolt and washers securing the vacuum pipes to the vacuum tank.
- 2 Remove the bolts, washers and nuts securing the vacuum tank brackets to the vehicle.
- 3 Withdraw the vacuum tank and brackets from the vehicle.
- 4 Remove the brackets from the vacuum tank.

Refitting

- 5 Reverse instructions 1 to 4.

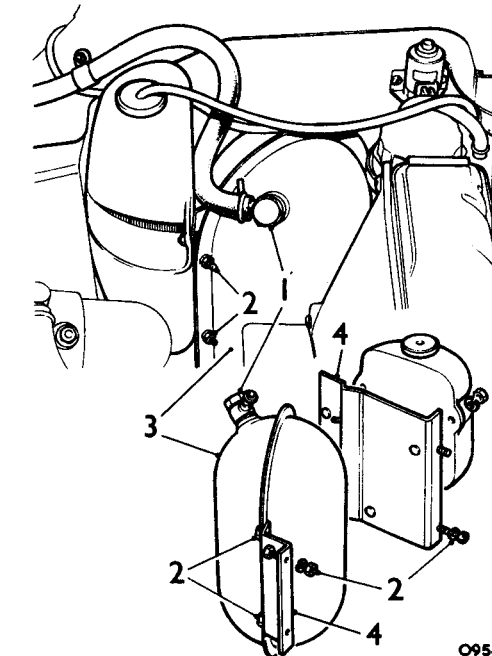

O954

SERVO ASSEMBLY

Overhaul

70.50.06

NOTE: The Supervac servo unit can be serviced, with a kit that is available, without completely dismantling the servo. In the event of the servo developing a major fault, the unit must be renewed.

Dismantling

- 1 Remove the servo. 70.50.01.
- 2 Pull back the dust cover.
- 3 Remove the end cap.
- 4 Withdraw the filter.
- 5 Remove the seal and plate assembly from the front shell recess.
- 6 Remove the non-return valve and grommet.
- 7 **CAUTION:** Do not attempt to remove or adjust the operating rod which is pre-set and locked at the manufacturers.

Reassembling (using the service kit)

- 8 Lubricate the non-return valve grommet with Girling Grease (64949009), and fit to the front shell.
- 9 Fit the new non-return valve into the grommet.
- 10 Smear the new seal and plate assembly with Girling Grease (64949008), and press into the front shell, ensuring the plate faces inwards.
- 11 Fit the new filter into the neck of the diaphragm plate.
- 12 Fit the new end cap.
- 13 Locate the new dust cover over the lugs of the rear shell.
- 14 Fit the servo. 70.50.01.

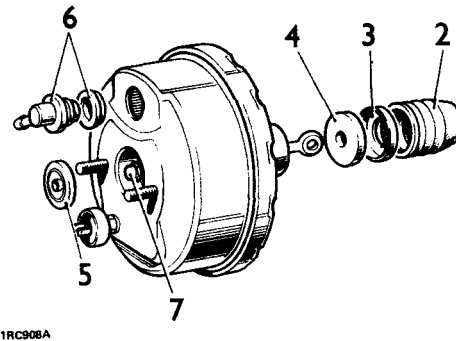

WHEEL CYLINDER, 88 models

Front wheel cylinder

- Remove and refit. Instructions 1 to 5 and 14 to 18 70.60.03
Overhaul. Instructions 6 to 13 70.60.11

Rear wheel cylinder

- Remove and refit. Instructions 1 to 5 and 14 to 18 70.60.18
Overhaul. Instructions 6 to 13 70.60.26

Removing

- 1 Remove the road wheel.
- 2 Remove the brake drum. 70.10.02.
- 3 Remove the brake shoes. 70.40.02.
- 4 Disconnect and seal the brake fluid pipe.
- 5 Remove the wheel cylinder.

Dismantling

- 6 Withdraw the dust covers.
- 7 Withdraw the pistons and seals.
- 8 Withdraw the seal supports.
- 9 Withdraw the spring.
- 10 Remove the bleed screw.

Inspecting

- 11 Clean all components, using Girling cleaning fluid, and allow to dry.
- 12 Inspect the cylinder bore and pistons for corrosion, scores and wear. If any component is not satisfactory, replace the complete wheel cylinder assembly.
- 13 Provide new seals and dust covers from the wheel cylinder overhaul kit.

Assembly

- 14 Lubricate the components, using the recommended Girling brake fluid.
- 15 Reverse 6 to 9. Fit the piston seal with the flat face toward the piston.
- 16 Fit the bleed screw, do not over-tighten. Torque 0,5 to 0,8 kgf. m. (4 to 6 lbf. ft.).

Refitting

- 17 Reverse instructions 1 to 5.
- 18 Bleed the brakes. 70.25.02.

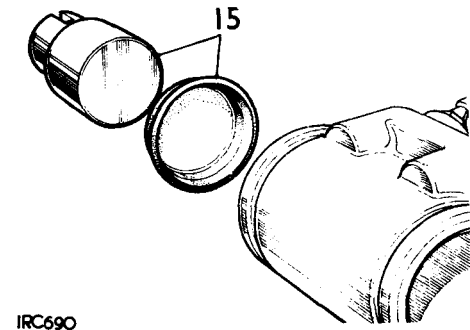
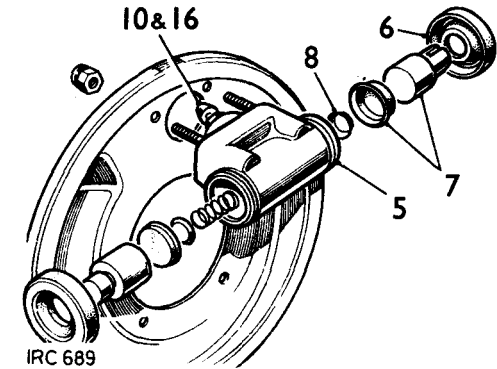

FRONT WHEEL CYLINDERS – 109 models

Remove and refit. Instructions 1 to 5
and 16 and 17 70.60.03
Overhaul. Instructions 6 to 15 70.60.11

Removing

- 1 Remove the road wheel.
- 2 Remove the brake drum. 70.10.02.
- 3 Remove the brake shoes. 70.40.02.
- 4 Disconnect and seal off the brake fluid pipe.
- 5 Remove the bleed screw (lower cylinder only).
- 6 Remove the wheel cylinder.

Dismantling

- 7 Withdraw the dust cover.
- 8 Withdraw the piston and seal.
- 9 Withdraw the spring.

Inspecting

- 10 Clean all components, using Girling cleaning fluid, and allow to dry.
- 11 Inspect the cylinder bore and piston for corrosion, scores and wear. If any component is unsatisfactory, replace the wheel cylinder assembly complete.
- 12 Provide new seals and dust covers from the wheel cylinder overhaul kit.

Assembling

- 13 Lubricate the components, using the recommended Girling brake fluid.
- 14 Reverse instructions 6 to 8. Fit the piston seal with the lipped side away from the slotted end.
- 15 Fit the bleed screw, do not over-tighten. Torque 0,5 to 0,8 kgf. m. (4 to 6 lbf. ft.).

Refitting

- 16 Reverse instructions 1 to 5.
- 17 Bleed the brakes. 70.25.02.

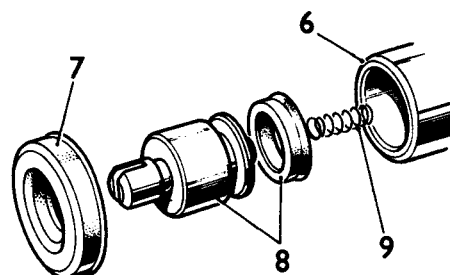

IRC 684A

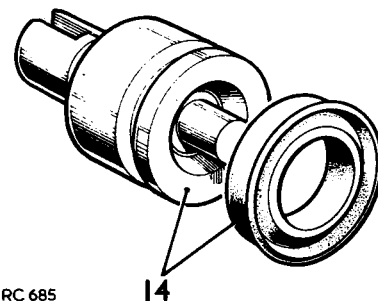

IRC 685

REAR WHEEL CYLINDER – 109 models

Remove and refit. Instructions 1 to 5
and 16 and 17 70.60.18
Overhaul. Instructions 6 to 15 70.60.26

Removing

- 1 Remove the road wheel.
- 2 Remove the brake drum. 70.10.03.
- 3 Remove the brake shoes. 70.40.03.
- 4 Disconnect and seal off the brake fluid pipe.
- 5 Remove the wheel cylinder.

Dismantling

- 6 Withdraw the dust covers.
- 7 Withdraw the pistons and seals.
- 8 Withdraw the spring and seal supports.
- 9 Remove the bleed screw.

Inspecting

- 10 Clean all components, using Girling cleaning fluid, and allow to dry.
- 11 Inspect the cylinder bore and piston for corrosion, scores and wear. If any component is unsatisfactory, replace the wheel cylinder assembly complete.

(109 models)

- 12 Provide new seals and dust covers from the wheel cylinder overhaul kit.

Assembling

- 13 Lubricate the components, using the recommended Girling brake fluid.
- 14 Reverse 6 to 8. Fit the piston seal with the lipped side away from the slotted end.
- 15 Fit the bleed screw, do not over-tighten. Torque 0,5 to 0,8 kgf. m. (4 to 6 lbf. ft.).

Refitting

- 16 Reverse instructions 1 to 5.
- 17 Bleed the brakes. 70.25.02.

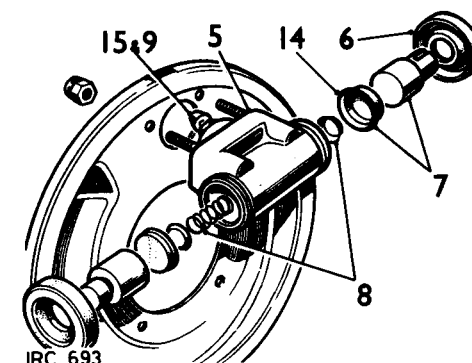

IRC 693

WHEELS AND TYRES

General

74.10.00

Tyres of correct type and dimension form an essential part of vehicle design. Regular tyre inspection and maintenance contributes not only to safety but also to the proper functioning of the vehicle. Road holding, steering and braking can be impaired by incorrect tyre pressure, badly fitted tyres and by worn treads.

Tyres of the same size but of different makes and tread patterns may possess widely varying characteristics. For this reason it is advised that tyres of the same make, type and tread pattern are fitted to all wheels. Tyres of different dimensions, even if paired, must never be fitted or transmission 'wind-up' on four wheel drive will occur. This will stress transmission components.

Where chevron tread type tyres are fitted the apex of the vee must lead in the direction of forward wheel rotation. Attention to this factor is necessary when interchanging wheels.

Refer to Section 04 for wheel and tyre data.

Wheel nuts

Wheel nuts should be evenly tightened to 10,3 to 11,7 kgf m (75 to 85 lbf ft).

Wheel tolerance

Lift

On a truly mounted and revolving wheel the difference between the high and low points measured at any location on either tyre seat should not exceed 2,30 mm (0.090 in.) maximum; 1,50 mm (0.060 in.) desired.

Wobble

The lateral variation measured on the vertical inside face of a flange should not exceed 2,30 mm (0.090 in.) maximum; 1,50 mm (0.060 in.) desired.

BODY REPAIRS

General information

76.00.00

Body panels

- 1 Land Rover body panels are manufactured from a special aluminium-alloy known as 'Birmabright'.
- 2 'Birmabright' melts at a slightly lower temperature than pure aluminium and will not rust nor corrode under normal circumstances. It is work-hardening, but is easily annealed. Exposed to the atmosphere, a hard oxide skin forms on the surface.

Panel beating 'Birmabright'

- 3 'Birmabright' panels and wings can be beaten out after accidental damage then must be annealed, by the application of heat, followed by slow air-cooling; as the melting point is low, heat must be applied slowly and carefully. A practical temperature control is to apply oil to the cleaned surface to be annealed. Play the welding torch on the underside of the cleaned surface and watch for the oil to clear, leaving the surface clean and unmarked; then allow to cool naturally in the air, when the area so treated will again be soft and workable. Do not quench with oil or water. Another method is to clean the surface to be annealed and then rub it with a piece of soap. Apply heat beneath the area, as described above, and watch for the soap stain to clear. Then allow to cool, as for the oil method. When applying the heat for annealing, always hold the torch some little distance from the metal, and move it about, so as to avoid any risk of melting it locally.

Gas welding 'Birmabright'

- 4 A small jet must be used, one or two sizes smaller than would be used for welding sheet steel of comparable thickness. For instance, use a No. 2 nozzle for welding 18 swg (0.048 in.) sheet, and a No. 3 for 16 swg (0.064 in.) sheet.

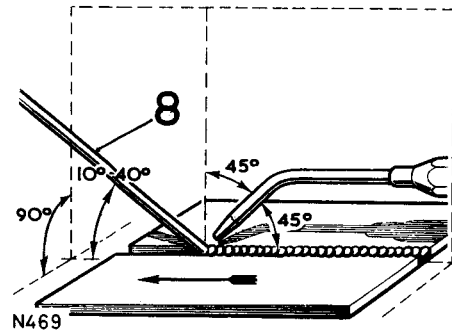
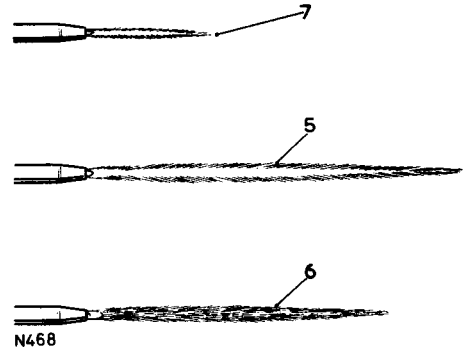

- 5 The flame should be smooth, quiet and neutral and have a brilliant inner core with a well defined, rounded end. The hottest point of the flame is close to the jet, and the flame should have a blue to orange envelope becoming nearly colourless at the end.
- 6 A slightly reducing flame may also be used, that is, there may be a slight excess of acetylene. Such a flame will have a brilliant inner core with a feathery white flame and a blue to orange envelope.
- 7 Do not use an oxydising flame, which has a short pointed inner core bluish white with a bluish envelope.

- 8 Use only 5 per cent magnesium/aluminium welding rod (5 Mg/A). Sifalumin No. 27 (MG.5 Alloy) (Use Sifbronze Special flux with this rod) or a 'Birmabright' offcut sheet. Do not use too wide or thick an offcut or trouble may be experienced in making it melt before the material which is being welded.
- 9 Clean off all grease and paint, dry thoroughly then clean the edges to be welded, and an area at least half an inch on either side of the weld, with a stiff wire scratch-brush or wire wool. Cleanliness is essential. Also clean the welding rod or strip with wire wool.
- 10 A special acid flux must be used, and we recommend 'Hari-Kari' which is obtainable from:
The Midland Welding Supply Co. Ltd.,
105 Lakey Lane,
Birmingham 28, England.
or
Sifbronze Special Flux, which is obtainable from:
Suffolk Iron Foundry (1920) Ltd.,
Sifbronze Works,
Stowmarket, England.
- 11 A small quantity of 'Hari-Kari' may be made into a paste with water, following the directions on the tin, and the paste must be applied to both surfaces to be welded and also to the rod. In the case of Sifbronze Special Flux, use in powder form as directed. Remember that aluminium and its alloys do not show 'red-hot' before melting, and so there is nothing about the appearance of the metal to indicate that it has reached welding temperature. A little experience will enable the operator to gauge this point, but a useful guide is to sprinkle a little sawdust over the work; this will sparkle and char when the right temperature is approached; a piece of dry wood rubbed over the hot metal will sparkle at the point of contact.

- 12 As the flux used is highly acid, it is essential to wash it off thoroughly immediately after a weld is completed. The hottest possible water should be used, with wire wool or a scratch-brush. Very hot soapy water is good, because of the alkaline nature of the soap, which will tend to 'kill' the acid.
- 13 It is strongly recommended that a few welds are made on scrap metal before the actual repair is undertaken if the operator is not already experienced in welding aluminium and its alloys.
- 14 The heat of welding will have softened the metal in the area of the repair, and it may be hardened again by peening with a light hammer. Many light blows are preferable to fewer heavy ones. Use a 'dolly' or anvil behind the work to avoid denting and deformation, and to make the hammering more effective. Filing of surplus metal from the weld will also help to harden the work again.

Welding tears and patching

- 15 If a tear extends to the edge of a panel, start the weld from the end away from the edge and also at this point drill a small hole to prevent the crack spreading, then work towards the edge.
- 16 When welding a long tear, or making a long welded joint, tack the edges to be welded at intervals of from 50 to 100 mm (2 in. to 4 in.) with spots. This is done by melting the metal at the starting end and fusing into a small amount of the filler rod, repeating the process at the suggested intervals. After this, weld continuously along the joint from right to left, increasing the speed of the weld as the material heats up.
- 17 After the work has cooled, wash off all traces of flux as described previously, and file off any excess of build-up metal.
- 18 When patching, cut the patch to the correct shape for the hole to be filled, but of such size as to leave a gap of 0,8 mm (0.030 in.) between it and the panel, and then weld as described above. Never apply an 'overlay' patch.

continued

Electric welding

19 **CAUTION:** The battery earth lead must be disconnected before commencing electric welding, otherwise the alternator will be damaged.

20 At the Rover Factory the 'Argon-Arc' process is used, all atmospheric oxygen being excluded from the weld by the Argon gas shield. For all body repair work normally undertaken by a Distributor's or Dealer's service department, the gas welding method is sufficient and quite satisfactory.

Spot-welding

21 Spot-welding is largely used in the manufacture of Land-Rover bodies, but this is a process which can only be carried out satisfactorily by the use of the proper apparatus. Aluminium and its alloys are very good conductors of heat and electricity, and thus it is most important to maintain the right conditions for successful spot-welding. The correct current density must be maintained, and so must the 'dwell' of the electrodes. Special spot-welding machines have been developed, but they are expensive, and though the actual work can be carried out by comparatively unskilled labour, supervision and machine maintenance must be in the hands of properly qualified persons.

Riveting

22 Where both sides of the metal are accessible and it is possible to use an anvil or 'dolly', solid aluminium rivets may be used, with a suitable punch or 'pop' to ensure clean, rounded heads on the work. For riveting blind holes, 'pop-rivets' must be used. These are inserted and closed by special 'Lazy-Tong' 'pop-rivet' pliers.

Painting 'Birmabright'

23 Refer to the procedure detailed in Paintwork Section 78.

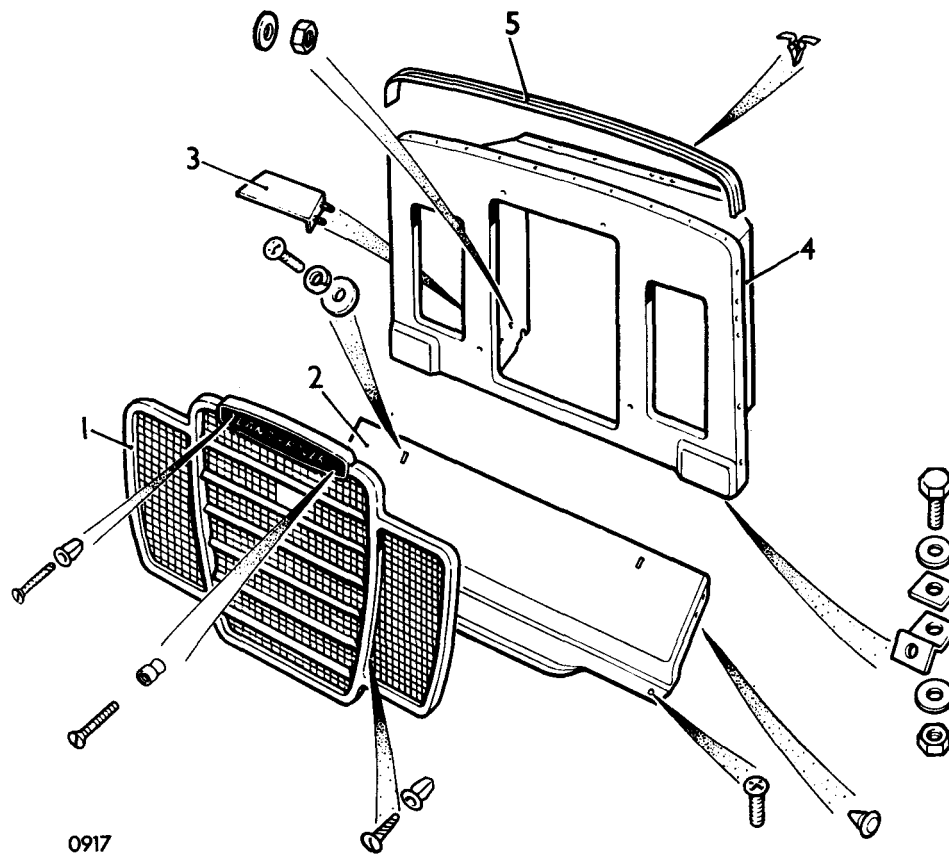

Radiator grille, front apron and grille panel

Key

- 1 Radiator grille.
- 2 Front apron panel
- 3 Horn protector plate
- 4 Radiator grille panel
- 5 Bonnet rest strip

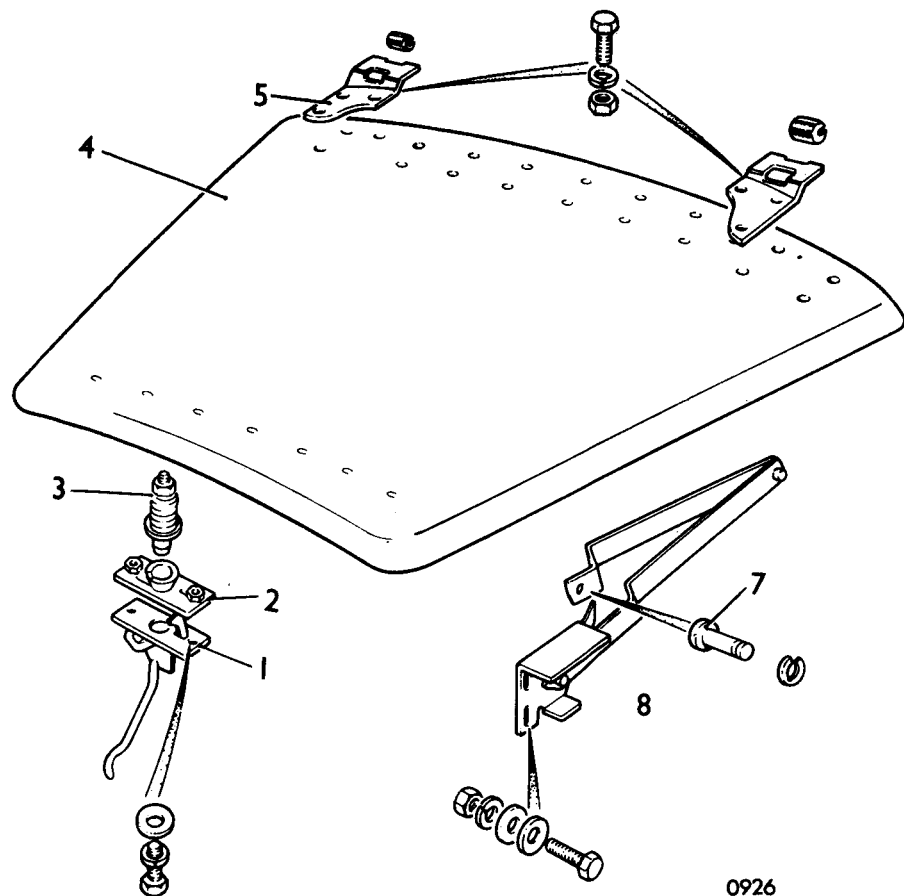

0926

Bonnet

Key

- 1 Bonnet control
- 2 Washer plate
- 3 Striker pin
- 4 Bonnet
- 5 Hinge
- 6 Bush — bonnet hinge
- 7 Pivot pin
- 8 Bonnet prop

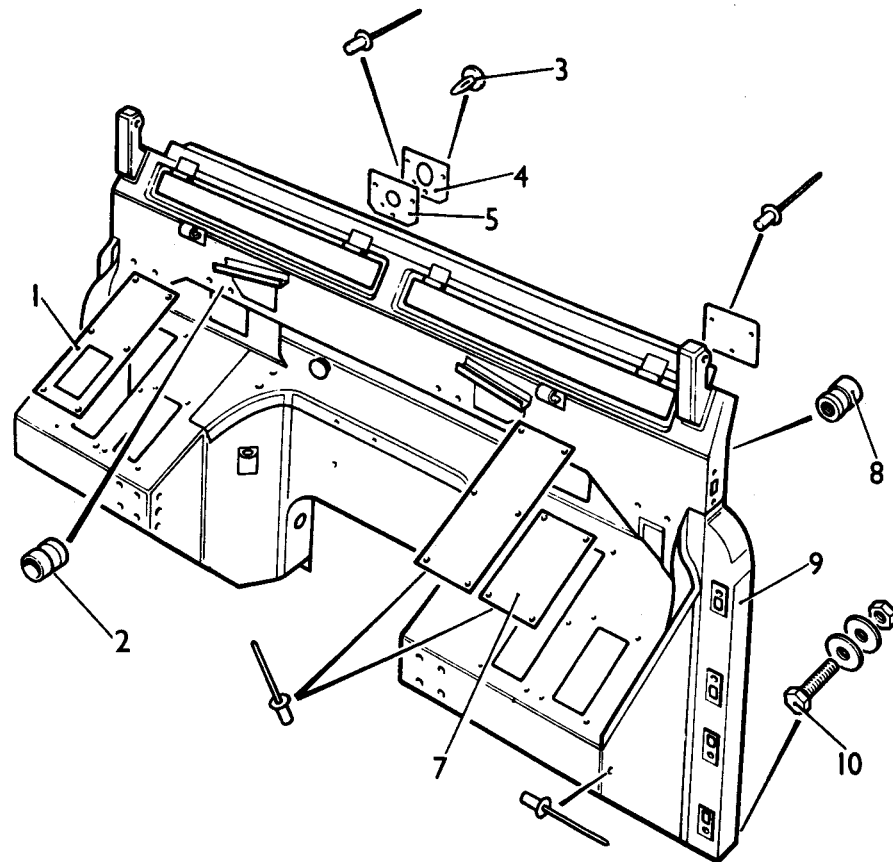

0920

Dash

Key

- 1 Pedal hole cover plate
- 2 Nutserts
- 3 Drive fasteners
- 4 Backing plate for seal
- 5 Seal
- 6 Pedal hole cover plate
- 7 Heater hole cover plate
- 8 Nutserts
- 9 Dash panel
- 10 Tie bolts, dash to chassis

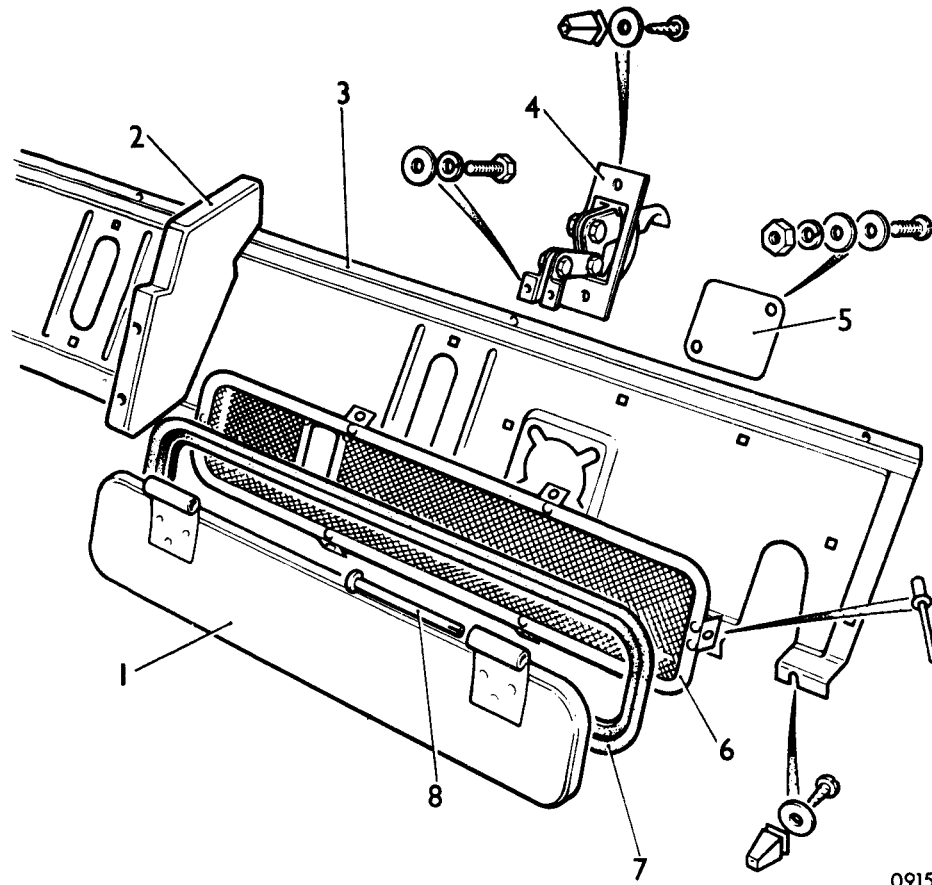

0915

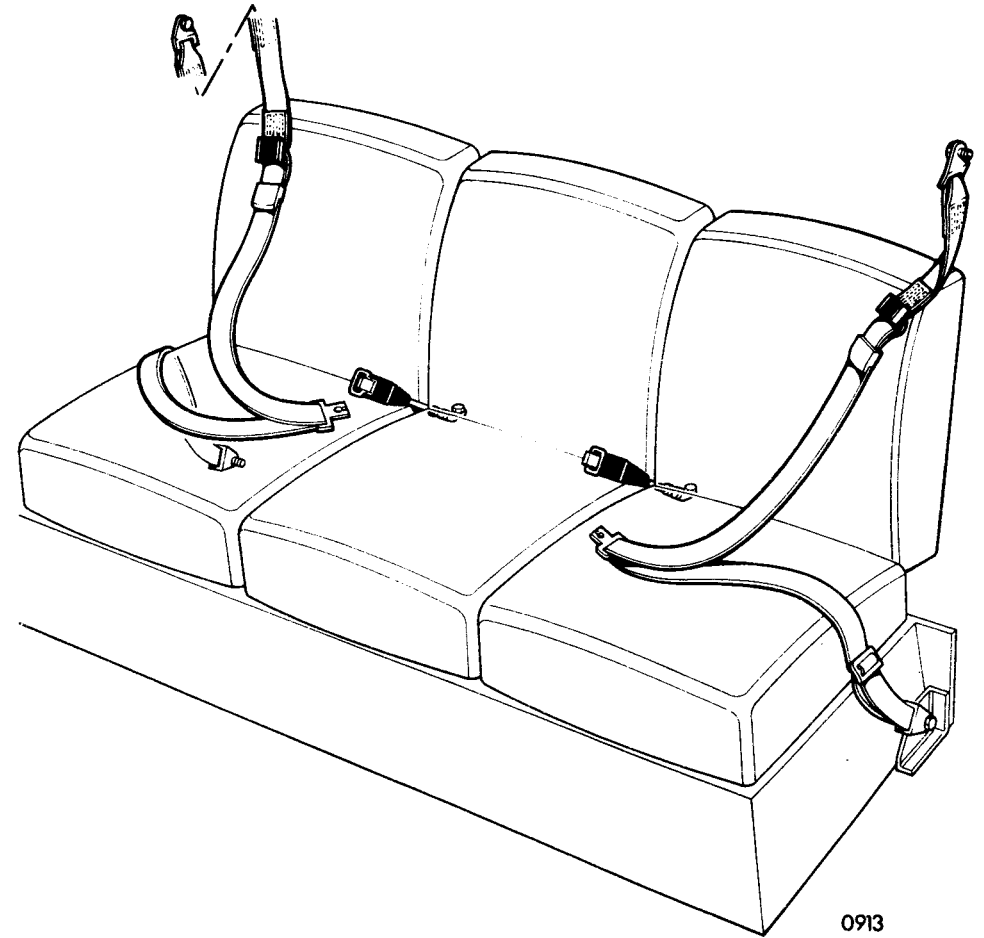

0913

**Ventilator and flyscreen
Key**

- 1 Dash ventilator lid
- 2 Air flow divider panel
- 3 Fascia - support panel
- 4 Ventilator mechanism assembly
- 5 Blanking plate
- 6 Flyscreen
- 7 Sealing rubber
- 8 Hinge pin

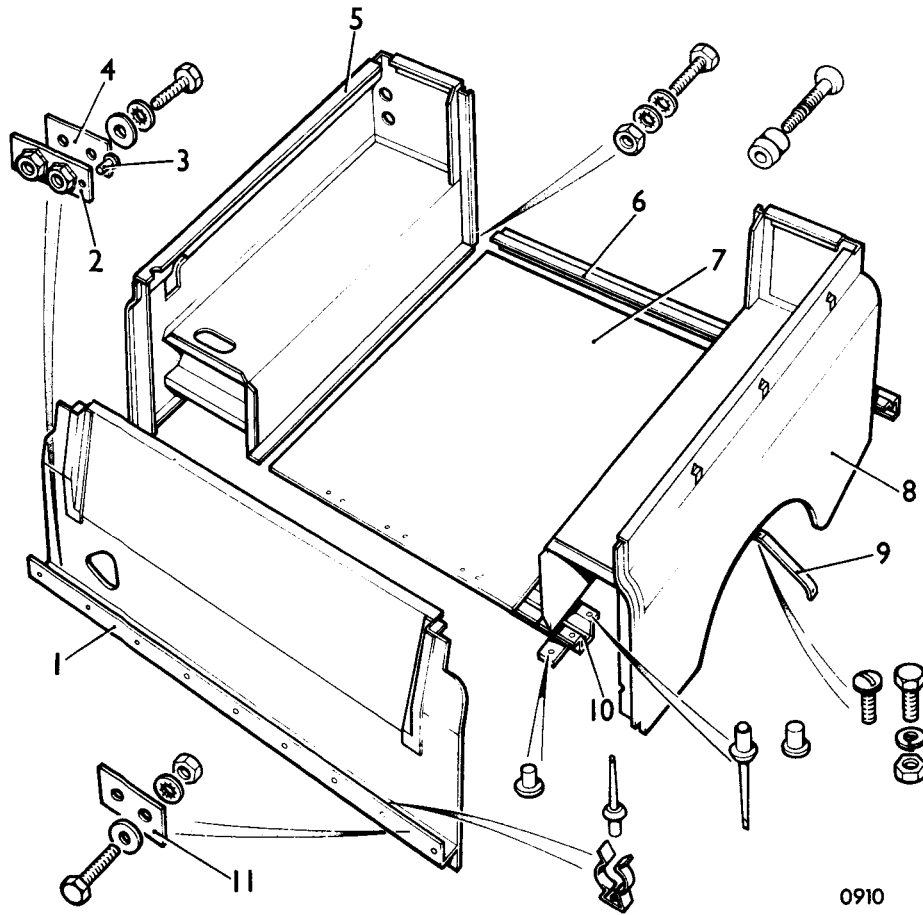

Rear body – 88

Key

- 1 Front end panel
- 2 Nut plate
- 3 Rivet
- 4 Shim
- 5 Body side – right hand
- 6 Rear mounting angle
- 7 Floor panel
- 8 Body side – left hand
- 9 Stay
- 10 Cross member
- 11 Shim

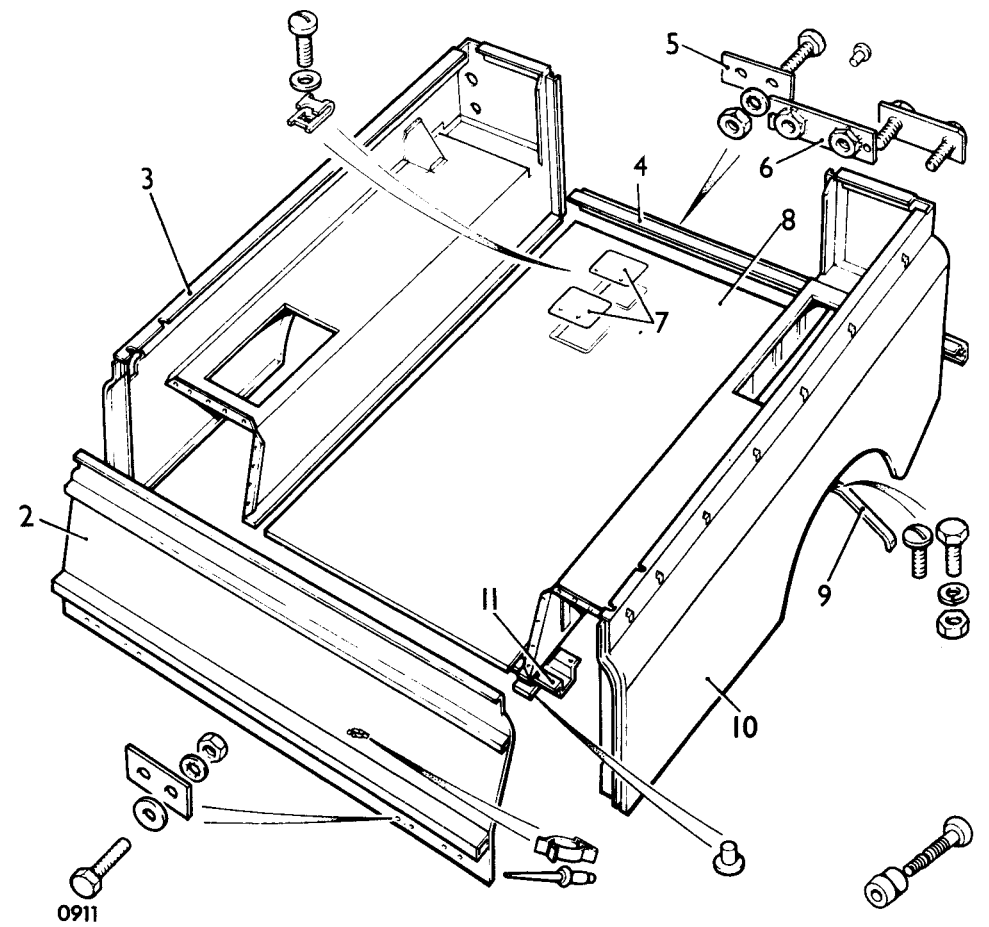

Rear body – 109 (Except station wagon)

Key

- 1 Shim
- 2 Front end panel
- 3 Body side, right hand
- 4 Rear mounting angle
- 5 Shim
- 6 Nut plate
- 7 Cover plates
- 8 Floor panel
- 9 Stay
- 10 Body side, left hand
- 11 Cross member

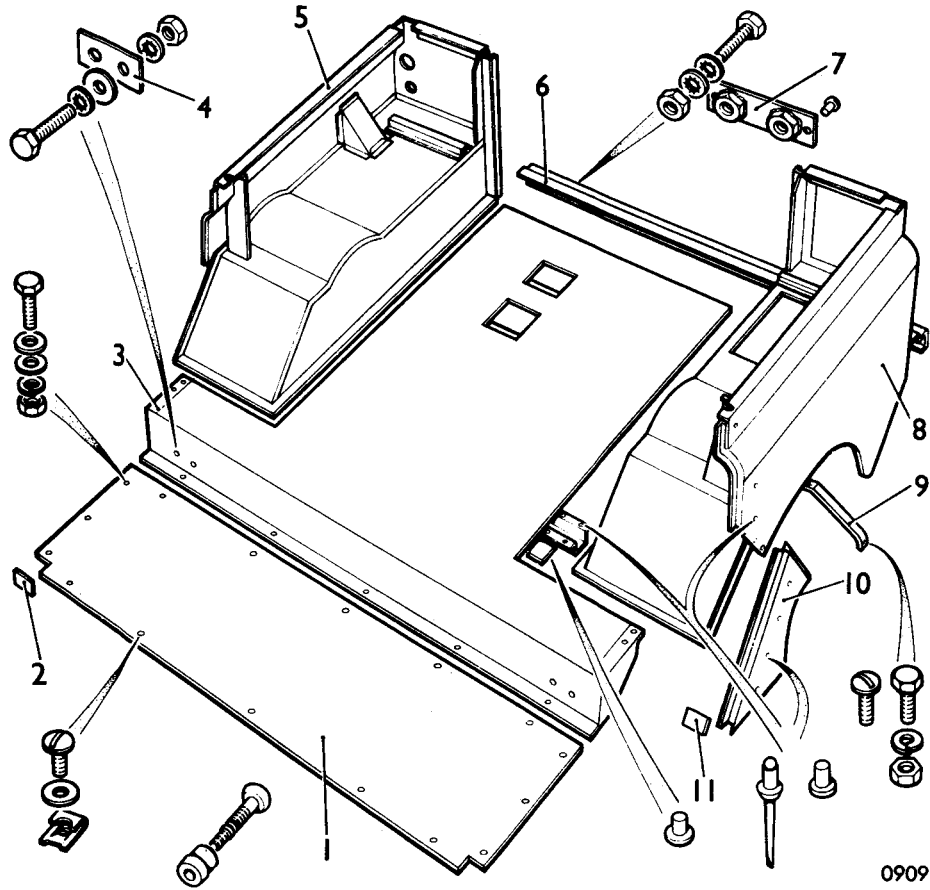

0909

**Body - 109 Station Wagon
Key**

- 1 Floor - intermediate
- 2 Sealing rubber
- 3 Floor - rear
- 4 Shim
- 5 Body side, right hand
- 6 Mounting angle
- 7 Nut plate
- 8 Body side, left hand
- 9 Stay
- 10 Front extension, left hand
- 11 Sealing rubber

**Front Door
Key**

- 1 Door seal
- 2 Door seal - side frame
- 3 Fixed glass
- 4 Packing strip
- 5 Glass channel - bottom
- 6 Retainer
- 7 Channel
- 8 Sealing rubber
- 9 Buffer
- 10 Channel
- 11 Filler
- 12 Sliding glass
- 13 Filler
- 14 Channel
- 15 Side screen frame
- 16 Sealing strip
- 17 Plug - window catch
- 18 Capping
- 19 Door seal
- 20 Door - front
- 21 Door seal

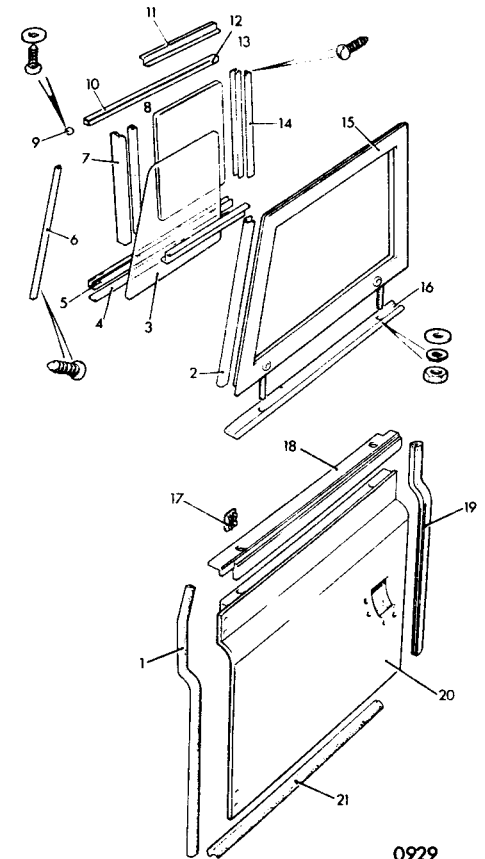

0929

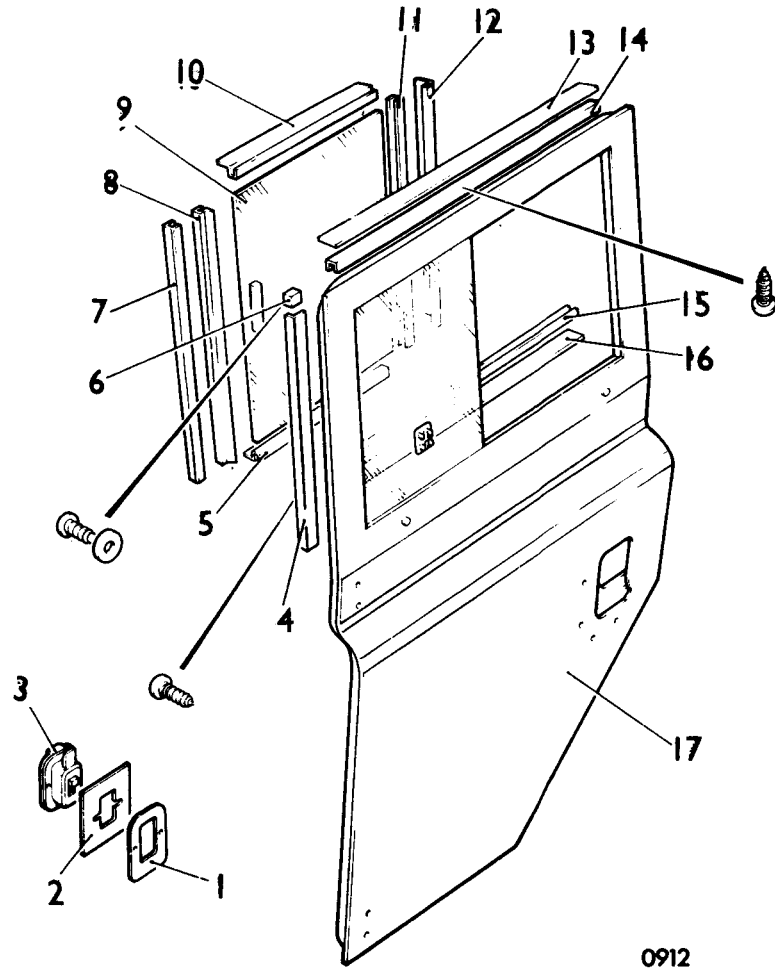

Door - rear - 109 station wagon
Key

- | | |
|------------------------|------------------|
| 1 Seal - window catch | 10 Retainer |
| 2 Mask - window catch | 11 Channel |
| 3 Window catch | 12 Filler |
| 4 Retainer | 13 Packing strip |
| 5 Filler | 14 Channel |
| 6 Buffer | 15 Channel |
| 7 Channel | 16 Packing strip |
| 8 Sealing rubber | 17 Rear door |
| 9 Door glass - sliding | |

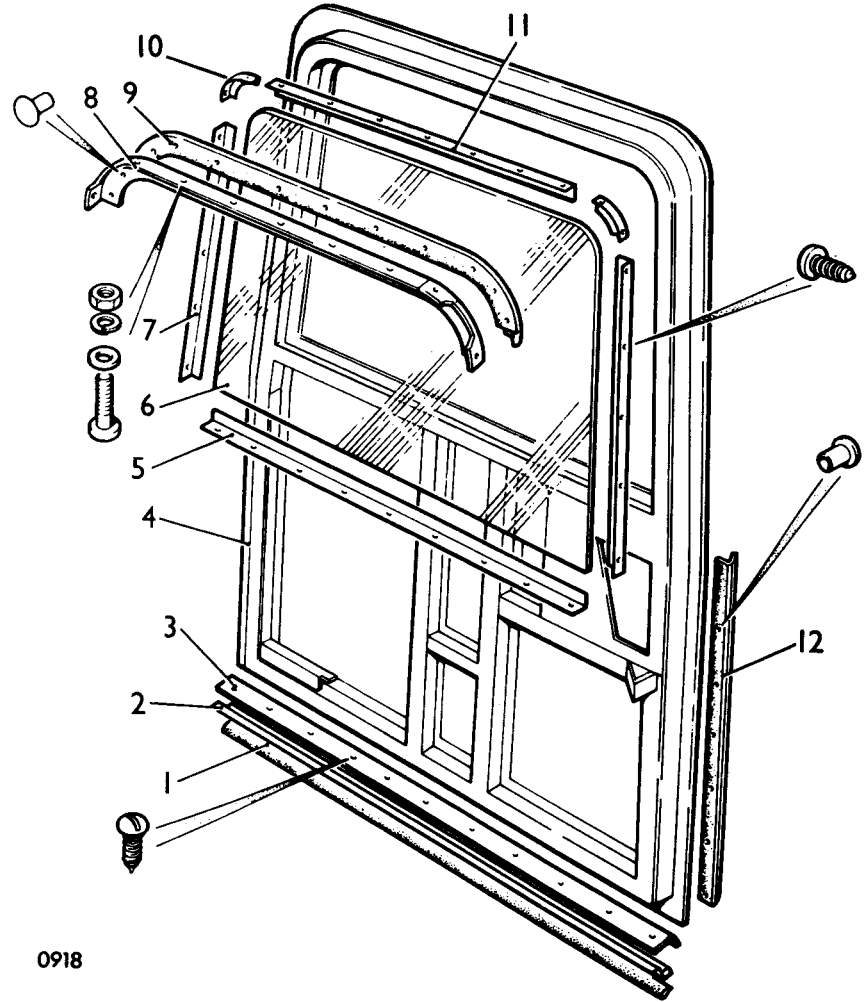

Tail door - station wagon
Key

- | | |
|---------------------------------|----------------------------------|
| 1 Seal | 7 Glass retainer strip - side |
| 2 Seal retainer | 8 Arch-hard top |
| 3 Protection strip | 9 Sealing rubber |
| 4 Rear door | 10 Glass retainer - corner piece |
| 5 Glass retainer strip - bottom | 11 Glass retainer strip - top |
| 6 Glass | 12 Seal |

**Cab and tropical roof
Key**

- 1 Cab roof
- 2 Sealing rubber, door top
- 3 Retainer for seal
- 4 Cab rear panel assembly
- 5 Rubber seal, roof to back panel, top
- 6 Rubber seal back panel to rear body
- 7 Sliding back light
- 8 Sealing rubber for back light
- 9 Channel for rubber
- 10 Channel, top and bottom } For back light
- 11 Channel, sides }
- 12 Back light catch
- 13-16 Fixing for catches
- 17 Runner for sliding back light catch
- 18 Cab quarter light, RH
- 19 Cab quarter light, LH
- 20 Weather strip } For quarter light
- 21 Sealing strip }
- 22 Sealing rubber, windscreen to roof
- 23 Sealing rubber, door side
- 24 Mounting stud
- 25 Mounting rail for cab
- 26 Mounting rail support bracket
- 27 Cab mounting distance piece
- 28 Cab tropical roof panel
- 29 Distance piece } Fixing tropical roof
- 30 Rubber }

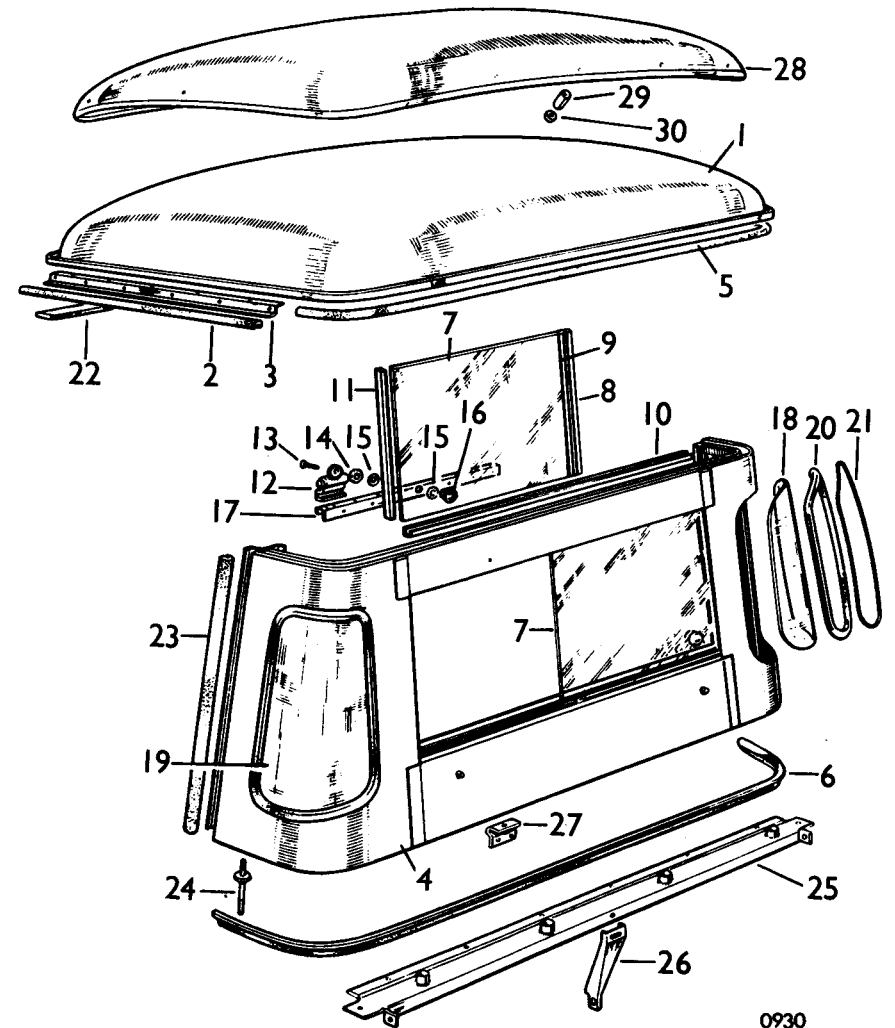

0930

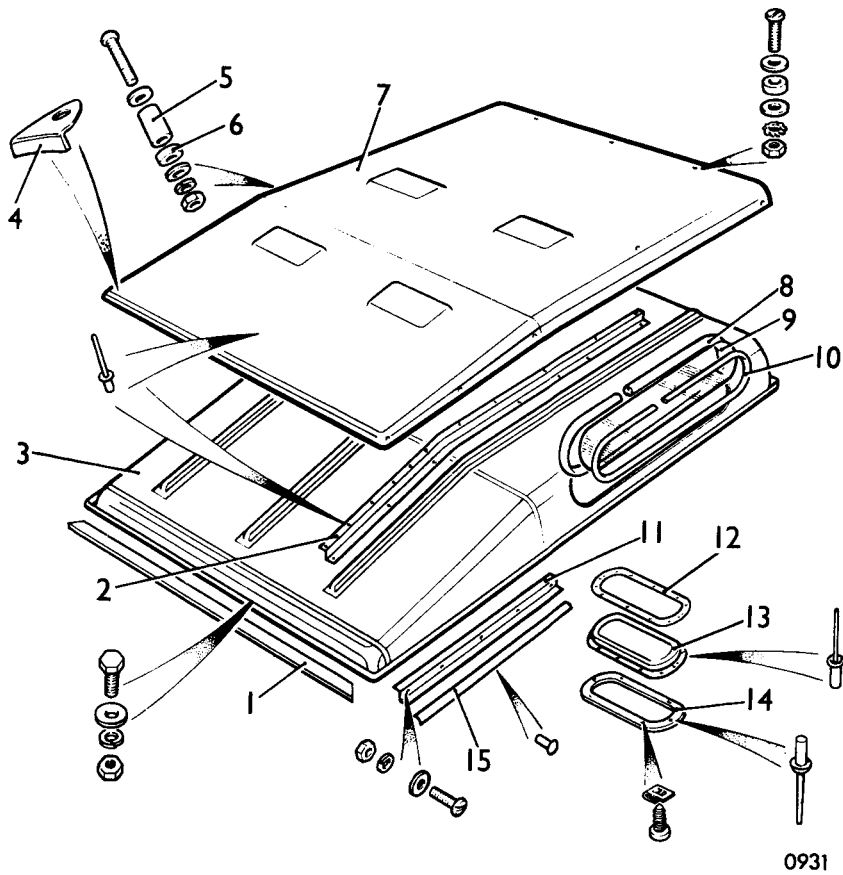

**Body, roof – 88 station wagon
Key**

- | | |
|-------------------|-------------------|
| 1 Sealing strip | 9 Roof glass |
| 2 Stiffener strip | 10 Filler strip |
| 3 Roof | 11 Seal retainer |
| 4 Corner capping | 12 Rubber seal |
| 5 Spacer | 13 Ventilator |
| 6 Rubber washer | 14 Retainer plate |
| 7 Tropical roof | 15 Seal |
| 8 Weather strip | |

0931

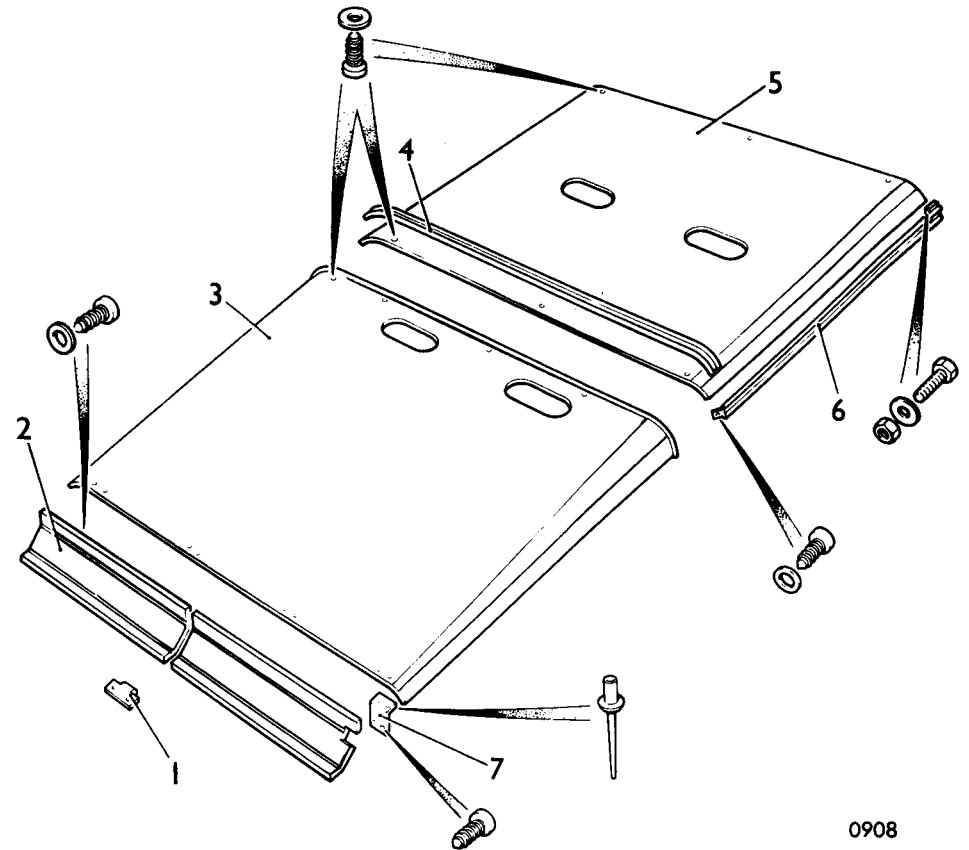

**Roof trim – 88 station wagon
Key**

- | |
|----------------|
| 1 Bracket |
| 2 Trim panel |
| 3 Roof trim |
| 4 Centre strip |
| 5 Head cloth |
| 6 Side rail |
| 7 Bracket |

0908

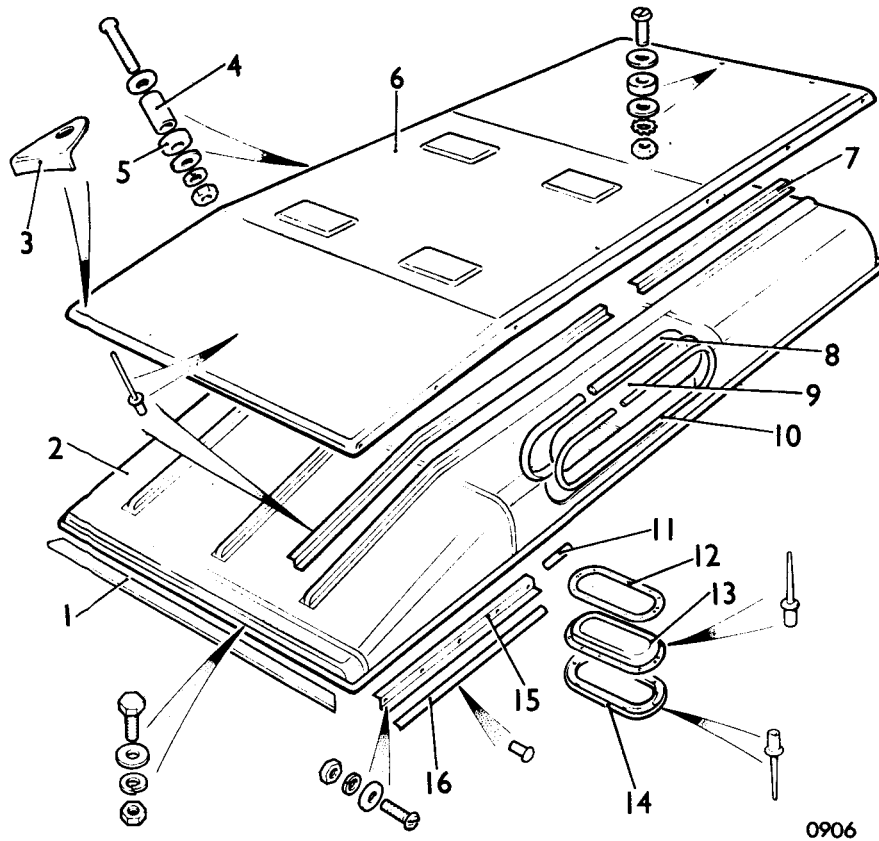

Body roof — 109 station wagon
Key

- | | |
|------------------|-------------------|
| 1 Sealing strip | 9 Roof glass |
| 2 Roof | 10 Filler strip |
| 3 Corner capping | 11 Sealing rubber |
| 4 Spacer | 12 Rubber seal |
| 5 Rubber washer | 13 Ventilator |
| 6 Tropical roof | 14 Retainer plate |
| 7 Stiffener | 15 Seal retainer |
| 8 Weather strip | 16 Rubber seal |

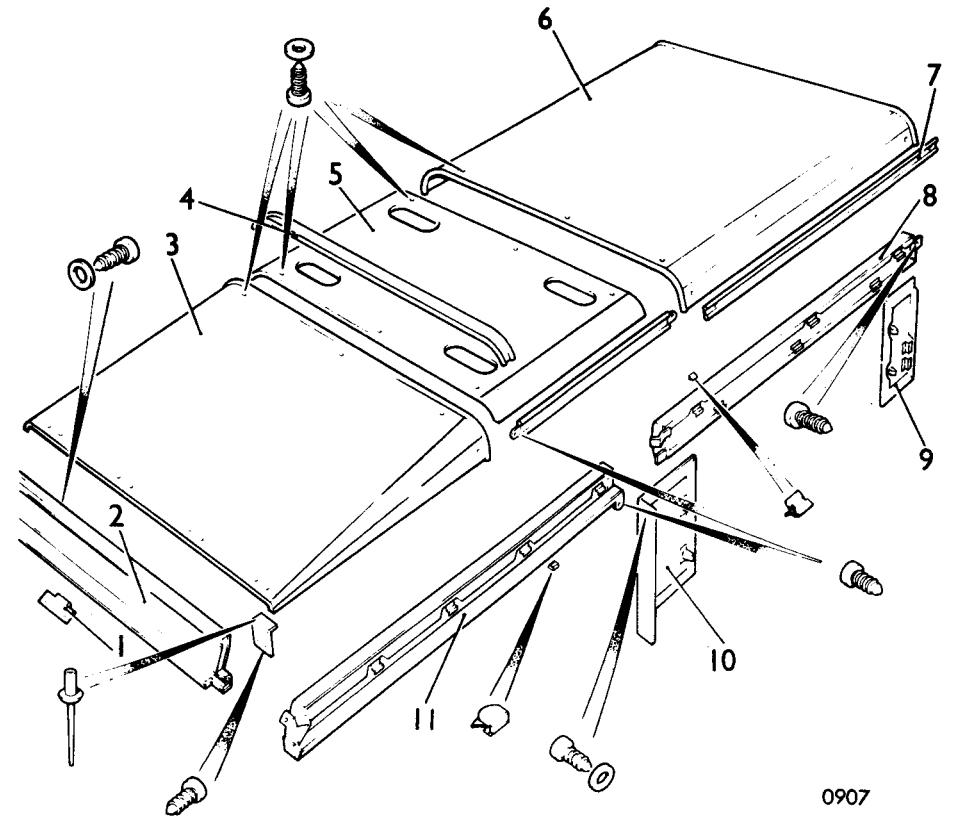

Roof trim — 109 station wagon
Key

- | |
|--------------------|
| 1 Bracket |
| 2 Trim panel |
| 3 Roof trim |
| 4 Centre strip |
| 5 Headcloth |
| 6 Headcloth |
| 7 Strip |
| 8 Cant rail — rear |
| 9 Casing |
| 10 Side rail |
| 11 Casing |

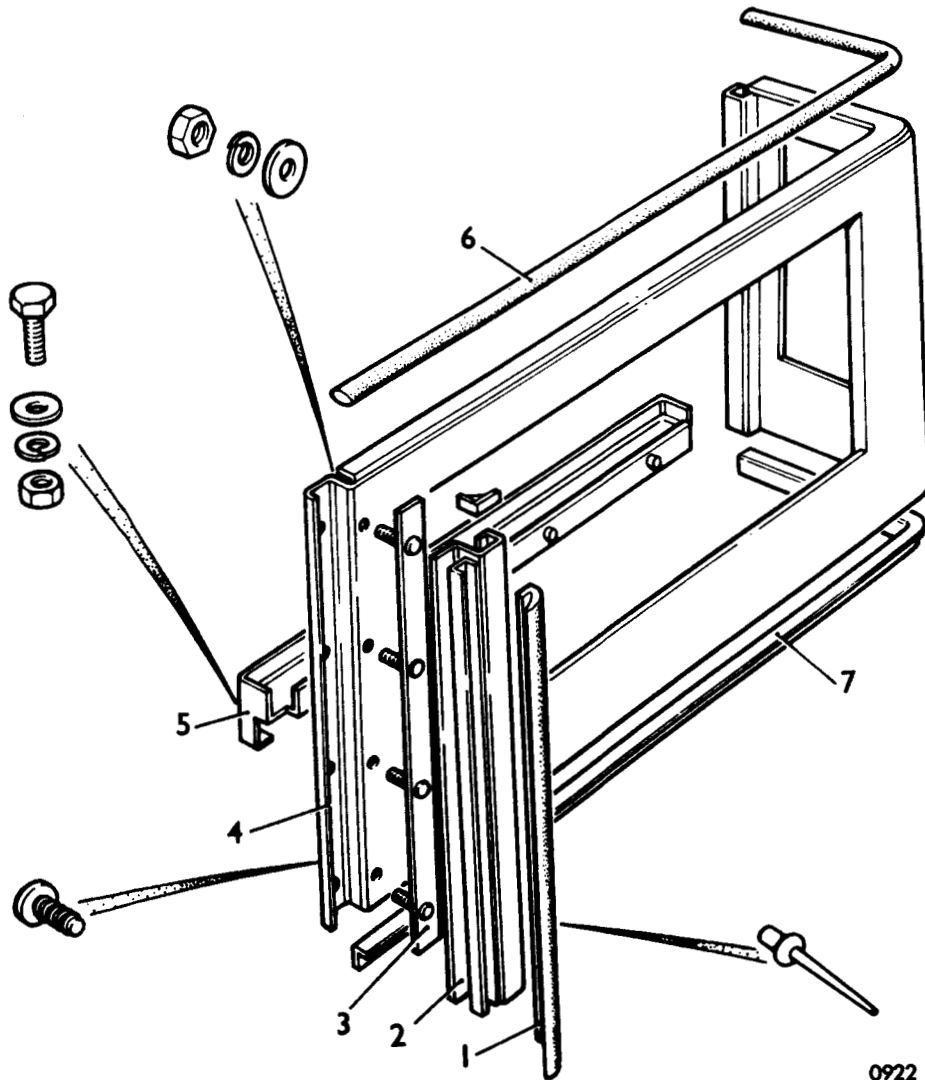

Side panel and fixings – station wagon
Key

- | | |
|--------------|------------------|
| 1 Seal | 5 Drain channel |
| 2 Capping | 6 Sealing rubber |
| 3 Stud plate | 7 Sealing rubber |
| 4 Side panel | |

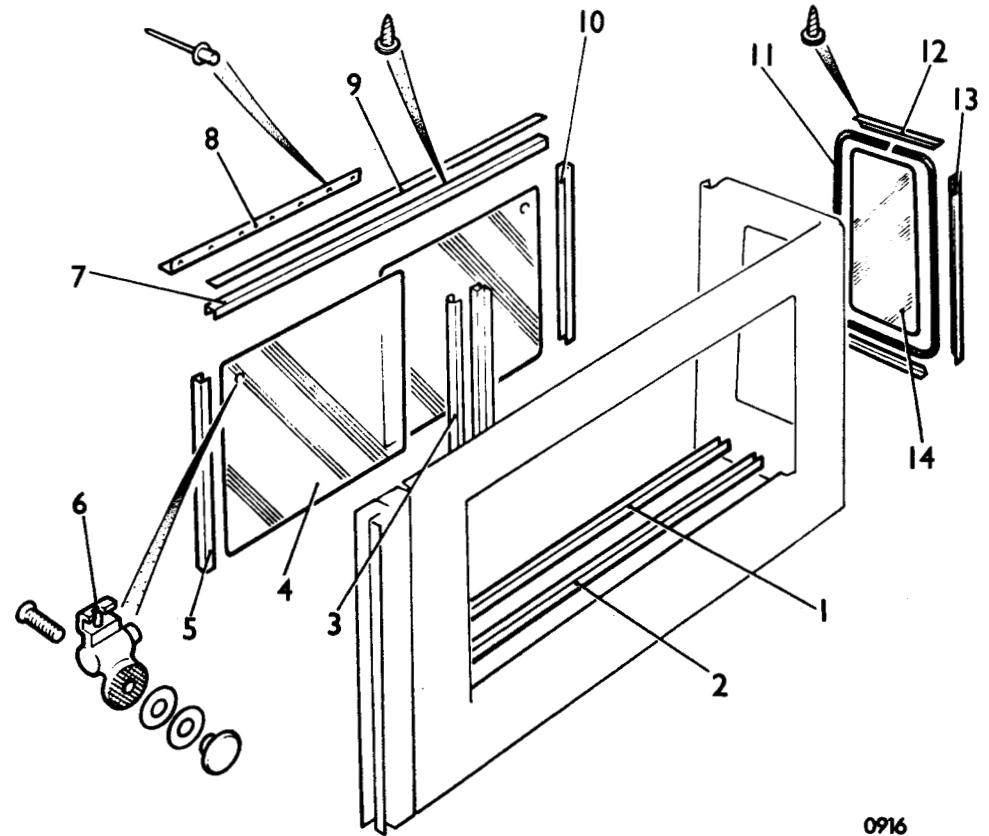

Rear windows – station wagon
Key

- | | |
|-----------|-------------------|
| 1 Channel | 8 Runner |
| 2 Channel | 9 Packing strip |
| 3 Channel | 10 Channel |
| 4 Glass | 11 Glazing strip |
| 5 Channel | 12 Retainer strip |
| 6 Catch | 13 Retainer strip |
| 7 Channel | 14 Glass |

CHASSIS FRAME

Alignment check

76.10.02

Procedure

With the vehicle assembled a check for chassis 'squareness' can be made as follows. Instructions 1 to 7.

- 1 Place the vehicle on a level floor.
- 2 Hold a plumb line against one of the measuring points as illustrated. (The measuring points are the fixed spring shackle locations.)
- 3 Mark the floor directly beneath the plumb-bob.
- 4 Repeat items 2 and 3 at the remaining measuring points.

NOTE: When measuring diagonals, ensure that exactly corresponding points are used on each side of the chassis frame.

- 5 Move the vehicle and measure between the chalk marks.
- 6 The diagonals between the related measuring points should agree within 9,5 mm (0.375 in.).
- 7 Using a suitable trammel, make comparative side-to-side checks between the front suspension front shackle pin and the rear wheel hub centre.
- 8 With the vehicle upper structure removed, comparative side-to-side checks for chassis frame misalignment can be made, using as datums the 9,5 mm (0.375 in.) diameter holes provided in the No. 2 and also in the rearmost cross-member.

NOTE: The vehicle front bumper is regarded as the No. 1 cross-member.

- 9 Chassis frame dimensional checks can be made referring to the applicable illustration and associated key.

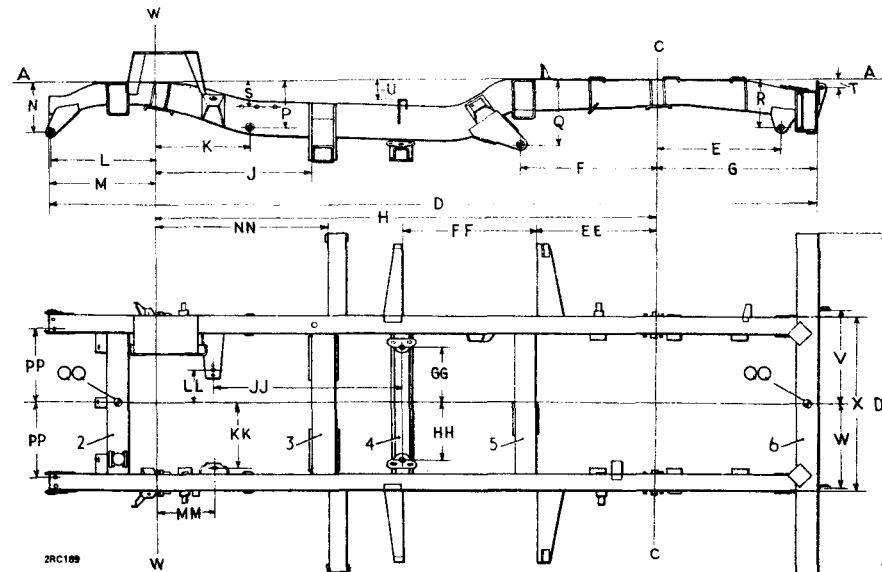
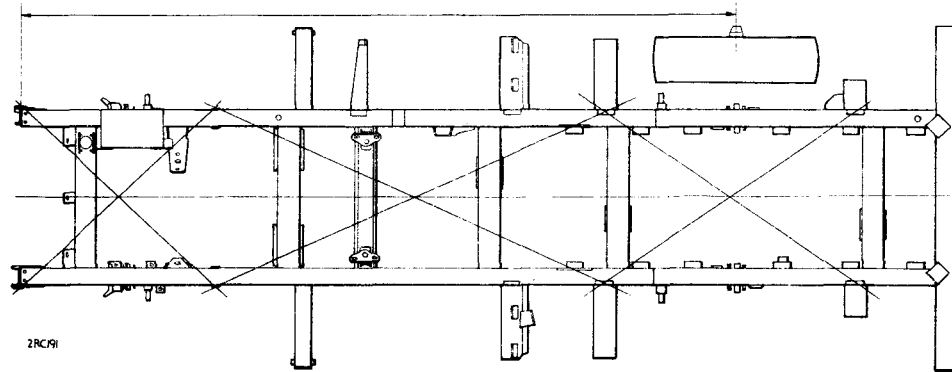

Chassis frame dimensions, 88 models

AA	- Datum line
WW	- Centre line of front axle
CC	- Centre line of rear axle
D	- 3420 mm (134.6 in.)
E	- 539,7 mm (21.25 in.)
F	- 610 mm (24.0 in.)
G	- 713,2 mm (28.08 in.)
H	- 2235 mm (88.0 in.)
J	- 793,7 mm (31.25 in.)
K	- 422,3 mm (16.625 in.)
L	- 457 mm (18.0 in.)
M	- 472,2 mm (18.58 in.)
N	- 229 mm (9.0 in.)
P	- 212,7 mm (8.37 in.)
Q	- 290,5 mm (11.44 in.)
R	- 198,4 mm (7.81 in.)
S	- 120,6 mm (4.75 in.)
T	- 29,3 mm (1.15 in.)
U	- 82,5 mm (3.25 in.)
V	- 432 mm (17.0 in.)
W	- 387,3 mm (15.25 in.)
X	- 787 mm (31.0 in.)
DD	- 1536 mm (60.5 in.)
EE	- 539,7 mm (21.25 in.)
FF	- 610 mm (24.0 in.)
GG	- 257 ± 0,8 mm (10.12 ± 0.030 in.)
HH	- 254 ± 0,8 mm (10.00 ± 0.030 in.)
JJ	- 835 ± 0,8 mm (32.87 ± 0.030 in.)
KK	- 289,7 mm (11.40 in.)
LL	- 166,7 mm (6.56 in.)
MM	- 250,8 ± 1,5 mm (9.875 ± 0.060 in.)
NN	- 768,3 mm (30.25 in.)
PP	- 331,78 ± 0,5 mm (13.062 ± 0.020 in.)
QQ	- 9,52 mm (0.375 in.) diameter holes

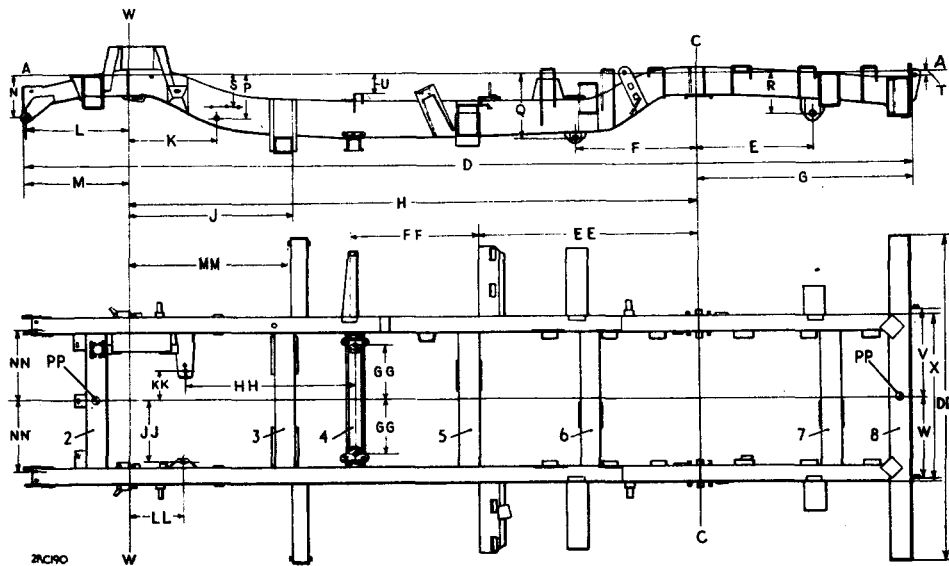

Chassis frame dimensions, 109 models

AA	- Datum line	U	- 82,5 mm (3.25 in.)
WW	- Centre line of front axle	V	- 432 mm (17.0 in.)
CC	- Centre line of rear axle	W	- 387,3 mm (15.25 in.)
D	- 4240 mm (166.9 in.)	X	- 787 mm (31.0 in.)
E	- 539,7 mm (21.25 in.)	DD	- 1536 mm (60.5 in.)
F	- 610 mm (24.0 in.)	EE	- 1070 mm (42.12 in.)
G	- 1000 mm (39.375 in.)	FF	- 641 mm (25.2 in.)
H	- 2770 mm (109 in.)	GG	- 257 ± 0,8 mm (10.125 ± 0.030 in.) 2.6 & 2½ litre
J	- 793,7 mm (31.25 in.)	HH	- 835 ± 0,8 mm (32,87 ± 0.030 in.) 2½ litre
K	- 422,3 mm (16.625 in.)		- 984 ± 0,8 mm (38.74 ± 0.030 in.) 2.6 litre
L	- 457 mm (18.0 in.)	JJ	- 289,71 mm (11.406 in.) 2½ litre
M	- 472,2 mm (18.58 in.)		- 290,51 mm (11.437 in.) 2.6 litre
N	- 229 mm (9.0 in.)	KK	- 166,7 mm (6.56 in.)
P	- 212,7 mm (8.37 in.)	LL	- 250,7 mm (9.87 in.) 2½ litre
Q	- 296,8 mm (11.68 in.)		- 193,7 mm (7.62 in.) 2.6 litre
R	- 204,7 mm (8.06 in.)	MM	- 763 mm (30 in.) 2½ & 2.6 litre
S	- 120,6 mm (4.75 in.)	NN	- 331,8 ± 0,5 mm (13.06 ± 0.062 in.)
T	- 29,3 mm (1.15 in.)	PP	- 9,52 mm (0.375 in.) diameter holes

FRONT FLOOR

Remove and refit **76.10.12**
 2½ litre models, instructions 1 to 7 and 11 to 13
 2.6 litre models, instructions 1 to 4 and 8 to 13

Removing

- 1 Unscrew the knob and locknut from the transfer gear lever.
- 2 Remove the fixings and withdraw the dust cover from the transfer gear lever.
- 3 Unscrew the knob and locknut from the four-wheel drive lever.
- 4 Withdraw the spring and ferrule.

2½ litre models

- 5 Remove both halves of the front floor.
- 6 Remove the gearbox tunnel cover.
- 7 Remove a gearbox tunnel front panel.

2.6 litre models

- 8 Remove the gearbox tunnel cover.
- 9 Remove the gearbox tunnel front panel.
- 10 Remove both halves of the front floor.

Refitting, both models

- 11 Reverse instructions 8 to 10 or 5 to 7 as applicable.
Use waterproof sealant between the joint flanges.
- 12 Adjust the four-wheel drive lever during assembly, as follows: Fit the ferrule, spring and locknut to the lever, depress the lever and adjust the locknut until the compressed spring length is 58 mm (2.312 in.), then fit the knob and tighten the locknut.
- 13 Reverse instructions 1 and 2.

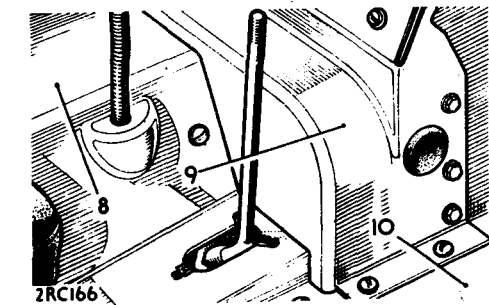
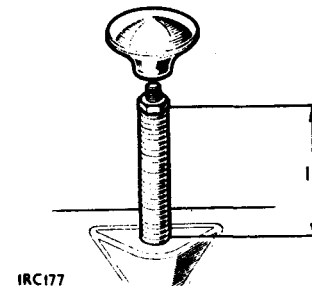
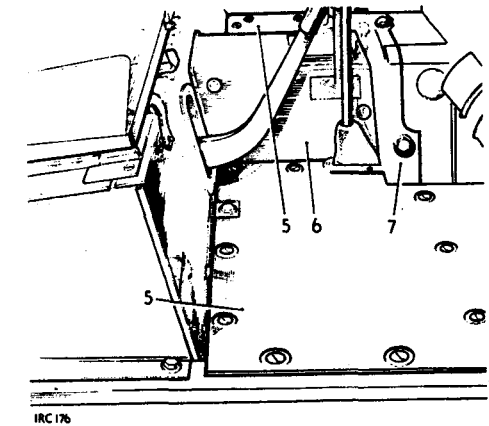
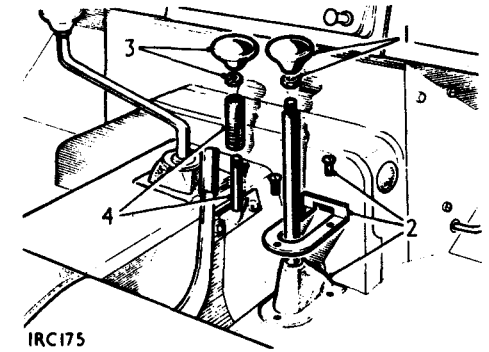

FRONT WING

Remove and refit

76.10.26

Removing

- 1 Disconnect the battery.
- 2 Jack up the vehicle and support securely.
- 3 Remove the front wheel.
- 4 Remove the radiator grille.
- 5 Disconnect the headlamp leads at the snap connectors.
- 6 Disconnect the side lamp and flasher lamp at the snap connectors.
- 7 Remove the bolts securing the wing to the radiator grille panel.
- 8 Remove the bolts securing the wing stay.
- 9 Remove the bolts securing the wing to the sill.
- 10 Remove the bolts securing the wing to the cover plate.
- 11 Remove the bolts securing the mudshield.
- 12 Remove the bolts securing the wing to the scuttle and scuttle pillar.
- 13 Withdraw the front wing.
- 14 Remove the headlamp, side lamp and flasher lamp if required.
- 15 The foregoing instructions outline the basic wing attachment details. Depending upon whether the wing to be removed is left or right hand, the vehicle is fitted with left or right hand steering, is fitted with a heater, or is a servo brake diesel model, the following additional operations may be necessary.

Bonnet removal.

Windscreen washer reservoir.

Vacuum tank - servo brake, diesel only.

Heater fan motor and connections.

Heater air intake connections.

Steering drop arm cover box.

Wiring harness attachment to wing valance.

Windscreen washer hose attachment to wing valance.

Windscreen washer pump.

Refitting

- 16 Reverse instructions 1 to 15.

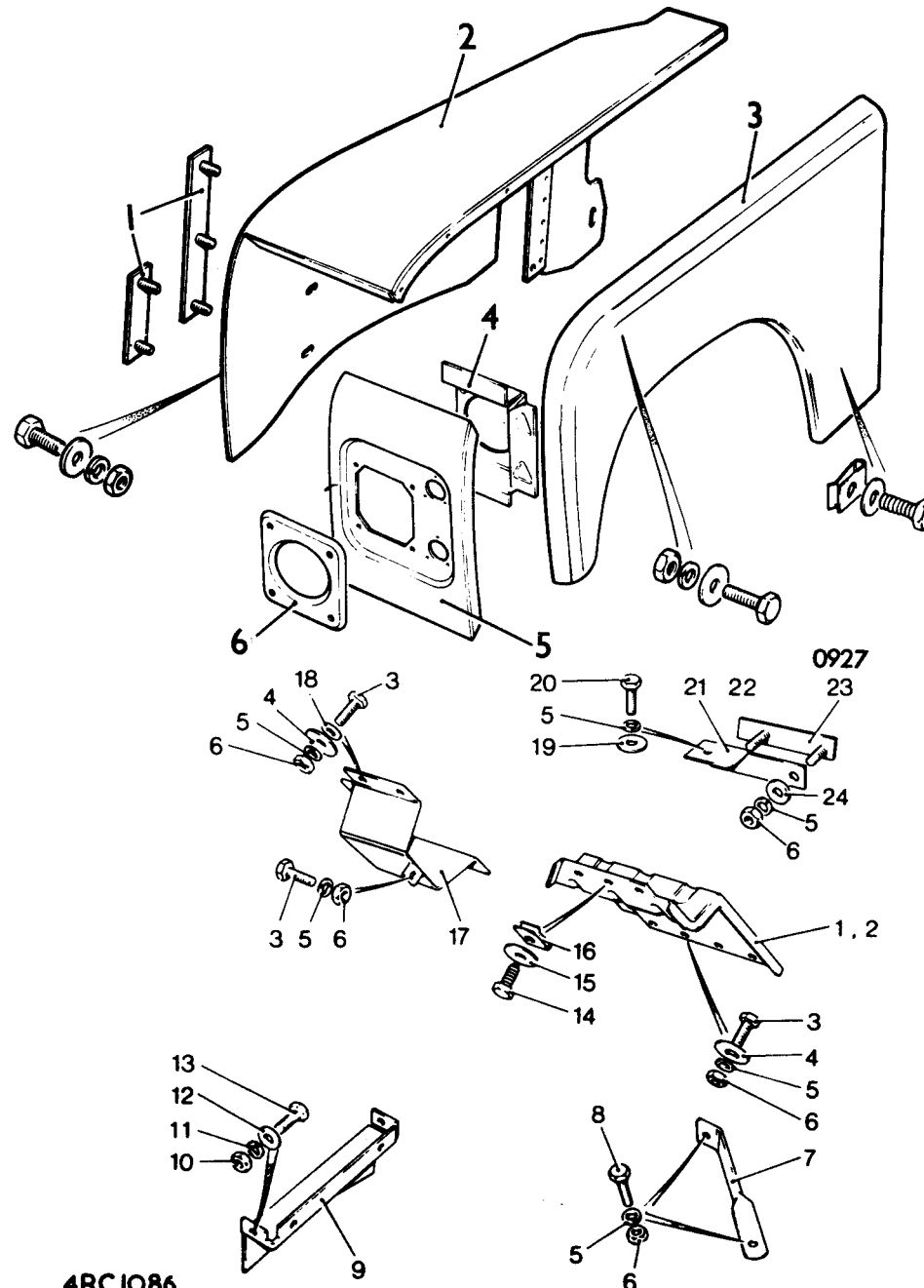

Front wing

Key

- 1 Fixing plates
- 2 Wing - rear valance assembly
- 3 Wing - outer panel
- 4 Headlamp mounting panel
- 5 Front panel
- 6 Headlamp surround

Cover panels - front wing

Key

- 1 Bottom panel - front wing valance
- 2 Cover plate (2¼ Petrol only)
- 3 Cover box - steering drop arm
- 4 Bracket
- 5 Nut plate
- 6 Mudshield
- 7 Wing stay

4RC1086

SIDE DOOR GLASS

Front door 76.31.01
Rear door 76.31.02

Remove and refit

Removing

Sliding glass

- 1 Remove the screw and rubber stop from the front end of the sliding glass top channel. Remove the remaining channel securing screws.
- 2 Incline the sliding glass inwards complete with top channel and the filler strip.
- 3 Remove the channel and filler strip.
- 4 Lift out the sliding glass.

Fixed glass

- 5 Remove the sliding glass (instructions 1 to 4 above).
- 6 Remove the front angle strip.
- 7 Carefully release the fixed glass from the sealing compound.
- 8 Withdraw the fixed glass.
- 9 Remove the old sealing compound from glass and door.

Refitting

Fixed glass

- 10 Apply fresh sealing compound to the door frame.
- 11 Carefully insert the fixed glass and press firmly into position. Remove surplus sealing compound.
- 12 Fit the front angle sealing strip.

Sliding glass

- 13 Fit the sliding glass, top channel and filler strip in reverse order to instructions 1 to 4.

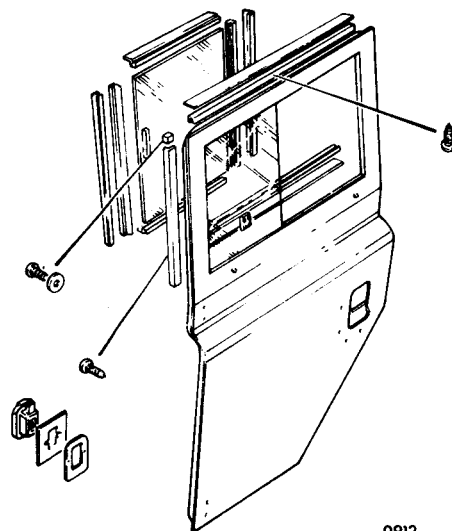

0912

DOOR LOCK

Remove and refit

Side door, front 76.37.12
Side door, rear 76.37.13
Tail door 76.37.16

Removing

- 1 Remove the door trim where fitted.
- 2 Remove the screws securing the lock to the door edge (not anti-burst type).
- 3 Remove the two screws securing the top of the lock to the door.
- 4 Remove the tapped plate.
- 5 Remove the nuts securing the bottom of the lock to the door.
- 6 Remove the studplate.
- 7 Remove the door lock and sealing plate. (Sealing plates are not fitted to anti-burst type locks.)

Refitting

- 8 Reverse instructions 1 to 7.

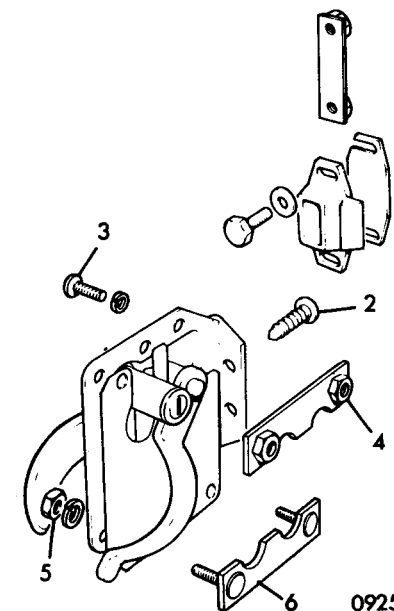

0925

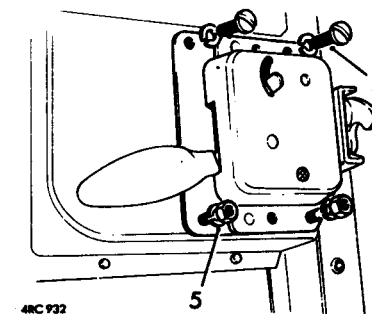

48C 932

FASCIA TOP RAIL**Remove and refit****76.46.04****Removing**

- 1 Remove the screws securing the fascia top rail end cover and heater control. Ease the end cover aside.
- 2 Remove the screws securing the fascia top rail end cover (passenger's side). Withdraw the end cover.

- 3 Remove the two nuts and bolts securing the rear of the fascia top rail to the fascia mounting plate.
- 4 Remove the screws securing the demist outlets. Withdraw the demist outlets.
- 5 Remove the screws securing the front of the fascia top rail.
- 6 Remove the top rail.

Refitting

- 7 Reverse instructions 1 to 6.

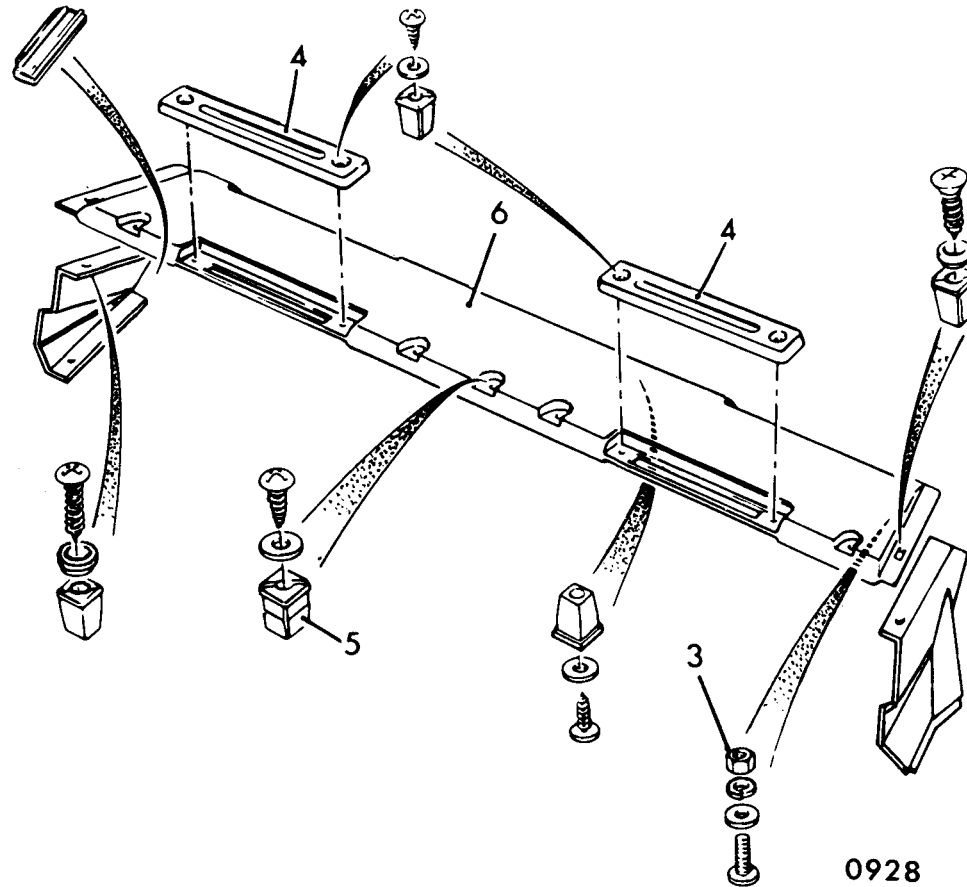
**LOWER FASCIA****Remove and refit****76.46.05****Removing**

- 1 Release the shroud from the steering column and the lower fascia.
- 2 Remove the heater control panel from the driver's end of the fascia and disconnect the distribution control cable.
- 3 Withdraw the instrument panel clear of the dash.
- 4 Withdraw the demister hoses.
- 5 Withdraw the finisher strip from the top edge of the lower fascia.

- 6 If the vehicle is fitted with auxiliary instruments at the centre of the lower fascia, remove as applicable.
- 7 Remove the end cover from the lower fascia.
- 8 Remove the parcel tray.
- 9 Remove the fixings securing the lower fascia to the dash.
- 10 Withdraw the lower fascia.
- 11 If required, remove the heater duct cover and the distribution flap valves, as applicable.

Refitting

- 12 Reverse instructions 1 to 11. Where applicable, ensure that the gasket is fitted between the heater duct and the dash.

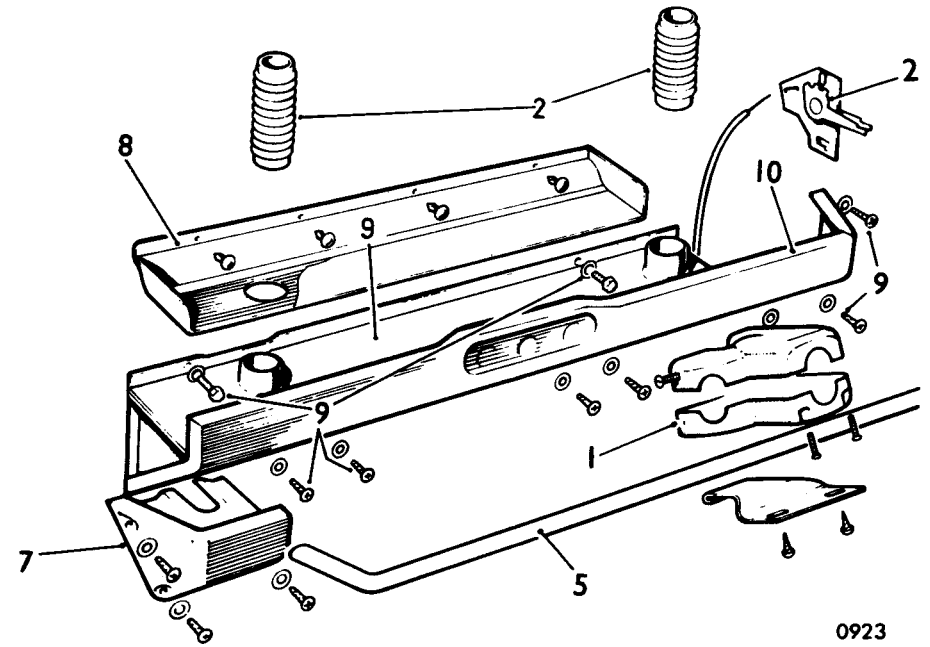

FASCIA SUPPORT PANEL

Remove and refit 76.46.06

Removing

- 1 Disconnect the battery.
- 2 Remove the fascia top rail. 76.46.04.
- 3 Remove the instrument panel.
- 4 Disconnect the heater hoses from the demister nozzles.
- 5 Remove the instrument housing.
- 6 Remove the fixings securing the ventilator control levers to the lids.
- 7 Remove the ventilator controls complete.
- 8 If the vehicle is fitted with an auxiliary instrument panel, remove the fixings securing it to the fascia support panel.
- 9 Remove the fixings securing the fascia support panel to the dash.
- 10 Withdraw the fascia support panel.
- 11 Remove the heater demister nozzles.

Refitting

- 12 Reverse instructions 1 to 11.

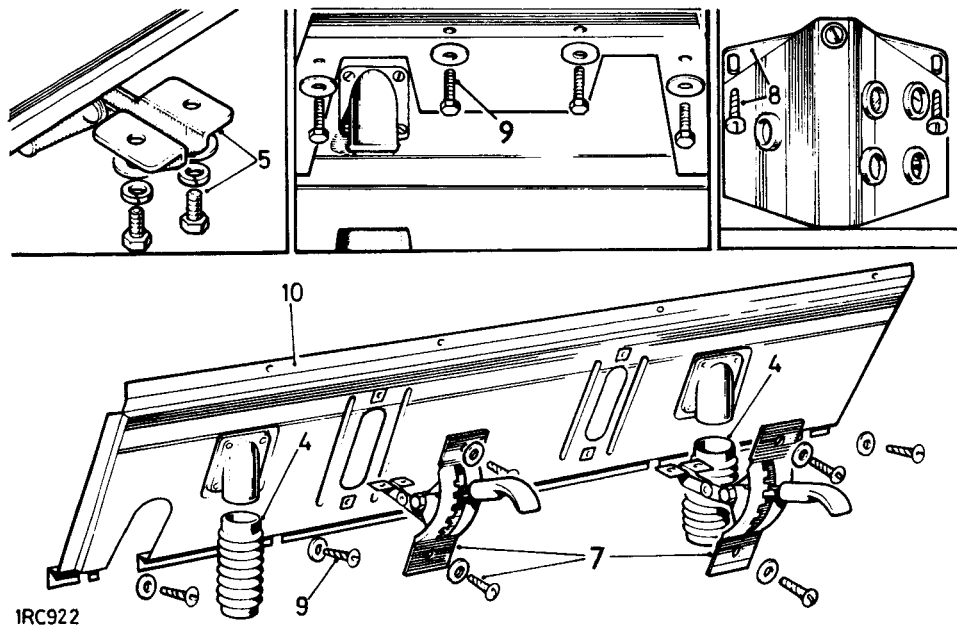

FRONT SEAT BASE

Remove and refit 76.70.06

Removing

- 1 Remove the driver's floor panel.
- 2 Remove the passenger's floor panel.
- 3 Remove the gearbox cover panel.
- 4 Remove all seat cushions.
- 5 Release the safety bolts from their anchor brackets at the seat base.
- 6 Remove the safety belt anchor brackets.

- 7 Remove the bolts securing the seat base.
- 8 Release the passenger's door check stay.
- 9 Remove the handbrake draught excluder.
- 10 Manoeuvre the seat base clear of the handbrake lever.
- 11 Withdraw the seat base.

Refitting

- 12 Reverse instructions 1 to 11. Use a suitable waterproof sealant when fitting the seat base gearbox cover, and floor panels.

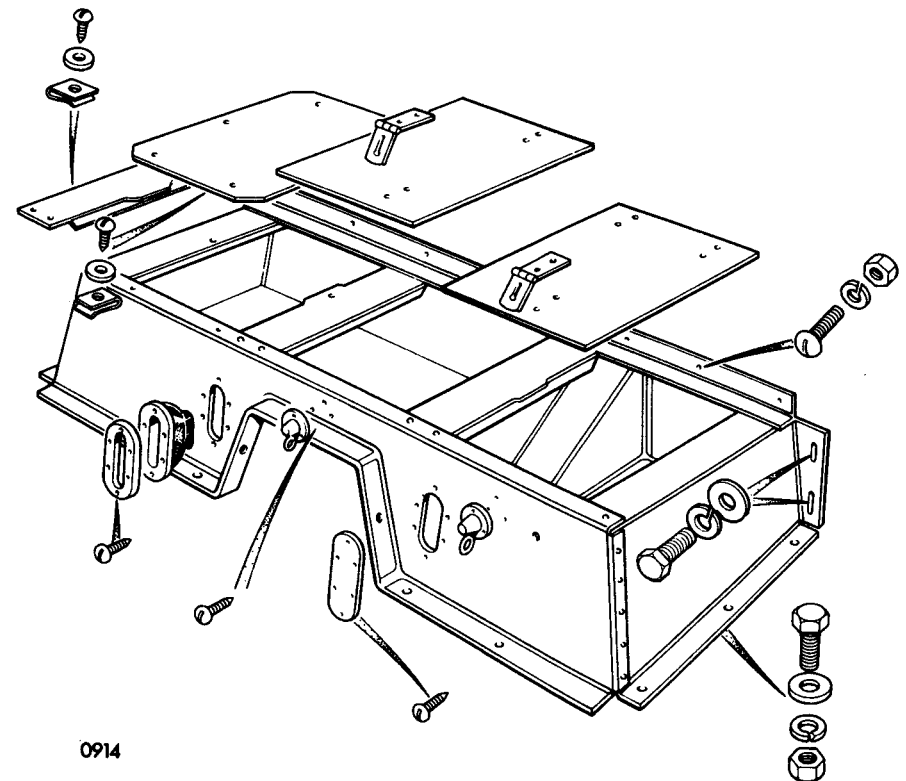

WINDSCREEN**Remove and refit****76.81.02****Removing****Soft top**

- 1 Remove the windscreen wiper arms and blades.
- 2 Release the straps securing the hood to the windscreen frame.
- 3 Detach the hood tape from windscreen hooks.
- 4 Roll back the hood clear of the windscreen.
- 5 Remove the bolts securing the door top channels to the windscreen.
- 6 Slacken the nuts on the windscreen clamp bolts. Swing the clamp bolts clear of the windscreen.
- 7 Disconnect the wiper motor earth lead from the windscreen frame.
- 8 Remove the bolts securing the windscreen to the hinges.
- 9 Remove the windscreen

Hard top

- 10 Remove the bolts securing the roof to the windscreen.
- 11 Slacken or remove the remaining roof fixings.
- 12 Carry out instructions 1 and 6 to 9.

Refitting**Soft top**

- 13 Reverse instructions 1 to 9. Ensure that the windscreen lower sealing strip is properly located and in good condition.

Hard top

- 14 Reverse instructions 1 and 6 to 11. Ensure that the windscreen top and bottom sealing strips are properly located and in good condition before tightening the roof fixings.

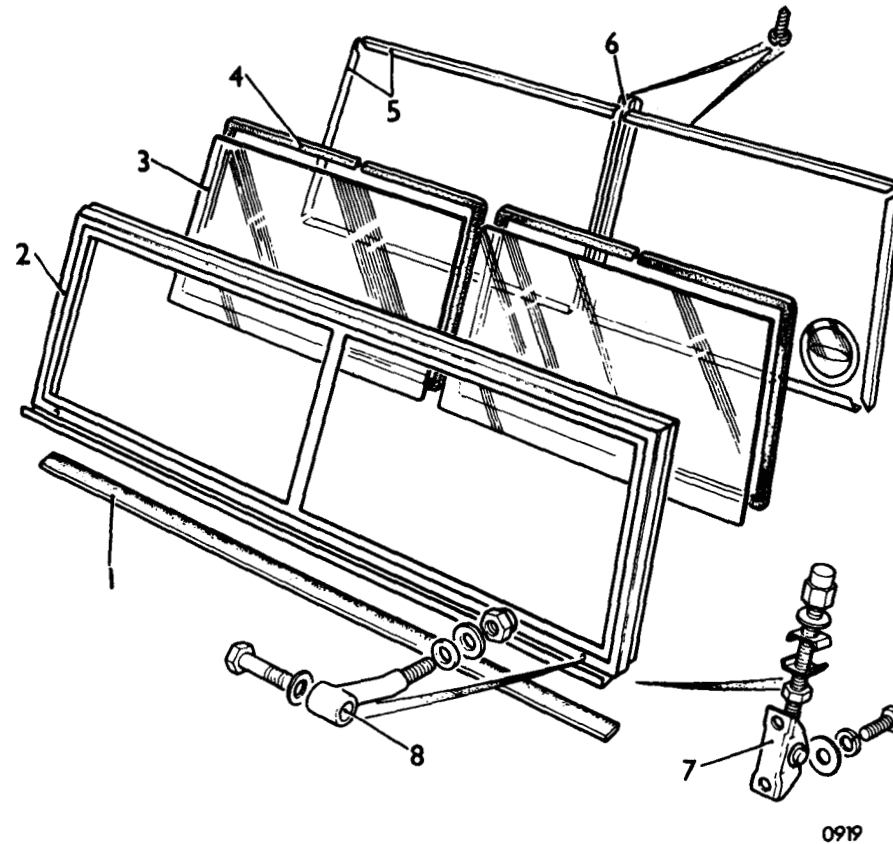

**Windscreen assembly
Key**

- | | |
|---|---------------------------|
| 1 | Seal |
| 2 | Windscreen frame |
| 3 | Windscreen glass |
| 4 | Glazing strip |
| 5 | Glass retaining strips |
| 6 | Centre cover strip |
| 7 | Windscreen clamp assembly |
| 8 | Windscreen hinge arm |

WINDSCREEN GLASS

Remove and refit

76.81.03

Removing

- 1 Remove the windscreen wiper arms and blades.

Soft top

- 2 Remove the windscreen frame assembly. 76.81.02.

Hard top

- 3 Remove the sun visors and rear view mirror from the interior of the cab.
- 4 Remove the headlining strip from above the windscreen.
- 5 Remove the fascia top rail. 76.46.04.

All models

- 6 Remove the screws securing the glass retaining angle strips.
- 7 Carefully ease the glass clear of the screen.
- 8 Remove all traces of sealant from the windscreen frame and glass retaining strips.

Refitting

- 9 Line the interior of the windscreen frame with 'Sealastrip'.
- 10 Locate the glass in the windscreen frame and press firmly into the 'Sealastrip'.
- 11 Place 'Sealastrip' around the edges of the glass to seal the angle strips when fitted.
- 12 Fit the angle strips to retain the glass and secure with the retaining screws.
- 13 Remove surplus 'Sealant'.

Soft top

- 14 Fit the windscreen to the vehicle. 76.81.02.

Hard top

- 15 Fit the fascia top rail. 76.81.04.
- 16 Fit the headlining strip.
- 17 Fit the sun visors and rear view mirror.

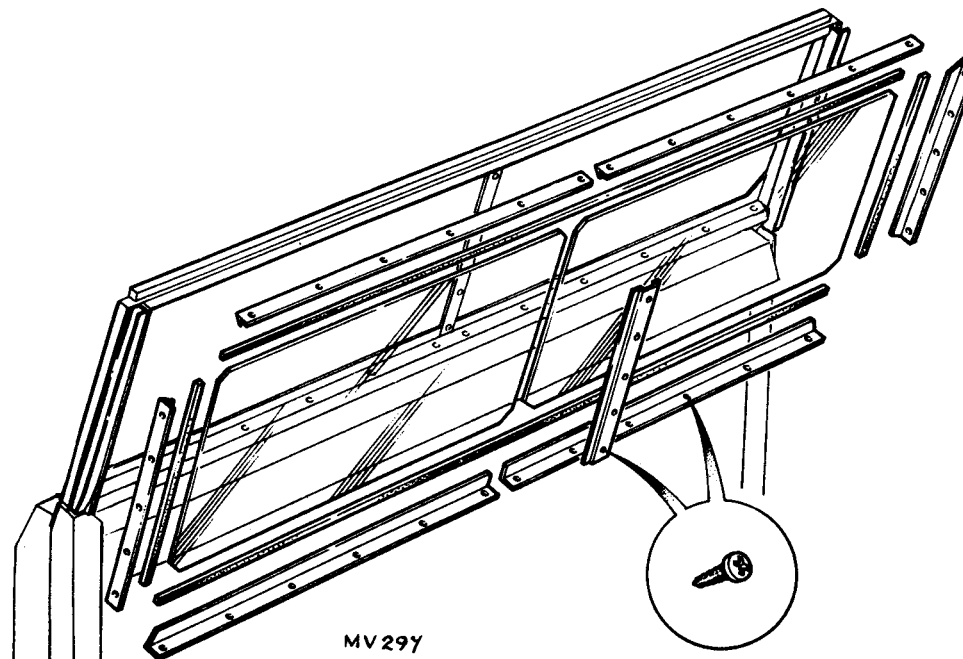

PAINTWORK

General information 78.00.00

Body panels

- 1 Land Rover body panels are manufactured from a special aluminium-alloy known as 'Birmabright' and the following paintwork procedure should be followed on these panels.

Painting 'Birmabright'

- 2 The area to be painted must be flatted to remove the hard oxide skin which forms on the surface of the alloy when exposed to the atmosphere. Degrease and dry the area, then apply a suitable etch-primer. Unless an etch-primer is used, paint is liable to come away as it cannot 'key' into the hard oxide of an untreated alloy surface and the use of ICI Etching Primer P565-5002 is recommended. It is quick and easy to apply, and it prolongs the life of the paint film by ensuring excellent adhesion.

Application

- 3 The activated Etching Primer has a limited pot-life of about 8 hours at normal temperatures and should not be used after this time, as it may have inferior adhesion and corrosion resistance. Any Etching Primer which has been mixed for more than 8 hours must be thrown away, and not returned to the can.
- 4 Apply Etching Primer as soon as possible after cleaning, and paint as soon as the pre-treatment is completed. Undue delay may cause the surface to be contaminated again and thus nullify the treatment. Do not leave pre-treated work overnight before it is painted.
- 5 Etching Primer, when followed by a suitable paint system, gives a film which is very resistant to moisture, but the Etching Primer itself is water sensitive. It should therefore be coated with paint as soon as possible when it is dry.

- 6 Activate the Etching Primer by mixing it with an equal volume of Activator P273-5021 and allow to stand for 10 minutes.
- 7 Adjust the spraying viscosity of the mixture if necessary to 22-25 sec. BSB4 Cup by adding small quantities of Thinner 851-565; never add more Activator.
- 8 Apply by spray to a clean, dry surface in a thin uniform coat, rather than a thick heavy one which may impair adhesion.
- 9 Air dry for at least 15 minutes before applying undercoat by spray or for 2 hours before brush application. If required, these times can be shortened by force drying, this also gives increased hardness to the film.
- 10 Subsequent painting follows normal paintshop practice.
- 11 When wet flatting the subsequent paint layers take care not to rub through to the Etching Primer. If this does occur allow to dry out thoroughly, dry flat the area and spot in with Etching Primer.

HEATER CONTROLS

Remove and refit

80.10.02

Removing

- 1 Remove the screws securing the heater control knobs and withdraw the control knobs. Note that the knob coloured red and blue is fitted to the inner position.
- 2 Remove the screws securing the end panel to the fascia.
- 3 Ease the end panel complete with heater control levers away from the fascia.
- 4 Remove the two screws securing the heater control assembly to the end cover. Note the two distance pieces interposed between the control lever assembly and the end panel.
- 5 Remove the end panel from the control lever assembly.
- 6 Slacken the pinch screws securing the inner cables to their respective levers.
- 7 Slacken the pinch bolt and clamp securing the outer cables to the control lever assembly.
- 8 Remove the control lever assembly.

Refitting

- 9 Reverse instructions 1 to 9. Note that the water valve control cable is connected to the inboard lever. Check the operation of both levers and controls before refitting the end panel.

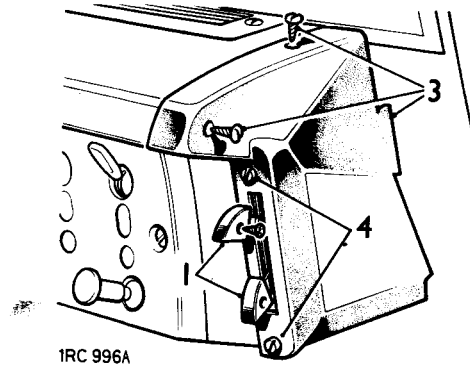

1RC 996A

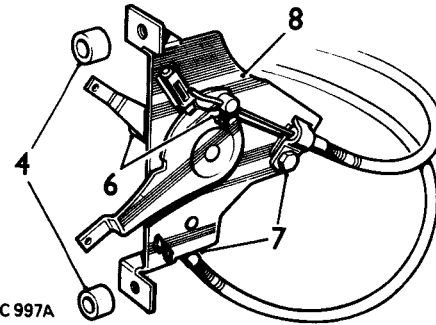

1RC 997A

HEATER/VENTILATOR AIR FLOW CONTROL CABLE

Remove and refit

80.10.06

Removing

- 1 Remove the heater controls 80.10.02 (instructions 1 to 3) and disconnect the air flow control cable.
- 2 Remove the lower fascia 76.46.05.
- 3 Remove the heater ducting cover fixings.
- 4 Withdraw the ducting cover to gain access to the air distribution flaps.
- 5 Withdraw the distribution flaps from the fascia.
- 6 Disconnect the inner cable at the flaps.
- 7 Withdraw the outer cable, retained at the ducting cover by a tubular clip.

Refitting

- 8 Reverse instructions 2 to 7.
- 9 Refit the heater controls and air flow control cable ensuring full air distributor flap operation. The flaps are easily checked after removing the air outlet ducts in the lower fascia.

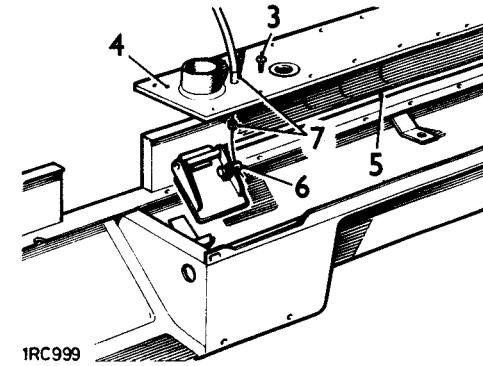

1RC 999

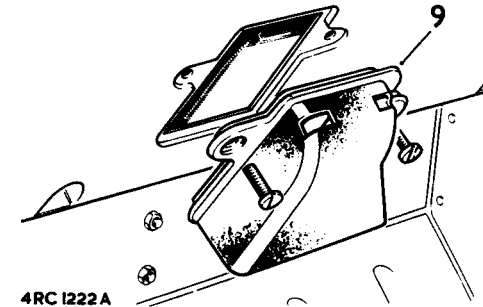

4RC 1222 A

HEATER WATER VALVE CONTROL CABLE

Remove and refit

80.10.07

Removing

- 1 Remove the heater control assembly and end cover from the fascia.
- 2 Disconnect the water valve inner and outer cable from the control lever.
- 3 Disconnect the inner and outer cable from the water valve.
- 4 Attach a length of cord or thin wire to the end of the cable. This facilitates refitting.
- 5 Withdraw the control cable leaving the cord or wire in position on the vehicle.

Refitting

- 6 Attach the control cable to the end of the cord or wire and draw the cable into position. Remove the cord or wire.
- 7 Connect the outer and inner cable to the water valve and control lever. (Water valve closed, control lever raised.)
- 8 Check lever and water valve operation and adjust as necessary.
- 9 Fit the heater control assembly and end cover to the fascia.

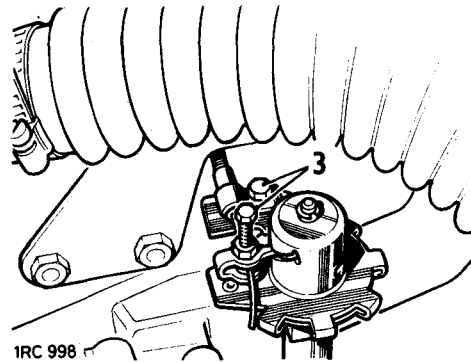

IRC 998

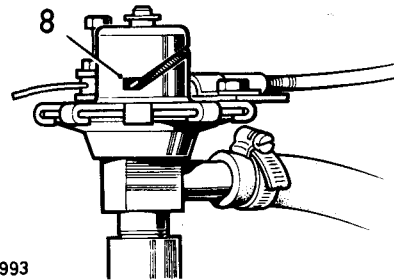

IRC 993

HEATER WATER VALVE

Remove and refit

80.10.16

Removing

- 1 Partially drain the coolant from the radiator.
- 2 Slacken the inner cable fixing.
- 3 Slacken the outer cable clamp fixing.
- 4 Free the inner cable and withdraw from the valve.
- 5 Release the heater hose clips and slide the hose away from the water valve.
- 6 Unscrew and withdraw the heater water valve complete with adaptor.
- 7 Withdraw the adaptor sealing washer.

Refitting

- 8 Reverse instructions 3 to 7; do not tighten the inner cable fixing at this stage.
- 9 Set the water valve in the closed position.
- 10 Set the cable control lever in the fully up 'cold' position.
- 11 Take up all slack in the inner cable then secure the outer cable to the water valve.
- 12 Top up the radiator.

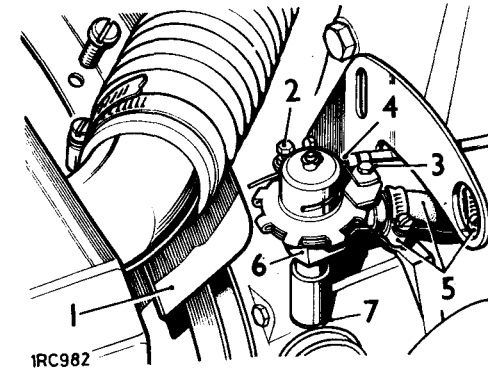

IRC982

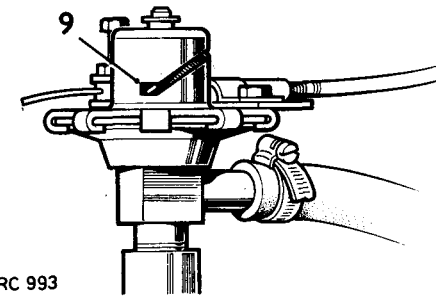

IRC 993

HEATER FAN SWITCH

Remove and refit

80.10.22

Removing

- 1 Disconnect the battery.
- 2 Remove the lock ring and wave washer securing the heater switch to the instrument panel.
- 3 Remove the two screws securing the instrument panel and ease the panel towards the steering wheel.
- 4 Release the electrical connections from the heater switch. Note the electrical connection cable colours and their relative position on the switch.
- 5 Withdraw the switch.

Refitting

- 6 Reverse instructions 1 to 5.

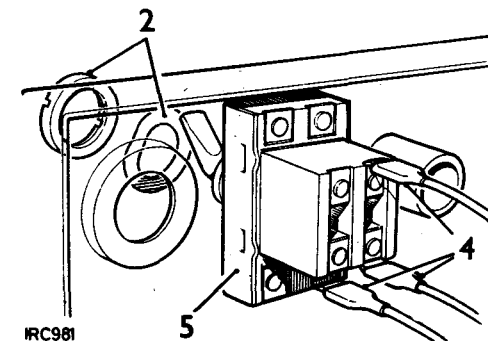

IRC981

DEMISTER HOSES

Remove and refit 80.15.01

Passenger's side hose instructions 1 to 3.
Driver's side hose instructions 4 to 7.

Removing—passenger's side hose.

- 1 Disengage the hose upper end from the nozzle adaptor.
- 2 Withdraw the hose from the rubber connector.

Refitting

- 3 Reverse instructions 1 and 2.

Removing—driver's side hose

- 4 Withdraw the instrument panel sufficient to gain access to the hose 88.20.01, instructions 1 to 5.
- 5 Disengage the hose upper end from the nozzle adaptor.
- 6 Withdraw the hose from the rubber connector.

Refitting

- 7 Reverse instructions 4 to 6.

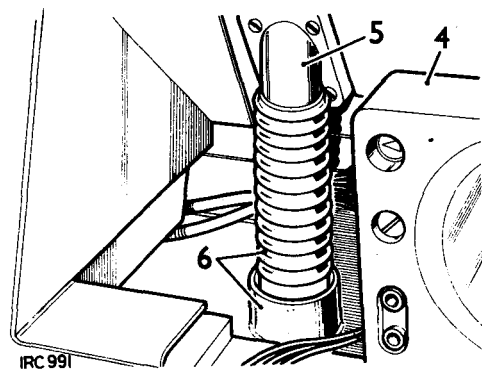
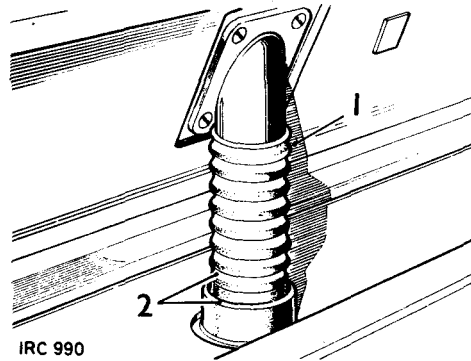

DEMISTER NOZZLES

Remove and refit 80.15.03

Passenger's side—instructions 1 to 4.
Driver's side—instructions 6 to 13

Removing—passenger's side nozzle

- 1 Remove the demister hose. 80.15.01.
- 2 Remove the fresh air grille.
- 3 Remove the nozzle adaptor.
- 4 Manoeuvre the nozzle out through the fresh air grille aperture.

Refitting

- 5 Reverse instructions 1 to 4.

Removing—driver's side nozzle

- 6 Disconnect the battery earth lead.
- 7 Remove the switch shrouds from the steering column.
- 8 Withdraw the instrument panel clear of the dash, 88.20.01, instructions 1 to 5.
- 9 Remove the fresh air grille.
- 10 Withdraw the demister hose.
- 11 Remove the nozzle adaptor.
- 12 Manoeuvre the nozzle out through the fresh air grille aperture.

Refitting

- 13 Reverse instructions 6 to 12.

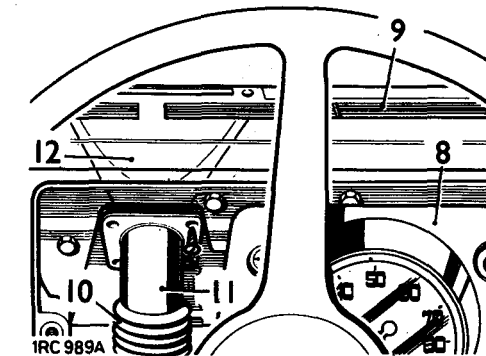
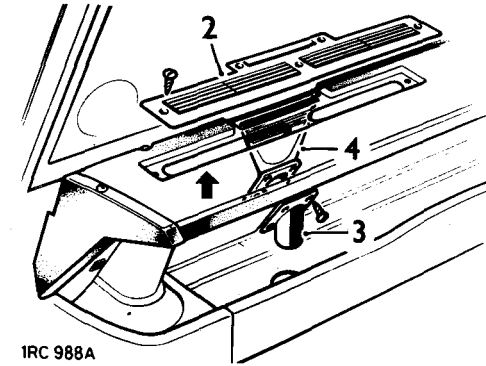

AIR DISTRIBUTION FLAPS

Remove and refit 80.15.09

This operation is described in operation 80.10.06.

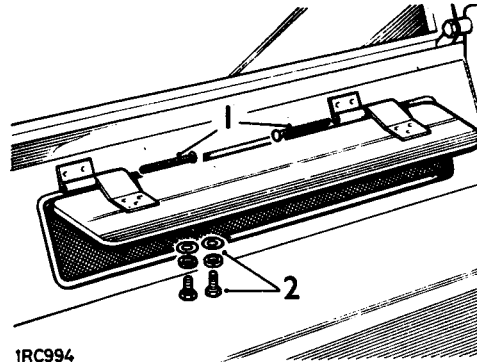

1RC994

VENTILATOR GRILLE PANEL

Remove and refit 80.15.16

Removing

- 1 Remove the hinge pins.
- 2 Remove the control lever fixings.
- 3 Remove the ventilator control to dash fixings.
- 4 Withdraw the ventilator control and quadrant assembly.

Refitting

- 5 Check the lever operation in the quadrant. If required, adjust the special locknut to alter the spring loading on the lever.
- 6 Reverse instructions 1 to 4.

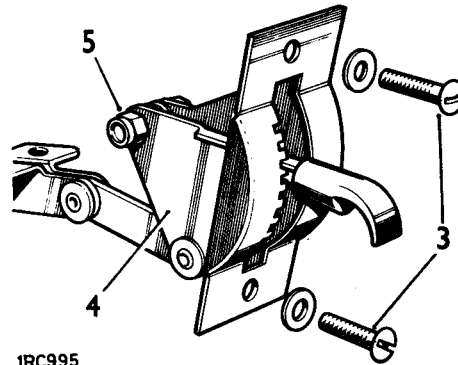

1RC995

FRESH AIR INTAKE

Remove and refit 80.15.29

Removing

- 1 Remove the fixings.
- 2 Withdraw the intake grille assembly.
- 3 If required, withdraw the air inlet seal.

Refitting

- 4 Reverse instructions 1 to 3.

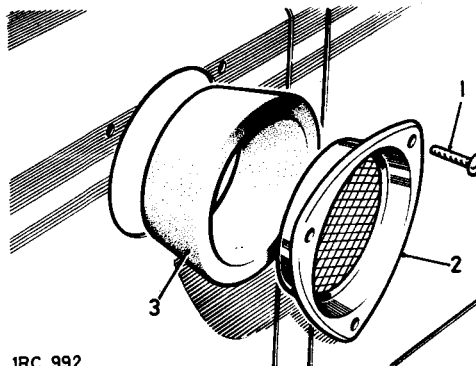

1RC 992

HEATER BOX COMPLETE

Remove and refit 1 to 7, 12 & 13 80.20.01

HEATER RADIATOR

Remove and refit 1 to 13 80.20.29

Removing

- 1 From inside the cab remove the trim board rail, if fitted.
- 2 Withdraw the trim board from the clip, if fitted.
- 3 Remove the heater box lower fixings.
- 4 Disconnect the heater water hoses.
- 5 Disconnect the air inlet hose.
- 6 Remove the heater box upper fixings.
- 7 Withdraw the heater box.
- 8 If removal of the heater radiator is required, proceed as follows, instructions 9 and 10.
- 9 Remove the fixings and withdraw the detachable side panel.
- 10 Withdraw the radiator and pipes assembly.

Refitting

- 11 If the heater radiator was removed reverse instructions 9 and 10.
- 12 Ensure that the joint seal is present and sound.
- 13 Reverse instructions 1 to 7.

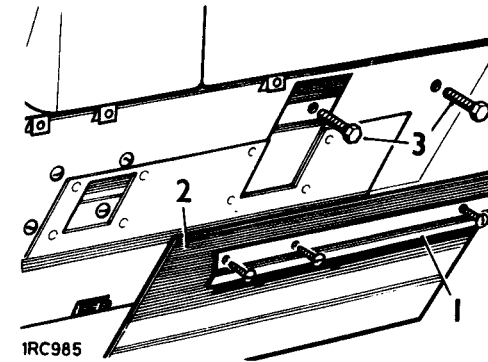

1RC985

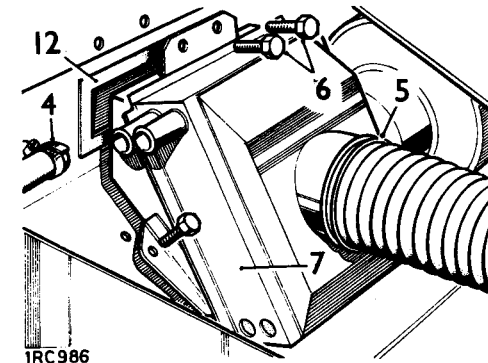

1RC986

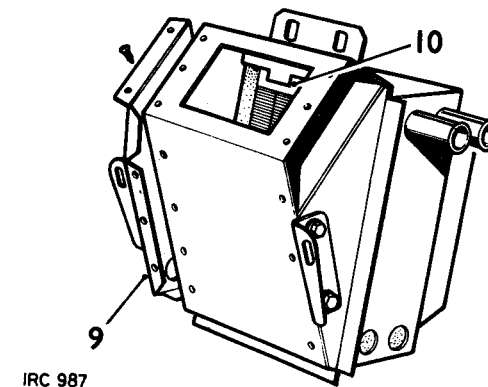

1RC 987

HEATER/BLOWER FAN MOTOR

Remove and refit

80.20.15

Removing

- 1 Disconnect the battery.
- 2 Disconnect the blower motor leads.
- 3 From inside the cab remove the trim board rail.
- 4 Withdraw the trim board from the clip.
- 5 Remove the blower motor fixings.
- 6 Disconnect the air hose at the matrix inlet.
- 7 Remove the wing panel rear top fixing bolt.
- 8 Manoeuvre the blower motor assembly clear, lifting the wing panel sufficient to allow passage.
- 9 Withdraw the air inlet seal.

Refitting

- 10 Fit the blower motor but omit the air inlet seal at this stage.
- 11 Remove the air intake grille.
- 12 Fit the air inlet seal and replace the intake grille.
- 13 Reverse 2 to 7. Connect the electrical leads from the blower motor at the snap connectors as follows: Brown lead with green marker band — to green/slate lead; green/yellow lead — to green/yellow lead.

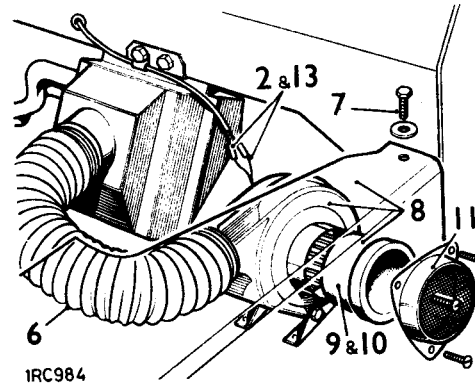
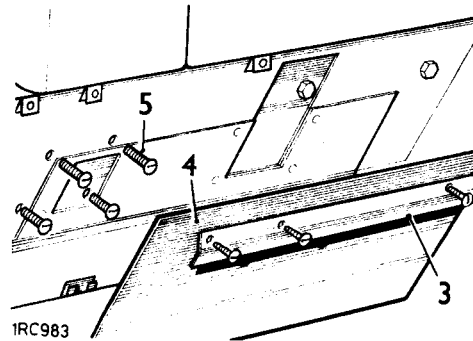

HEATER PIPES

Remove and refit

80.25.15

Feed to heater

80.25.16

Return from heater

Removing

- 1 Partially drain the coolant.
- 2 Disconnect the hoses.
- 3 Remove the fixings and withdraw the pipe.

Refitting

- 4 Reverse instructions 1 to 3.

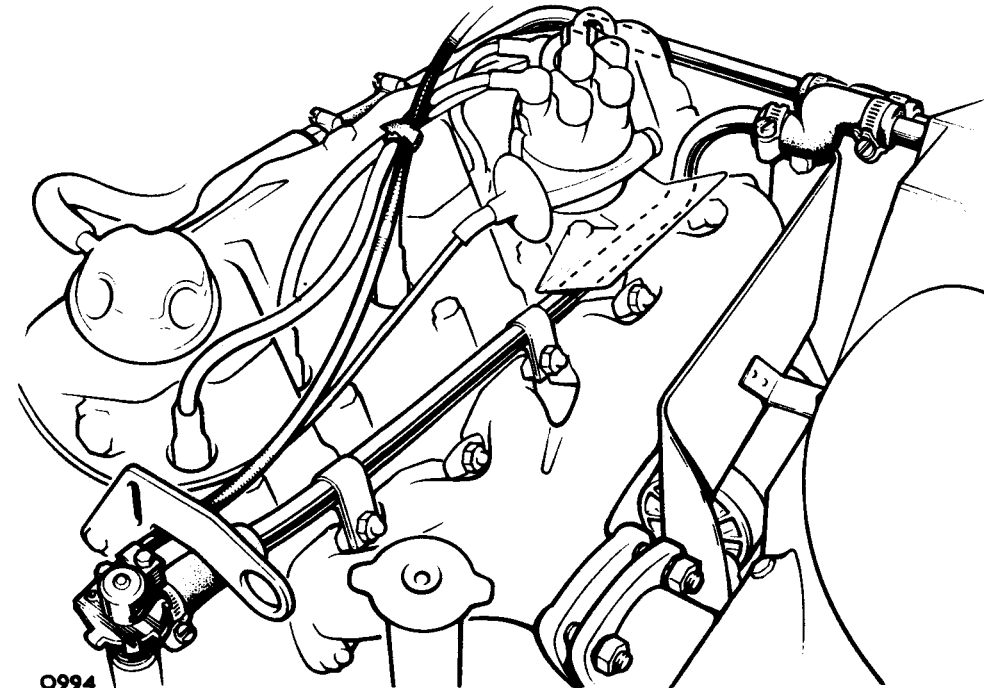
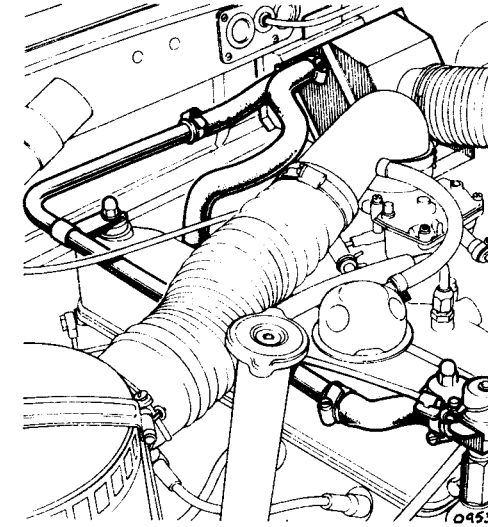

WASHER RESERVOIR

Remove and refit 84.10.01

- 1 Remove the washer reservoir filler cap complete with suction tube and filter from the reservoir.
- 2 Remove the three screws, washers and nuts securing the reservoir to the wing valance.
- 3 Remove the reservoir.
- 4 Diesel models with vacuum tank and servo only.
Removal of the washer reservoir necessitates the prior removal of the vacuum tank complete with mounting brackets and washer reservoir. For details refer 70.50.04.

Refitting

- 5 Reverse instructions 1 to 3

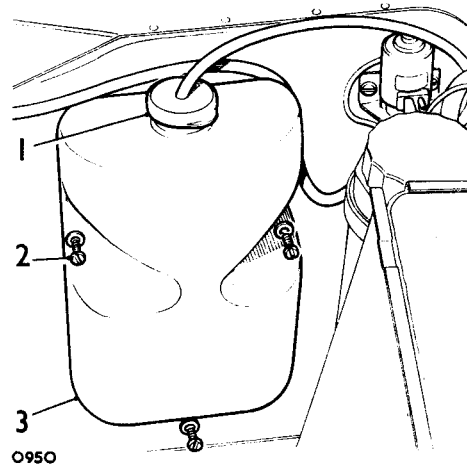

WASHER JETS

Remove and refit 84.10.09

Removing

- 1 Unscrew the washer jet.
- 2 Withdraw the jet and washer tube from the jet holder.
- 3 Detach the jet from the washer tube.

Refitting

- 4 Engage the jet in the washer tube.
- 5 Wind the jet and tube anti-clockwise approximately the number of turns required to secure the jet in the jet holder.
- 6 Push the jet and tube into the jet holder and screw the jet into position. The washer tube will unwind to its normal free position.

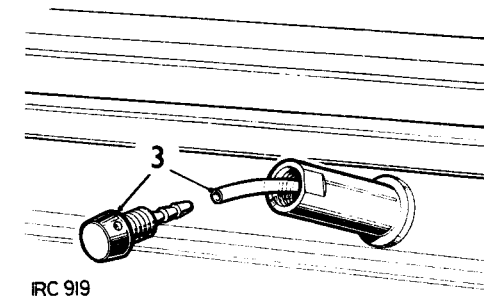

WASHER TUBES

Remove and refit 84.10.15

Removing

- 1 Disconnect the battery.
- 2 Disconnect the washer tubes from the washer pump.
- 3 Remove the washer reservoir cap and withdraw the pump inlet tube complete with filter.
- 4 Release the delivery tube (pump to car) from its retaining clips.
- 5 Unscrew the windscreen washer jets and remove the jets from the washer tubes.
- 6 Ease back the panel tray trim edging from the top of the wiper motor cover.
- 7 Remove the screws securing the wiper motor cover and withdraw the cover.
- 8 Remove the two screws securing the instrument panel and ease the panel towards the steering wheel.
- 9 Release the demist tubes from the upper fascia vents.
- 10 Remove the upper fascia.
- 11 Remove the retaining clips from the washer tubes.
- 12 Withdraw the washer tubes (3) and their connecting tee piece.

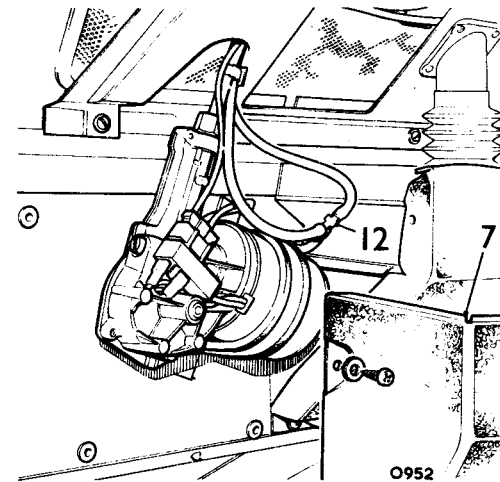

Refitting

- 13 Reverse instructions 1 to 12. When threading the tube from the tee piece to the washer pump through the bulkhead it will be found advantageous to unscrew the plate holding the washer tube grommet to the front of the bulkhead.

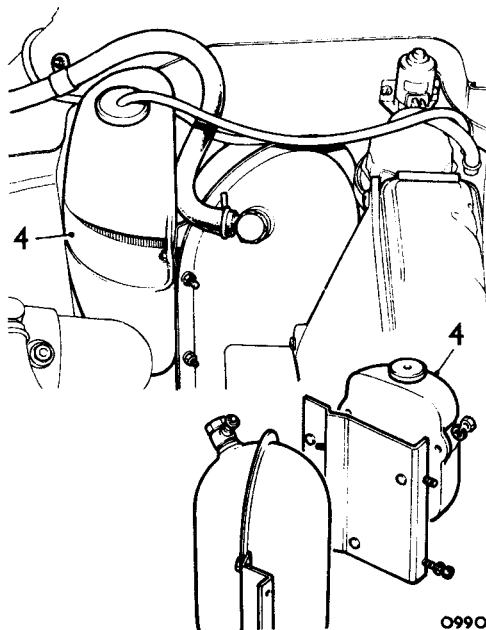
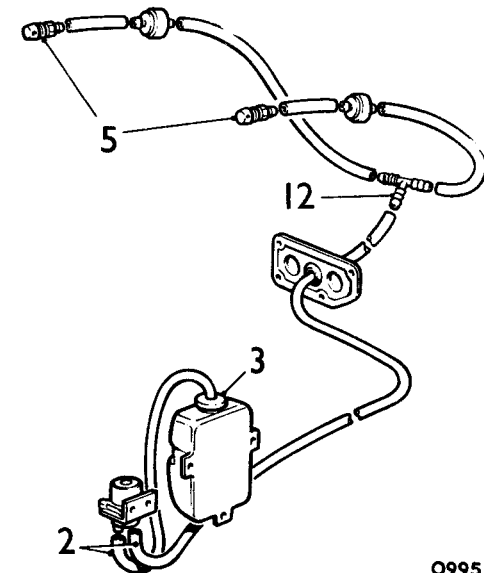

WASHER PUMP

Remove and refit

84.10.21

Removing

- 1 Disconnect the battery.
- 2 Disconnect the washer tubes from the washer pump. Note the suction tube (washer reservoir tube) is fitted to the pump union adjacent to the radiator.
- 3 Detach the electrical feed wire and earth wire from the pump.
- 4 Remove the two bolts and washers securing the pump, pump bracket and earth wire to the wing valance.
- 5 Remove the pump, pump bracket and earth wire.

Refitting

- 6 Reverse instructions 1 to 5.

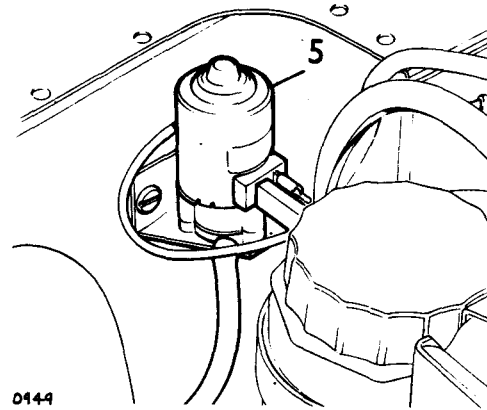
**WIPER MOTOR AND DRIVE**

Remove and refit

84.15.09

Removing

- 1 Disconnect the battery.
- 2 Remove the wiper arms.
- 3 Remove the screws securing the wiper motor cover and withdraw the cover.
- 4 Disconnect the power supply plug from the wiper motor.
- 5 Disconnect the union nut securing the wheelbox drive cable tubing to the wiper motor.
- 6 Remove the screws securing the wiper motor clamp bracket. Note that the screws engage a tapped plate on the engine side of the bulkhead.
- 7 Withdraw the wiper motor complete with clamp and wheelbox drive cable. Note the rubber pad fitted between the wiper motor and the bulkhead.

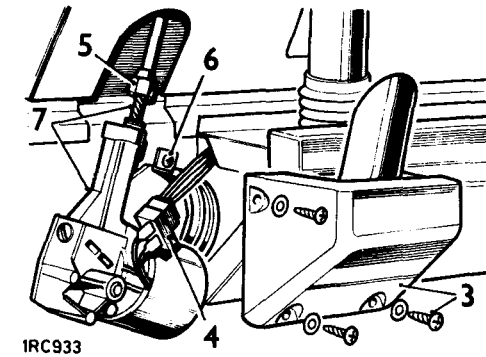
**Refitting**

- 8 Enter the drive cable in the wheelbox tubing. This may necessitate turning the wheelbox wiper spindles by hand to allow the drive cable to engage the wheelbox gears.
- 9 Reverse instructions 1 to 7.

WIPER ARMS

Remove and refit

84.15.01

Removing

- 1 Using a small screwdriver, hold back the spring clip which retains the wiper arm on the spindle.
- 2 Withdraw the wiper arm from the spindle boss.

Refitting

- 3 Allow the motor to move to the 'park' position.
- 4 Push the arm on to the boss, locating it on the splines so that the wiper blade is just clear of the screen rail.
- 5 Ensure that the spring retaining clip is located in the retaining groove on the boss.

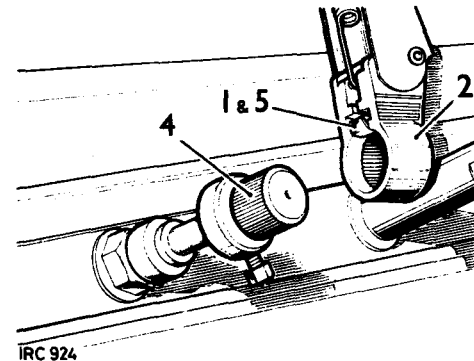

WIPER MOTOR DRIVE AND WHEELBOXES

Remove and refit

84.15.10

Removing

- 1 Disconnect the battery.
- 2 Remove the windscreen wiper arms.
- 3 Remove the drive adaptor from the wheelbox spindles.
- 4 Remove the grommet from the wheelbox spindles.
- 5 Remove the nut and washer securing the wheelboxes to the vehicle.
- 6 Remove the wiper motor and drive cable. 84.15.09.
- 7 Remove the two screws securing the instrument panel and ease the panel towards the steering wheel.
- 8 Release the demist tubes from the upper fascia vents.
- 9 Remove the upper fascia. 76.46.04.
- 10 Slacken the nuts securing the wheelbox back plates.
- 11 Release the drive cable tubes from the wheelboxes.
- 12 Remove the drive cable tubes and the wheelboxes.

Refitting

- 13 Reverse instructions 1 to 12.

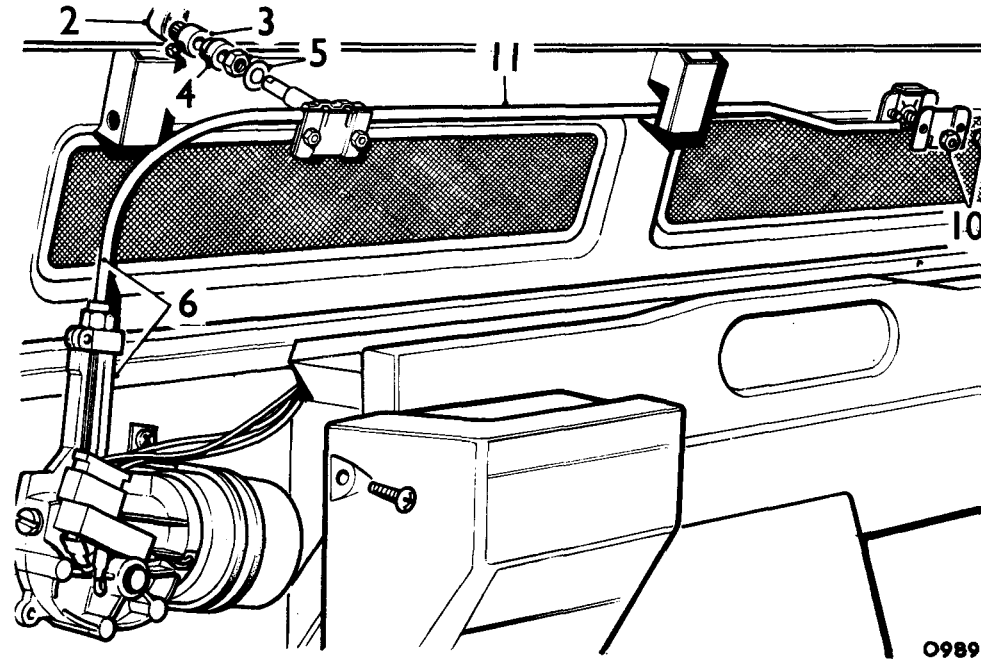

0989

WIPER MOTOR

Overhaul

84.15.18

Dismantling

- 1 Remove the wiper motor and drive. 84.15.09.
- 2 Remove the gearbox cover.
- 3 Remove the circlip and plain washer securing the connecting rod.
- 4 Withdraw the connecting rod.
- 5 Withdraw the flat washer.
- 6 Remove the circlip and washer securing the shaft and gear.
- 7 Clean any burrs from the gear shaft and withdraw the gear.
- 8 Withdraw the dished washer.
- 9 Add alignment marks to the yoke and gearbox for reassembly.
- 10 Remove the yoke securing bolts.
- 11 Withdraw the yoke and armature.
- 12 Remove the brush gear assembly.
- 13 Remove the limit switch.

Inspecting

- 14 Check the brushes for excessive wear, if they are worn to 4,8 mm (0.190 in.) in length, fit a new brush gear assembly.
- 15 Using a push type gauge, check that the brush spring pressure is 140 to 200 g (5 to 7 oz.) when the bottom of the brush is level with the bottom of the slot in the brush box. Fit a new brush gear assembly if the springs are not satisfactory.
- 16 Test the armature for insulation and open- or short-circuits. Use a test lamp (110V, 15W). Fit a new armature if faulty.
- 17 Examine the gear wheel for damage or excessive wear.

Assembling.

- 18 Reverse instructions 1 to 13 noting instructions 19 to 26.

- 19 Use Ragsine Listate Grease to lubricate the gear wheel teeth, armature shaft worm gear, connecting rod and pin, cable rack and wheelbox gear wheels.
- 20 Use Shell Turbo 41 oil sparingly to lubricate the bearing bushes, armature shaft bearing journals, gear wheel shaft and wheelbox spindles. Thoroughly soak the felt washer in the yoke bearing with oil.
- 21 Tighten the yoke fixing bolts. Torque 23 kgf. cm. (20 lbf. in.).
- 22 If a replacement armature is being fitted, slacken the thrust screw to provide end-float for fitting the yoke.
- 23 Fit the dished washer beneath the gear wheel with its concave side towards the gear wheel.
- 24 Ensure that the larger of the two washers is fitted to the crankpin beneath the connecting rod.
- 25 Armature end-float: Hold the yoke vertical with the adjuster screw uppermost. Carefully screw in the adjuster until resistance is felt then, screw back a quarter turn. This will give the required end-float.
- 26 Connect the leads between the wiper motor and the limit switch.

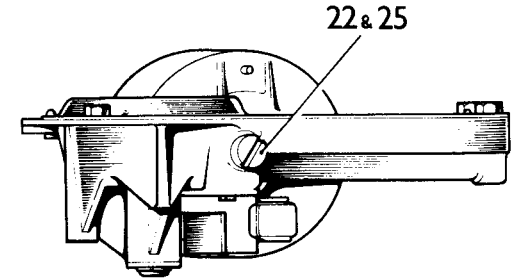

IRC 935

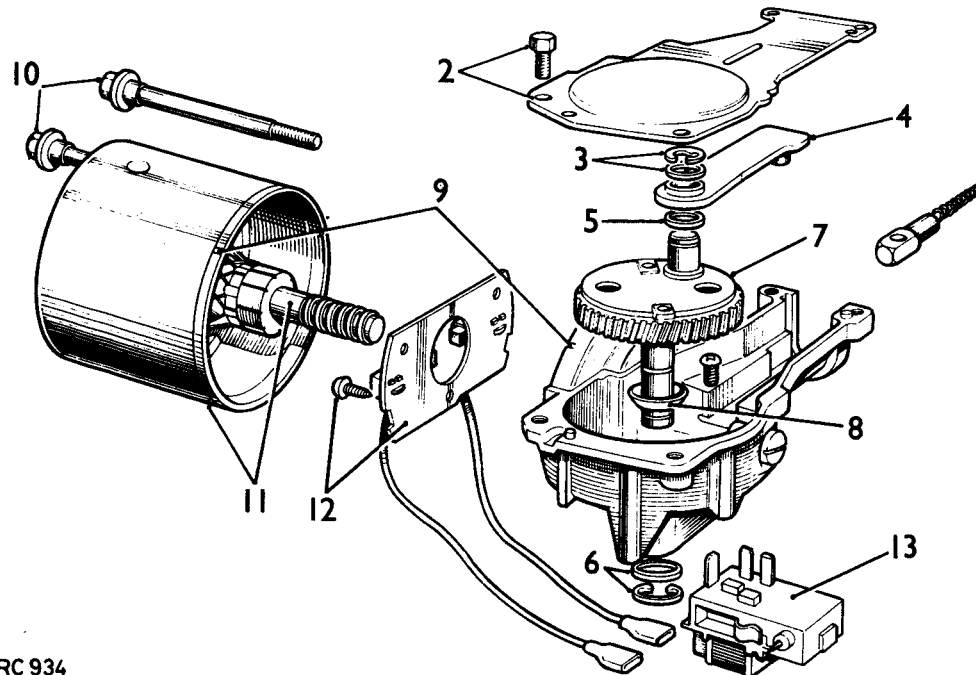

IRC 934

DATA

Windscreen wiper motor

Armature end float	0,1 mm to 0,2 mm (0.004 in. to 0.008 in.)
Brush length, minimum	4,8 mm (0.190 in.)
Brush spring tension	140 to 200 g (5 to 7 oz.)
Resistance of armature winding at 16°C (69°F) measured between adjacent commutator segments	0.23 to 0.35 ohms
Light running, rack disconnected: Current at 13.5V	2.0 amps
Speed, 60 seconds from cold	60 to 70 rev/min

HEADLAMP WIPERS AND WASHERS

General

84.20.00

For certain markets and as an optional extra, headlamp wipers and washer equipment can be fitted. This installation does not involve extra controls: the headlamp wipers and washers are engineered to function only when the headlamps are illuminated and windscreen washer is operated.

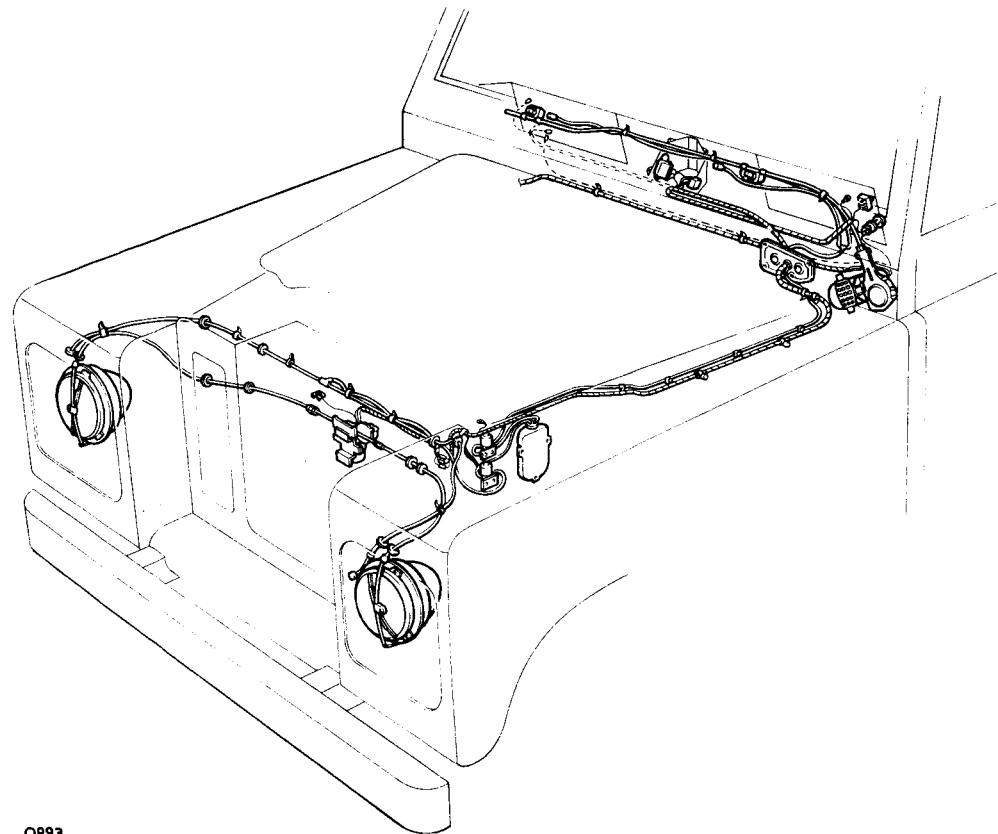

KEY TO CIRCUIT DIAGRAM

- 1 Windscreen washer pump
- 2 Vehicle washer switch
- 3 Headlamp wiper relay
- 4 Headlamp wiper delay unit
- 5 Vehicle lighting switch
- 6 Headlamp washer pump
- 7 Headlamp wiper motor

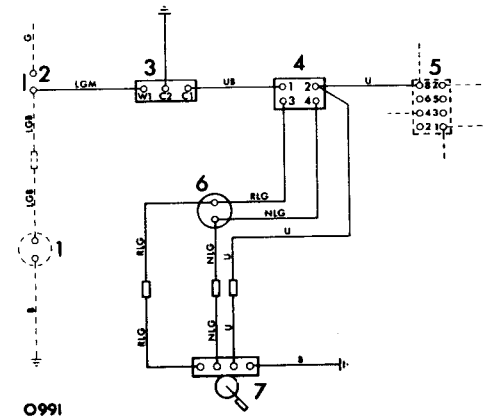

ELECTRICAL EQUIPMENT

General 86.00.00

The electrical system is Negative earth, and it is most important to ensure correct polarity of the electrical connections at all times. Any incorrect connections made when reconnecting cables may cause irreparable damage to the semiconductor devices used in the alternator and regulator. Incorrect polarity would also seriously damage any transistorised equipment such as radio and tachometer etc.

Before carrying out any repairs or maintenance to an electrical component, always disconnect the battery.

The V-drive fan belt used with alternators is not the same as that used with d.c. machines. Use only the correct Rover replacement fan belt. Occasionally check that the engine and alternator pulleys are accurately aligned.

It is essential that good electrical connections are maintained at all times. Of particular importance are those in the charging circuit (including those at the battery) which should be occasionally inspected to see that they are clean and tight. In this way any significant increase in circuit resistance can be prevented.

Do not disconnect battery cables while the engine is running or damage to the semiconductor devices may occur. It is also inadvisable to break or make any connections in the alternator charging and control circuits while the engine is running.

The electronic voltage regulator employs micro-circuit techniques resulting in improved performance under difficult service conditions. The whole assembly is encapsulated in silicone rubber and housed in an aluminium heat sink, ensuring complete protection against the adverse affects of temperature, dust, and moisture etc.

The regulating voltage is set during manufacture to give the required regulating voltage range of 14.1 to 14.5 volts, and no adjustment is necessary. The only maintenance needed is the occasional check on terminal connections and wiping with a clean dry cloth.

The alternator system provides for direct connection of a charge (ignition) indicator warning light, and eliminates the need for a field switching relay or warning light control unit. As the warning lamp is connected in the charging circuit, lamp failure will cause loss of charge. Lamp should be checked regularly and a spare carried.

When using rapid charge equipment to re-charge the battery, the battery must be disconnected from the vehicle.

BASIC CIRCUIT DIAGRAM 2¼ AND 2.6 LITRE PETROL MODELS, R.H. AND L.H. STEERING, NEGATIVE EARTH

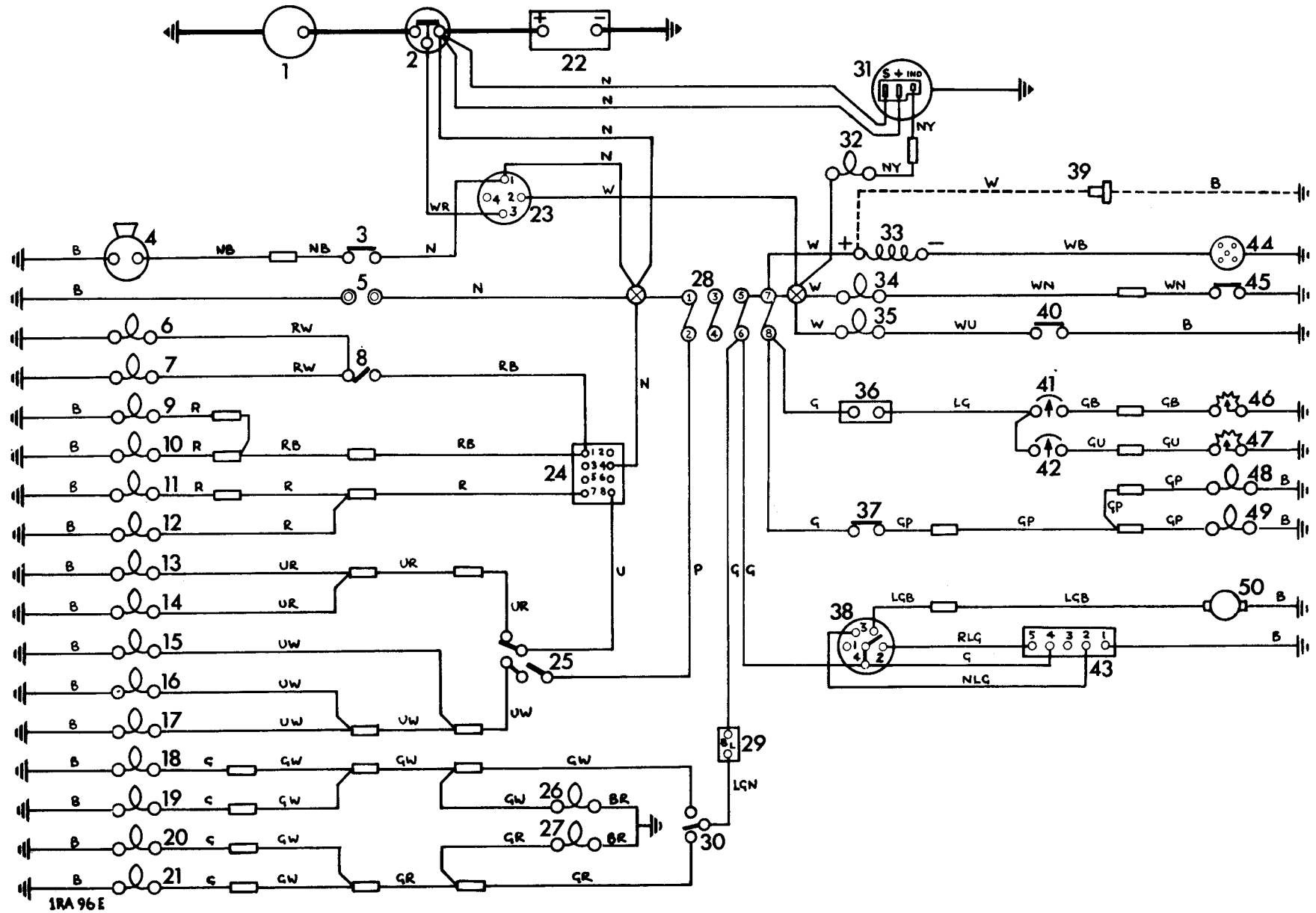

KEY TO BASIC CIRCUIT DIAGRAM 2¼ AND 2.6 LITRE PETROL MODELS, R.H. AND L.H. STEERING, NEGATIVE EARTH

- | | |
|---------------------------------------|---|
| 1 Starter motor | 26 Warning light, indicator RH |
| 2 Solenoid, starter motor | 27 Warning light, indicator LH |
| 3 Switch for horns | 28 Fuses, 1 to 8, 35 amp |
| 4 Horn | 29 Indicator unit, flasher |
| 5 Inspection sockets | 30 Switch, direction indicators |
| 6 Instrument panel illumination | 31 Alternator, Lucas 16 ACR |
| 7 Instrument panel illumination | 32 Warning light, ignition |
| 8 Switch, panel lights | 33 Ignition coil |
| 9 Tail lamp, LH | 34 Warning light, oil pressure |
| 10 Tail lamp, RH | 35 Warning light, choke |
| 11 Side lamp, LH | 36 Voltage stabiliser, fuel gauge and water temperature gauge |
| 12 Side lamp, RH | 37 Switch, stop lamp |
| 13 Headlamp, LH dipped beam | 38 Switch, windscreen wiper |
| 14 Headlamp, RH dipped beam | 39 Fuel pump, 6-cylinder models only |
| 15 Warning light, headlamp main beam | 40 Switch, cold start warning light |
| 16 Headlamp, LH main beam | 41 Fuel gauge |
| 17 Headlamp, RH main beam | 42 Water temperature gauge |
| 18 Direction indicator lamp, rear RH | 43 Screenwiper motor |
| 19 Direction indicator lamp, front RH | 44 Distributor |
| 20 Direction indicator lamp, front LH | 45 Switch, oil pressure |
| 21 Direction indicator lamp, rear LH | 46 Fuel tank unit |
| 22 Battery | 47 Water temperature transmitter unit |
| 23 Switch, ignition and starter | 48 Stop lamp, LH |
| 24 Switch, lights | 49 Stop lamp, RH |
| 25 Switch, headlamp flash and dip | 50 Screenwasher motor (when fitted) |

Key to cable colours

B	Black	R	Red
G	Green	U	Blue
L	Light	W	White
N	Brown	Y	Yellow
P	Purple		

The last letter of a colour code denotes the tracer colour

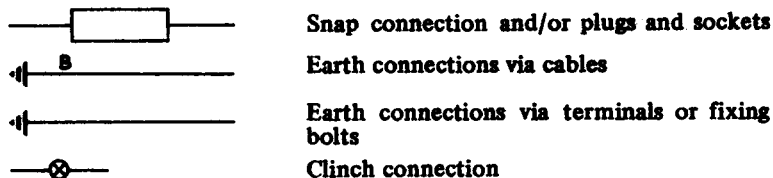

BASIC CIRCUIT DIAGRAM 2¼ LITRE 4-CYLINDER DIESEL MODELS, R.H. AND L.H. STEERING, NEGATIVE EARTH

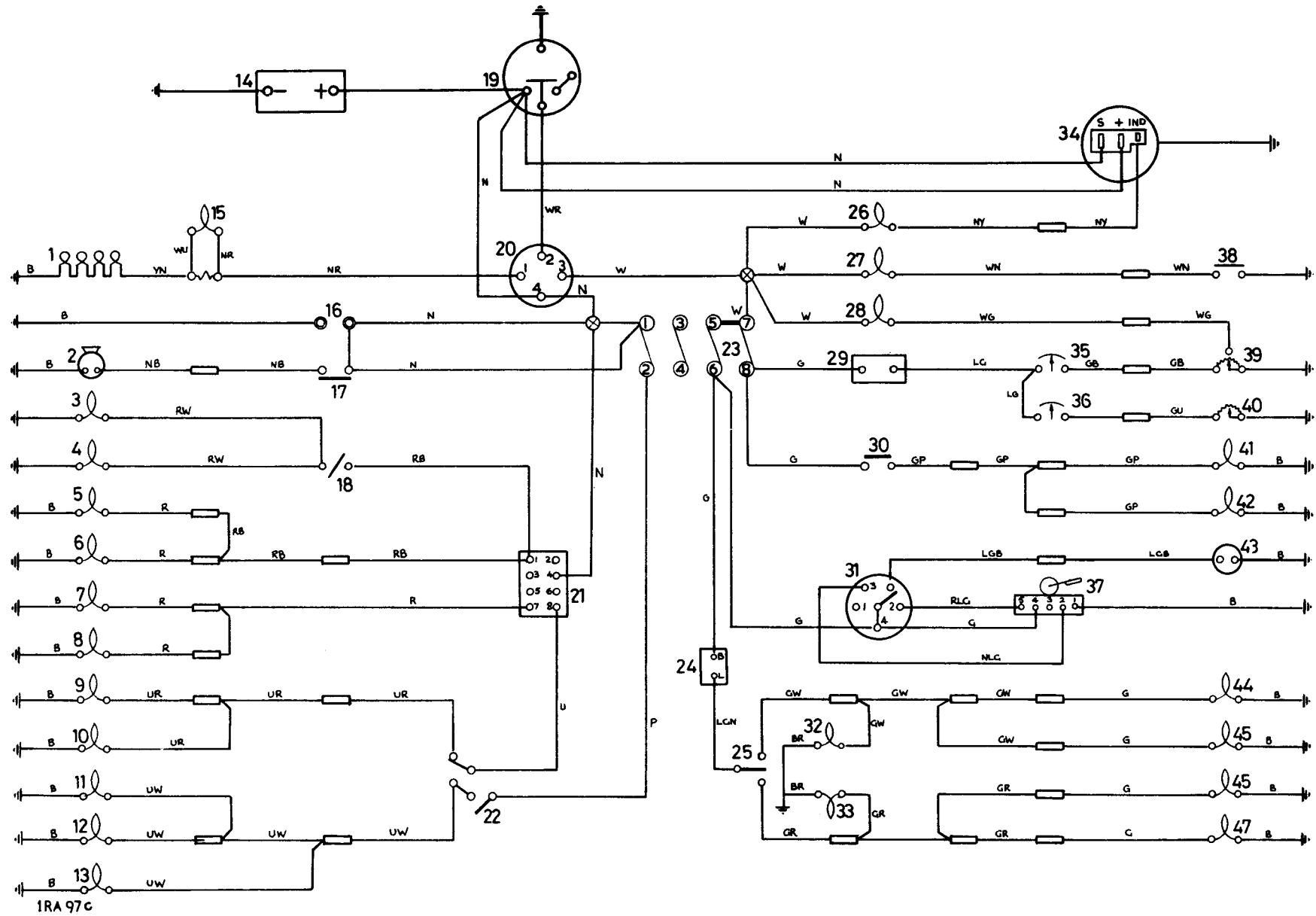





KEY TO BASIC CIRCUIT DIAGRAM 2¼ LITRE 4-CYLINDER DIESEL MODELS, R.H. AND L.H. STEERING, NEGATIVE EARTH

1 Heater plugs	26 Warning light, charge
2 Horn	27 Warning light, oil pressure
3 Instrument panel illumination	28 Warning light, low fuel level
4 Instrument panel illumination	29 Voltage stabiliser unit, fuel gauge and water temperature gauge
5 Tail lamp, LH	30 Switch, stop lamps
6 Tail lamp, RH	31 Switch, windscreen wiper
7 Side lamp, RH	32 Warning light, RH indicator
8 Side lamp, LH	33 Warning light, LH indicator
9 Headlamp, RH dipped beam	34 Alternator 16 ACR
10 Headlamp, LH dipped beam	35 Fuel gauge
11 Headlamp, LH main beam	36 Water temperature gauge
12 Headlamp, RH main beam	37 Wiper motor
13 Warning light, headlamp main beam	38 Switch, oil pressure
14 Battery	39 Fuel tank unit
15 Warning light and resistor, heater plugs	40 Transmitter, water temperature
16 Inspection sockets	41 Stop lamp, LH
17 Switch, horn	42 Stop lamp, RH
18 Switch, panel light	43 Windscreen washer motor (when fitted)
19 Solenoid, starter motor	44 Indicator, front RH
20 Switch, starter-heater plugs	45 Indicator, rear RH
21 Switch, lights	46 Indicator, rear LH
22 Switch, headlamp dip and flash	47 Indicator, front LH
23 Fuses, 1 to 8, 35 amp	
24 Indicator unit, flasher	
25 Switch, indicators	

Key to cable colours

B Black	R Red
G Green	U Blue
L Light	W White
N Brown	Y Yellow
P Purple	

The last letter of a colour code denotes the tracer colour.

	Snap connectors or plugs and sockets
	Earth connections via fixing bolts
	Earth connections via cables
	Clinch connection

CIRCUIT DIAGRAM 2¼ AND 2.6 LITRE PETROL MODELS, R.H. AND L.H. STEERING, NEGATIVE EARTH INCLUDING FOG LAMPS AND REAR FOG-GUARD LAMPS

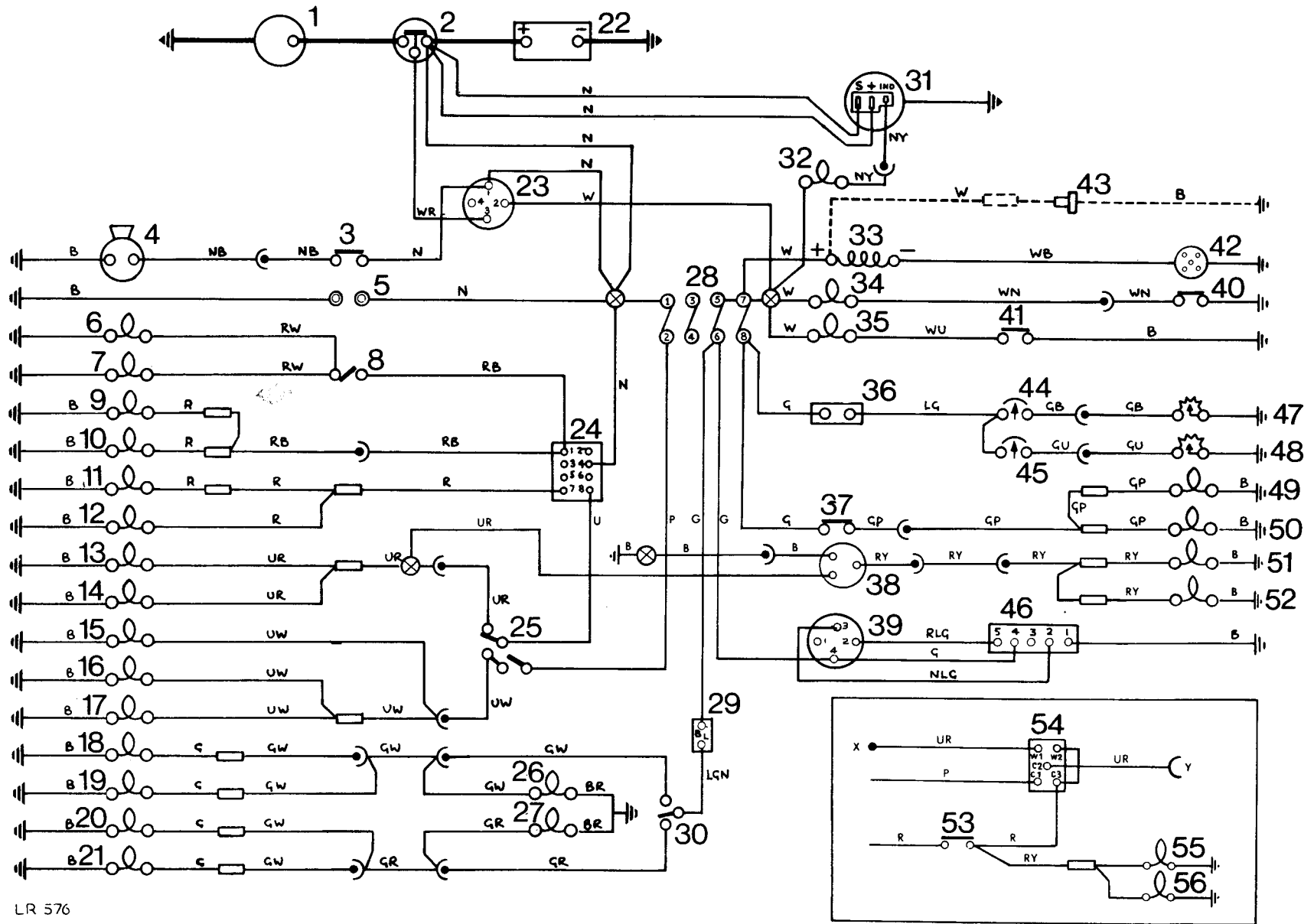

KEY TO CIRCUIT DIAGRAM 2¼ AND 2.6 LITRE PETROL MODELS, R.H. AND L.H. STEERING, NEGATIVE EARTH INCLUDING FOG LAMPS AND REAR FOG-GUARD LAMPS

- | | | |
|---|---|---|
| 1 Starter motor | 20 Direction indicator lamp, front L.H. | 38 Rear fog lamp switch and warning light |
| 2 Solenoid, starter motor | 21 Direction indicator lamp, rear L.H. | 39 Switch, windscreen wiper |
| 3 Switch for horns | 22 Battery | 40 Switch, oil pressure |
| 4 Horns | 23 Switch, ignition and starter | 41 Switch, choke |
| 5 Inspection sockets | 24 Switch, lights | 42 Distributor |
| 6 Instrument panel illumination | 25 Switch, headlamp flash and dip | 43 Fuel pump (6-cylinder models only) |
| 7 Instrument panel illumination | 26 Warning light, indicator R.H. | 44 Fuel gauge |
| 8 Switch, panel lights | 27 Warning light, indicator L.H. | 45 Water temperature gauge |
| 9 Tail lamp, L.H. | 28 Fuses, 1 to 8, 35 amp | 46 Screenwiper motor |
| 10 Tail lamp, R.H. | 29 Indicator unit, flasher | 47 Fuel tank unit |
| 11 Side lamp, L.H. | 30 Switch, direction indicators | 48 Water temperature transmitter |
| 12 Side lamp, R.H. | 31 Alternator, Lucas 16 ACR | 49 Stop lamp, L.H. |
| 13 Headlamp, L.H. dipped beam | 32 Warning light, ignition | 50 Stop lamp, R.H. |
| 14 Headlamp, R.H. dipped beam | 33 Ignition coil | 51 Rear fog lamp, R.H. |
| 15 Warning light, headlamp main beam | 34 Warning light, oil pressure | 52 Rear fog lamp, L.H. |
| 16 Headlamp, L.H. main beam | 35 Warning light, choke | 53 Front fog lamp switch |
| 17 Headlamp, R.H. main beam | 36 Voltage stabilizer, fuel gauge and water temperature gauge | 54 Fog lamp change over relay |
| 18 Direction indicator lamp, rear R.H. | 37 Switch, stop lamp | 55 Front fog lamp, L.H. |
| 19 Direction indicator lamp, front R.H. | | 56 Front fog lamp, R.H. |

Key to cable colours

- | | |
|----------|----------|
| B Black | R Red |
| G Green | U Blue |
| L Light | W White |
| N Brown | Y Yellow |
| P Purple | |

The last letter of a colour code denotes the tracer colour.

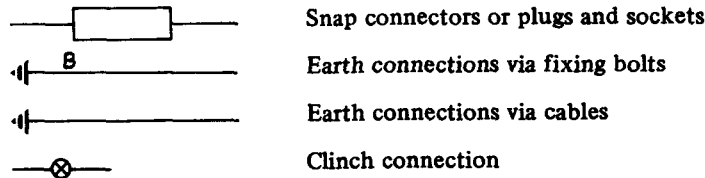

CIRCUIT DIAGRAM 2 1/4 LITRE 4-CYLINDER DIESEL MODELS, R.H. AND L.H. STEERING, NEGATIVE EARTH INCLUDING FOG LAMPS AND REAR FOG-GUARD LAMPS

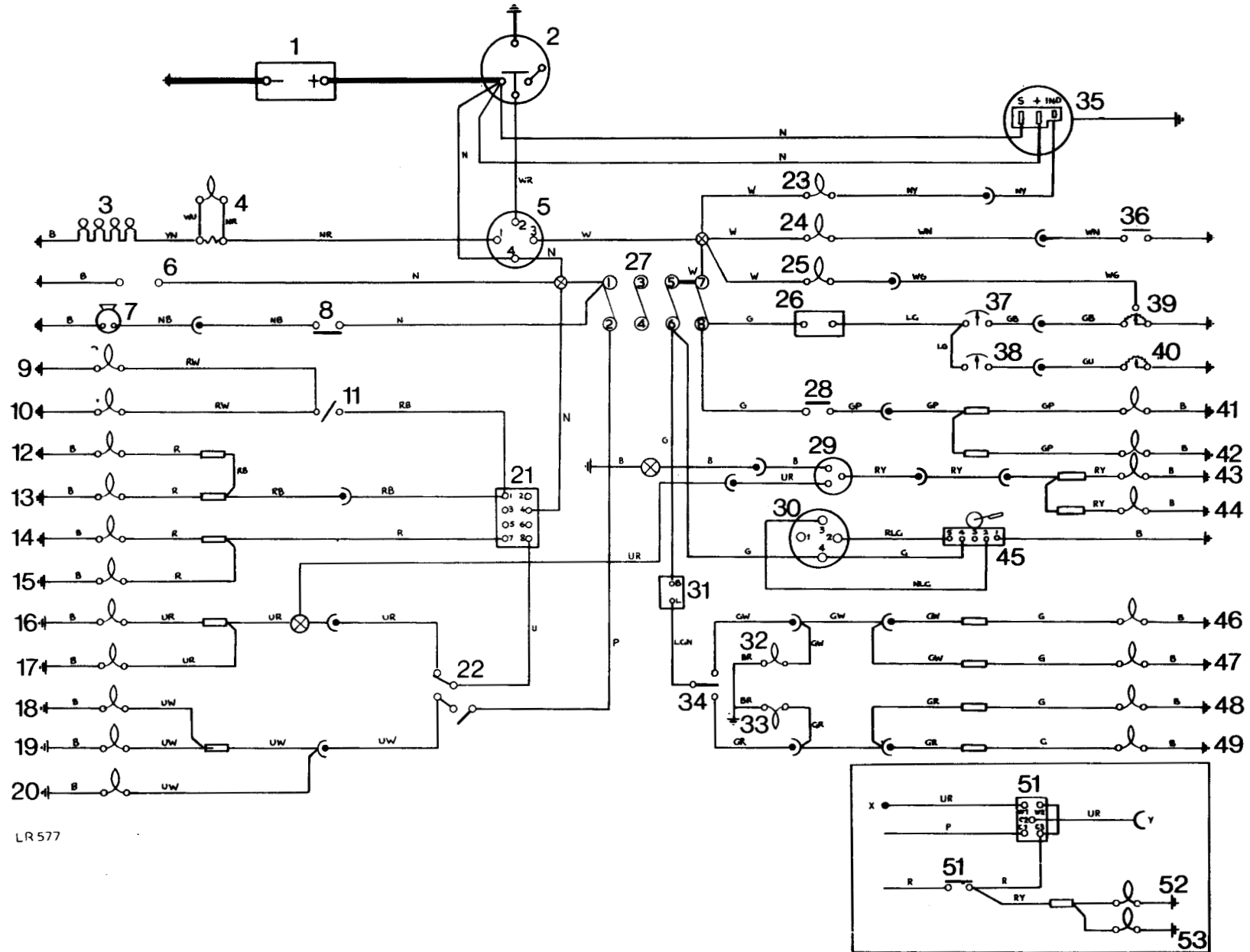

KEY TO CIRCUIT DIAGRAM 2¼ LITRE 4-CYLINDER DIESEL MODELS, R.H. AND L.H. STEERING, NEGATIVE EARTH INCLUDING FOG LAMPS AND REAR FOG-GUARD LAMPS

1	Battery	19	Headlamp, R.H. main beam	37	Fuel gauge
2	Starter motor solenoid	20	Headlamp main beam warning light	38	Water temperature gauge
3	Heater plugs	21	Lighting switch	39	Fuel tank unit
4	Cold start warning light and resistor	22	Switch, headlamp dip and flash	40	Water temperature transmitter
5	Start solenoid and switch	23	Charge warning light	41	Stop lamp, L.H.
6	Inspection sockets	24	Oil pressure warning light	42	Stop lamp, R.H.
7	Horn	25	Warning light, low fuel level	43	L.H. rear fog-guard lamp
8	Horn switch	26	Voltage stabilizer unit	44	R.H. rear fog-guard lamp
9	Instrument panel illumination	27	Fuses	45	Wiper motor
10	Instrument panel illumination	28	Stop lamp switch	46	R.H. front indicator
11	Panel light switch	29	Rear fog-guard lamp switch and indicator	47	R.H. rear indicator
12	Tail lamp, L.H.	30	Windscreen wiper switch	48	L.H. rear indicator
13	Tail lamp, R.H.	31	Flasher indicator unit	49	L.H. front indicator
14	Side lamp, R.H.	30	R.H. indicator warning light	50	Fog lamp change over relay
15	Side lamp, L.H.	33	L.H. indicator warning light	51	Front fog lamp switch
16	Headlamp, R.H. dipped beam	34	Indicator switch	52	L.H. front fog lamp } (if fitted)
17	Headlamp, L.H. dipped beam	35	Alternator	53	R.H. front fog lamp }
18	Headlamp, L.H. main beam	36	Oil pressure switch		

Key to cable colours

B	Black	R	Red
G	Green	U	Blue
L	Light	W	White
N	Brown	Y	Yellow
P	Purple		

The last letter of a colour code denotes the tracer colour

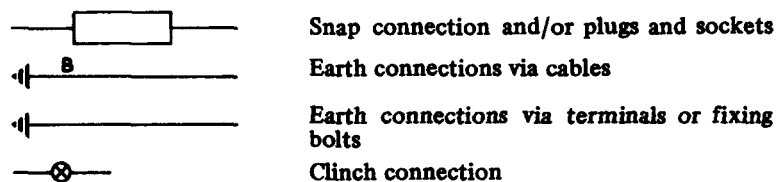

Alternator—Description

The mechanical features of the alternator are a rotor supported by two ball bearings. No periodic lubrication is required. The field winding carried on the rotor is energized via a pair of brushes and slip-rings. Cooling air is drawn through the unit by a fan mounted at the drive end.

Electrically an alternating current produced in the three-phase, star-connected static stator windings is rectified by six diodes—three on the live side and three on the earth side—to supply direct current to the vehicle electrical circuits and battery.

The field winding circuit is energized by part of the stator output which is rectified by the three field winding supply diodes.

The integral control unit is electrically positioned in the field winding earth return path. Until a measure of control is required terminal 'F' is connected via the output transistor to earth. As the alternator output rises, the reference voltage felt at terminal 'S' rises. When control is required the solid state switching circuit governed by the voltage sensitive electronic circuit turns the output transistor off. The control unit thus finely adjusts the current flow through the field winding to balance the alternator output to suit the electrical requirements of the vehicle and the state of charge of the battery.

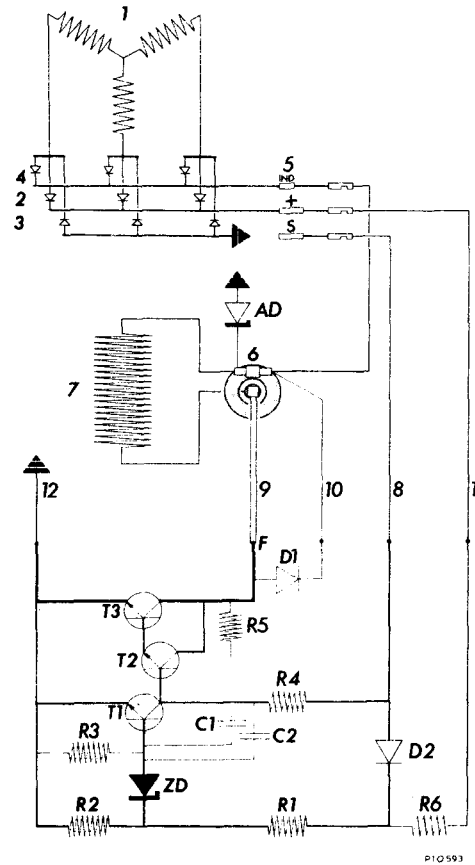

ALTERNATOR WIRING DIAGRAM

Lucas 16ACR alternator with 14TR regulator

KEY

1	Stator windings	
2	Live side output diodes	
3	Earth side output diodes	
4	Field winding supply diodes	
5	European terminations	IND Ignition warning light + Main to battery S Sense to battery
6	Brushes and slip rings	
7	Field winding	
8	Battery sensed lead—white	
R4	Resistor	Restricts TS base current supplied from 'battery sensed lead'.
T2	Intermediate transistor	Controls T3 base current direct.
9	Metal connector link	
T3	Output transistor	Controls field winding earth return circuit.
R1 and R2	Resistors	Potential divider – used in normal operation. Senses battery reference voltage.
ZD	Zener diode	Voltage sensitive component. Opposes passage of current until breakdown voltage – approximately 8 volts – is reached. Controls T1 base current direct.
T1	Input transistor	Controls T2 base current by diverting current passing through R4 to earth when ZD is conducting.
C1 and R5	Capacitor and resistor	Prevents transistor overheating by providing positive feedback circuit to ensure quick switching of transistors from 'fully on' to 'fully off'.
R3	Resistor	Path for small leakage current which may pass through ZD at high temperatures.
10	Surge lead – yellow	
D1	Surge quench diode	Connected across field winding. Protects T3 from field winding high induced voltage surge and smooths field winding current.
C2	Condenser	Radio interference suppression.
11	Machine sensed lead – red	
R6	Resistor	Fail safe component. If main alternator to battery wire disconnects battery sensed lead voltage will fall. Alternator runaway voltage is clamped by high voltage on machine sensed lead. Modified potential divider R, R2 and addition R6.
D2	Diode	Fail safe component. If battery sensed lead disconnects alternator shuts down as supply via R4 to transistors T2 and T3 stops. D2 blocks feed into this circuit from machine sensed lead via R6.
AD	Avalanche diode	Protects output transistor from high transient voltage which may occur from faulty charging circuit connections.
12	Earth lead – black	Regulator earth.

ALTERNATOR DATA

CAUTION: The alternator contains polarity sensitive components that may be irreparably damaged if subjected to incorrect polarity.

Do not connect or disconnect any part of the charging circuit—including the battery leads—while the engine is running. Run the alternator with all connections made or with the unit disconnected.

NOTE: Identify the unit on the specific vehicle to ensure that information obtained from this manual refers to the appropriate alternator.

Manufacturer	Lucas
Type	16 ACR Dual sensed—battery sensed with machine sensed safety control European terminations
Polarity	Negative earth only
Brush length—new	0.5 in (12.70 mm)
—renew if less than	0.2 in (5.00 mm) protrudes from brushbox when free
Brush spring pressure	9 to 13 oz (255 to 370 g) at face flush with brushbox
Rectifier pack—output rectification	6 diodes (3 live side and 3 earth side)
—field winding supply rectification	3 diodes
Stator windings	Three phase—star connected
Field winding rotor	
—poles	12
—maximum permissible speed	15,000 rev/min
—shaft thread	$\frac{9}{16}$ in — 18 U.N.F.
Field winding resistance at 20°C	3.3 ± 5% ohm
Regulator—type	14TR
Nominal output—condition	Hot
—alternator speed	6000 rev/min
—engine speed	3000 rev/min
—control voltage	14 volt
—amp	34 amp

ALTERNATOR

Functional check 86.10.01

This operation must be performed in two parts. The first to prove the alternator's capacity to produce current. The second to prove the performance of the integral regulator.

Check capacity to produce current

NOTE: The stated output may be exceeded slightly when the alternator is cold. To avoid misleading results, the check should be performed with the unit as near

to its normal operating temperature as possible.

- 1 Check drive belt adjustment 86.10.05.
- 2 Disconnect the multi-socket connector.
- 3 Remove the cover, see 86.10.08, and provide a suitable probe and wire to enable the field winding earth brush to be earthed direct thus by-passing the regulator.
- 4 Provide a test circuit as shown.

CAUTION: The alternator contains polarity sensitive components that may be irreparably damaged if subjected to incorrect polarity. Observe polarity of alternator and battery terminals.

continued

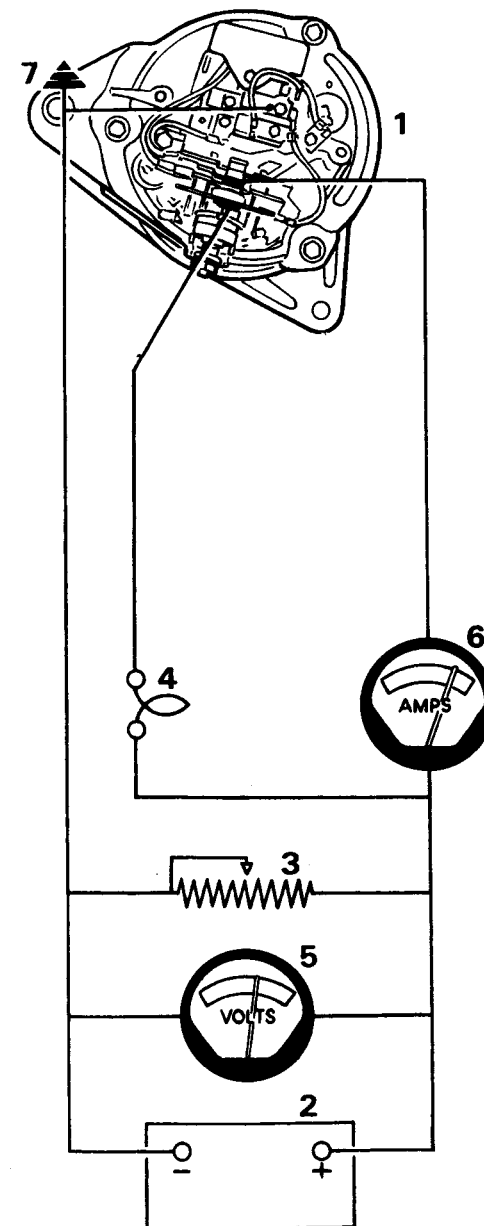

Test circuit

- | | | |
|---|-------------------------------------|------------------|
| 1 | Alternator | 12 volt |
| 2 | Battery | 12 volt |
| 3 | Variable resistor | 70 amp |
| 4 | Light | 12 volt—2.2 watt |
| 5 | Voltmeter | 0—20 volt |
| 6 | Ammeter | 0—40 amp |
| 7 | Earth connection to alternator body | |

LR 863

- 5 Do not connect the variable resistor across the battery for longer than is necessary to perform the check.
- 6 Run the engine.
- 7 Gradually increase the speed. At 1550 alternator rev/min (775 engine rev/min) the light should be extinguished.
- 8 Hold the speed at approximately 6000 alternator rev/min (3000 engine rev/min). Adjust the variable resistor so that the voltmeter reads 14 volts. The ammeter reading should now be approximately equal to the nominal output given in data.
- 9 If the ammeter reading is not correct the indication is that the alternator requires overhaul or replacement.

Diodes

- 10 Failure of one or more of the diodes will be indicated by the effect on alternator output, and in some instances by abnormally high alternator temperature and noise level. The fault symptom table shows how diode failure will influence alternator output test results. (Refer to 'Overhaul' 86.10.08, paragraph 19 for diode tests.)

continued

DIODE FAULT SYMPTOMS

Warning Light	Temperature	Noise	Output	Probable Fault (Associated Damage)
Illuminated at stand-still, extinguished at cut-in speed (1,500 rev/min) but at higher speeds becomes partially illuminated again and gets progressively brighter	High	Normal	Higher than normal at 6,000 rev/min. Approximately 40A	Live-side main output diode open circuit. (May damage rotor field winding and regulator, overheat, brushboxes, and fuse warning light bulb)
Not illuminated between zero at 1,500 rev/min	High	Excessive	Very low at 6,000 rev/min. Approximately 10A	Live-side main output diode short circuit. (May damage associated 'field' diode)
Illuminated at stand-still, dims appreciably at cut-in speed (1,500 rev/min) and gets progressively dimmer or may be extinguished at higher speeds	Normal	Excessive	Poor at low speed Slightly below normal at 6,000 rev/min. Approximately 32A	Earth-side main output diode open circuit
Illuminated at stand-still, dims appreciably at cut-in speed (1,500 rev/min) and gets progressively dimmer or may be extinguished at higher speeds	Normal	Normal	Lower than normal at 6,000 rev/min. Approximately 29A	'Field' diode open-circuit
Illuminated at stand-still, dims at cut-in speed (1,500 rev/min) and remains dim, but may be extinguished at very high speeds	Normal	Excessive	Very low at all speeds above cut-in (1,500 rev/min). Approximately 7A	Earth-side main output diode short-circuit, or stator winding short-circuit to earth
Illuminated at stand-still, dims at cut-in speed (1,500 rev/min) and remains dim, but may be extinguished at very high speeds	Normal	Excessive	Very low at 6,000 rev/min. Approximately 7A	'Field' diode short-circuit

Check-Control unit

NOTE: The stated output may be exceeded slightly when the alternator is cold. To avoid misleading results, the check should be performed with the unit as near to its normal operating temperature as possible.

- 11 Check drive belt adjustment 86.10.05.
- 12 Disconnect multi-socket connector.
- 13 Provide a test circuit as shown.

CAUTION: The alternator contains polarity sensitive components that may be irreparably damaged if subjected to incorrect polarity. Observe polarity of alternator and battery terminals.

- 14 Run the engine.
- 15 Gradually increase the speed. At 1550 alternator rev/min (775 engine rev/min) the light should be extinguished.
- 16 Hold the speed at approximately 6000 alternator rev/min (3000 engine rev/min). The voltmeter reading should now be steady at 13.6 to 14.4 volts.
- 17 If the voltmeter reading is not steady at the above figure—and a satisfactory 'Check capacity to produce current' has been performed—the indication is that the control unit should be replaced.

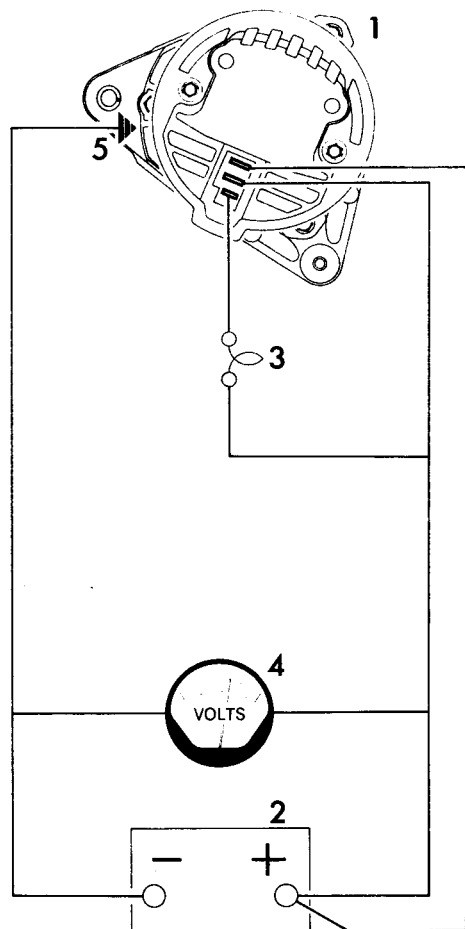

- | | | |
|---|------------------|--------------------|
| 1 | Alternator | |
| 2 | Battery | 12 volt |
| 3 | Light | 12 volt-2.2 watt |
| 4 | Voltmeter | 0-20 volt |
| 5 | Earth connection | to alternator body |

ALTERNATOR

Remove and refit

86.10.02

Removing

- 1 Disconnect the battery.
- 2 Withdraw the electrical harness plug from the rear of the alternator.
- 3 Slacken the alternator fixings.

NOTE: The accompanying illustration shows an alternator installed on a 2¼ litre 4-cylinder engine. On 2.6 litre 6-cylinder engines the alternator is mounted on the opposite side of the engine.

- 4 Pivot the alternator inwards and release the fan belt from the pulley.
- 5 Remove the fixings and withdraw the alternator.

Refitting

- 6 Fit the alternator, locating the fan belt over the pulley, but do not tighten the fixings at this stage.

CAUTION: When pivoting the alternator, leverage must only be applied to the alternator drive end bracket. Pressure applied to the stator or slip ring end bracket may result in serious damage.

- 7 2¼ litre 4-cylinder Petrol and Diesel engines

Adjust the fan belt to give 6,5 mm to 9,5 mm (0.250 to 0.375 in.) free movement when checked midway between the fan and alternator pulleys.

- 8 2.6 litre 6-cylinder Petrol engines

Adjust the fan belt to give 8,0 mm to 11,0 mm (0.312 to 0.437 in.) free movement when checked midway between the fan and crankshaft pulleys.

- 9 Reconnect the electrical harness plug to the rear of the alternator.
- 10 Connect the battery.

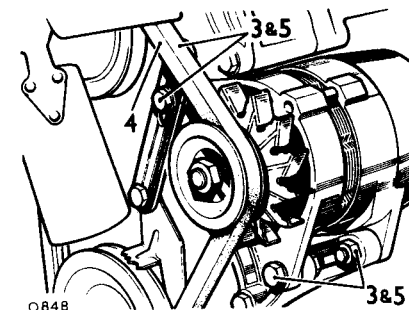

O848

3&5

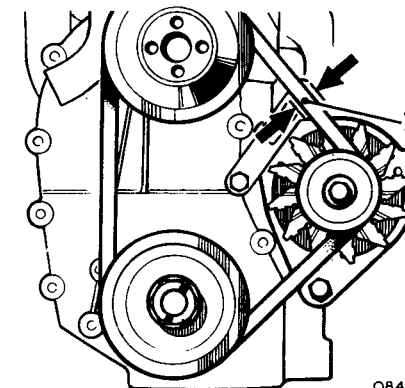

O849

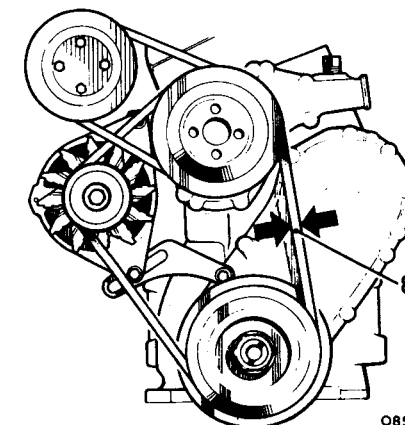

O850

ALTERNATOR—12 Volt (Lucas 16 ACR)

Overhaul

86.10.08

- 1 Remove the alternator 86.10.02.
- 2 Carry out Bench test 86.10.14.
- 3 The following dismantling instructions are sufficient to enable the brushgear and slip-rings to be thoroughly inspected and serviced and the rotor and stator-windings and rectifier diodes to be electrically tested. If it is necessary to completely dismantle the alternator in order to renew a faulty part, refer to paragraphs 23–38.
- 4 Remove the moulded slip-ring end cover (two bolts).
- 5 Note the location of the three stator winding connections to the rectifier diode connecting pins, and then using a thermal shunt (long-nosed pliers are suitable) and a light weight soldering iron (25 watt) unsolder the connections to the rectifier. Use only resin cored solder for re-soldering.
- 6 Unclip the three leads from the rectifier plates.
- 7 Slacken the rectifier securing nut and detach the rectifier from the rest of the alternator.
- 8 Remove the hexagon-headed screw retaining the surge device lead to the brushbox moulding.
- 9 Remove the two hexagon-headed screws, securing the brushbox moulding to the end-face of the slip-ring end bracket. The brushgear-and-regulator sub-assembly can now be detached from the rest of the alternator.
- 10 To release the regulator remove the hexagon-headed screw retaining the yellow and orange leads to the brushbox moulding and the single bolt securing the regulator case.

NOTE: To ensure correct re-connection of the regulator, brushgear and rectifier see paragraph 36.

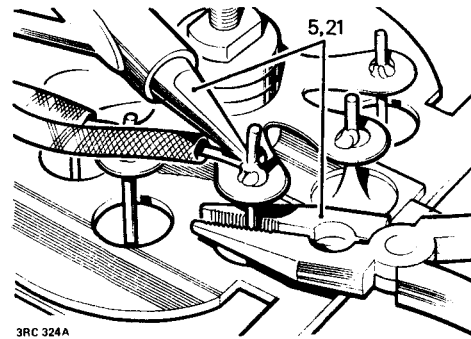

Brushgear

- 11 Check the brush spring pressure. With the brush-and-spring assemblies fitted in the brushbox moulding, apply a push-type spring gauge to the end-face of each brush in turn until the end-face of the brush is flush with the moulding. The spring pressure should then be 9–13 ozf (255–368 gmf).

Rotor slip-rings

- 12 The slip-rings should be clean and smooth. If necessary, clean the slip-rings with a petrol moistened cloth. If the slip-rings are burnt and require refinishing, use very fine glass paper (not emery cloth, or similar abrasives) and afterwards wipe clean with a petrol-moistened cloth.

NOTE: It is essential that the re-finishing glass paper is sufficiently fine to produce a highly polished slip-ring surface, otherwise excessive brush wear will occur.

Electrical testing of components

- 13 For clarity, illustrations of electrical testing show the components separated from the rest of the alternator.

Rotor field winding

- 14 Check field winding continuity and resistance simultaneously, by connecting either a battery-operated ohmmeter (see 14 a) or a 12 V battery and moving-coil ammeter (see 14 b) between the slip-rings. The ohmmeter should indicate the appropriate resistance given in the General Data (86.10.14 sheet 4), or the ammeter should indicate a current approximate to the figure obtained by dividing the appropriate resistance of the rotor into the battery voltage.
- 15 Check for satisfactory field winding insulation by connecting a 110 V A.C. 15-watt test lamp between either of the slip-rings and the rotor body. The lamp should not light.

Stator windings

- 16 Due to the very low resistance of the stator windings, a practical test to determine the presence of short-circuited turns cannot be carried out without the use of special instruments. However, in practice inter-winding short-circuiting is usually indicated by obvious signs of burning of the insulating varnish covering the windings. If this is the case, renew the stator assembly without the need for further testing.
- 17 Check continuity of stator windings, by first connecting any two of the three stator winding connecting cables in series with a 12 V battery-operated test lamp, of not less than 36 watts. The test lamp should light. If not, renew the stator assembly. Providing the first part of the test is satisfactory, transfer one of the test lamp leads to the other (third) cable. Again the test lamp should light. If so, proceed to insulation test.
- 18 Check insulation of stator windings, by connecting a 110 V A.C. 15-watt test lamp between the stator laminations and any one of the three connecting cables. The lamp should not light.

continued

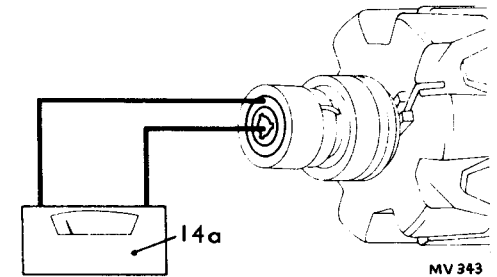

MV 343

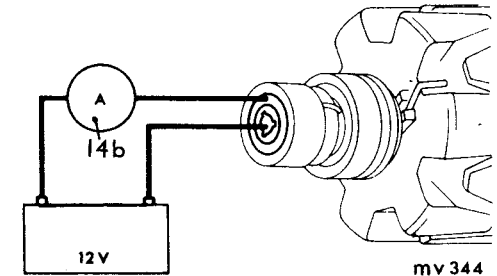

mv 344

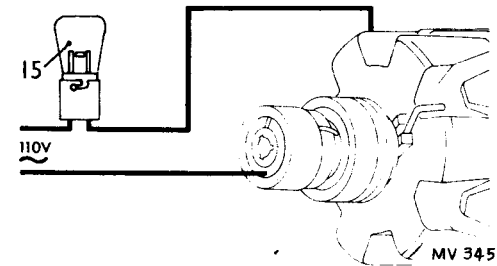

MV 345

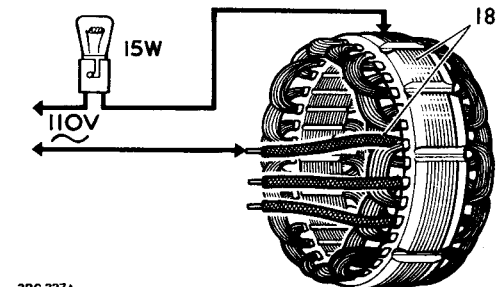

3RC 327A

Rectifier diodes

- 19 Test each of the nine diodes separately, as follows.
- 20 Connect a 12 V battery and a 1.5 watt bulb in series with one of the diodes, one test lead being applied to the diode connecting pin and the other to the particular heat sink plate in which the diode undergoing test is soldered. Note whether lamp lights, then reverse the test lead connections. The lamp should light during one half of the test only. If any one diode test is unsatisfactory, renew the rectifier assembly.
- 21 During reassembly of the alternator, use only 'M' grade 45-55 resin-cored solder to attach the stator cables to the diode connecting pins. Carry out the operation as quickly as possible, using a thermal shunt to avoid damaging the diode(s) (Long-nosed pliers are suitable as a thermal shunt).

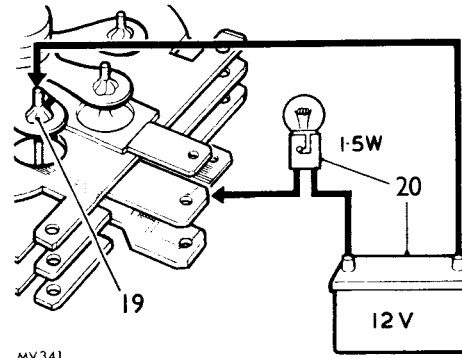

- 26 Separate the rotor assembly from the drive-end bracket. First remove the driving pulley fan and shaft key, then press the rotor shaft from the bearing in the bracket. Alternatively, use the open jaws of a vice to support the bracket and carefully drive the rotor shaft from the bearing by a series of light blows applied to the end of the shaft with a hide, plastic, or wooden mallet. (Open the jaws of the vice sufficient only to clear the rotor poles, position the bracket off-set to the centre of the top of the vice to avoid

the slip-ring moulding fouling the bottom of the vice, and temporarily fit the shaft nut flush with the end of the shaft to avoid damage to the shaft threads by the mallet).

27 If it is necessary to renew either the slip-ring moulding assembly or slip-ring end bearing the slip-ring moulding assembly can be withdrawn from the key-way in the rotor shaft after the field winding connections have been unsoldered. Use a light weight soldering iron (e.g. 25 watt). Use only resin-cored solder for resoldering.

continued

Regulator

- 22 Individual testing of the regulator can only be carried out with special test equipment and unless this is available the regulator must be proved by substitution.

Alternator—complete dismantling

- 23 Remove the three through bolts.
- 24 Grip both ends of the alternator in the hands, pull apart the end brackets from the stator laminations and separate the alternator into three major parts.
- (1) Slip-ring end bracket.
 - (2) Stator laminations-and-windings.
 - (3) Sub-assembly comprising:
 - Fan and pulley;
 - Drive-end bracket and bearing;
 - Rotor complete with slip-ring end bearing.
- 25 If difficulty is experienced in separating the above parts, suspend the alternator gripped by the pulley in one hand and apply a series of light blows with a hide, plastic, or wooden mallet in turn to the shoulders of the through bolt housings of the slip-ring end bracket.

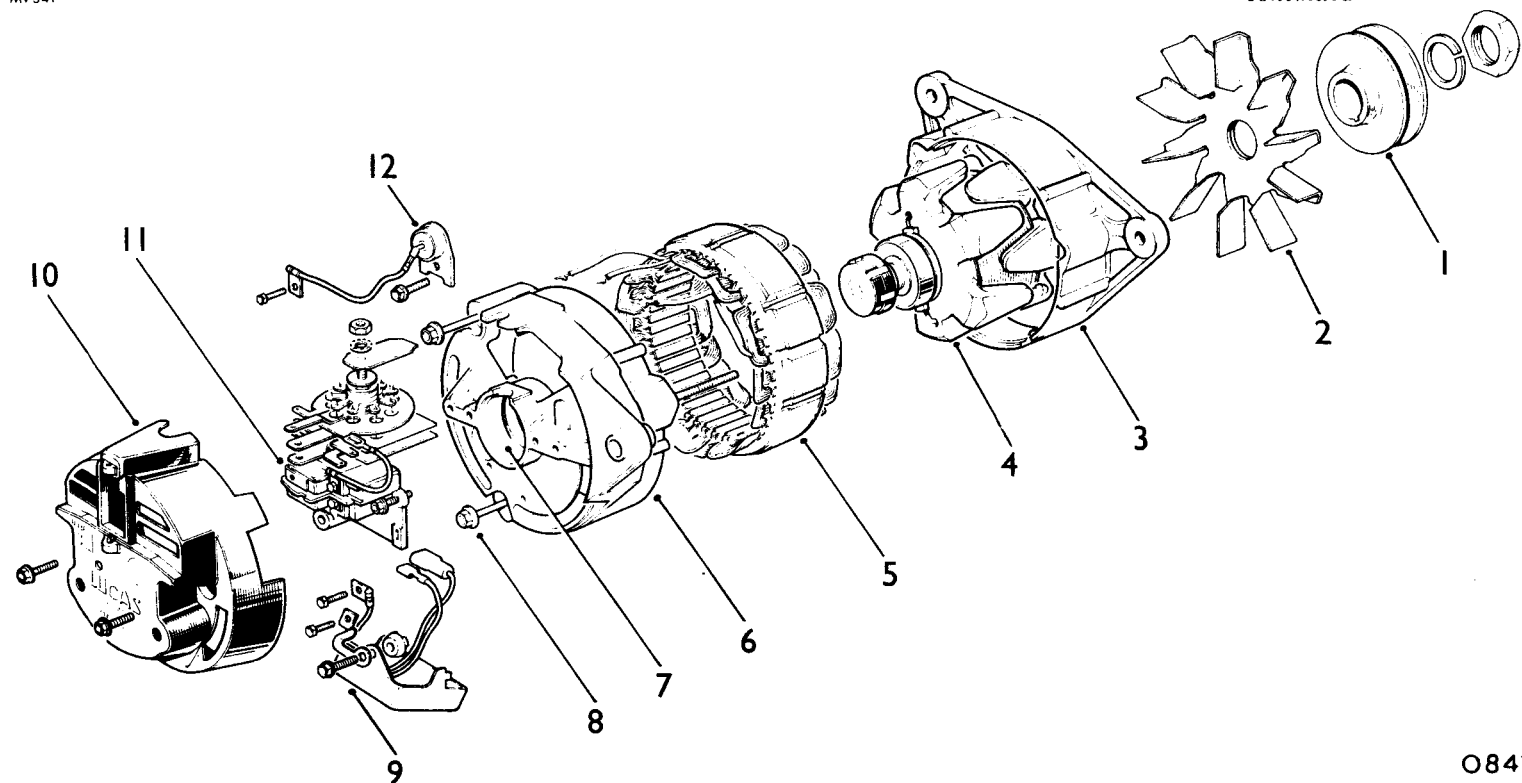

16 ACR Alternator

- | | | |
|-----------------------|-------------------------|---------------------------------------|
| 1 Pulley | 5 Stator | 9 Regulator |
| 2 Fan | 6 Slip ring end bracket | 10 Moulded end cover |
| 3 Drive end bracket | 7 'O' ring | 11 Rectifier |
| 4 Rotor and slip-ring | 8 Through bolts | 12 Surge protection (Avalanche) diode |

O847

Bearings

28 Check whether the bearings need renewing. Determine this by first inspecting the rotor and stator poles for signs of rubbing. If so, excessively worn bearings are indicated and both should be renewed. If there is no visible evidence of worn bearings, check whether the bearings are worn to the extent of allowing perceptible side movement of the rotor shaft and if so the bearing(s) should be renewed.

Renewing the bearings

29 After removing the slip-ring moulding from the rotor shaft (refer to paragraph 27), the slip-ring end bearing can be removed from the rotor shaft and then either renewed or if otherwise satisfactory re-packed with grease lubricant (refer to paragraph 32). Position the two halves of the support plate of a hand-operated power press beneath the shoulder of the nylon distance-piece and press the rotor shaft from the bearing. Alternatively, use a suitably-sized claw-type bearing extractor tool (position claws behind the shoulder of the nylon distance-piece) and pull the bearing from the shaft.

NOTE: When refitting the bearing, ensure the shielded side of the bearing faces the slip-ring moulding.

30 After removing the bearing retaining circlip and plate, the drive-end bearing can either be pressed or carefully tapped from the bracket with a suitably-sized mandrel inserted in the outer-face aperture of the bearing housing.

NOTE: When refitting the bearing, ensure correct sequence of assembly of sundry parts associated with the bearing.

Lubrication of bearings

31 During major overhaul of the alternator, providing the bearings have been checked and found not to be excessively worn, bearings can be serviced by re-packing with Shell Alvania 'RA' grease lubricant, or equivalent.

32 To re-pack the slip-ring end bearing with grease it will be necessary to gain access to the unshielded (open) side of the bearing, by removing first the slip-ring moulding and then the bearing from the rotor.

Reassembly

33 Reassembly of the alternator is simply a reversal of the dismantling procedure. It should be noted that the sub-assembly comprising rotor and drive-end bracket, stator assembly and slip-ring end bracket (secured by three through bolts) can be incorrectly assembled in two or three alternative ways which causes mis-alignment of the alternator fixing lugs of each end bracket.

34 Assuming the rotor assembly to be already fitted in the drive-end bracket, mis-alignment of the end brackets previously referred to can be avoided by first fitting the stator assembly correctly in the drive-end bracket. (In preference to first fitting the stator assembly in the slip-ring end bracket).

35 Fit the stator assembly in the drive-end bracket so that the stator connecting leads are positioned between and in line with the alternator fixing lugs, then assemble the slip-ring end bracket to the stator lamination and finally secure into a sub-assembly by fitting the through bolts.

36 Avoid over-tightening the through bolts, the maximum tightening torque is 55 lbf in (63 cmf. kg).

37 Tighten the shaft nut to a torque figure of 25 to 30 lbf. ft. (3,5 to 4,2 kgf. m.).

38 Reconnect the leads between the regulator, brushbox and rectifier as illustrated.

39 Refit the alternator 86.10.02.

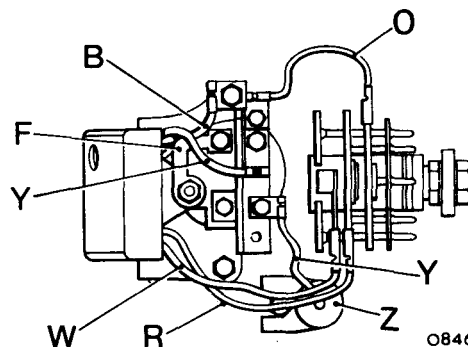

12 volt 16 ACR alternator connections

- B black lead
- F metal link
- O orange lead
- R red lead
- W white lead
- Y yellow lead
- Z surge protection

BATTERY

Remove and refit

86.15.01

Removing

- 1 Disconnect the battery leads.
- 2 Remove the air cleaner 19.10.08 (6 cyl. petrol models only).
- 3 Remove the wing nuts securing the battery clamp frame.
- 4 Remove the clamp frame.
- 5 Remove the battery.

Refitting

- 6 Reverse instructions 1 to 5.

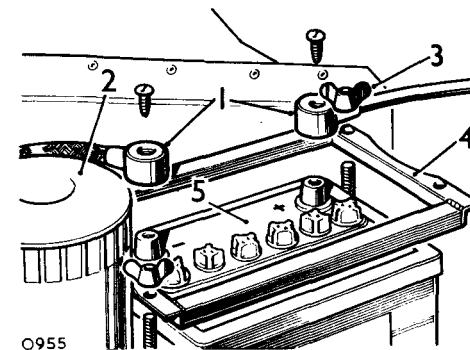
**IMPORTANT NOTE**

If a new battery is fitted to the vehicle, it should be the same type as fitted to the vehicle when new; see Section 04. Alternative batteries may vary in size and terminal positions and this could be a possible fire hazard if the terminals or leads come into contact with the battery clamp assembly. When fitting a new battery ensure that the terminals and leads are clear of the battery clamp assembly.

HORN

Remove and refit

86.30.09

Removing

- 1 Disconnect the battery.
- 2 Remove the radiator grille.
- 3 Disconnect the electrical leads from the horn.
- 4 Remove the bolts securing the horn.
- 5 Withdraw the horn.

Refitting

- 6 Reverse instructions 1 to 4.

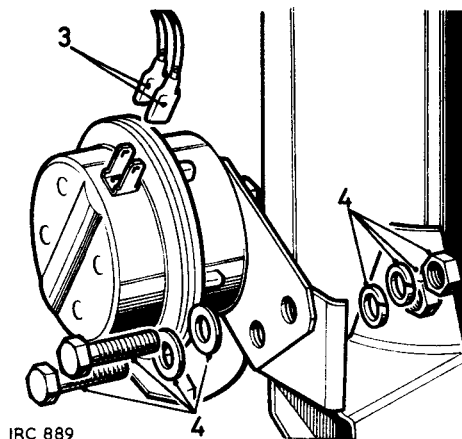

HEATER PLUGS

Remove, clean and refit

86.35.08

Removing

- 1 Disconnect the battery.
- 2 Remove the knurled terminal nuts from the heater plugs.
- 3 Detach the heater plug leads and insulators.
- 4 Remove the heater plugs.

Cleaning

- 5 Remove carbon from base of heater plugs to avoid the possibility of short circuiting of the element. Do not sandblast.
- 6 Examine the element for signs of fracture and deterioration and the seating for scores. Plugs with fractures or doubtful elements must be renewed. Where scoring of the seating may impair the sealing, the plug should be renewed.
- 7 Test the plug internal circuit for continuity by connecting it in circuit with a 12 volt side lamp bulb and a 12 volt supply. If the bulb does not light an open circuit is indicated and the heater plug must be renewed.

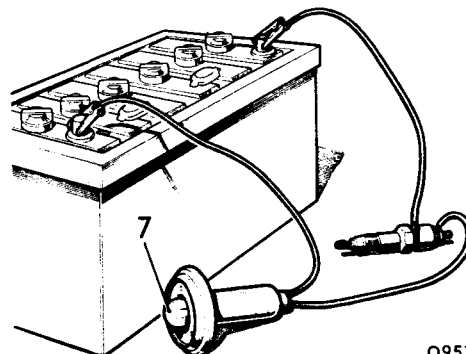
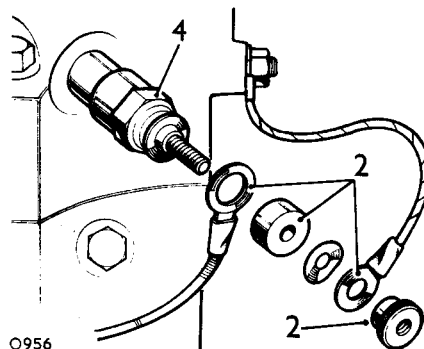

Refitting

- 8 Ensure that the terminals are clean and that the thread at the base of the plug is free from carbon.
- 9 Fit the heater plugs to the engine. Torque 3,4 kgf. m. (25 lbf. ft.).
- 10 Fit the heater plug leads and insulators.
- 11 Connect the battery.

Fault location in heater plug circuit, plugs in situ

The heater plugs do not require any maintenance. However, if at any time when the heater plugs are in use, the warning light glows very brightly, a short circuit in the system is indicated. No light will indicate an open circuit.

Great care must be taken not to twist the centre terminal when removing heater plug leads.

- 12 Examine the fuse in the fuse box and fit a new replacement if necessary. Refer to the applicable circuit diagram for fuse location.
- 13 Failure of the warning light bulb will not affect the heater plug circuit, but the bulb should be replaced when conveniently possible.
- 14 Connect one lead of a 12 volt test lamp to the earth lead terminal on No. 1 heater plug and the other lead to the positive terminal of the battery.
- 15 If the test lamp does not light, a faulty earth lead is indicated.
- 16 Move the test lamp lead from the heater plug earth lead terminal to the interconnecting lead terminal. If the test lamp remains unlighted, a broken heater plug filament is indicated.
- 17 Check the remaining plugs in the same manner until the fault is located.
- 18 If the plugs are proved serviceable, check each terminal of the resistance in the same manner. If the resistance and the output lead are proved to be serviceable, check the input lead and starter switch.

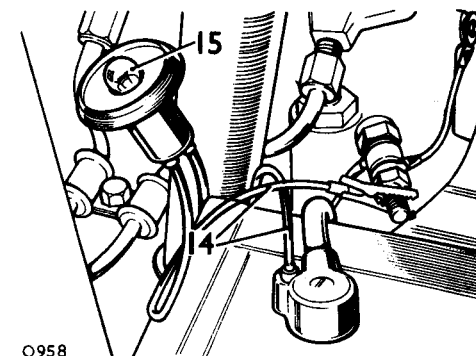

CONTACT BREAKER POINTS — 2¼ litre Petrol engines

Remove and refit 86.35.13

Removing

- 1 Remove the distributor cap and the rotor arm.
- 2 Ease the spring of the moving contact point clear of its nylon insulating block.
- 3 Detach the connector strip and the low tension and condenser leads from the spring.
- 4 Remove the screw and washers securing the fixed contact to the distributor base plate.
- 5 Remove the contact breaker points.

Refitting

- 6 Reverse instructions 2 to 5. Do not tighten the contact breaker securing screw at this stage.
- 7 Rotate the engine until the lobe of the rotor opens the points fully.
- 8 Adjust the position of the fixed cam to obtain a contact breaker gap of 0.014 to 0.016 in. (0.36 to 0.40 mm).
- 9 Tighten the securing screw.
- 10 Fit the rotor arm and distributor cap.

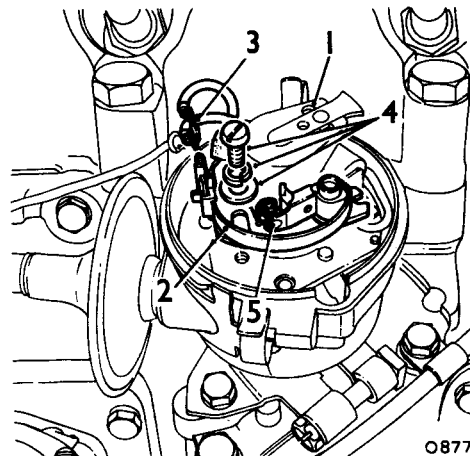

O877

CONTACT BREAKER POINTS — 2.6 litre Petrol engines

Remove and refit 86.35.13

Removing

- 1 Remove the distributor cap and rotor.
- 2 Remove the nut, insulation bush, low tension and capacitor leads.
- 3 Remove the lock screw, spring washer and plain washer.
- 4 Lift out the contact assembly and insulation bushes.

Refitting

- 5 Wipe the preservative from the new contact faces.
- 6 Engage the contact spring on to one of the insulation bushes.
- 7 Locate the contact assembly in position and retain with the lock screw, spring washer and plain washer.
- 8 Locate the capacitor lead, low tension lead and upper insulation bush in position and secure the nut.
- 9 Adjust the contact gap, see 96.35.14.

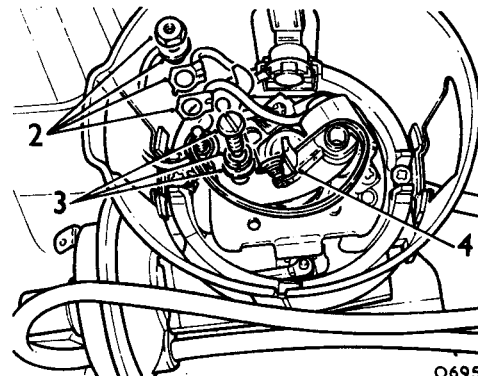

O695

DISTRIBUTOR — 2¼ litre and 2.6 litre Petrol engines

Contact gap—adjust 86.35.14

- 1 Remove the distributor cap and the rotor arm.
- 2 Rotate the crankshaft to position the contact heel on a cam peak.
- 3 If the contact gap is correct a 0.35 to 0.40 mm (0.014 to 0.016 in.) feeler gauge will just slide between the contacts.
- 4 When the contact gap is correct operations 6 to 8 may be ignored.
- 5 If correction is required slacken the lock screw.
- 6 Move the fixed contact about the pivot to adjust the gap. This may be facilitated by inserting a screwdriver between the slot as shown and twisting to position the fixed contact.
- 7 Tighten the lock screw.
- 8 Check that the correct gap has been maintained.

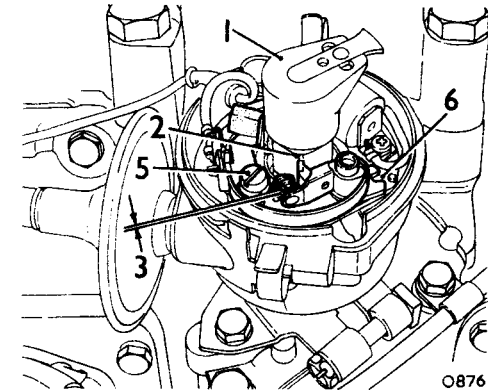

O876

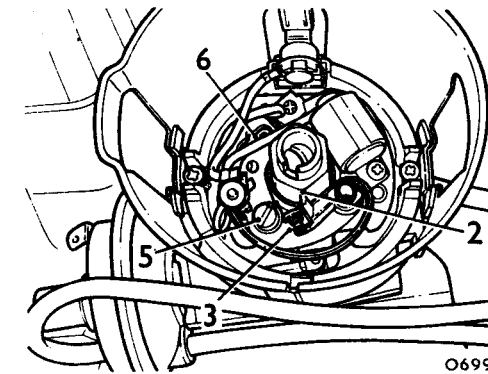

O699

DISTRIBUTOR

Ignition Timing—adjust 86.35.15

Static

- 1 Remove the distributor cap.
- 2 Check, and if necessary, adjust the contact breaker gap to 0,35 to 0,40 mm (0.014 to 0.016 in.) see 86.35.14.

NOTE: Land Rover petrol engines are produced with compression ratios of:

2½ litre	8:1 and 7:1
2.6 litre	7.8:1 and 7:1

The compression ratio is indicated by the commencing three digits of the engine number as follows:

Compression ratio	Engine numbers commence
8:1	901
7:1	904
7.8:1	941
7:1	944

Ignition settings are:

2½ litre engine

- 8:1 compression ratio T.D.C. with 90 octane fuel
- 7:1 compression ratio 3° B.T.D.C. when using 83 octane fuel

2.6 litre engine

- 7.8:1 compression ratio 2° A.T.D.C. when using 90 octane fuel
- 7:1 compression ratio 2° B.T.D.C. when using 83 octane fuel

- 3 The timing marks are carried on the crankshaft pulley and the timing pointer is mounted on the timing gear cover.

NOTE: Two types of timing marks are in use, either a multiple pointer with a single mark on the pulley, or single pointer with a scale of marks on the pulley.

The multiple pointer represents 6° B.T.D.C., 3° B.T.D.C., T.D.C. and 6° A.T.D.C. respectively.

The scale on the pulley represents 6° B.T.D.C., 3° B.T.D.C., T.D.C., 3° A.T.D.C. and 6° A.T.D.C.

- 4 Rotate the engine in direction of rotation until the appropriate timing mark is aligned with the pointer and the distributor rotor is at No. 1 cylinder firing position.

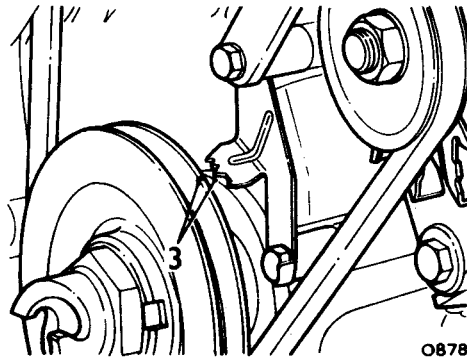

0878

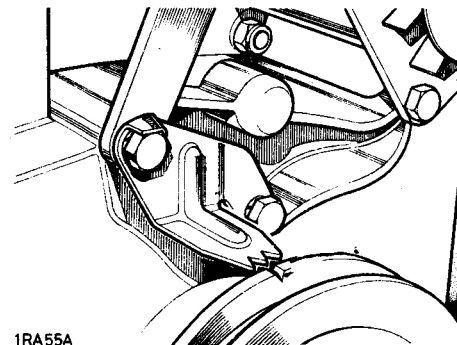

1RA55A

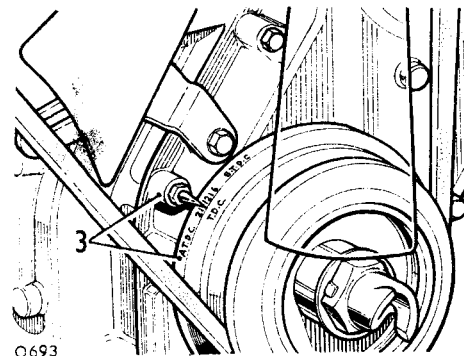

0693

- 5 Slacken the pinch bolt in base of distributor body and rotate the distributor in opposite direction to arrow on rotor arm until the contact breaker points are just opening with the cam follower on the leading side of the cam.

Re-tighten the pinch bolt.

- 6 Connect a 12 volt test lamp from the distributor l.t. terminal to earth.
- 7 Switch 'on' the ignition.
- 8 Rotate the engine two revolutions in the direction of rotation. The test lamp should light up as the timing pointer aligns with the appropriate mark on the crankshaft pulley.
- 9 Adjust as required by slackening the pinch bolt and turning the distributor bodily.

NOTE: If the distributor is the type with an external adjuster, this can be used for fine adjustment.

- 10 When satisfactory, secure the pinch bolt, remove the test lamp and leads and, refit the distributor cap.

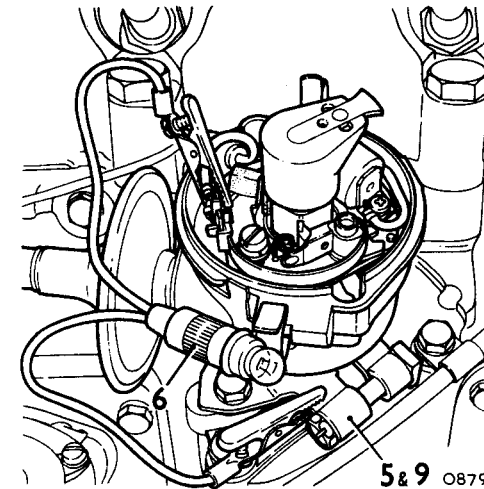

5 & 9 0879

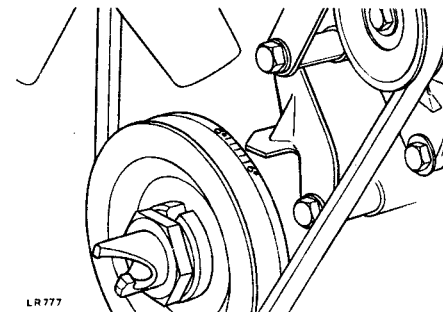

LR777

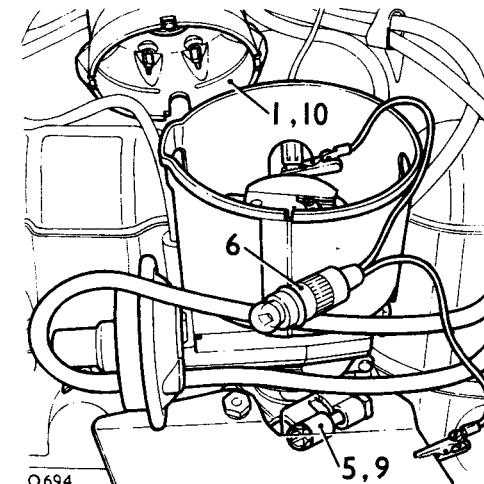

0694

5, 9

DISTRIBUTOR—2¼ litre Petrol engines

Remove and refit 86.35.20

Removing

- 1 Prop open the bonnet.
- 2 Remove the air cleaner, see 19.10.01.
- 3 Disconnect the vacuum pipe at the distributor.
- 4 Disconnect the leads at the sparking plugs.
- 5 Disconnect the h.t. and l.t. leads at the coil.
- 6 Remove the one bolt, spring washer and plain washer securing the clamp bracket to the pedestal.
- 7 Withdraw the distributor.

Refitting

- 8 Rotate the crankshaft until No. 1 piston is at TDC and the offset slot in the distributor drive gear is in the position shown.
- 9 Align the drive dog on the distributor with the offset slot in the drive gear and fit the distributor.
- 10 Remove the distributor cap; the distributor rotor arm should be in the No. 1 cylinder firing position and the distributor vacuum unit toward the rear of the engine.
- 11 Check, and if necessary, adjust the ignition timing, see 86.35.15.
- 12 Refit the air cleaner.

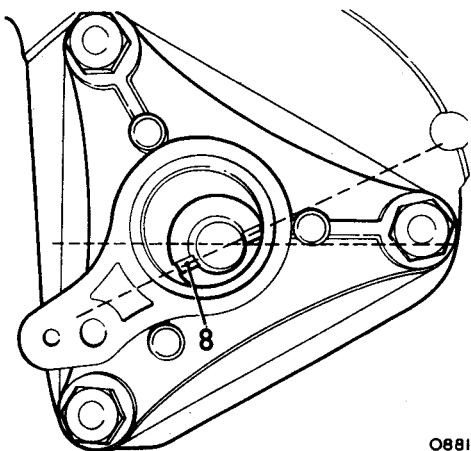
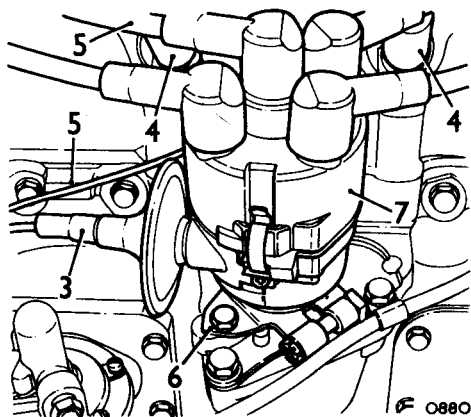

DISTRIBUTOR—2.6 litre Petrol engines

Remove and refit 86.35.20

Removing

- 1 Disconnect the vacuum pipe(s) at the distributor.
- 2 Disconnect the leads at the sparking plugs.
- 3 Disconnect the h.t. and l.t. leads at the distributor.
- 4 Remove the fixings and withdraw the distributor complete with heat shield from the drive housing.
- 5 If required, lift out the short drive shaft from the drive housing.

Refitting

- 6 If a new distributor is being fitted, check, and if necessary, adjust the contact breaker gap to 0,35 to 0,40 mm (0.014 to 0.016 in.).
- 7 If the distributor is the type with an external adjuster on the side of the body, set the knurled adjuster so that the fourth line on the calibrated slide is against the distributor body casing.
- 8 If removed, refit the short drive shaft to engage the offset drive.
- 9 Remove the side and top rocker covers.
- 10 Rotate the engine until the offset slot in the short drive shaft is positioned as illustrated with both valves closed on No. 1 (front) cylinder (that is, with No. 1 cylinder on firing stroke).
- 11 Align the drive dog on the distributor with the offset slot in the drive shaft and fit the distributor.
- 12 Remove the distributor cap; the distributor rotor arm should be in the No. 1 cylinder firing position and the distributor vacuum unit toward the front of the engine.
- 13 Check, and if necessary, adjust the ignition timing, see 86.35.15.
- 14 Refit the side and top rocker covers.

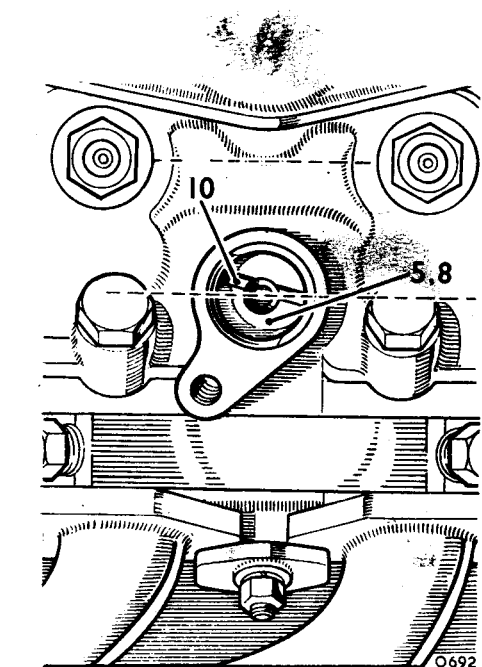
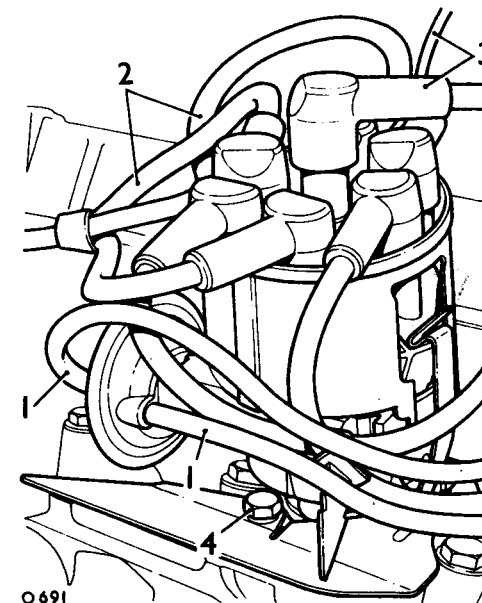

DISTRIBUTOR—2¼ litre Petrol engines

Overhaul

86.35.26

Dismantling

- 1 Remove the distributor from the vehicle, see 86.35.20.
- 2 Remove the distributor cap.
- 3 Withdraw the rotor arm.
- 4 Remove the screw, spring washer and plain washer and lift out the contact assembly.
- 5 Push the contact spring out of the terminal block and withdraw the terminal plate.
- 6 Withdraw the felt pad from the top of the camshaft.
- 7 Remove the capacitor screw. Manoeuvre the low tension lead grommet inwards towards the centre of the unit. Remove the capacitor and low tension lead connected together.
- 8 Remove two screws and anti-vibration washers. Withdraw the vacuum advance unit.
- 9 Remove the screw to release the expandable limb. Lift out the moving plate earth lead.
- 10 Using a small screwdriver push the expanded limb of the base plate inwards to release it from the body chamfered undercut. Lift out the plate assembly.
- 11 Tap out the drive gear pin. Remove the drive gear and thrust washer. Ensure that the shaft is burr-free and withdraw it.
- 12 Remove the distance collar.
- 13 Remove the control springs, exercising care not to distort the springs.

Reassembling

- 14 Lubricate the action plate, weight and cam assembly working surfaces with Rocol 'Moly pad'.
- 15 Fit the control springs, exercising care not to distort the springs.
- 16 Fit the distance collar.
- 17 Lubricate the shaft with Rocol 'Moly pad' and insert it into the body. Fit the thrust washer and drive gear. Secure with the drive gear pin.

- 18 Temporarily fit one screw and anti-vibration washer adjacent to one clip as shown. This is to facilitate operation 19 below.
- 19 Lubricate the moving plate pin with Rocol 'Moly pad'. Position the plate assembly so that the two downward facing prongs straddle the screw fitted at operation 18 above. Push the plate assembly downwards until it 'clicks' into the body chamfered undercut.
- 20 Position the moving plate earth lead tag. Fit the screw to expand the expandable limb.
- 21 Temporarily remove the screw and anti-vibration washer fitted at operation 18 above.
- 22 Lubricate the vacuum advance unit link hole with Rocol 'Moly pad'. Insert the vacuum advance unit so that the moving plate pin engages correctly in the link hole. Secure first with one screw and anti-vibration washer in the round hole. Secure secondly with one screw and anti-vibration washer in the elongated hole.
- 23 Thread the low tension lead outwards through the body hole. Manoeuvre the lead grommet into position. Position the capacitor and the moving plate earth lead tag. Secure with the capacitor screw.
- 24 Slide the moving contact from the post. Lightly grease the post with Shell Retinax A or equivalent. Fit the moving contact to the post.
- 25 Wipe the preservative from the new contact faces.
- 26 Clip the terminal plate to the contact spring.
- 27 Engage to contact spring in the terminal block.
- 28 Position the contact assembly and secure with the screw, spring washer and plain washer.
- 29 Lightly grease the cam with Shell Retinax A or equivalent.
- 30 Apply a few drops of engine oil to lubricate the cam spindle bearing.
- 31 Position the felt pad.
- 32 Fit the rotor arm.
- 33 Fit the distributor cap.
- 34 Refit the distributor to the vehicle.

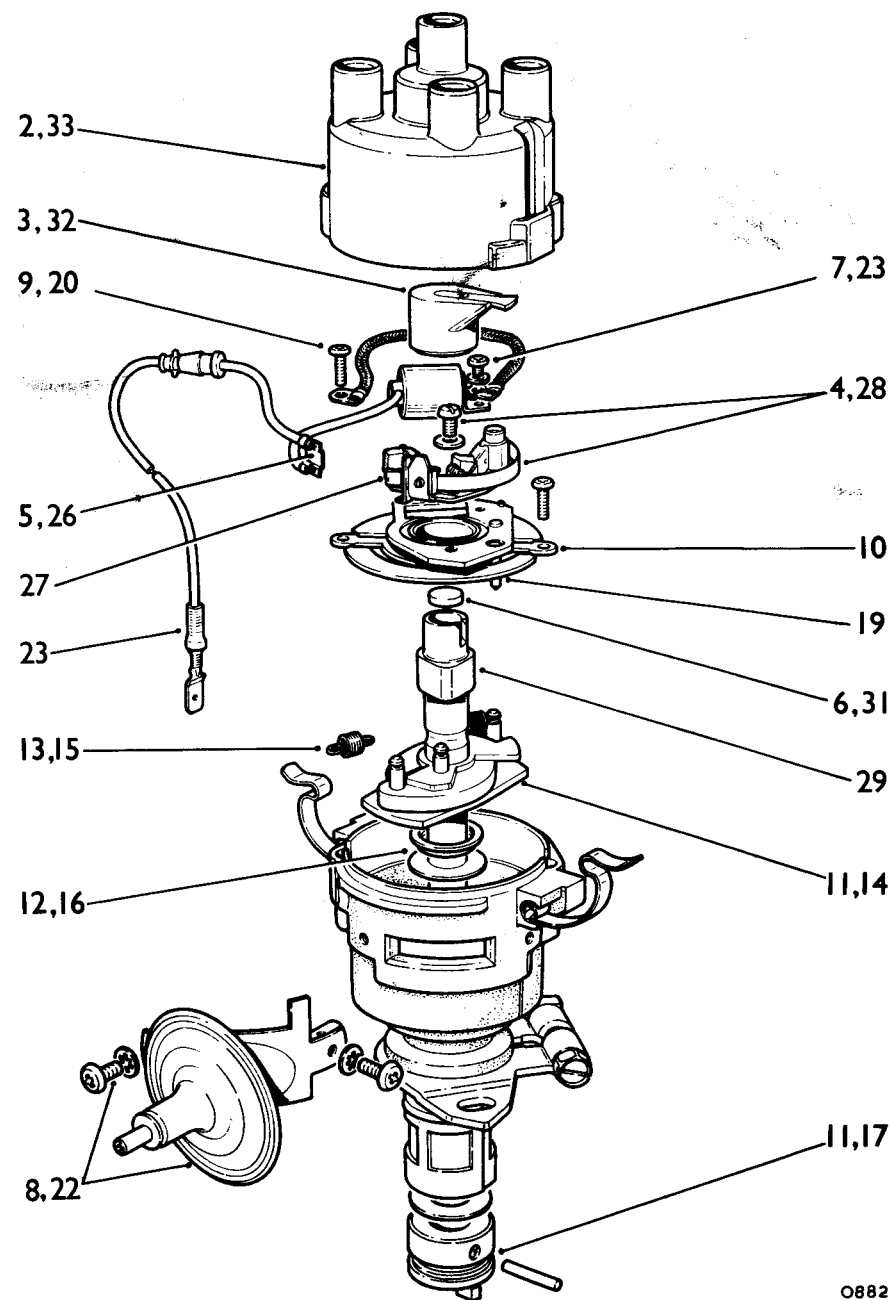

DISTRIBUTOR—2.6 litre Petrol engines

Overhaul

86.35.26

NOTE: There are three variants of distributor in use in order to comply with particular engine specifications. The variations can include a screen cover around the cap and/or an external adjuster on the side of the body, or neither. The following instructions apply to all variants.

Dismantling

- 1 Remove the distributor from the vehicle, see 86.35.20.
- 2 Remove the distributor cap.
- 3 Withdraw the rotor arm.
- 4 If the distributor is fitted with a screen cover, remove the two screws and washers and lift off the cover.
- 5 Disconnect the low tension and capacitor leads from the contact assembly.
- 6 Withdraw the low tension lead complete with terminal block.
- 7 Remove the contact assembly complete.
- 8 Remove the capacitor.
- 9 If the distributor is the type with only one connector tube on the vacuum unit, disconnect the spring between the vacuum unit and the base plate then remove the base plate assembly.
- 10 If the distributor is the type with two connector tubes on the vacuum unit, push the base plate downward and lift the vacuum unit arm from the pivot pin on the base plate and withdraw the base plate assembly.
- 11 Rotate the contact breaker moving plate clockwise to its full extent and withdraw it from the base plate.

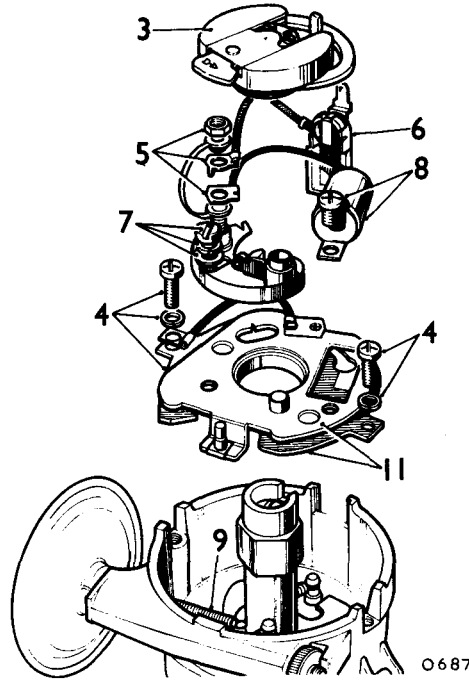

O687

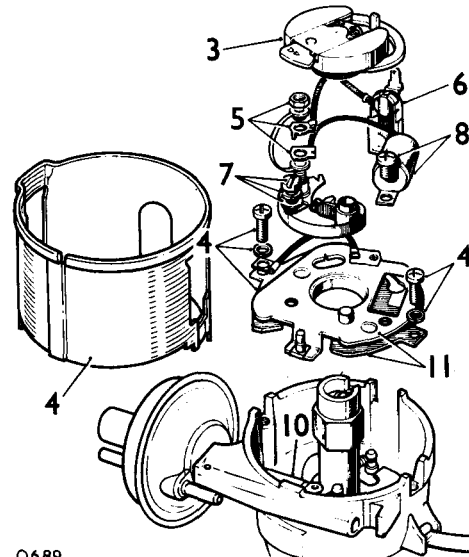

O689

- 12 If the distributor is the type with an external adjuster on the side of the body, remove the circlip, adjusting nut, coil spring and ratchet, and withdraw the vacuum unit.
- 13 If the distributor is the type that does not have an external adjuster, drive out the roll-pin from the distributor body and withdraw the vacuum unit.
- 14 Withdraw the springs from the centrifugal advance unit.
- 15 Remove the screw from inside the cam and withdraw the cam and cam foot, noting the position of the rotor arm slot in relation to the distributor driving dog for assembly purposes.
- 16 Remove the two weights.
- 17 Withdraw the 'O' ring seal and cork washer from the underside of the distributor.
- 18 Drive out the pin securing the driving dog and withdraw the dog and thrust washer.
- 19 Remove the action plate and shaft.
- 20 Withdraw the distance collar.
- 21 Remove the clamping plate and exhaust heat shield.

Reassembling

- 22 Lightly smear the shaft, weight pivots and working surfaces of the weights, action cams and action plate with Rocol 'Moly Pad'.
- 23 Ensure that the drive shaft rotates freely in the bush without side play, otherwise fit a new distributor complete.
- 24 Reassemble by reversing the removal procedure noting the following:
- 25 Do not overstretch the governor spring during refitting.
- 26 When fitted, adjust the contact points gap to 0,35 mm to 0,40 mm (0.014 to 0.016 in.).

NOTE: The rotor arm is a special speed limiter type.

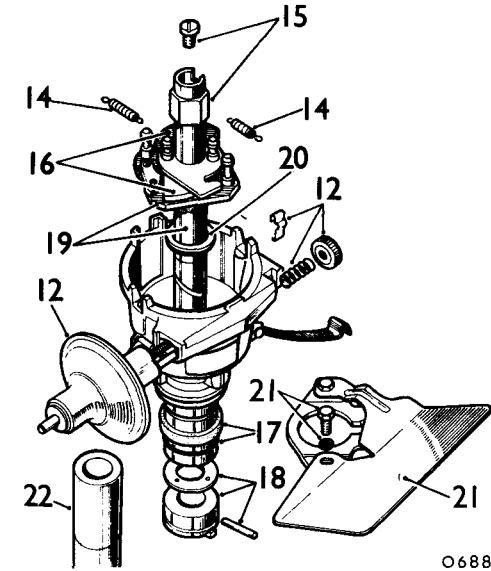

O688

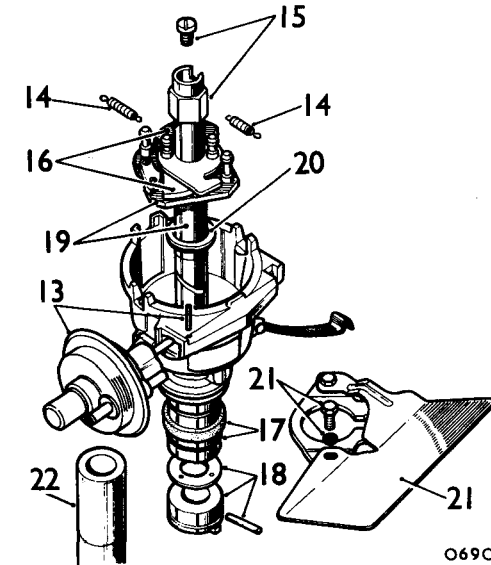

O690

IGNITION COIL

Remove and refit

86.35.32

Removing

- 1 Disconnect the battery.
- 2 Disconnect the high tension and low tension leads from the coil.
- 3 Remove the coil securing bolts.
- 4 Remove the coil.

Refitting

- 5 Reverse instructions 1 to 4.

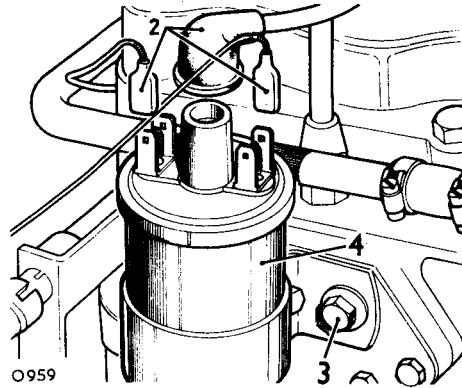

FRONT SIDE AND FLASHER LAMPS

Remove and refit
Front side lamp
Front flasher lamp

86.40.34
86.40.42

Removing

- 1 Disconnect the battery.
- 2 Remove the lamp lens.
- 3 If required, remove the bulb.
- 4 Disconnect the lamp leads at the snap connectors in the engine compartment.
- 5 Remove the lamp body.

Refitting

- 6 Reverse instructions 1 to 5.

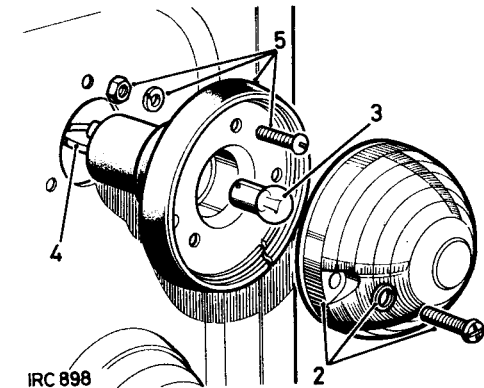

HEADLAMP ASSEMBLY

Remove and refit

86.40.02

Removing

- 1 Disconnect the battery.
- 2 Remove the headlamp bezel.
- 3 Remove the headlamp rim.
- 4 Disconnect the headlamp leads at the plug connector and withdraw the light unit.
- 5 Disconnect the spring from the headlamp shell.
- 6 Withdraw the headlamp shell by rotating it clear of the slotted locations.
- 7 Disconnect the headlamp leads at the snap connectors behind the radiator grille.
- 8 Remove the headlamp mounting shell.
- 9 Withdraw the gasket.

Refitting

- 10 Reverse instructions 1 to 9.
- 11 Check, and if necessary adjust, the headlamp, using suitable beam setting equipment.

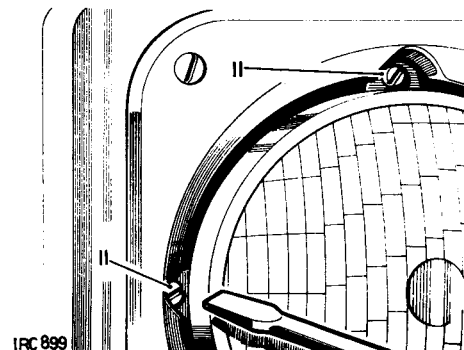
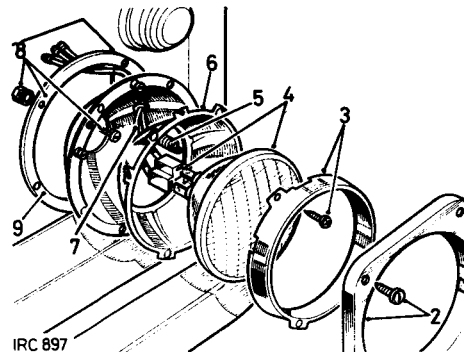

REAR FLASHER AND TAIL LAMPS

Remove and refit
Rear flasher lamp
Tail lamp

86.40.45
86.40.79

Removing

- 1 Disconnect the battery.
- 2 Remove the rear lamp cover plate from inside the vehicle.
- 3 Disconnect the lamp leads.
- 4 Remove the lamp lens.
- 5 If required, remove the bulb.
- 6 Remove the lamp body.
- 7 Withdraw the rubber mounting for the tail lamp.

Refitting

- 8 Reverse instructions 1 to 7.

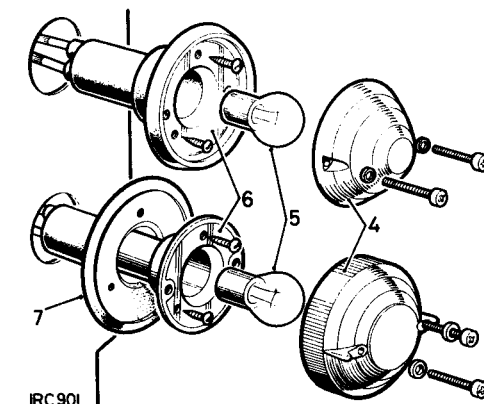
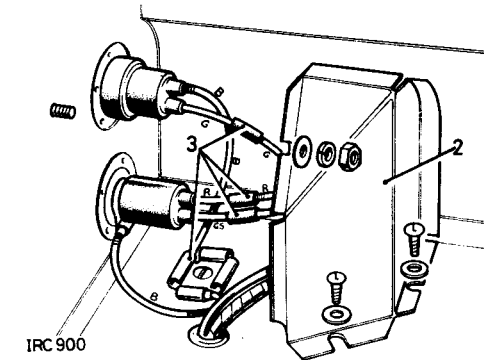

PANEL ILLUMINATION LAMP OR WARNING LAMP BULB

Remove and refit 86.45.31

Removing

- 1 Disconnect the battery.
- 2 Remove the two screws securing the instrument panels and ease the panel towards the steering wheel.
- 3 Withdraw the bulb holder and extract the bulb.

Refitting

- 4 Reverse instructions 1 to 3.

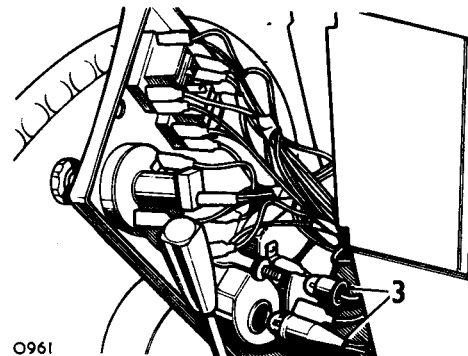
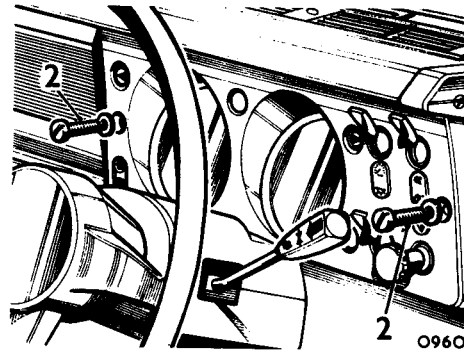

INSPECTION SOCKET

Remove and refit 86.45.33

Removing

- 1 Disconnect the battery.
- 2 Remove the two screws securing the instrument panel and ease the instrument panel towards the steering wheel.
- 3 Disconnect the electrical leads from the inspection socket.
- 4 Remove the screw lock rings, shock-proof washers and insulation tab.
- 5 Withdraw the sockets.

Refitting

- 6 Reverse instructions 1 to 5. Ensure that the insulation tab is located to prevent bridging of the electrical leads.

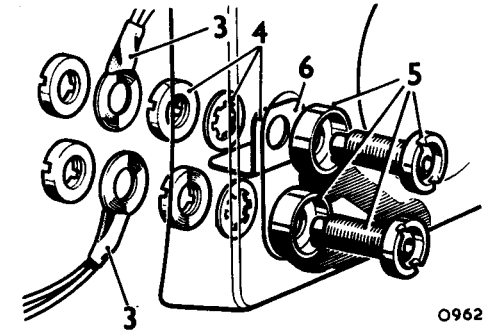

FLASHER UNIT

Remove and refit 86.55.11

Removing

- 1 Disconnect the battery.
- 2 Remove the two screws securing the instrument panel and ease the instrument panel towards the steering wheel.
- 3 Disconnect the electrical leads from the flasher unit.
- 4 Release the flasher unit from its retaining clip.

Refitting

- 5 Reverse instructions 1 to 4.
Lead Colours - Green to B terminal.
Lead Colours - Light Green to L terminal.

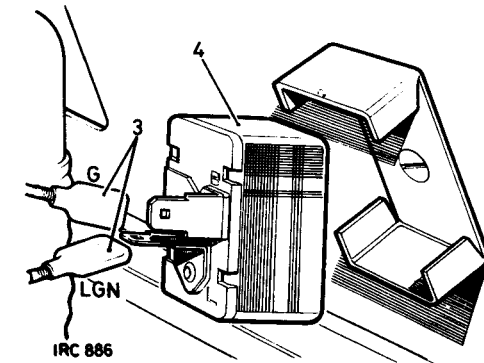

STARTER MOTOR

Remove and refit

86.60.01

Removing

- 1 Disconnect the battery.
- 2 Remove the exhaust manifold heat shield. (2¼ Petrol engine only)
- 3 Disconnect the electrical leads from the starter motor.
- 4 Remove the fixings securing the starter motor flange to the engine near mounting plate and bell housing.
- 5 Withdraw the starter motor. Note the earth cable fitting.

Refitting

- 6 Reverse instructions 1 to 5.

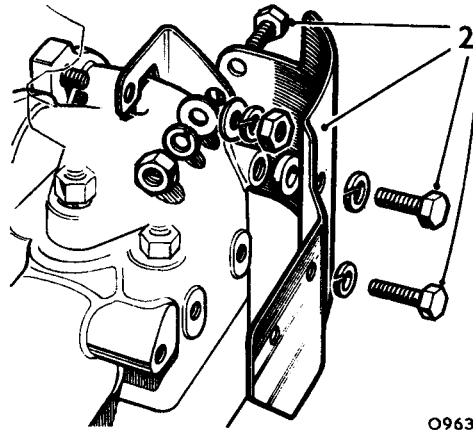

O963

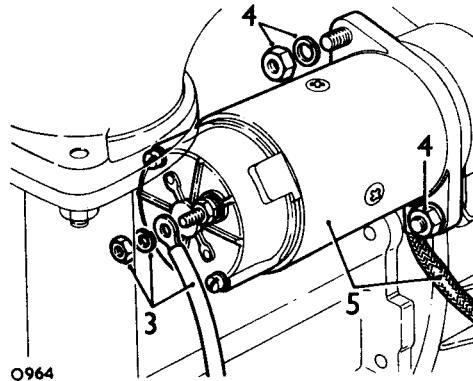

O964

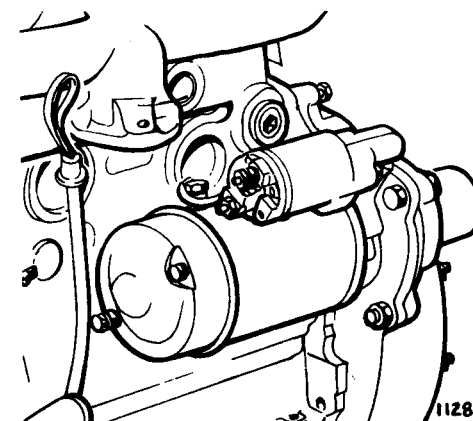

1128

STARTER SOLENOID – Petrol engines

Remove and refit

86.60.08

Removing

- 1 Disconnect the battery.
- 2 Disconnect the solenoid/battery lead.
- 3 Disconnect the solenoid/starter motor lead.
- 4 Disconnect the ignition, solenoid switch and engine harness leads from the solenoid.
- 5 Remove the two bolts and nuts securing the solenoid. To facilitate access to the solenoid it may be found advantageous to remove the air cleaner (2½ litre engines) or the battery (2.6 litre engines).
- 6 Remove the solenoid.

Refitting

- 7 Reverse instructions 1 to 6.

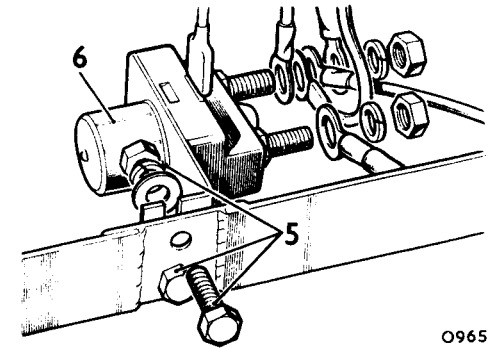

O965

STARTER MOTOR – Petrol engines

Overhaul

86.60.13

Dismantling

- 1 Remove the starter motor. See 86.60.08.
- 2 Remove the through bolts.
- 3 Withdraw the commutator end cover from the yoke, disengage the field brushes from the brush box moulding, and remove the end cover.
- 4 Withdraw the yoke from the armature and drive end assembly.
- 5 Using a suitable clamp, clamp the end collar and compress the main spring.
- 6 Remove the circlip from the armature shaft.
- 7 Remove the clamp.
- 8 Withdraw the end collar, main spring, washer, screwed sleeve and pinion collar, pinion retaining spring and spring retaining sleeve.

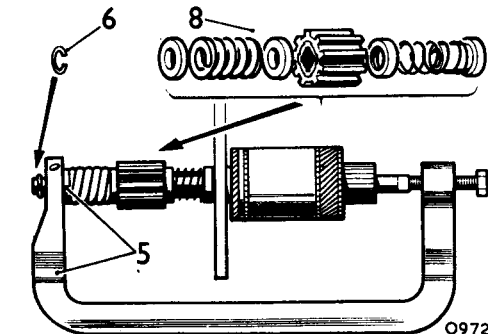

O972

continued

Inspection**Brushes**

- 9 Check that the brushes move freely in their holders. Any tendency to stick should be corrected by cleaning with a petrol moistened cloth, or in extreme cases by the light use of a fine file. Also ensure that the brush leads can move freely in the brush box slots. If a brush is damaged or worn so that it does not make good contact on the commutator, all the brushes must be renewed.
- 10 When brushes are worn to 9,5 mm (0.375 in.) length, new replacements must be fitted. The flexible connectors are soldered or crimped to terminal tags; two are connected to brush boxes, and two are connected to the free ends of the field coils. These flexible connectors must be removed by unsoldering, and the flexible connectors of the new brushes secured in their places by soldering. The new brushes, being pre-formed, 'bedding' to the commutator is unnecessary.

Commutator end bracket

- 11 Check the insulation of the brush springs by connecting a 110-volt a.c., 15-watt test lamp between a clean part of the commutator end cover and each of the springs in turn; the lamp will light if the insulation is not satisfactory.

Commutator

- 12 Clean the commutator with a petrol-moistened cloth. If necessary, rotate the armature and, using fine glass-cloth, remove pits and burned spots from commutator; remove abrasive dust with a dry air blast. If the commutator is badly worn, mount in a lathe, and, using a very sharp tool, take light cut, taking care not to remove more metal than is necessary. The insulators between the commutator segments must not be undercut.

Armature

- 13 If the armature is damaged, i.e. 'lifted' conductors, or distorted shaft, a new replacement must be fitted. Never attempt to machine the armature core, or 'true' a distorted armature shaft.

Insulation and continuity checks

If inspection of the armature and field coils of the starter motor do not reveal any faults, it is recommended that the following checks are carried out.

Armature insulation

- 14 Attach an ohm meter or a 110-volt AC test lamp in series with a 110-volt supply.
- 15 With two probes attached to the leads check the armature insulation by touching each commutator segment in turn with the other probe attached to the armature shaft.
- 16 The test lamp should not light up, or if an ohm meter is used, a high reading should be recorded. Should this not be the case, the armature insulation is faulty and a new replacement armature should be fitted.

Armature continuity

- 17 Indication of an open circuited armature winding will be given by burned commutator segments, this can be confirmed by substitution.

Field coil continuity

- 18 Check by connecting a 12-volt battery-operated test lamp between either of the brushes and a clean part of the yoke. The lamp should light.

Field coil insulation:

- 19 Before being able to check the insulation between the field coils and yoke, it will first be necessary to disconnect the earthed end of the winding from the yoke. Before disconnecting the winding (refer to the heading 'Renewing the field coils'), determine whether it is justified. Consider the results of

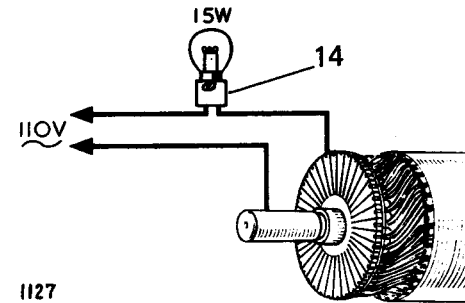

1127

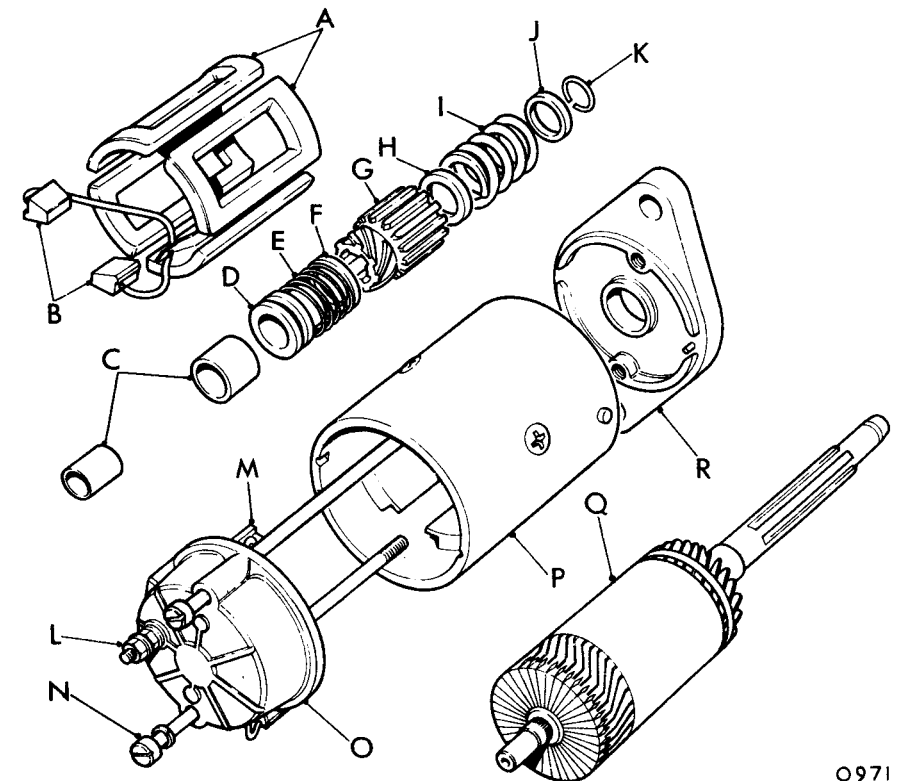
**KEY**

A	Field coils
B	Field coil brushes
C	Bearing brushes
D	Spring retaining sleeve
E	Spring
F	Pinion collar
G	Pinion and screwed sleeve
H	Washer
I	Main spring
J	End Collar
K	Circlip
L	Field coil input terminal
M	Earth brushes
N	Commutator end cover and brush box assembly
O	Yoke
P	Armature
Q	Drive end bracket

continued

the light running and lock torque tests, or alternatively consider the fault symptoms. If the speed and torque were low, and the current consumption high, or the fault symptom was low cranking speed, faulty field winding insulation could be the cause and this interpretation of the starting motor performance would justify disconnecting the earthed end of the field winding to enable a positive check to be carried out.

- 20 The field winding insulation can be checked (after disconnecting the winding at the yoke) by connecting a 110-volt a.c. 15-watt test lamp between the disconnected end of the winding and a clean part of the yoke. The lamp should not light. Ensure that neither of the brushes, or bare parts of their flexibles, contact the yoke during the test.

NOTE: Due to the very low resistance of the field coil conductors, the presence of a short-circuit between the field coil windings can only be determined by specialised equipment. If the results of all previous testing has been satisfactory, short-circuited field coil windings could be the cause of the fault and the field coil assembly should now be further proved by substitution.

Renewing the field coils

- 21 Disconnect the end of the field winding where it is riveted to the yoke. To do this, file away the riveted-over end of the connecting-eyelet securing rivet, sufficient to enable the rivet to be tapped out of the yoke. Remove the four pole-shoe screws with a wheel-operated or power-operated screwdriver and withdraw the field coil assembly from the yoke. Wipe clean the inside of the yoke, and the insulating pieces through which the through bolts locate.
- 22 Loosely fit the new field coil assembly (with pole-shoes) into the yoke, with the threads of the pole-shoe fixing screws only partially engaged. The through bolt insulating pieces should now be assembled into the yoke, by sliding the shoulders of the insulating

pieces between the field coils and the yoke, in a position 180° apart and 90° each side of the field coil brush connection point (refer Fig. 4). Now tighten the pole-shoe screws progressively to a torque of 30 lbf ft (2.64 kgf m). Finally, make a good earth connection between the end of the field winding and the yoke.

Bearings

- 23 If the bearings in the commutator end cover and the drive-end bracket are worn sufficiently to allow excessive side-play of the armature shaft, the bearing bush must be renewed.

NOTE: New bushes must be immersed in new engine oil for 24 hours or in oil heated to 100° C. (212° F) for two hours prior to fitting. The bushes must not be reamed after fitting.

Reassembling

- 24 Reverse instructions 5 to 8, use a suitable piece of steel tube with a tapered end to fit the circlip to the armature shaft.
- 25 Fit the starter yoke to the armature assembly, ensuring that the location peg on the drive end bracket fits into the recess on the yoke.
- 26 Locate the field coil brushes into the brush box.
- 27 Fit the commutator end cover, ensuring that the earth brush leads do not become trapped between the end cover and the yoke.
- 28 Fit the two through bolts and spring washers. Torque 1,0 kgf. m. (8 lbf. ft.).
- 29 Fit the insulating washer, plain washer, spring washer and nut to the field coil input post.
- 30 Refit the starter motor.

DATA

Starter (2M100)

Brush spring tension	36 oz. (1,02 kg.)
Minimum brush length	0.375 in. (9,0 mm.)
Minimum commutator thickness	0.140 in. (3,5 mm.)
Lock torque	14.4 lb. ft. (2,02 kg. m.) with 463 amps.
Torque at 1,000 r.p.m.	7.3 lb. ft. (1,02 kg. m.) with 300 amps.
Light running current	40 amp at 6,000 r.p.m. (approx.)
Maximum armature end-float	0.010 in. (0,25 mm.)

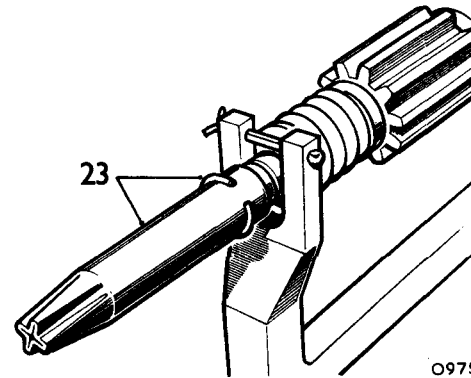

O975

STARTER MOTOR—2¼ litre Diesel engines

Overhaul

86.60.13

Dismantling

- 1 Remove the starter motor. 86.60.08.
- 2 Remove the link connecting the solenoid to the starter motor yoke terminal.
- 3 Remove the solenoid from the drive end bracket.
- 4 Withdraw the gasket.
- 5 Grasp the solenoid plunger and lift the front end to release it from the top of the drive engagement lever.
- 6 Remove the block shaped sealing grommet wedged between the solenoid fixing part of the drive end bracket and the yoke.
- 7 Remove the commutator-end sealing cover.
- 8 Withdraw the seals.
- 9 Withdraw the field coil brushes from their holders.
- 10 Remove the commutator end bracket from the starter yoke.
- 11 Withdraw the yoke and field coil assembly.
- 12 Withdraw the sealing ring.
- 13 Remove the eccentric pin.
- 14 Withdraw the armature.
- 15 Withdraw the engagement lever.
- 16 Withdraw the seals for the through bolts.
- 17 Using a suitable tube, remove the collar and jump ring from the armature shaft.
- 18 Withdraw the drive assembly and intermediate bracket.
- 19 Remove the brake ring, steel washer and tufnol washer from the commutator end bracket.

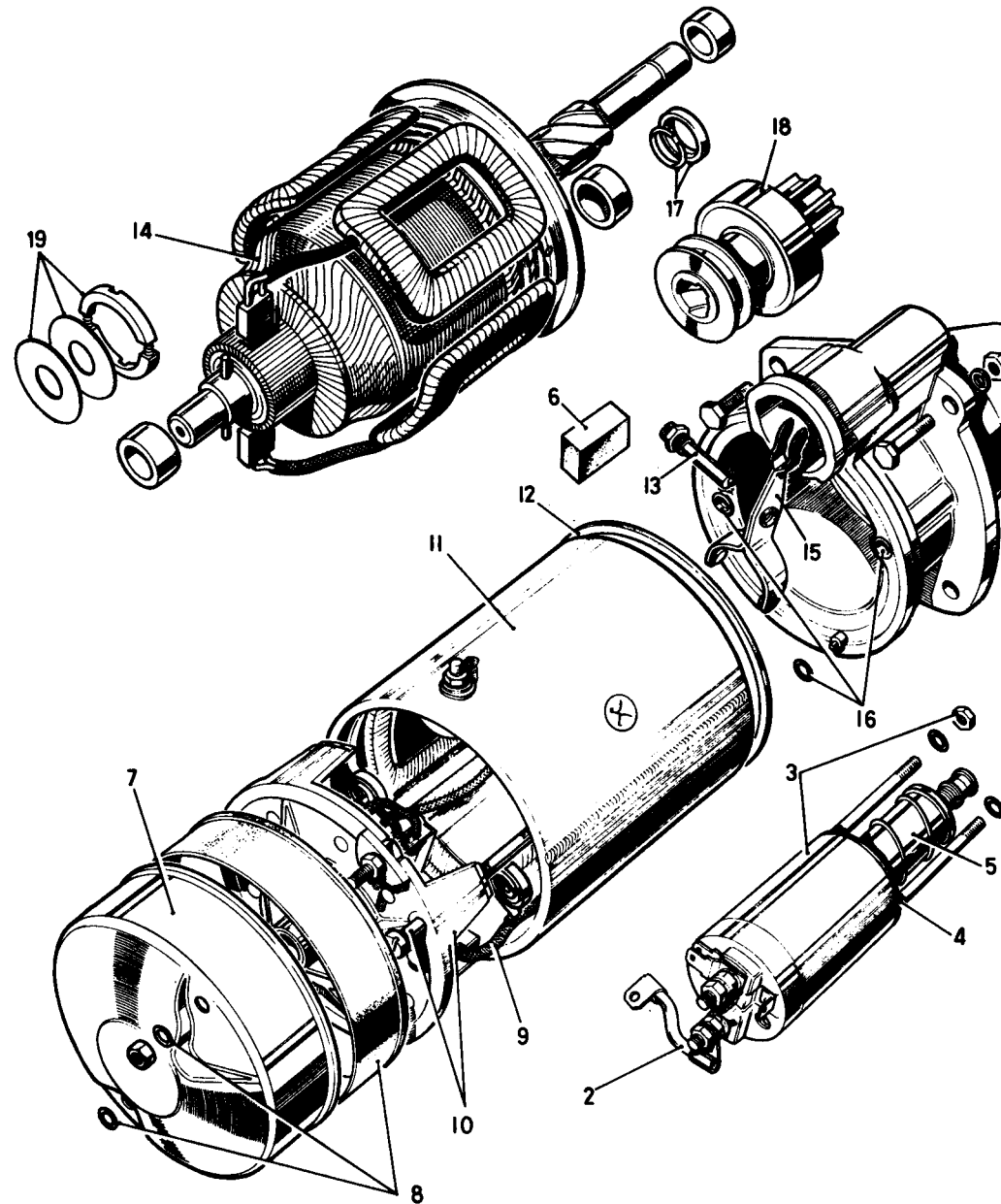

continued

Inspecting

Clutch

- 20 Check that the clutch gives instantaneous take up of the drive in one direction and rotates easily and smoothly in the other direction.
- 21 Ensure that the clutch is free to move round and along the shaft splines without any tendency to bind.

NOTE: The roller clutch drive is sealed in a rolled steel outer cover and cannot be dismantled.

- 22 Lubricate all clutch moving parts with Shell SB 2628 grease for cold and temperate climates or Shell Retinax 'A' for hot climates.

Brushes

- 23 Check that the brushes move freely in their holders while holding back the brush springs. Rectify sticking brushes by wiping with a petrol moistened cloth.
- 24 Fit new brushes if they are damaged or worn to approximately 8 mm (0.312 in.) in length.

NOTE: New brushes are pre-formed and do not require bedding to the commutator.

- 25 Check the brush box insulation by connecting a 110V a.c. 15W test lamp between a clean part of the bracket and each of the two insulated brush-boxes in turn. If the lamp lights, renew the commutator end bracket assembly.
- 26 Using a spring balance, check the brush spring pressure. With new brushes assembled in the bracket and the brushes contacting the commutator, the pressure should be approximately 1,2 kgf (42 ozf.). If the pressure is low, fit new springs.
- 27 Check the commutator. If cleaning only is necessary, use very fine glass paper or emery cloth, and then wipe the commutator surface with a petrol moistened cloth. If necessary, the commutator may be machined, providing a finished surface can be obtained without reducing the diameter below 38,0 mm (1.500 in.), otherwise a new armature must be fitted.

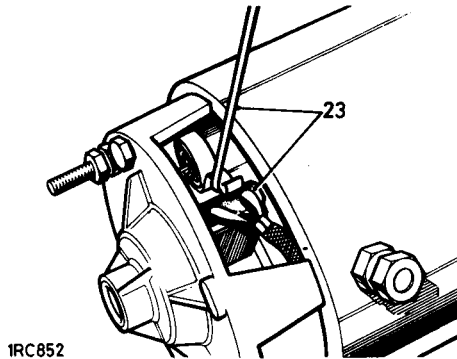

1RC852

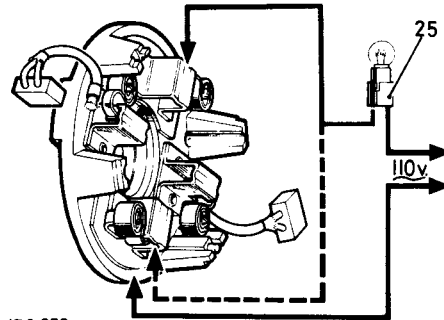

1RC 853

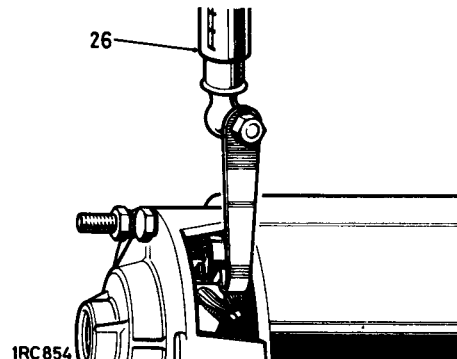

1RC854

Armature insulation

- 28 Connect a 110V a.c. 15W test lamp between any one of the commutator segments and the shaft.
- 29 The lamp should not light, if it does light, fit a new armature.

Field coil insulation

- 30 Connect a 110V a.c. 15W test lamp between the yoke terminal and the yoke.
- 31 Ensure that the brushes are not touching the yoke during the test.
- 32 The lamp should not light, if it does light, fit a new field coil assembly.

Field coil continuity

- 33 Connect a 110V a.c. 15W test lamp between the two field coil brushes.
- 34 The lamp should light, if it does not light, fit a new field coil assembly.

Solenoid

- 35 Disconnect all cables from the solenoid terminals and connectors.
- 36 Connect a 12V battery and a 12V 60W test lamp between the solenoid main terminals. The lamp should not light, if it does light, fit new solenoid contacts or a new solenoid complete.
- 37 Leave the test lamp connected and, using the same 12V battery supply, energise the solenoid by connecting 12V between the small solenoid operating 'Lucar' terminal blade and a good earth point on the solenoid body.
- 38 The solenoid should be heard to operate and the test lamp should light with full brilliance, otherwise fit new solenoid contacts or a new solenoid complete.

Assembling

- 39 Reverse the dismantling procedure, noting the following.
- 40 Fit the drive engagement lever with the flatter edge towards the solenoid.
- 41 Leave the locknut for the eccentric pivot pin loose until the drive pinion setting has been adjusted.
- 42 Fit new seals and gasket.

continued

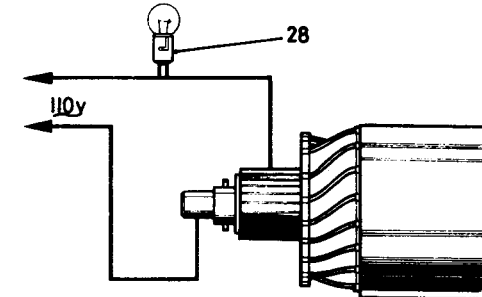

1RC 855

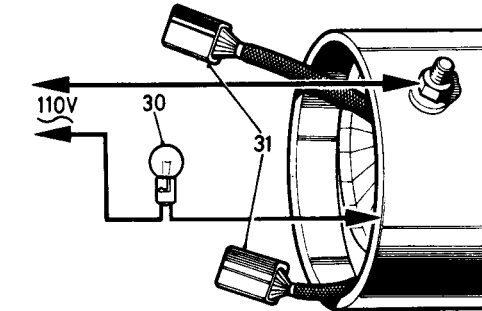

1RC856

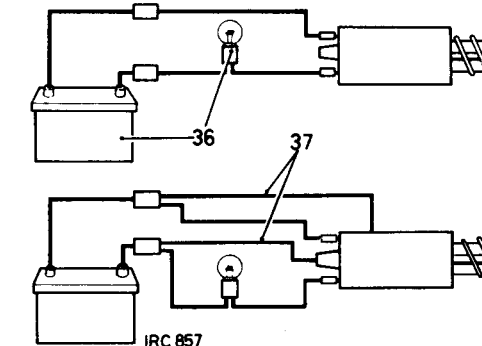

1RC 857

- 43 Torque tighten the solenoid fixing nuts 0,62 kgf. m (5.5 lbf. ft.).
 44 Torque tighten the solenoid outer terminal nuts 0,41 kgf. m (3.0 lbf. ft.).
 45 Torque tighten the yoke terminal outer nut 0,2 kgf. m (1.5 lbf. ft.).
 46 Torque tighten the starter through bolts 1,1 kgf. m (8.0 lbf. ft.).
 47 Torque tighten the earth stud nut 0,82 kgf. m (6.0 lbf. ft.).

Setting drive pinion

- 48 If fitted, remove the link connecting the solenoid to the starter motor yoke terminal.
 49 Connect the solenoid terminal 'STA' to the starter yoke case (not to the starter terminals).
 50 Connect a 6V supply between the solenoid-operating 'Lucar' terminal and the starter yoke case (not the starter terminals).
 51 With the solenoid energised and the drive assembly in the engaged position, hold the pinion pressed lightly towards the armature to take up any free play in the engagement linkage.
 52 Measure the clearance between the pinion and the thrust collar on the armature shaft. The correct clearance is 0,12 mm to 0,38 mm (0.005 in. to 0.015 in.).
 53 If necessary, adjust the clearance by rotating the eccentric pivot pin.
 54 Remove the connections from the solenoid and the starter yoke case.
 55 Apply sealing compound to the threads of the eccentric pivot pin and secure the locknut. Torque 2.2 kgf. m (16.0 lbf. ft.).
 56 Reverse 1 and 2.

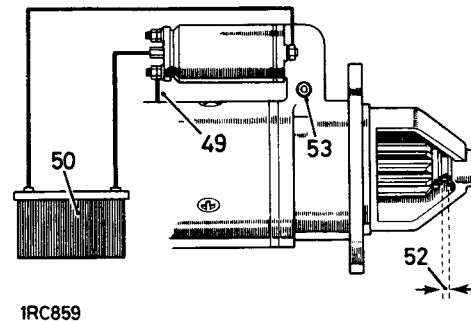

1RC859

DATA

Starter motor

Make/type	Lucas M45G Pre-engaged, oil and waterproof
Brush spring tension	1,2 kg (42 oz.)
Brush minimum length	8,0 mm (0.312 in.)

IGNITION/STARTER SWITCH – (Petrol engines) HEATER/STARTER SWITCH – (Diesel engines)

Remove and refit 86.65.02

Removing

- 1 Disconnect the battery.
- 2 Remove the steering column shroud.
- 3 Remove the lower fascia 76.46.05.
- 4 Disconnect the electrical leads from the ignition/starter switch.
- 5 Remove the two screws securing the switch to the steering column lock assembly.
- 6 Withdraw the ignition/starter switch.

Refitting

- 7 Reverse instructions 1 to 6.

Connect switch leads as follows:

Diesel engines

- Brown/red lead to terminal 1.
- White/red lead to terminal 2.
- White lead to terminal 3.
- Brown leads to terminal 4.

Petrol engines

- Brown leads to terminal 1.
- White leads to terminal 2.
- White/red lead to terminal 3.

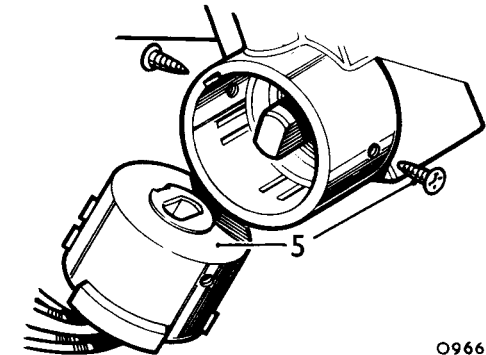

O966

LIGHTING SWITCH

Remove and refit

86.65.10

Removing

- 1 Disconnect the battery.
- 2 Unscrew and remove the locking ring and wave washer from the lighting switch.
- 3 Remove the two screws securing the instrument panel and ease the panel towards the steering wheel.
- 4 Disconnect the electrical leads from the rear of the lighting switch.
- 5 Withdraw the lighting switch.

Refitting

- 6 Reverse instructions 1 to 5.

Connect leads as follows:

- Red/black leads to terminal 1.
- Red lead to terminal 7.
- Brown lead to terminal 4.
- Blue lead to terminal 8.

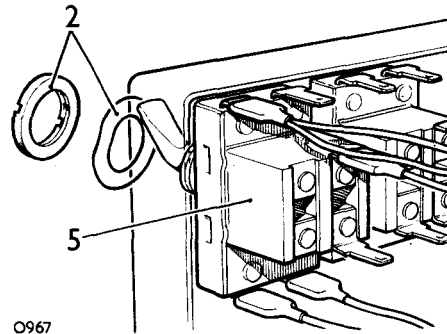

WINDSCREEN WIPER SWITCH

Remove and refit

86.65.38

Removing

- 1 Disconnect the battery.
- 2 Depress the plunger retaining the wiper switch knob and withdraw the knob.
- 3 Unscrew and remove the lock ring and wave washer from the wiper switch.
- 4 Remove the screws securing the instrument panel and ease the panel towards the steering wheel.
- 5 Disconnect the electrical leads from the rear of the wiper switch.
- 6 Withdraw the wiper switch.

Refitting

- 7 Reverse instructions 1 to 7.

Connect leads as follows:

Petrol engines

- Light green/black to terminal 3.
- Red/light green to terminal 2.
- Green to terminal 4.
- Brown/light green to terminal 1.

Diesel engines

- Brown/light green to terminal 3.
- Red/light green to terminal 2.
- Green to terminal 4.
- Light green/black to unmarked terminal

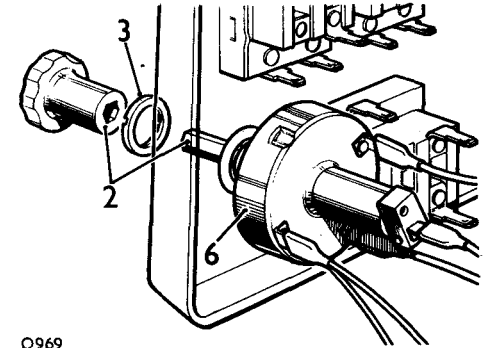

PANEL LIGHT SWITCH

Remove and refit

86.65.12

Removing

- 1 Disconnect the battery.
- 2 Unscrew and remove the locking ring and wave washer from the panel light switch.
- 3 Remove the screws securing the instrument panel and ease the panel towards the steering wheel.
- 4 Disconnect the electrical leads from the rear of the panel light switch.
- 5 Withdraw the panel light switch.

Refitting

- 6 Reverse instructions 1 to 5.

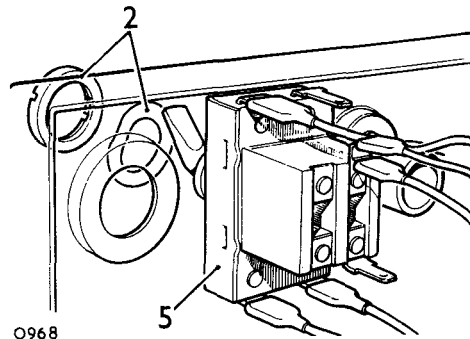

STOP LIGHT SWITCH

Remove and refit

86.65.51

Non-servo models instructions 1 to 7

Removing

- 1 Disconnect the battery.
- 2 Remove the switch protection plate from the brake pedal bracket.
- 3 Disconnect the electrical leads from the switch.
- 4 Depress the brake pedal and remove the end stop from the switch and withdraw the switch from the mounting bracket.

Refitting

- 5 Reverse instructions 1 to 4.
- 6 Check the dimension between the lower edge of the brake pedal and the floor. The correct dimension is 158 mm (6.250 in.).
- 7 If necessary, set the brake pedal adjuster to give the correct dimension.

Servo-assisted models instructions 8 to 12

Removing

- 8 Disconnect the battery.
- 9 Disconnect the leads from the stop lamp switch.
- 10 Release the locknut and unscrew the switch from the brake pedal bracket.

Refitting

- 11 Reverse instructions 8 to 10.
- 12 Check, and if necessary adjust, the stop lamp switch to operate at 19 to 25 mm (0.750 to 1.000 in.) of pedal movement.

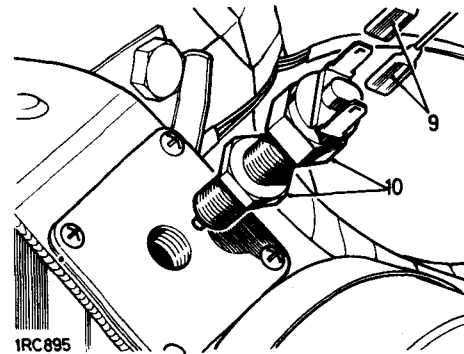
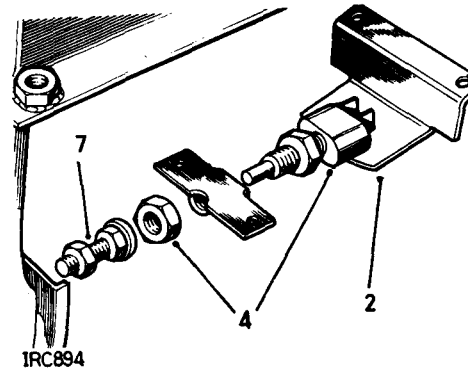
**CHOKE WARNING LIGHT SWITCH**

Remove and refit

86.65.53

Removing

- 1 Disconnect the battery.
- 2 Disconnect the electrical leads from the choke switch.
- 3 Release the clip securing the switch to the choke cable.
- 4 Remove the switch.

Refitting

- 5 Check that the choke inner cable is adjusted to provide a minimal clearance behind the knob when the knob is pushed in.
- 6 Check the switch to ensure that the spring loaded plunger projects and is free to move in the switch body.
- 7 Pull out the choke knob and locate the switch operating plunger in the centre hole in the sleeve of the choke outer cable; the two locating dowels engage in the outer holes.
- 8 Secure the switch in position and tighten the securing bolt and lock nut. Ensure the bolt is not overtightened to the extent where it will cause the plunger to jam.
- 9 Connect the switch leads.
- 10 Connect the battery.
- 11 Check switch and light operation.

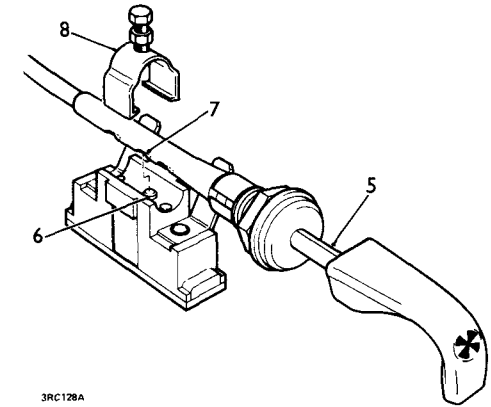

COMBINED DIRECTION INDICATOR, HEADLIGHT AND HORN SWITCH

Remove and refit 86.65.55

Removing

- 1 Disconnect the battery.
- 2 Remove the shroud from the steering column.
- 3 Remove the two screws securing the instrument panel and ease the panel towards the steering wheel.
- 4 Disconnect the switch harness block from the main harness socket.
- 5 Disconnect the single Lucas connector from the main harness to the switch.
- 6 Disconnect the headlamp dip lead from the fuse box.
- 7 Disconnect the lead to panel light switch.
- 8 Disconnect the lead to the voltage stabiliser.
- 9 Remove the screws securing the switch clip to the steering column.
- 10 Remove the switch.

Refitting

- 11 Reverse instructions 1 to 10.

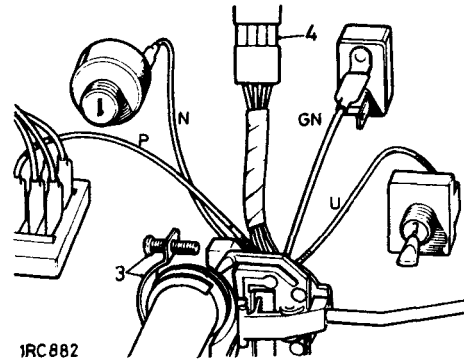

FUSE BOX

Remove and refit 86.70.01

Removing

- 1 Disconnect the battery.
- 2 Remove the steering column shroud.
- 3 Detach electrical connections from the fuse box terminals. Note the wiring colours and locations.
- 4 Remove the screws securing the fuse box.
- 5 Remove the fuse box.

Refitting

- 6 Reverse instructions 1 to 5.
- NOTE:** All fuses should be 35 amp.

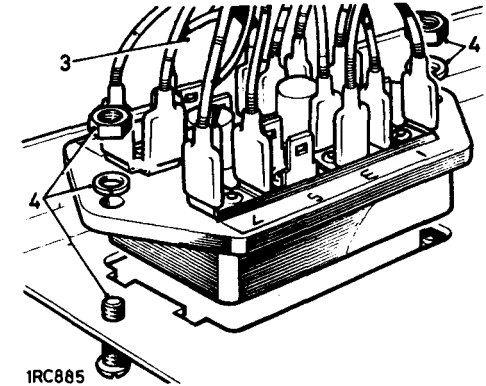

INSTRUMENT PANEL

Remove and refit

88.20.01

Removing

- 1 Disconnect the battery.
- 2 Remove the two screws securing the instrument panel to the fascia.
- 3 Withdraw the instrument panel towards the steering wheel.
- 4 Depress the clip on the speedometer cable and withdraw the cable from the speedometer.
- 5 Withdraw the bulb holders from the combined gauge cluster (2) and the speedometer (4).
- 6 Disconnect the terminals from the fuel and temperature gauges.
- 7 Disconnect the terminals from the voltage stabilizer.
- 8 Withdraw the bulb holders from the left and right hand turn indicators.
- 9 Disconnect the terminals from the lighting switch, panel light switch, wiper/washer and heater switch.
- 10 Disconnect the terminals from the inspection lamp socket (two circular slotted nuts).
- 11 Withdraw the instrument panel from the vehicle.

Refitting

- 12 Slide the instrument panel into position between the steering wheel and the fascia.
- 13 Connect all terminals. Refer to illustration for locations and colour code.
- 14 Insert the bulb holders.
- 15 Connect the speedometer cable.
- 16 Fit the instrument panel to the fascia and secure in position with two screws.
- 17 Connect the battery.

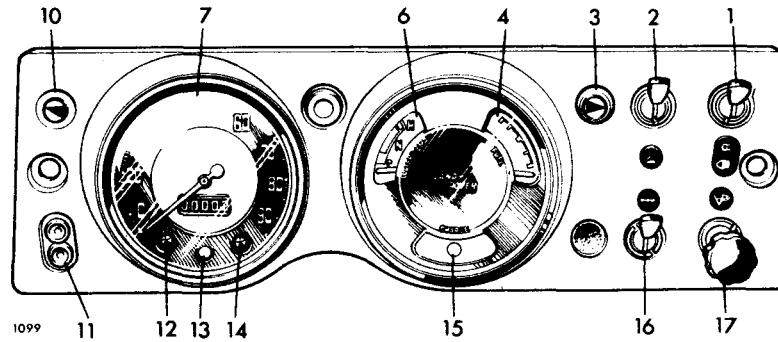

Key to instrument panel

- 1 Side lamp/headlamp switch
- 2 Panel light switch
- 3 Direction indicator light – right hand
- 4 Fuel gauge
- 5 Group instrument light
- 6 Water temperature gauge
- 7 Speedometer
- 8 Speedometer light
- 9 Voltage stabiliser
- 10 Direction indicator light – left hand
- 11 Inspection lamp socket
- 12 Oil pressure light
- 13 Main beam indicator light
- 14 Choke indicator light
- 15 Ignition light
- 16 Heater switch
- 17 Wiper/washer switch

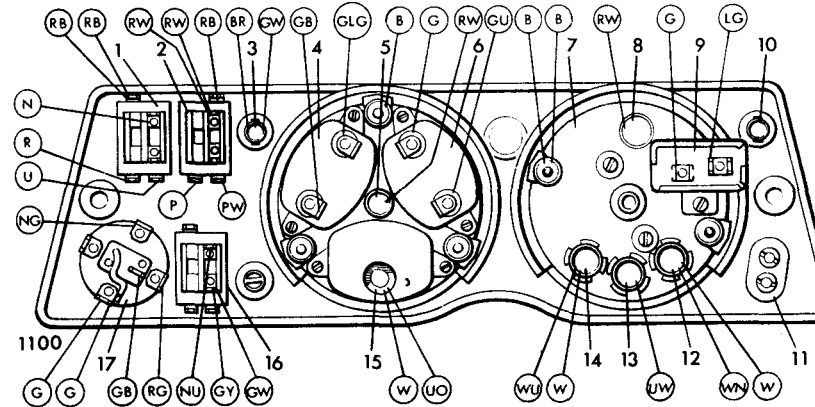

KEY TO CABLE COLOURS

B	Black	G	Green	R	Red
U	Blue	O	Orange	W	White
N	Brown	P	Purple	L	Light
Y	Yellow				

VOLTAGE STABILIZER

Remove and refit

88.20.26

Removing

- 1 Disconnect the battery.
- 2 Remove the two screws securing the instrument panel to the fascia.
- 3 Withdraw the instrument panel towards the steering wheel.
- 4 Disconnect the terminals from the voltage stabilizer.
- 5 Remove the screw securing the voltage stabilizer to the speedometer.
- 6 Remove the voltage stabilizer.

Refitting

- 7 Fit the voltage stabilizer to the speedometer.
- 8 Connect the voltage stabilizer terminals.
Green lead to terminal 'B'.
Light green lead to terminal 'I'.
- 9 Fit the instrument panel to the fascia.
- 10 Connect the battery.

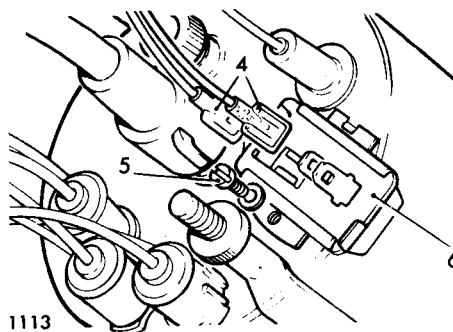

1113

OIL PRESSURE WARNING SWITCH

Remove and refit

88.25.08

2.6 litre engine, instructions 1 and 3 to 6.
2½ litre engine, instructions 2 to 6.

Removing

- 1 2.6 litre engine. Locate the switch at the lower end of the rocker oil feed pipe, rear LH side of the engine.
- 2 2½ litre engine. Locate the switch at the oil filter, RH side of the engine.
- 3 Disconnect the electrical lead.
- 4 Unscrew the switch.
- 5 Withdraw the joint washer.

Refitting

- 6 Reverse 1 to 5 as applicable.

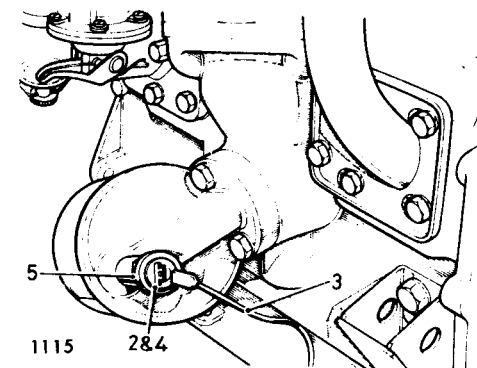

1115

284

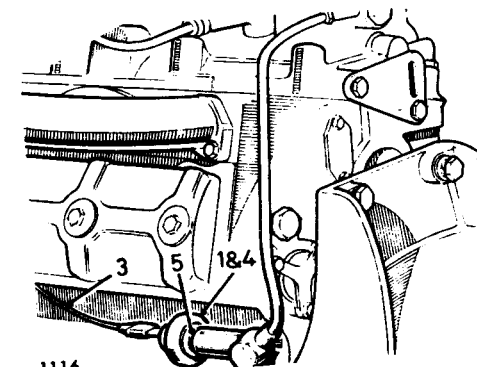

1116

COOLANT TEMPERATURE GAUGE

Remove and refit

88.25.14

Removing

- 1 Disconnect the battery.
- 2 Remove the two screws securing the instrument panel to the fascia.
- 3 Withdraw the instrument panel.
- 4 Withdraw the bulb holders (2) from the grouped gauge assembly.
- 5 Disconnect the terminals from the fuel gauge and temperature gauge.
- 6 Remove the three knurled nuts securing the grouped gauge assembly to the instrument panel.
- 7 Withdraw the three clamp brackets. Note the earth connection eyelet fitted to the top stud.
- 8 Withdraw the grouped instrument assembly.
- 9 Remove the two screws securing the temperature gauge and withdraw the temperature gauge.

Refitting

- 10 Reverse instructions 1 to 9.

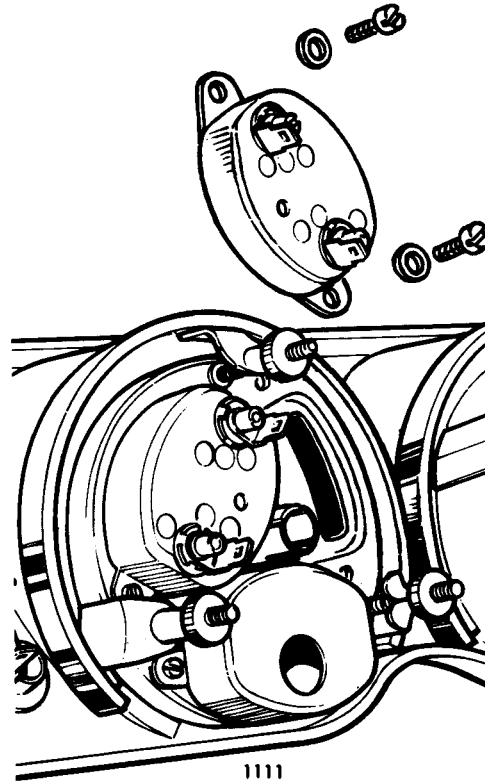

COOLANT TEMPERATURE TRANSMITTER

Remove and refit

88.25.20

Removing

- 1 Partly drain the engine coolant.
- 2 Locate the transmitter at the cylinder head as follows:
2.6 litre Petrol – at RH side forward of carburetter;
2½ litre Diesel – in adaptor at LH side rear, top;
2½ litre Petrol – in adaptor at RH side beneath thermostat housing.
- 3 Disconnect the electrical lead.
- 4 Remove the temperature transmitter.

Refitting

- 5 Reverse instructions 1 to 4. Do not overtighten; check for coolant leakage after initial engine run.

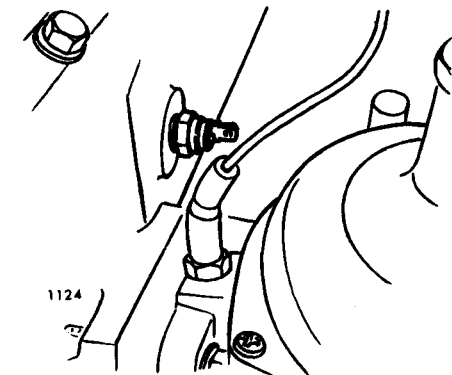
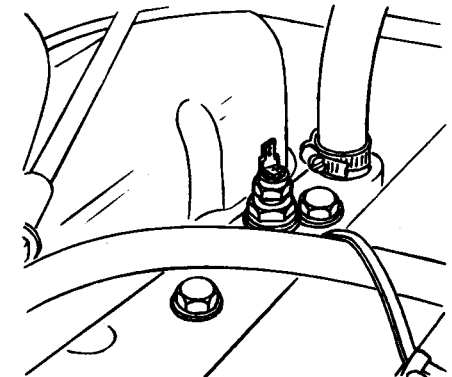
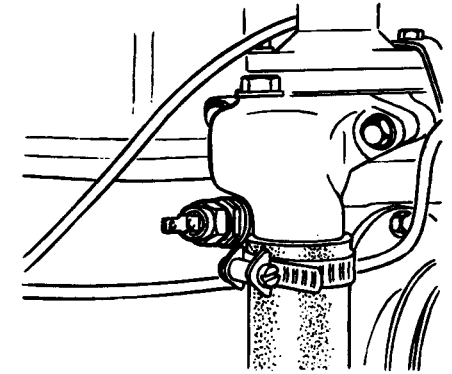

FUEL GAUGE**Remove and refit****88.25.26****Removing**

- 1 Disconnect the battery.
- 2 Remove the two screws securing the instrument panel to the fascia.
- 3 Withdraw the instrument panel.
- 4 Withdraw the bulb holders (2) from the grouped gauge assembly.
- 5 Disconnect the terminals, from the fuel gauge and temperature gauge.
- 6 Remove the three knurled nuts securing the grouped gauge assembly to the instrument panel.
- 7 Withdraw the three clamp brackets. Note the earth connection eyelet fitted to the top stud.
- 8 Withdraw the grouped instrument assembly.
- 9 Remove the two screws securing the fuel gauge and withdraw the fuel gauge.

Refitting

- 10 Reverse instructions 1 to 9.

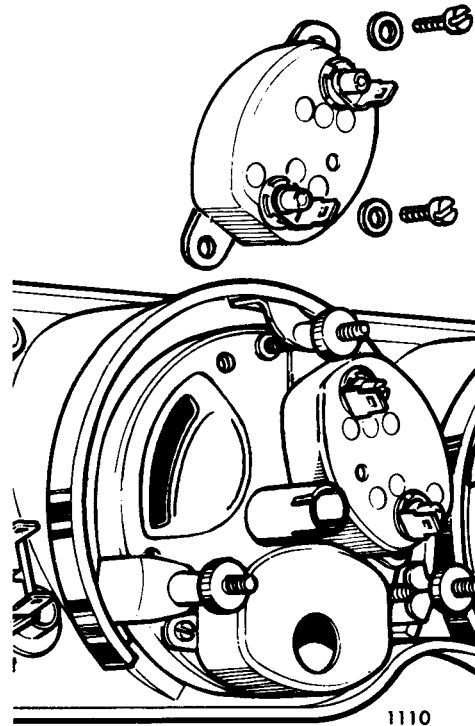
**FUEL TANK GAUGE UNIT (Rear mounted tank)****Remove and refit****88.25.32****Removing**

- 1 Disconnect the battery.
- 2 Remove the inspection cover in the rear floor.
- 3 Mark the gauge unit position in relation to the tank.
- 4 Disconnect the electrical feed lead.
- 5 Disconnect the earth lead at the gauge fixing.
- 6 Remove the retaining fixings and withdraw the gauge unit.

Refitting

- 7 Fit the gauge unit, using a suitable fuel resistant jointing compound ('Osotite' or similar) on the new joint washer.
- 8 Reverse instructions 1 to 5.

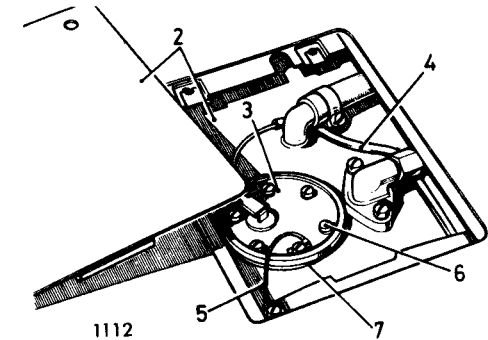
**FUEL TANK GAUGE UNIT (Side mounted tank)****Remove and refit****88.25.32****Removing**

- 1 Disconnect the battery.
- 2 Remove the RH seat cushion and tank cover panel.
- 3 Disconnect the electrical lead(s) at the gauge unit.
- 4 Mark the gauge unit position in relation to the tank.
- 5 Remove the fixings and withdraw the gauge unit.

Refitting

- 6 Fit the gauge unit, using a suitable fuel resistant jointing compound ('Osotite' or similar) on the new joint washer.
- 7 Connect the electrical lead/s as follows:
Green/black lead to connector T;
white/green lead (vehicles with fuel level warning light only) to connector W;
the gauge unit is earthed through the tank-to-chassis fixings.
- 8 Reverse instructions 1 to 3.

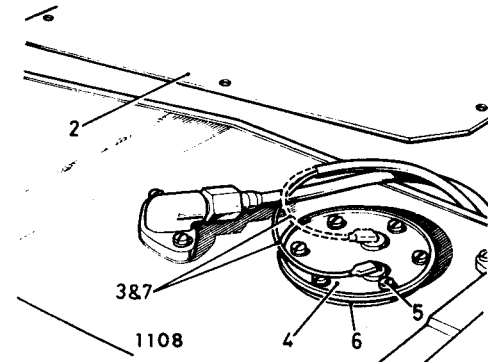

SPEEDOMETER

Remove and refit

88.30.01

Removing

- 1 Disconnect the battery.
- 2 Remove the two screws securing the instrument panel to the fascia and ease the panel clear of the fascia.
- 3 Depress the clip on the speedometer cable and withdraw the cable from the speedometer.
- 4 Withdraw the bulb holders (4) from the speedometer.
- 5 Disconnect the terminals from the voltage stabilizer.
- 6 Remove the two knurled nuts securing the speedometer to the instrument panel.
- 7 Release the three earth connections eyelets and remove the two clamp brackets.
- 8 Withdraw the speedometer.
- 9 Remove the voltage stabilizer.

Refitting

- 10 Reverse instructions 1 to 9.

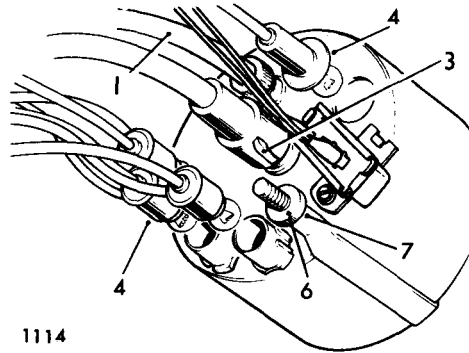

1114

SPEEDOMETER CABLE

Remove and refit

Cable complete, instructions 1, 2, 4, 5 and 6 88.30.06

Inner cable, items instructions 1, 2, 3 and 6 88.30.07

Removing

- 1 Withdraw the instrument panel and disconnect the speedometer cable. 88.20.01 (instructions 1 to 4).
- 2 Withdraw the speedometer cable end into the engine compartment.
- 3 Withdraw the inner cable from the outer.
- 4 Detach the speedometer cable grommets from the securing clips at the engine, flywheel housing, chassis side-member and transfer gearbox.
- 5 Disconnect the cable at the gearbox.

Refitting

- 6 Reverse items 1 to 5 as applicable. When replacing the inner cable, grease sparingly with general purpose grease. Ensure that the inner cable is engaged in the drive slot at the gearbox.

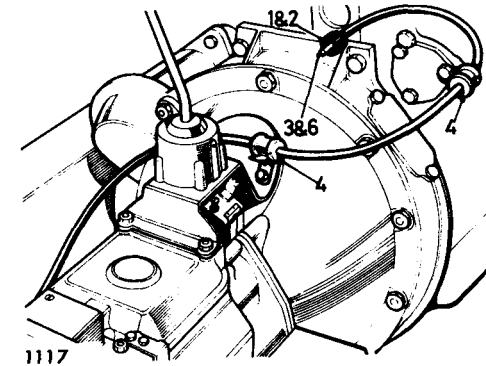

1117

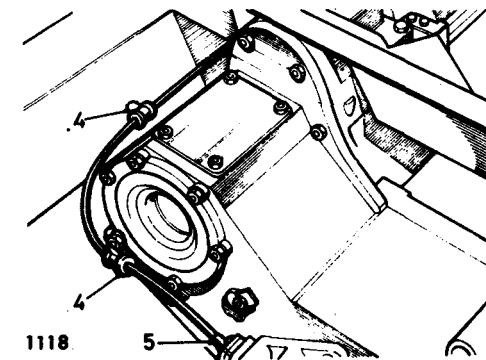

1118

SERVICE TOOLS

ENGINE

- 246650. Cylinder liner press block (2.6 Petrol)
- 261288. Reboring jig block (2.6 Petrol)
- 262749. Extractor—side rocker shaft (2.6 Petrol)
- 270304. Guide—rear bearing cap seals
- 271482. Injector cap spanner (2½ Diesel)
- 271483 (18G 109A). Test gauge—injector (2½ Diesel)
- 274389. Reamer—camshaft bearings (2½ Engines)
- 274399. Drift—push rod tube and injector shroud (2½ Diesel)
- 274400. Drift—inlet valve guide
- 274401. Drift—exhaust valve guide
- 276102. (18G 106). Valve spring compressor
- 278181. Injector—nozzle flushing tool (2½ Diesel)
- 278182. Injector—adaptor (2½ Diesel)
- 507231. Extractor—camshaft sprocket
- 530101. Extractor and puller
- 530101A. Extractor—tappet guide
- 530102. Spanner—starting dog and differential (three-bearing engine)
- 530102A. Spanner—starting dog and differential (three- and five-bearing engines)
- 530625. Adaptor—exhaust valve seats
- 600959. Drift—exhaust valve seats
- 600963. Engine sling

- 601508. Drift—inlet valve guides
- 605003. Injector nozzle cleaning wire
- 605052. Tool—removing immersion heater plug
- 605238. Plastigage
- 605863. Injection pump timing tool (2½ Diesel)
- 605975. Tool—remove/refit camshaft bearings (2½ Engines)
- 606445. Spanner—cylinder head (2½ Diesel)

GEARBOX

- 243241. Protection cap—gearbox output shaft
- 600300. Spanner—mainshaft nut
- 605022. Mandrel—clutch centre plate
- 605862. Extractor—transfer box, intermediate shaft
- RO 1013. Torque adaptor—gearbox mainshaft nut

STEERING

- 60000. Extractor—drop arm
- 600536. Compressing tool—steering relay spring
- 601763 (JD 24). Removal tool—steering ball joints

AXLE

- 262757. Extractor—differential pinion bearing (Rover-type axle)
- 262757-1. Adaptor—pinion bearing cup replacer
- 262758. Press block—pinion bearing
- 275870. Bearing remover—axle shaft
- 530105. Spanner—differential (Rover-type axle)
- 530106. Bracket—dial indicator gauge
- 605004. Gauge—differential pinion (Rover-type axle)
- 606435. Spanner—hub nut
- 18G 47 BK. Adaptor—pinion bearing cone remover/replacer (Salisbury-type axle)
- 18G 47 BL. Adaptor—removing differential bearing cones (Salisbury-type axle)
- 18G 131 C. Spreader—differential case (Salisbury-type axle)
- 18G 131 F. Adaptor pins—axle spreader (Salisbury-type axle)
- 18G 134 DP. Adaptor—differential bearing replacer (Salisbury-type axle)
- 18G 191. Dial gauge, bracket and base
- 18G 191P. Pinion setting gauge (used with 18G 191)
- 18G 1122. Bearing cup replacer (Salisbury-type axle)
- 18G 1122G. Adaptor—pinion bearing cups (Salisbury-type axle)
- 18G 1205. Flange holding wrench
- 18G 1349. Hub oil seal replacer

RO 1008. Pinion oil seal replacer (Salisbury-type axle)

RO 1010. Spanner—front hub nut (109 Models)

S 123A. Pinion bearing cup remover

BODY

262771. Filler strip tool

GENERAL

47. Hand press

284. Impulse extractor

18G 134. Universal drift

SERVICE TOOLS

ENGINE

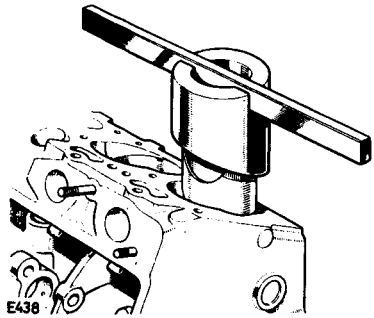

246650. Cylinder liner press block (2.6 Petrol)

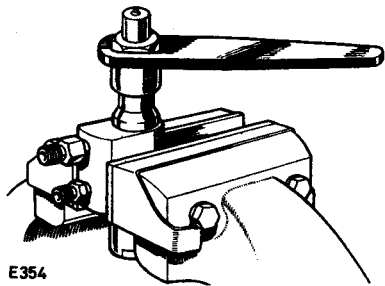

271482. Injector cap spanner (2 1/4 Diesel)

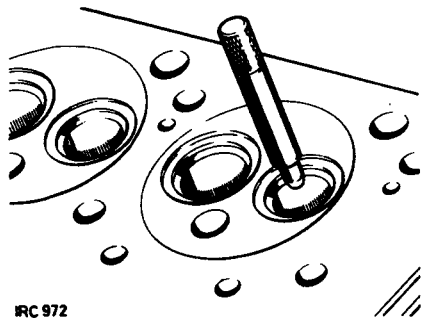

274400. Drift—inlet valve guide

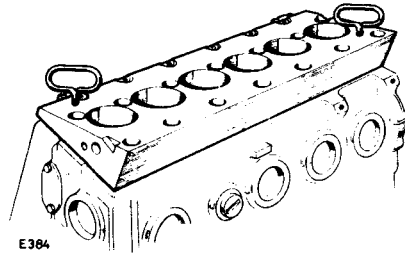

261288. Reboring jig block (2.6 Petrol)

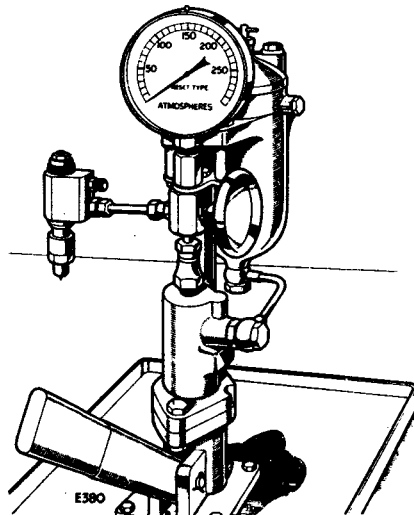

271483 (18G 109A). Test gauge—injector (2 1/4 Diesel)

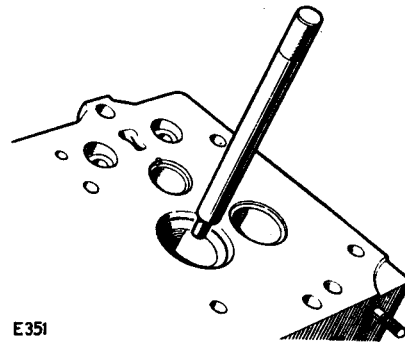

274401. Drift—exhaust valve guide

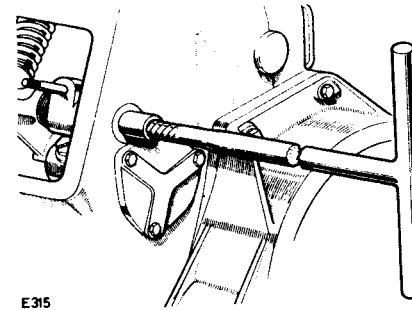

262749. Extractor—side rocker shaft (2.6 Petrol)

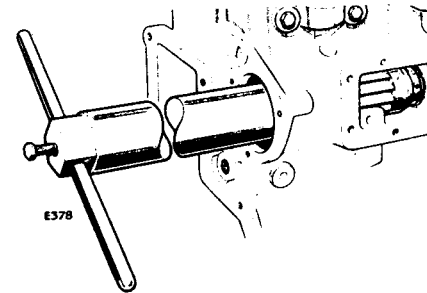

274389. Reamer—camshaft bearings (2 1/4 Engines)

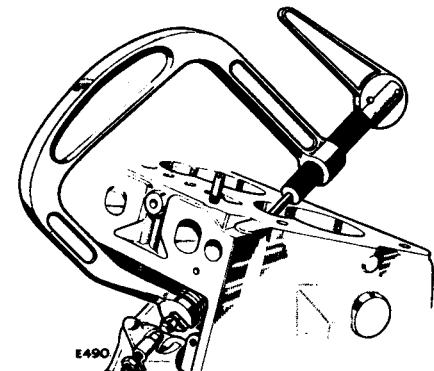

276102 (18G 106). Valve spring compressor

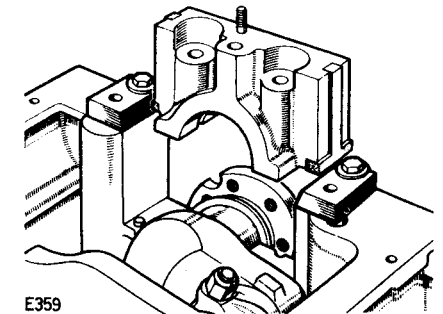

270304. Guide—rear bearing cap seals

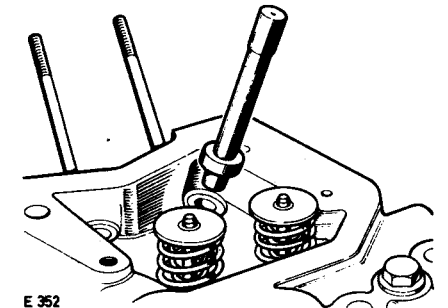

274399. Drift—push rod tube and injector shroud (2 1/4 Diesel)

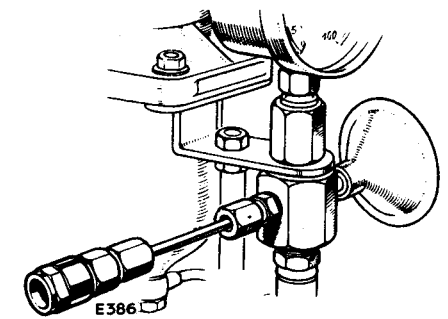

278181. Injector—nozzle flushing tool (2 1/4 Diesel)

continued

ENGINE

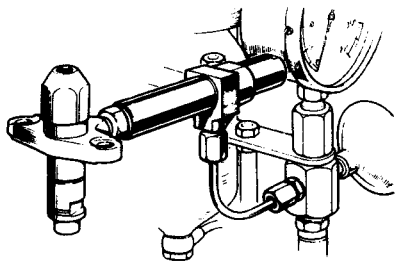

4RC987A

278182. Injector—adaptor (2 1/4 Diesel)

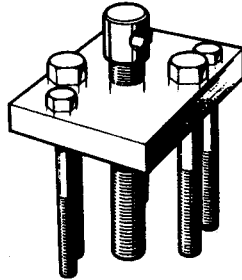

IRC 940

507231. Extractor—camshaft sprocket

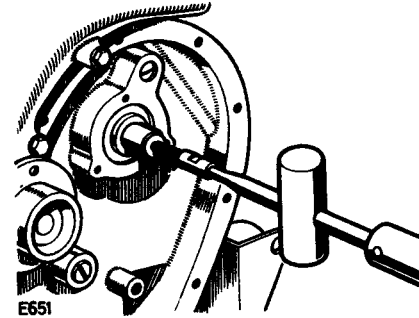

E651

530101. Extractor and puller

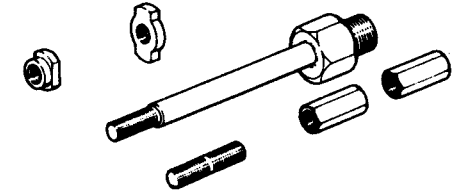

530101A. Extractor—tappet guide

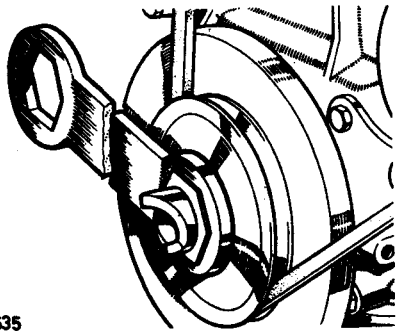

E635

530102. Spanner—starting dog and differential

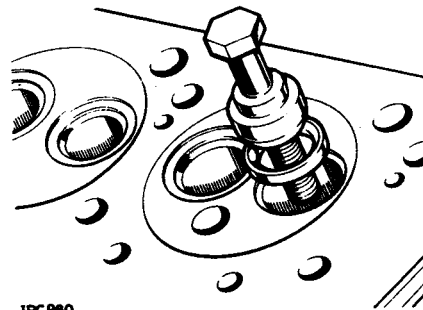

IRC980

530625. Adaptor—exhaust valve seats

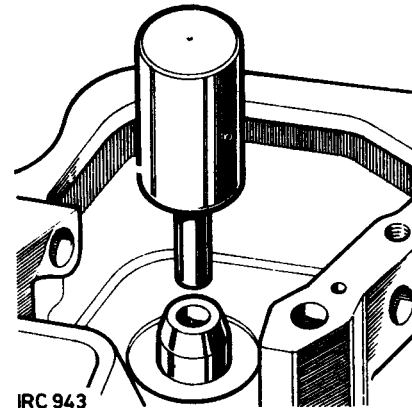

IRC 943

600959. Drift—exhaust valve seats

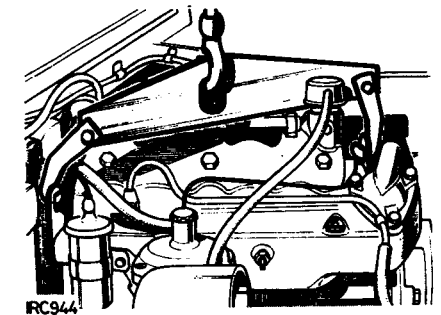

RC944

600963. Engine sling

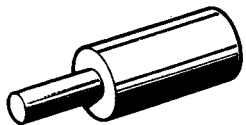

IRC 945

601508. Drift—inlet valve guides

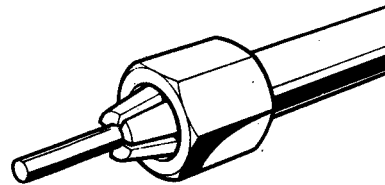

IRC947

605003. Injector nozzle cleaning wire

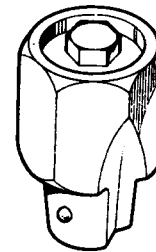

IRC 950

605052. Tool—removing immersion heater plug

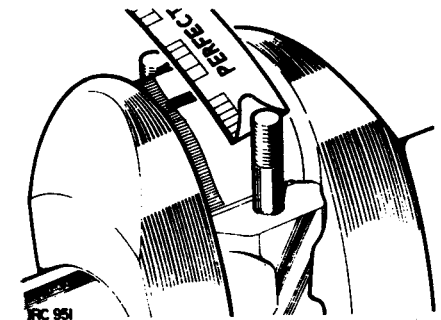

RC 951

605238. Plastigage

continued

ENGINE

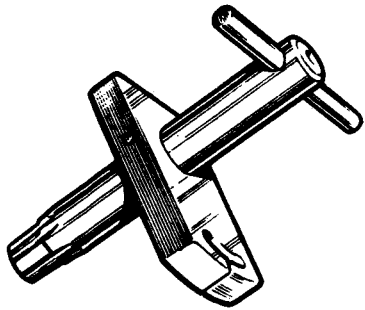

IRC 953
605863. Injection pump timing tool (2 1/4 Diesel)

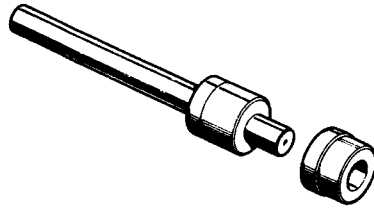

IRC 954
605975. Tool—remove/refit camshaft bearings (2 1/4 Engines)

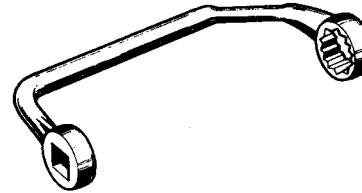

IRC 955
606445. Spanner—cylinder head (2 1/4 Diesel)

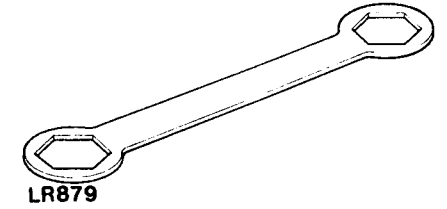

LR879
530102A. Starting dog nut (three- and five-bearing engines)

GEARBOX

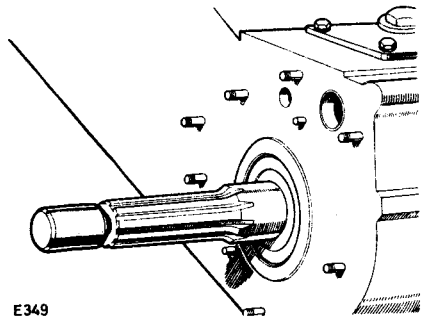

E349
243241. Protection cap—gearbox output shaft

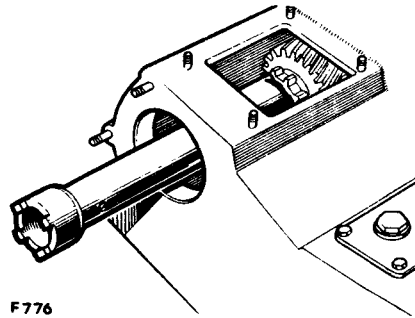

F776
600300. Spanner—mainshaft nut

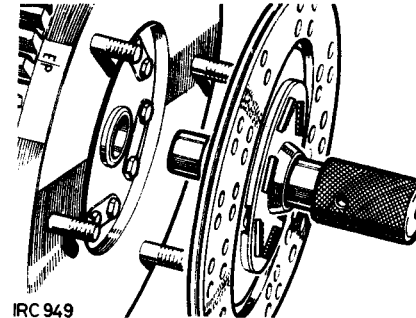

IRC 949
605022. Mandrel—clutch centre plate

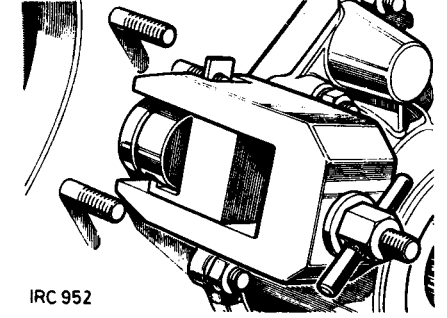

IRC 952
605862. Extractor—transfer box, intermediate shaft

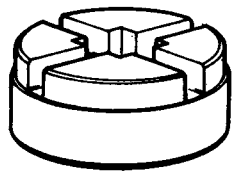

RO 1013. Torque adaptor—gearbox mainshaft nut

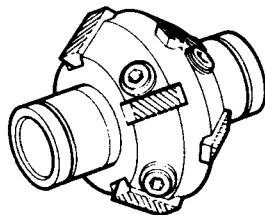

MS 621, MS 627. Inlet and exhaust valve seat cutter

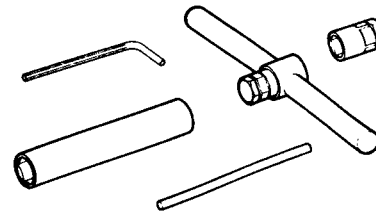

MS 76. Cutter hand set

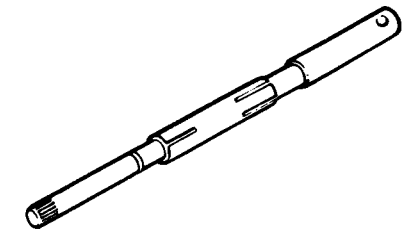

MS 150-8, MS 150-8.5 Adjustable pilots cutter

STEERING

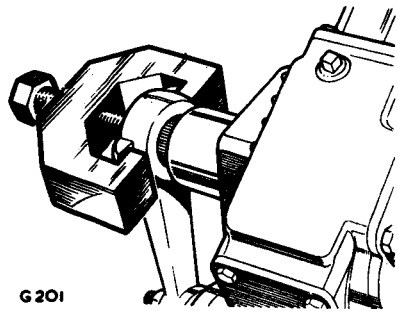

G201
60000. Extractor—drop arm

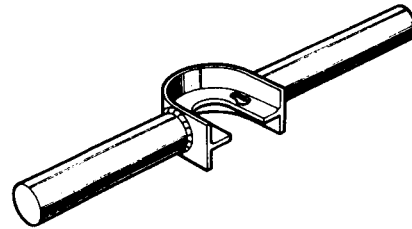

IRC 942
600536. Compressing tool—steering relay spring

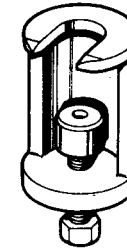

IRC 946
601763 (JD 24). Removal tool—steering ball joints

AXLE

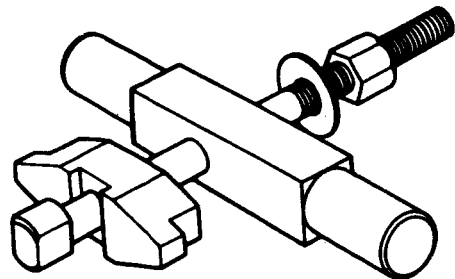

262757. Extractor—differential bearing (Rover-type axle) pinion

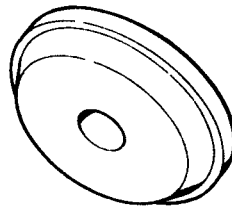

262757-1. Adaptor—pinion bearing cup replacer

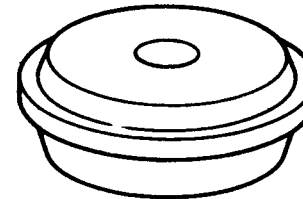

262758. Press block—pinion bearing

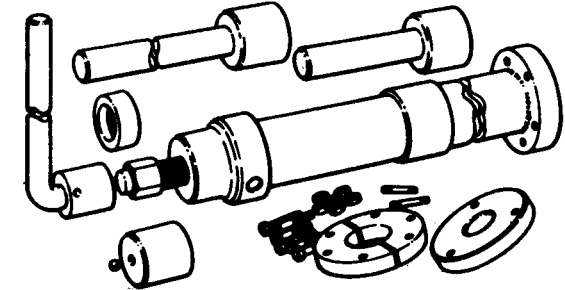

275870. Bearing remover—axle shaft



IRC 941
530105. Spanner—differential (Rover-type axle)

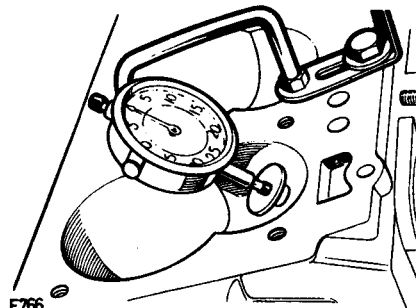

F766
530106. Bracket—dial indicator gauge

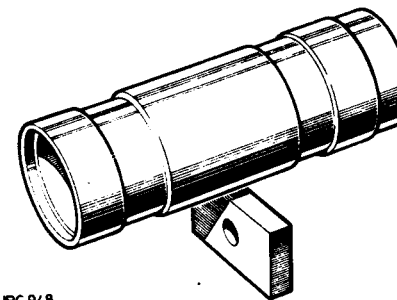

IRC 948
605004. Gauge—differential pinion (Rover-type axle)

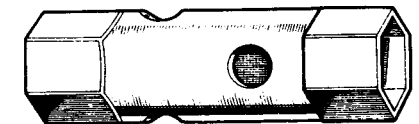

RC 956
606435. Spanner—hub nut

continued

AXLE

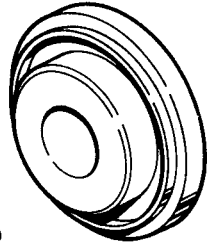

LR880

18G 1349. Hub oil seal replacer

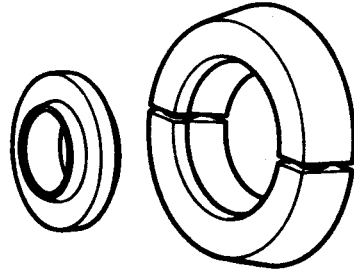

18G 47 BK. Adaptor-pinion bearing cone remover/replacer (Salisbury-type axle)

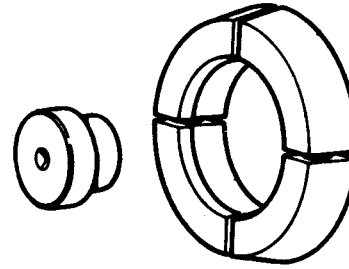

18G 47 BL. Adaptor-removing differential bearing cones (Salisbury-type axle)

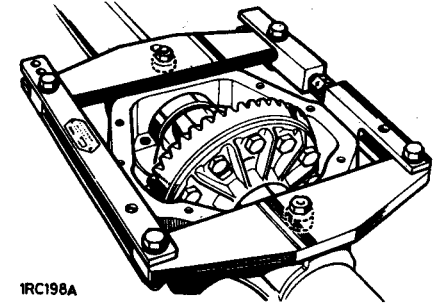

18G 131 C

18G 131 C. Spreader-differential case (Salisbury-type axle)

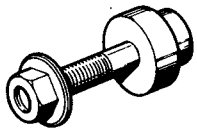

IRC 967

18G 131 F. Adaptor pins-axle spreader (Salisbury-type axle)

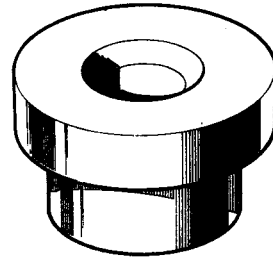

IRC 965

18G 134 DP. Adaptor-differential bearing replacer (Salisbury-type axle)

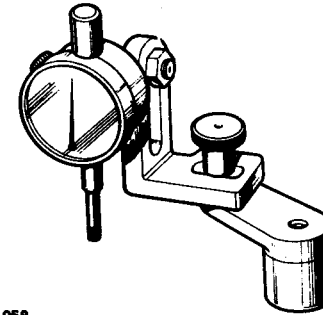

IRC 958

18G 191. Dial gauge, bracket and base

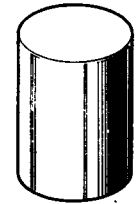

IRC 966

18G 191P. Pinion setting gauge (used with 18G 191)

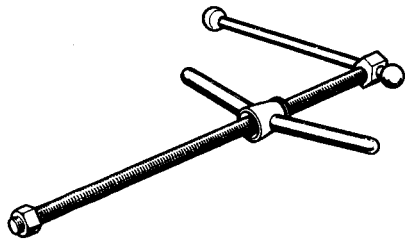

IRC 959

18G 1122. Bearing cup replacer (Salisbury-type axle)

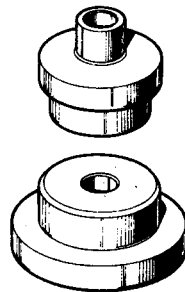

IRC 964

18G 1122G. Adaptor-pinion bearing cups (Salisbury-type axle)

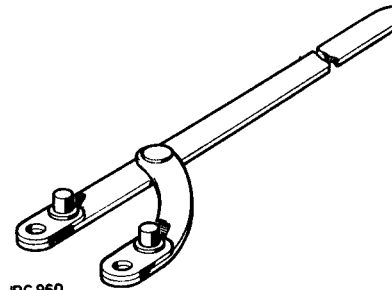

IRC 960

18G 1205. Flange holding wrench

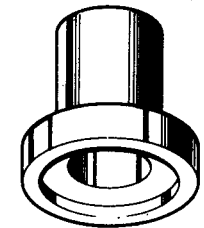

RO 1008

RO 1008. Pinion oil seal replacer (Salisbury-type axle)

continued

AXLE

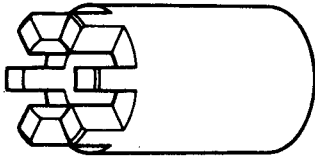

RO 1010. Spanner—front hub nut (109 Models)

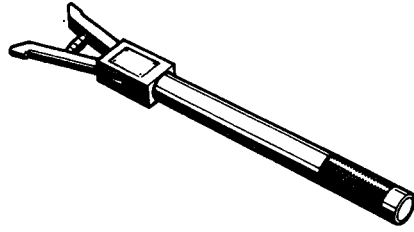

**IRC 961
S 123A. Pinion bearing cup remover**

BODY



**FC 938
262771. Filler strip tool**

GENERAL

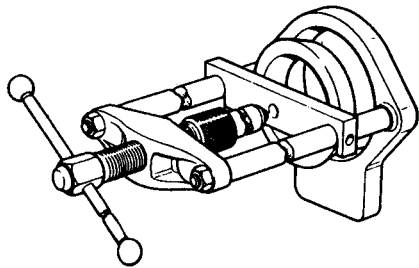

47. Hand press

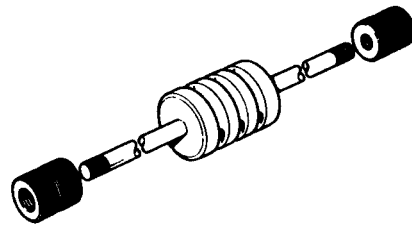

284. Impulse extractor

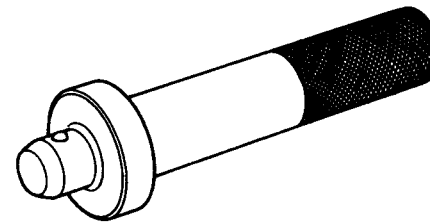

18G 134. Universal drift



LAND ROVER

Series III

**FIVE MAIN BEARING ENGINE
SUPPLEMENT**

INTRODUCTION

This supplement must be used in conjunction with the current Land Rover Series III Repair Operation Manual.

The introduction of a five main bearing crankshaft to the 2¼ litre petrol and diesel engine has caused changes to some repair operations. The operations concerned have been revised and are included in this publication together with details of the differences between the new engines and the existing three bearing units.

Since the new petrol engine is manufactured at different plants, some variations exist and for purposes of identification two commencing serial numbers have been allocated namely 36100001A and 99100001A. The diesel engine commencing number is 36600001A.

Set out below are the principal differences between the three and five main bearing petrol engines and the variations between the two five main bearing units. Parts common to diesel engine serial number range 36600001A are also mentioned.

Crankshaft

Redesigned to include five main bearings. The main bearing journal and crankpin dimensions remain the same as for the three bearing shaft. The five bearing shaft fitted to commencing serial number range 36100001A is a casting whereas a forged shaft is used in serial number range 99100001A and the diesel engine. Whilst a cast crankshaft must not be fitted to engines in serial range 99100001A and the diesel version a forged may be used in serial number range 36100001A. Forged crankshafts, however, will only be supplied for spares.

Cylinder Block

Redesigned to accommodate five main bearings. Sealing of the rear main bearing changed to a lip type seal pressed into the flywheel housing. The outside diameter of the crankshaft flange runs in the seal. The relevant repair operations have been revised and included in this supplement.

Camshaft

The valve timing of the camshaft fitted to the engine serial number range 36100001A is as follows.

Inlet opens	6° BTDC
Inlet closes	52° ABDC
Inlet peak	113° ATDC
Exhaust opens	34° BBDC
Exhaust closes	24° ATDC
Exhaust peak	95° BTDC

Number one exhaust cam peak is on the centre line of camshaft keyway.

The camshaft sprocket retaining bolt has a UNF thread.

Valve timing for the camshaft fitted to serial number range 99100001A and diesel engine number range 36600001A is:

Inlet opens	16° BTDC
Inlet closes	42° ABDC
Inlet peak	103° ATDC
Exhaust opens	51° BBDC
Exhaust closes	13° ATDC
Exhaust peak	109° BTDC

Number one exhaust cam peak on the camshaft fitted to serial number range 99100001A is 7° to the right of the keyway centre line viewed from the keyway end.

The camshaft sprocket retaining bolt has a metric thread.

Oil Pump

Interchangeable as an assembly between serial number range 36100001A and 99100001A. The pump gears, although different, are interchangeable with either assembly provided the gears are fitted as a matched set. The pump is interchangeable on serial number range 36100001A. The idler gear and the driver are both steel on serial number range 99100001A. On serial number range 36100001A the idler is aluminium and the driver steel.

INTRODUCTION

Flywheel

Design change to fit five main bearing crankshaft flange. Interchangeable between serial number ranges 36100001A and 99100001A but not with diesel engine range 36600001A.

Flywheel Housing

Design change to accommodate new crankshaft and rear main bearing oil seal arrangement. Interchangeable between serial number ranges 36100001A and 99100001A but not with diesel engine range 36600001A.

Timing Chain Tensioner

The timing chain tensioner assembly is the same as used on the three main bearing versions. The assembly fitted to serial number range 99100001A is the same as that used on diesel engine range 36600001A. The tensioner fitted to early petrol engine range 36100001A has a different piston assembly incorporating a relief valve. This has now been discontinued and all three engines now have the same tensioner. The ratchet on serial number range 99100001A is different in appearance and method of manufacture but dimensionally the same.

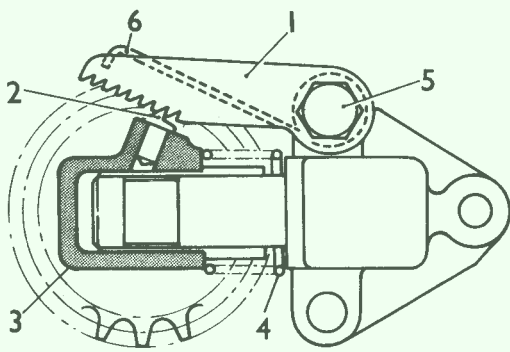

LR 667

**99100001A and 36600001A
engine serial no. range**

1. Ratchet
2. Pawl
3. Cylinder
4. Spring
5. Ratchet pivot and retaining bolt
6. Ratchet return spring
7. Jockey sprocket
8. Retaining clip for ball
9. Ball

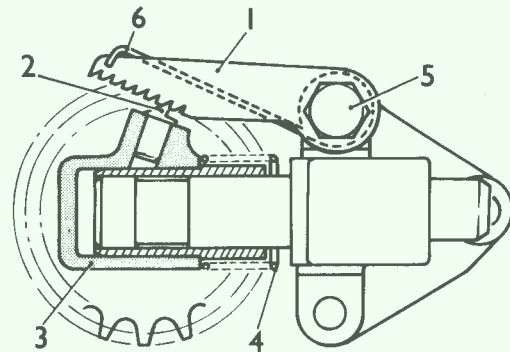

LR 666

**36100001A engine serial no. range
(Early engines only)**

1. Ratchet
2. Pawl
3. Cylinder
4. Spring
5. Ratchet pivot and retaining bolt
6. Ratchet return spring
7. Jockey sprocket
8. Relief valve spring
9. Relief valve ball
10. Relief valve plug
11. Piston assembly

Ignition Distributor

A Lucas type 45D4 with sliding contacts is fitted to engine serial number range 99100001A. Serial number range 36100001A is fitted with a Ducellier distributor.

Differences between the existing three main bearing diesel engine and the new five bearing unit serial number commencing 36600001A.

Cylinder Block

Crankcase redesigned to accommodate the five main bearing crankshaft. Sealing of the rear main bearing changed to a lip type seal pressed into the flywheel housing. The outer diameter of the crankshaft flange runs in the seal.

Crankshaft

Redesigned to include five main bearings. The main bearing journal and crankpin dimensions remain the same as the three bearing shaft.

Flywheel

Modified to fit redesigned crankshaft flange.

Flywheel Housing

Redesigned to accommodate new crankshaft rear main bearing oil seal arrangement.

Crankshaft Pulley

Changed to a damper type pulley incorporating a band of rubber between the hub and pulley sections. Also dimensional changes.

Starter Dog

Changed to that used on the five bearing petrol engines. Not interchangeable with the starter dog on the existing three bearing diesel engine.

Special Note

When fitting a five main bearing engine as a replacement for a three bearing unit a new flywheel housing and seal must also be ordered.

CONTENTS

	Operation number	Page number
Introduction		01-1

ENGINE OPERATIONS

Crankshaft

– rear oil seal – remove and refit	12.21.20	12-3
– remove and refit	12.21.33	12-4

Flywheel

– remove and refit	12.53.07	12-8
--------------------------	----------	------

FUEL SYSTEM OPERATIONS

Fuel Injection Pump

– remove and refit	19.30.07	19-2
--------------------------	----------	------

ELECTRICAL OPERATIONS

Contact Breaker Points (Ducellier)

– remove and refit	86.35.13	86-2
--------------------------	----------	------

Contact Breaker Points (Lucas)

– remove and refit	86.35.13	86-3
--------------------------	----------	------

Distributor (Ducellier)

– overhaul	86.35.26	86-5
------------------	----------	------

ENGINE

OPERATIONS

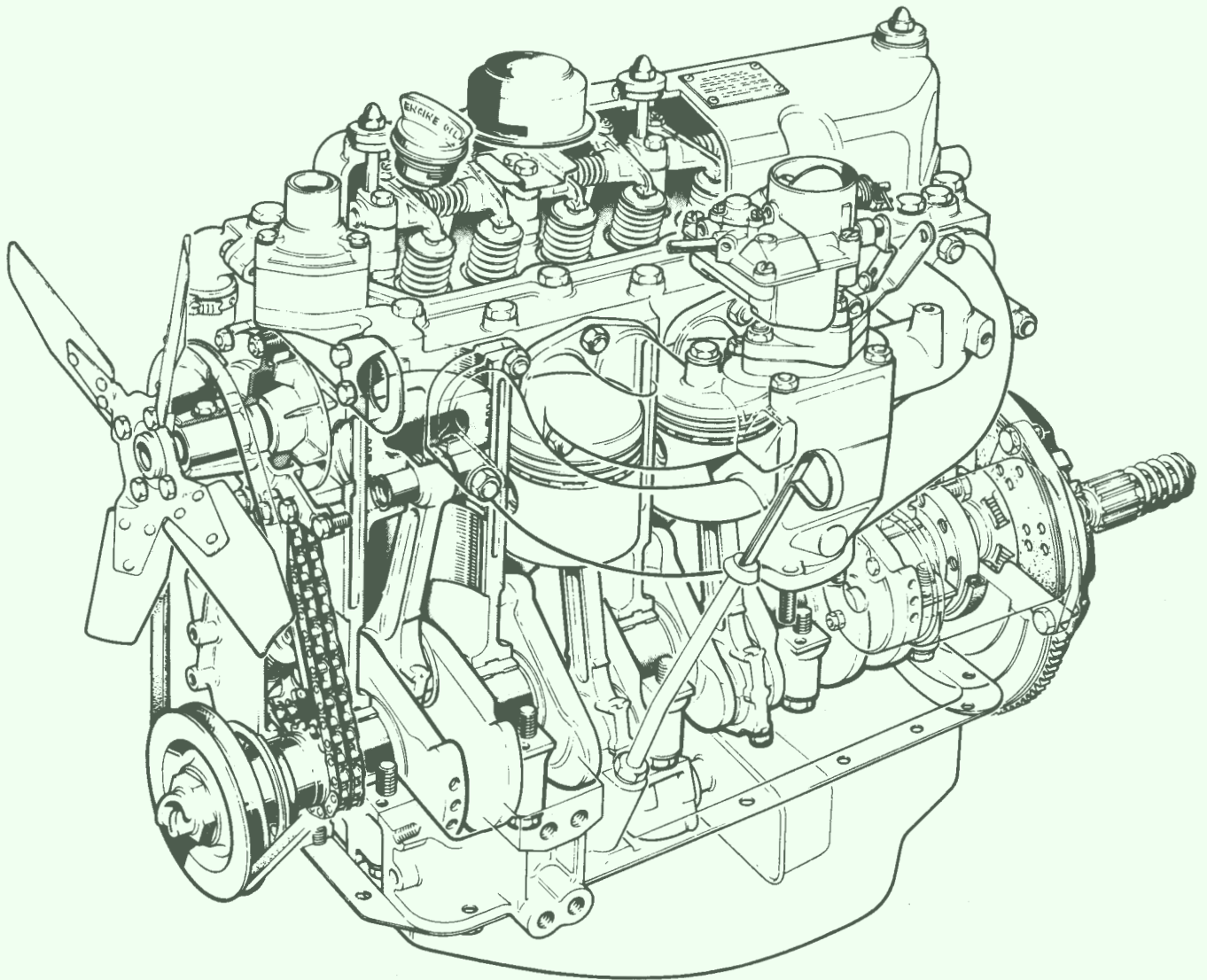

Land Rover 2 1/4 litre five main bearing Petrol Engine

CRANKSHAFT REAR OIL SEAL

-Remove and refit

12.21.20

Service tool 18G1344 Seal guide

Removing

1. Remove the engine from the vehicle leaving the gearbox in position in the chassis 12.41.01.
2. Remove the clutch assembly, instructions 4 to 7 33.10.01.
3. Remove the retaining bolts and withdraw the flywheel.
4. Remove the flywheel housing complete with rear main oil seal.
5. Remove and discard the flywheel housing 'O' ring.
6. Carefully remove and discard the oil seal.

Refitting

NOTE: The satisfactory operation of the rear main oil seal in service depends upon the care and cleanliness exercised during the following instructions.

7. Check that the crankshaft oil seal journal is not damaged and is clean.
8. Make sure the seal housing is clean and dry and free from burrs.
9. Taking care not to touch the seal lip ensure that the outside diameter is clean and dry.
10. With the lip side leading, slowly press in the seal, square to the bore of the seal housing, until the seal is flush or a maximum of 0.50mm (0.020 in) below the outer face of the flywheel housing.
11. Fit the 'O' ring seal to the flywheel housing.
12. Examine the seal guide number 18G1344 and repair any damage that could destroy the seal lip.
13. Lubricate the outside diameter of the seal guide and the seal journal with concentrated "Oildag" in a 25% solution with clean engine oil.
14. Place the seal guide on the crankshaft flange and, using the two dowels, protruding from the cylinder block rear face, as a guide to ensure initial squareness, fit the flywheel housing and remove the seal guide.
15. Secure the flywheel housing evenly tightening the retaining bolts.
16. Fit the flywheel, following instructions 5 to 8 in operation 12.53.07 of this supplement.
17. Fit the clutch, instructions 8 and 9 33.10.01.
18. Smear the splines of the primary shaft, the clutch centre splines and the withdrawal unit abutment faces, with molybdenum disulphide grease, such as 'Rocol' MTS 1000.
19. Refit the engine.

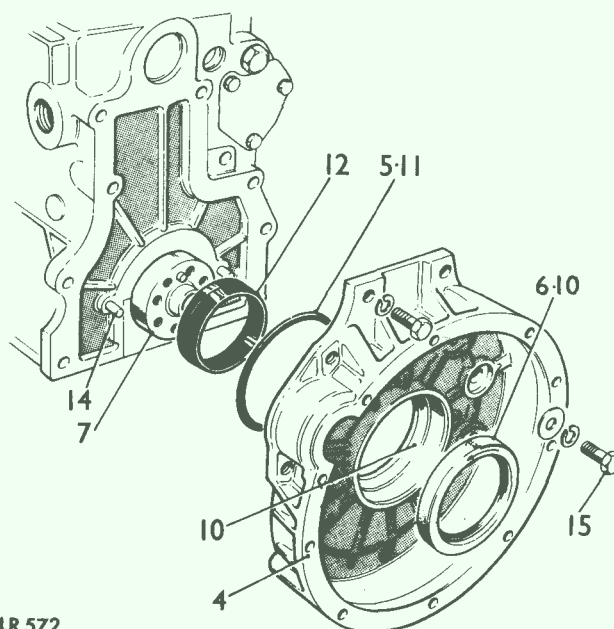
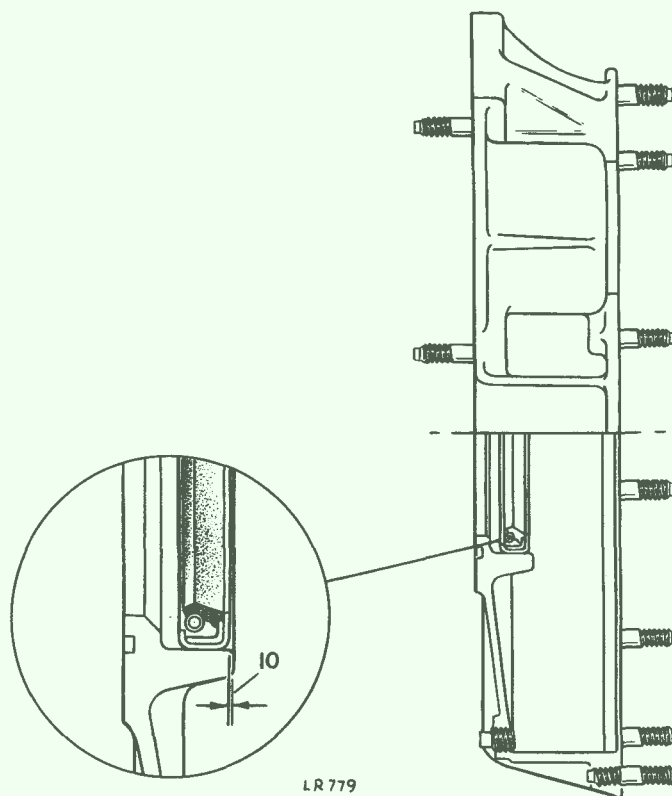

CRANKSHAFT

—Remove and refit

12.21.33

Special tools 270304 Cork seal guides
530102 Starter dog spanner

Removing

1. Remove the bonnet, 76.16.01.
2. Remove the air cleaner, 19.10.04.
3. Remove the radiator and front panel assembly complete.
4. Remove the front floor, 76.10.12.
5. Drain the oil sump.
6. Remove the engine assembly leaving the gearbox in position 12.41.01.
7. Remove the sump.
8. Remove the oil pump and strainer assembly complete with drive shaft.
9. Using a suitable piece of timber jam the crankshaft and remove the starter dog with special spanner 530102.
10. Remove the timing chain cover following instructions 3, 4, 7 and 8 to 13 operation 12.65.01.
11. Remove the timing chain tensioner.
12. Remove the timing chain from the sprockets.
13. Remove the clutch assembly.
14. Remove the flywheel.
15. Remove the flywheel housing complete with rear main oil seal and 'O' ring.
16. Remove the connecting rod caps and lower bearing shells and push the connecting rods clear of the crankpins taking care not to damage the pistons and valves.
17. Cover the connecting rod bolt threads with thin plastic or rubber sleeves to prevent damage to the crankpins.
18. Remove the five main bearing caps and lower shells.
19. Lift out the crankshaft.
20. If required, remove the chainwheel and key from the crankshaft.

Refitting

NOTE: If replacement components are to be fitted the checks detailed in operation 12.21.46 must be carried out.

21. Locate the main bearing halves in the crankcase and lubricate with engine oil.
22. Check the crankshaft end-float which should be 0,05mm to 0,15mm (0.002 to 0.006in.) by following instructions 23 to 26.
23. Position a standard size thrust washer each side of the centre main bearing saddle with the unplated faces towards the cylinder block.

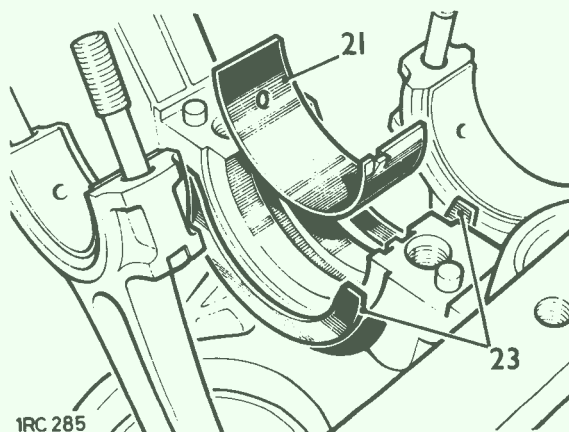

1RC 285

Continued

24. Rest the crankshaft in position in the crankcase.
25. Mount a dial test indicator to read-off the end of the crankshaft and check the end-float.
26. If adjustment is required, substitute with oversize thrust washers – see data to obtain the required end-float. The variation of thrust washer thickness at each side must not exceed 0,08mm (0.003in.) to ensure that the crankshaft remains centralised.
27. Locate the bearing halves in the main bearing caps and fit cap numbers 1 to 4 ensuring that they locate properly over the dowels. Loosely secure with new bolts.

NOTE: New bolts and washers must be fitted on petrol engine serial number range 36100001A, 99100001A and diesel engine range 36600001A. See note following instruction 32.

28. Ensure that number five main bearing cap is clean and free from old cork seal material.
29. Attach the cork seal guides number 270304 to the crankcase, as illustrated, and ensure that they are parallel to the crankcase edge.

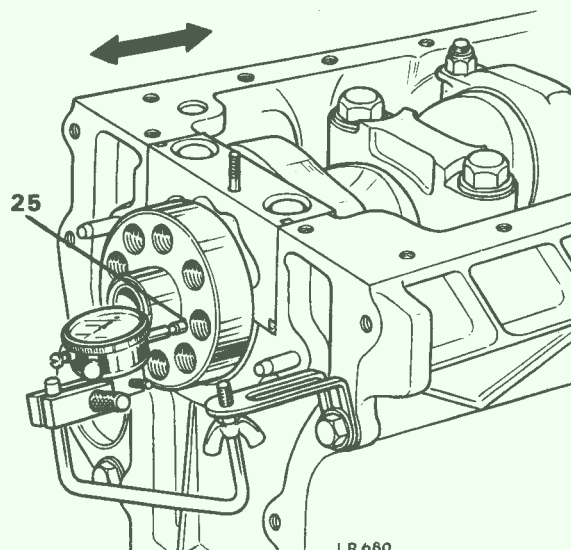

Continued

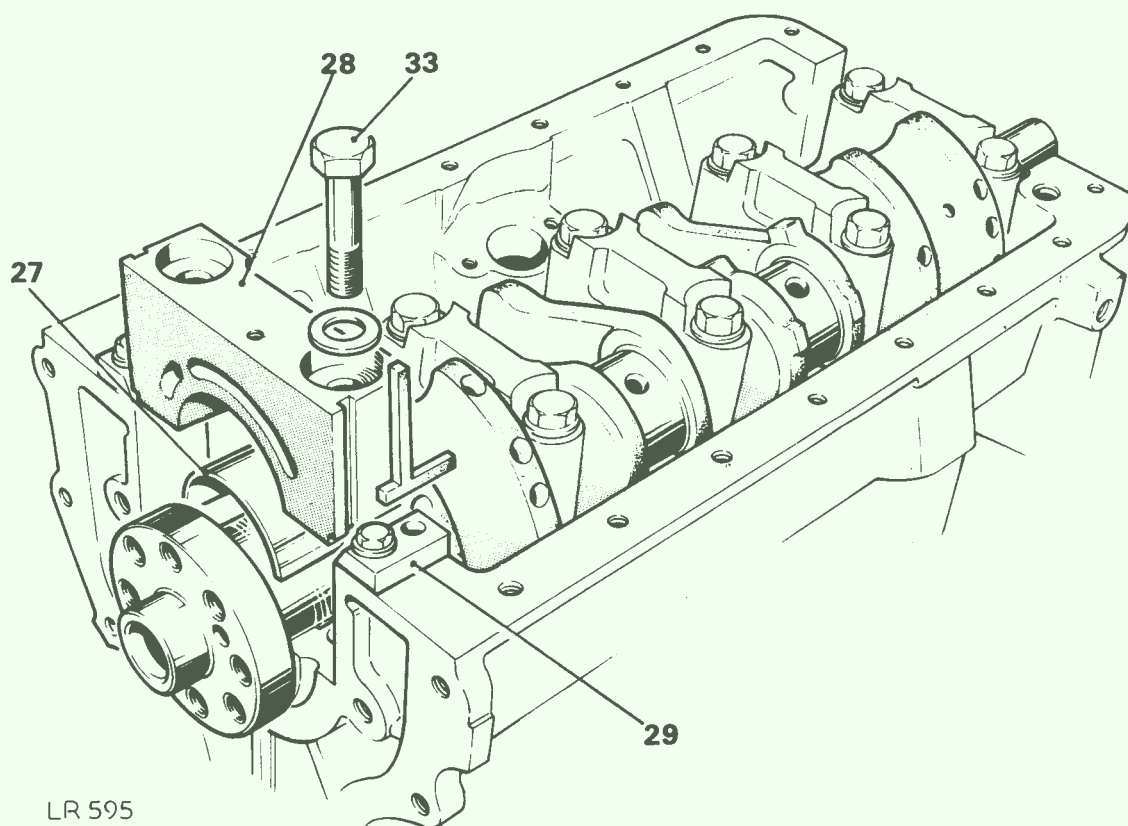

30. To prevent any cork seal material becoming trapped between the bearing cap and crankcase, chamfer the inner edge of the corks 0,40 to 0,80mm (1/64 to 1/32in.) wide as illustrated.
31. Immerse the cork seals in engine oil and fit them to the bearing cap.
32. Fit the cap to the cylinder block and loosely secure with new bolts. See note following instruction 27 above.

CAUTION: Petrol engine serial number range commencing 99100001A employ plain washers and diesel engine specifications bolts. These bolts are not interchangeable with those on serial number range 36100001A, where spring washers are used.

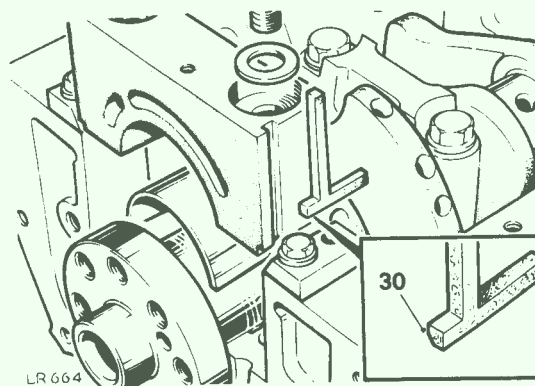

33. Commencing with the centre main bearing evenly tighten the bolts to 11,5kgf.m. (85lbf.ft.) for engine serial number range 36100001A and 13 to 14kgf.m. (100lbf.ft.) for serial range 99100001A and diesel engine range 36600001A.
34. To allow for shrinkage after fitting leave the cork seals standing proud of the crankcase-ump face. If possible delay the fitting of the sump for approximately twelve hours and leave the seal protruding 2,40mm (3/32in.) and then place a 6,350mm (1/4in.) washer over the seal and cut off the surplus. If it is necessary to fit the sump immediately, trim the seals off leaving 0,80mm (1/32in.) proud, that is, the thickness of the above washer.
35. Apply Hylomar SQ32M to the protruding end of the seals.
36. Fit the appropriate bearing halves and caps to the connecting rods using new nuts and tighten to 3,5 kgf.m. (25lbf.ft.) for serial number range 36100001A and diesel engine range 36600001A. Tighten to 4,45kgf.m. (30 to 35lbf.ft.) for serial number range 99100001A.

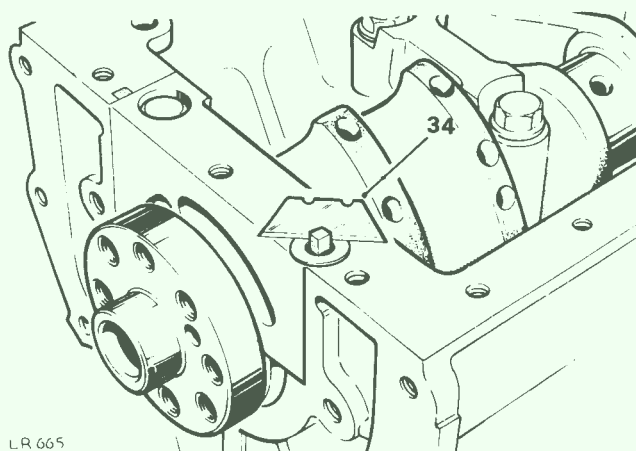

CAUTION: The connecting rod bolts have eccentric heads which locate in slots in the connecting rod. It is essential that the bolt heads are properly located before tightening.

37. Fit the rear main oil seal and housing instructions 7 to 14 operation 12.21.20 of this supplement.
38. Fit the flywheel following instructions 5 to 8 operation 12.53.07 of this supplement.
39. Smear the splines of the primary shaft, the clutch centre splines and the withdrawal abutment faces with Molybdenum disulphide grease such as Rocol MTS1000.
40. Fit the clutch assembly 33.10.01.
41. Fit the timing chain tensioner.

Continued

42. Fit the timing chain cover and starter dog. Operation 12.65.01.
43. Fit the oil pump.
44. Fit the sump.
45. Fit the engine.
46. Fill the sump to the high mark on the dipstick with new oil of the recommended make and grade in accordance with the territory and temperature conditions under which the vehicle is operating.
47. Reverse instructions 1 to 4 of this operation.

DATA

Crankshaft

Journal diameter	63,5mm – 0,012mm (2.5in. – 0.0005in.).
Crankpin diameter	58,7mm (2.312in.).
End-float (controlled by thrust washers at centre bearing)	0,05mm to 0,15mm (0.002 to 0.006in.).
Thrust washers for the crankshaft centre main journal, to control the crankshaft end float, are available in the following oversizes:	0,06mm (0.0025in.). 0,12mm (0.005in.). 0,18mm (0.0075in.). 0,25mm (0.010in.).

Regrind sizes: – Petrol Engines only:

Undersize	Journal dia.	Crankpin Dia.
0,25mm (0.010in.)	63,24mm (2.490in.)	58,47mm (2.302in.)
0,50mm (0.020in.)	62,99mm (2.480in.)	58,22mm (2.292in.)
0,76mm (0.300in.)	62,73mm (2.470in.)	57,96mm (2.282in.)
1,01mm (0.040in.)	62,48mm (2.460in.)	57,70mm (2.272in.)

Connecting rod bearing running clearance	0,019mm to 0,063mm (0.0007in. to 0.0025in.).
Main bearing running clearance	0,020mm to 0,055mm (0.0008in. to 0.0022in.).

FLYWHEEL

—Remove and refit

12.53.07

Removing

1. Remove the engine from the vehicle leaving the gearbox in position 12.41.01.
2. Remove the clutch assembly, instructions 4 to 7, 33.10.01.
3. Remove the eight retaining bolts and remove the reinforcing plate.
4. Withdraw the flywheel.

Inspection

5. Examine the flywheel pressure face for wear, cracks and scores. Provided that the width of the flywheel is not reduced beyond the following dimension it may be refaced if necessary.

Petrol engines	34,72mm (1.375in.)
Diesel engines	36,957mm (1.455in.)

Refitting

6. Clean the crankshaft and flywheel mating faces. Remove burrs and repair damage that could cause the flywheel to run-out. Ensure that the dowel fits correctly in the flywheel and crankshaft flange.
7. Fit the flywheel and reinforcing plate to the crankshaft and tighten the retaining bolts to 13,8kgf.m. (100lbf.ft.).
8. Mount a dial test indicator to the flywheel housing so that the stylus rests in a loaded condition on the pressure face at a radius of 114mm (4.5in.). Check the runout which must not exceed 0,05mm (0.002in.).
9. If the run-out is excessive repeat instruction 6. If the cause of the run-out cannot be found renew the flywheel.
10. Fit the clutch, instructions 8 and 9, 33.10.01.
11. Smear the splines of the primary shaft, the clutch centre splines and the withdrawal unit abutment faces with Molybdenum disulphide grease such as 'Rocol MTS 1000'.
12. Refit the engine to the vehicle.

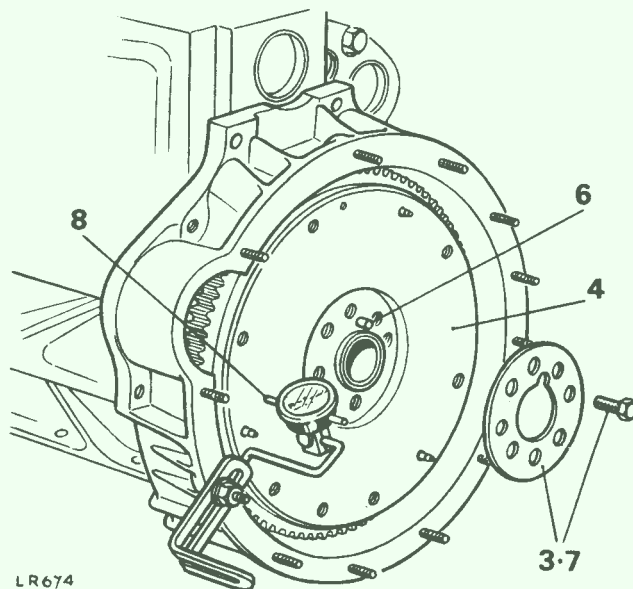

FUEL SYSTEM

OPERATIONS

FUEL SYSTEM

FUEL INJECTION PUMP

—Remove and refit

19.30.07

Service tool Timing gauge MS67B

Removing

1. Remove the bonnet panel 76.16.01.
2. Remove the air cleaner, 19.10.04.
3. Disconnect the battery earth lead.
4. Disconnect the engine stop cable.
5. Disconnect the stop lever return spring.
6. Remove the clevis pin and disconnect the accelerator cable.
7. Remove the fuel pipes, distributor pump to injectors.
8. Disconnect the inlet and outlet fuel pipes from the distributor.
9. Remove the distributor pump fixings.
10. Withdraw the distributor pump.
11. Withdraw the distributor pump drive shaft.

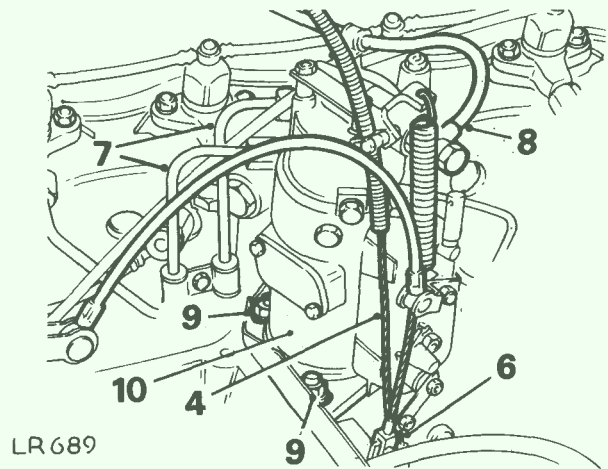

LR 689

Refitting and timing procedure

12. Remove the engine rocker cover.
13. Slacken the fixings and move aside the inspection cover on the flywheel housing to expose the timing pointer adjacent to the flywheel.
14. Turn the crankshaft in the direction of rotation until both valves of number one cylinder are closed and the piston is ascending the bore on the compression stroke.
15. Continue to turn the crankshaft until the timing pointer aligns with the 13° mark on the flywheel, that is 13° BTDC. This must be done carefully. If the flywheel is inadvertently turned too far and the timing mark goes past the pointer, do not turn the flywheel back, but repeat the operation.
Ensure that a correct line of vision is taken when lining up the timing marks. An incorrect line of vision can result in the timing being 1° to 2° out.
16. The master spline on the driving gear should now be approximately 20° from the centre line of engine measured from the front end, that is, at the 4 o'clock position.

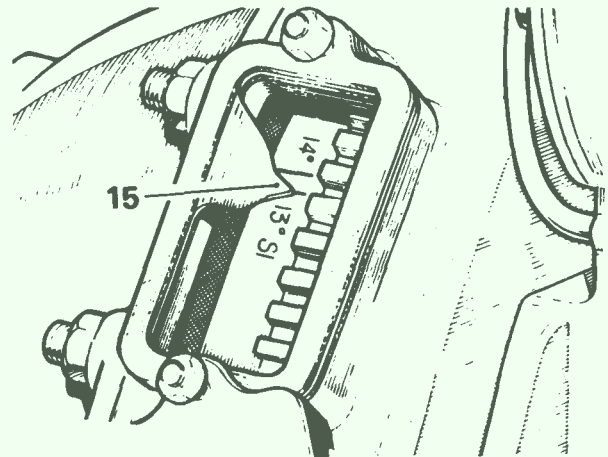

1123

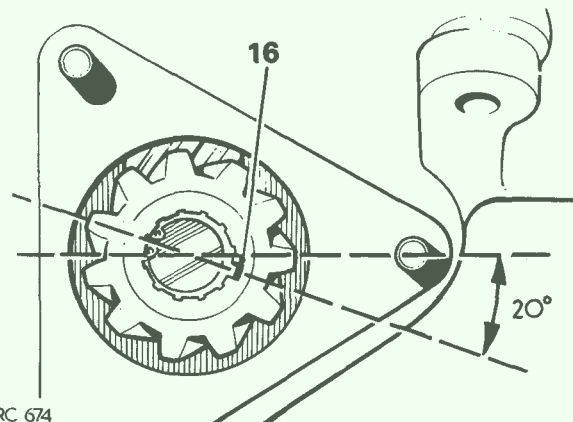

4RC 674

Continued

17. Using Service tool MS67B, assemble the scribing arm of the tool to the tool body.
18. Set gauge by loosening knurled screws and sliding bracket around until chamfered edge aligns with the required angle of 22°, tighten knurled screw in this position.
19. Insert tool MS67B into vacant injection pump position and engage tool gear into injection pump drive splines.
20. Release centre shaft retaining screw and slide tool body along centre shaft until body engages injection pump drive gear hub. Lock shaft retaining screw.
21. Apply gentle clockwise pressure to take up backlash or wear in gears, retain in this position.
22. Slacken off timing pointer bolts. Adjust timing pointer so that it aligns with scribing arm on tool. Tighten timing pointer bolts.
23. Remove tool MS67B.
24. Rotate driving gear on distributor pump so that master spline lines up with master spline on driving gear.
25. Then offer pump to engine, ensuring that the timing mark on the pump flange coincides with the timing pointer.
26. Tighten the injection pump retaining nuts.

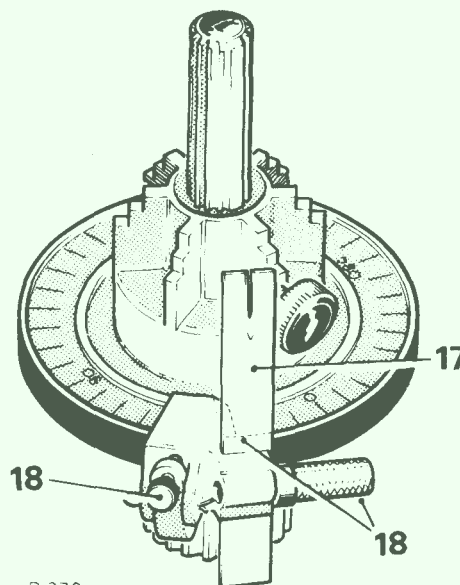

LR 372

NOTE: When the distributor pump is timed as detailed above, that is, with the timing pointer on the engine altered to take up backlash and wear on the gears, it ensures that optimum distributor pump timing is achieved. Should there be any fall-off of power during the life of the engine, retiming the distributor pump to take up gear wear could well make a significant improvement to engine performance, provided the engine is generally in good condition.

27. Reverse instructions 3 to 8 and 12 to 13.
28. Prime the fuel system 19.50.01.

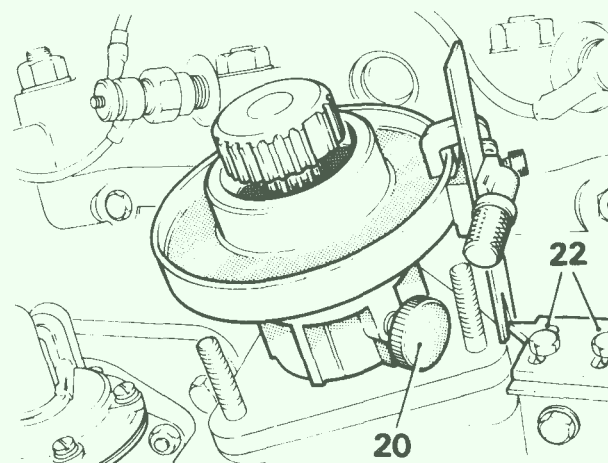

LR 373

Setting the distributor pump control screws

29. On distributor pumps with the maximum output control screw sealed, the control screw setting must not be altered. Adjustment is allowed to the slow running control screw only. However, when a new or reconditioned distributor pump is to be fitted, it will be found that the slow running control screw is loosely attached to the distributor pump and that the maximum output control screw is not sealed.
30. It is necessary, therefore, after the distributor pump has been assembled to the engine, first to fit the slow running control screw and then adjust both screws as detailed in items 31 to 36.

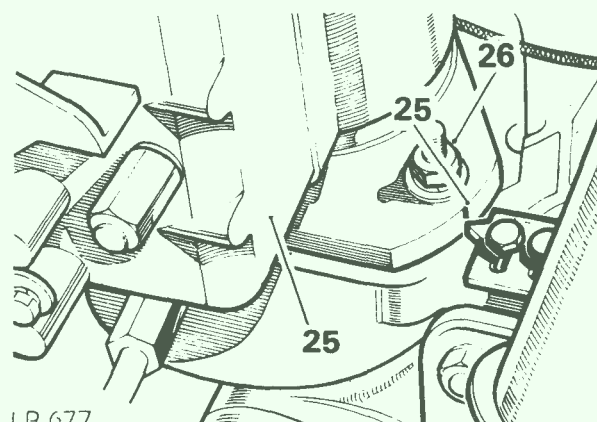

LR 677

Continued

FUEL SYSTEM

Slow running control screw adjusting

31. Adjust the control screw until the engine slow running speed is 590 ± 20 rev/min. This may be checked using a suitable revolution counter, or by adjusting the control screw until the lowest engine speed consistent with smooth, even running is achieved.
32. To adjust the slow running control screw, proceed as follows:
 - a. Check engine speed with revolution counter.
 - b. Slacken adjusting screw locknut and screw inwards to increase speed and outwards to decrease.
 - c. When a slow running speed of 590 ± 20 rev/min has been obtained, tighten locknut.
 - d. Remove revolution counter.

Maximum output control screw adjusting

33. Adjust the control screw, where necessary, until the engine maximum speed is 4200 ± 20 rev/min. This may be checked using a suitable revolution counter, or by road test; the road speed equivalent of 4,200 rev/min being 48 mph (77 kph) in third gear.
34. When maximum engine speed of $4,200 \pm 20$ rev/min has been obtained, tighten locknut.
35. Fit the adjusting screw collar.
36. Wire lock and seal the screw collar.
37. Reverse instructions 1 and 2.

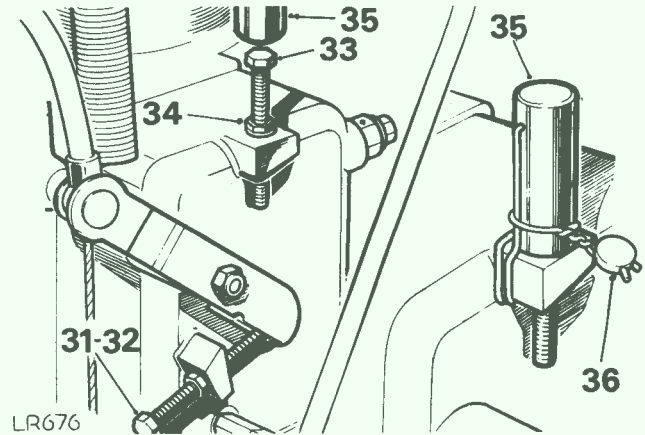

FUEL INJECTION PUMP

Altitude compensation for fuel injection pump

When vehicles equipped with diesel engines are operated at high altitude it is recognised that the reduced air density causes a reduction in the weight of air drawn into the engine cylinders, which results in incomplete combustion of the injected fuel at full throttle, unless this is reduced in proportion to the reduction in air density.

To compensate for these variations and to avoid excessive fuel consumption, accompanied by excessive exhaust smoke, the amount of fuel delivered to the cylinders must be reduced to suit the conditions under which the engine is required to operate, by de-rating the fuel pump delivery at a value of 3% per 330 metres (1,000 feet) of altitude operation.

It is recommended that vehicles intended for operation in high altitudes should have the injection pump adjusted by a C.A.V. dealer.

DATA

Injection timing setting
Idle speed
Maximum speed setting (sealed)

13° BTDC
 590 ± 20 rev/min
 $4,200 \pm 20$ rev/min

ELECTRICAL

OPERATIONS

CONTACT BREAKER POINTS (Ducellier)

—Remove and refit

86.35.13

Special tool 18G1308

Removing

1. Release the spring clips and remove the distributor cap.
2. Pull off the rotor arm.
3. Remove the dust shield.
4. Remove the retaining screw and remove the fixed contact point.
5. Slide the spring clip rearwards.
6. Disconnect the suppressor lead from the connector block.
7. Disconnect the lead from ignition coil.
8. Remove insulation washer from the moving contact point.
9. Lift off the moving contact point complete with leads and connector block from the distributor body.

Refitting

10. Fit the new moving point over post.
11. Locate the leaf spring in the plastic guide.
12. Fit the insulation washer.
13. Secure the assembly with the spring clip.
14. Fit the connector block to the distributor body.
15. Connect ignition coil lead.
16. Fit suppressor lead to connector block.
17. Fit the fixed contact point and loosely retain with the screw.

NOTE: The following two instructions describe the adjustment of the contact points. The accompanying illustration shows it being done with the aid of special tool 18G1308. Whilst the points can be adjusted to the datum setting only (see data) without the tool full distributor adjustment, i.e. dwell angle, dwell variation and vacuum advance can only be achieved by using this tool in conjunction with engine diagnostic equipment. It is essential that the above adjustments are carried out in order to maintain correct emission levels and maximum engine efficiency.

18. Rotate the engine until a cam of the rotor fully opens the points.
19. Using a feeler, adjust the position of the fixed contact point to the datum setting and tighten the retaining screw.
20. Check and adjust the dwell angle, dwell variation and vacuum advance, see instructions 38 to 43 operation 86.35.26.

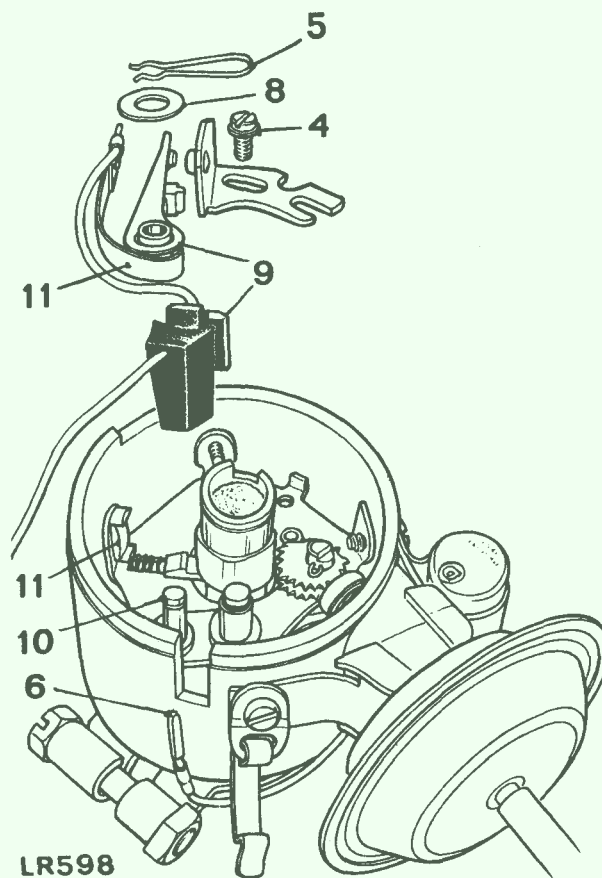

LR598

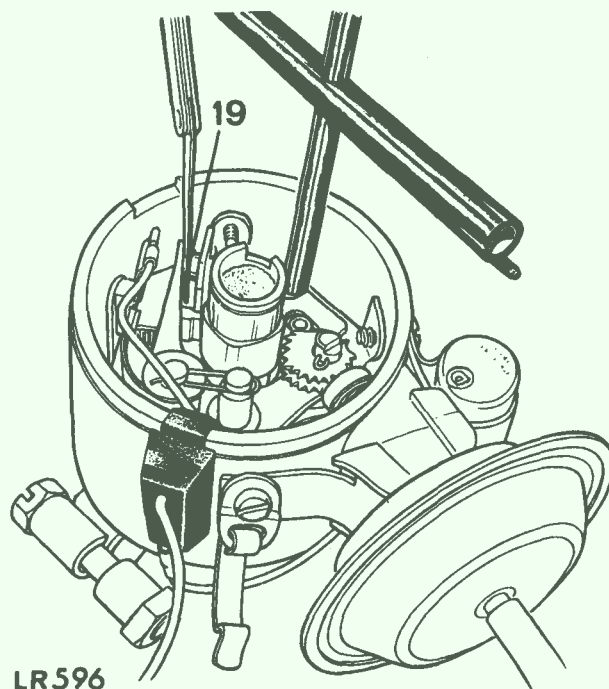

LR596

CONTACT BREAKER POINTS (Lucas Sliding Contact)

-Remove and refit

86.35.13

Removing

NOTE: The contact set should be renewed every 40,000km (25,000 miles).

1. Remove the distributor cap.
2. Remove the rotor arm.
3. Remove the retaining screw and lift the contact set complete from the plate.
4. Press the contact set spring and release the terminal plate and leads from the spring.

Refitting

5. Clean the points with petrol to remove the protective coating.
6. Press the contact spring and fit the terminal plate with the black lead uppermost.
7. Fit the contact set to the moving plate, ensuring that the peg, underneath the contact pivot, locates in the hole in the moving plate.
8. The sliding contact actuating fork must also locate over the fixed peg.
9. Loosely secure the assembly with the screw, plain and spring washer.
10. Check that the contact leaf spring locates properly in the insulation shoe.

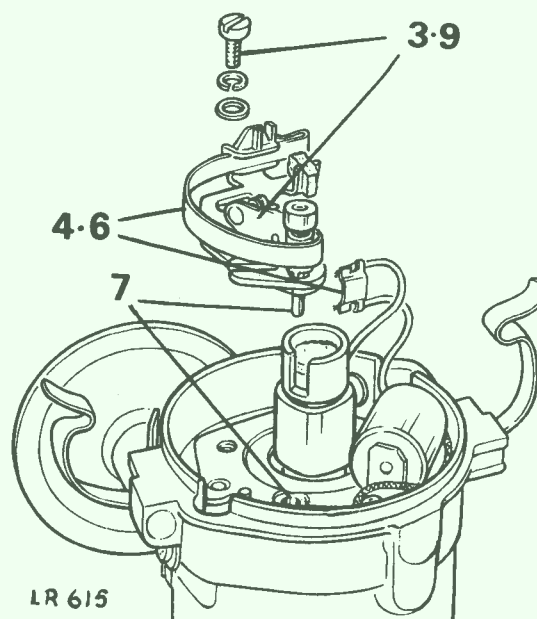

Adjusting the points gap

11. Rotate the crankshaft with the starting handle until the contact heel is on the highest point of a cam.
12. Adjust the gap by inserting a screwdriver blade between the 'V' shaped notch and pip and twist the screwdriver.
13. Insert a 0,35 to 0,40mm (0.014 to 0.016in.) feeler gauge between the points and adjust to a sliding fit and tighten the retaining screw.
14. Fit the rotor arm.

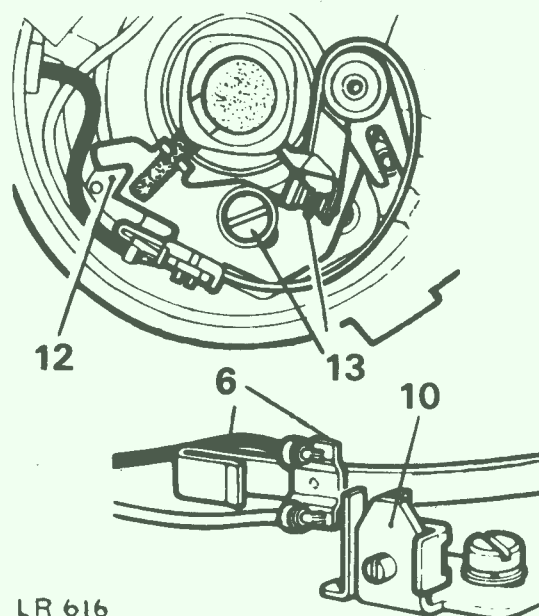

Continued

Lubrication

NOTE: The following instructions should be carried out every 20,000km (12,000 miles) except instruction 20.

15. Clean and lightly grease the cam with Shell Retinax or equivalent and remove any surplus lubricant.
16. Using the same grease lubricate the underside of the heel actuator.
17. Grease the actuator ramps and contact breaker heel ribs.
18. Apply grease to the fixed pin and the actuator fork.
19. Apply a drop of clean engine oil to the felt pad underneath the rotor arm.
20. Every 40,000km (25,000 miles) lubricate the automatic advance mechanism by injecting one or two drops of engine oil through the aperture in the base plate.
21. Wipe the internal and external surfaces of the distributor cap with clean dry nap-free cloth and fit the cap to the distributor body.

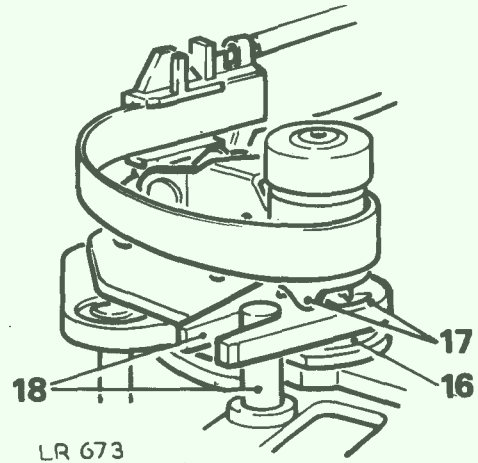
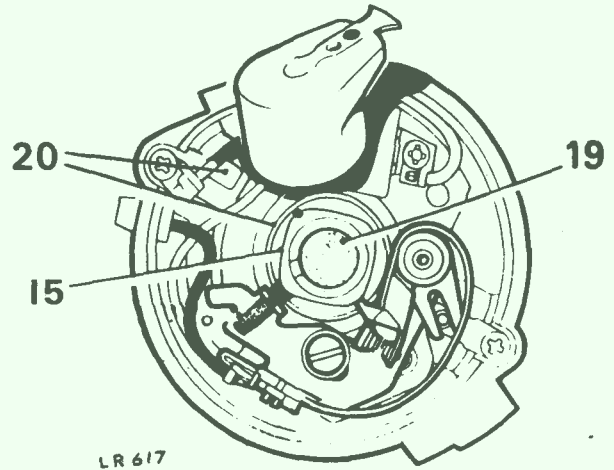

DISTRIBUTOR (Ducellier)

—Overhaul

86.35.26

Special tool 18G1308

Dismantling

1. Remove the distributor from the engine 86.35.20.
2. Remove the distributor cap.
3. Remove the rotor arm.
4. Remove the dust cover.
5. Remove the felt pad from the top of the rotor.
6. Remove the two screws retaining the condenser and vacuum unit and remove the condenser lead from the connector block.
7. Remove the retaining clip from the eccentric 'D' post.
8. Mark the position of the serrated cam in relation to the spring seat of the vacuum operating link.
9. Disengage the vacuum operating link and serrated cam from the eccentric 'D' post and remove the vacuum unit.
10. Remove the retaining screw and withdraw the fixed contact plate.
11. Remove the retaining clip and insulation washer.
12. Release the connector block from the distributor body.
13. Lift out the moving contact complete with connector block and leads.
14. Mark the relationship of the base plate to the body and remove the retaining screw. Whilst holding the pressure pad clear of the rotor, withdraw the base plate.
15. Remove the moving contact post-plate.

Inspection

NOTE: The distributor drive dog is loosely retained on the drive shaft, the "float" allows for any misalignment.

16. Examine the advance mechanism of the cam, check the shaft for excessive side play. If any of these parts are damaged or worn renew the complete distributor.
17. Examine all other components for damage or excessive wear and renew where necessary.
18. Check the distributor cover for signs of tracking or cracks and check that the pick-up brush moves freely in its holder.
19. Check the rotor arm for damage, electrode security, burning and tracking.

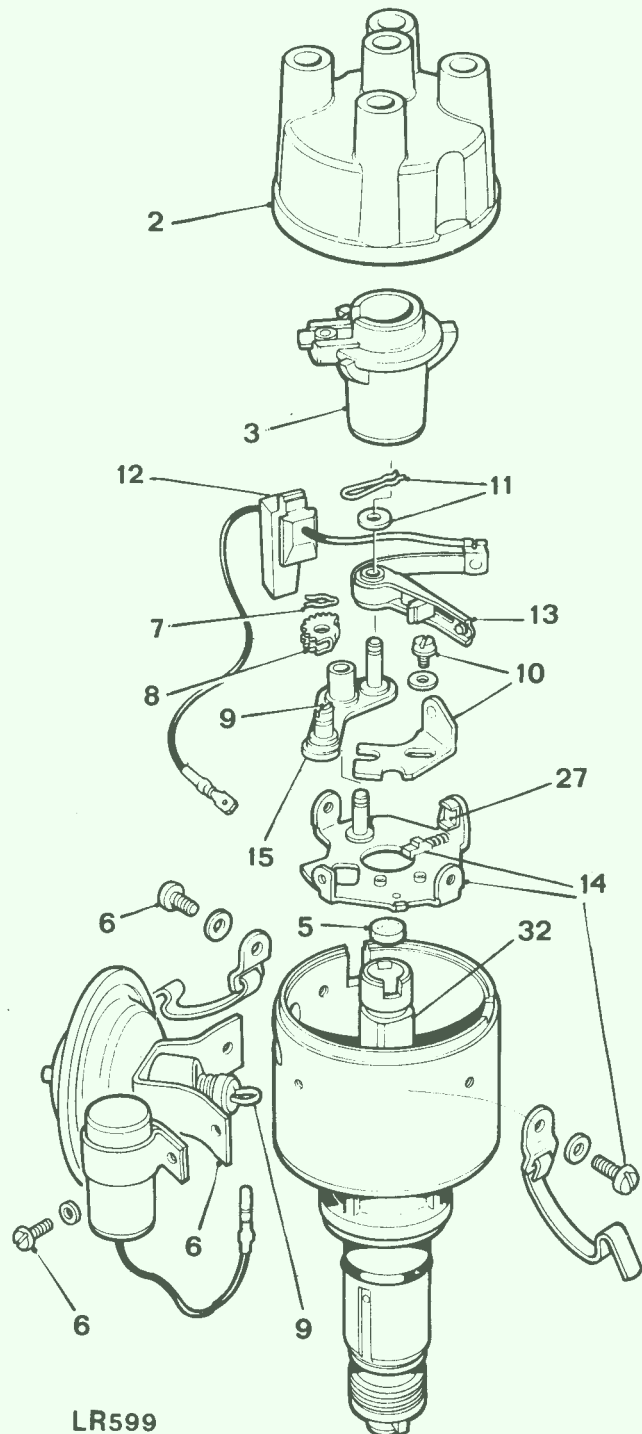
*Continued*

Reassembling

20. Using Retinax 'A' or equivalent grease lubricate the centrifugal weight pivot posts and lightly smear the cam pressure pad and contact pivot post.
21. Fit the pressure pad and spring to the base plate.
22. Fit the base plate to the body, lining up the marks, and secure with the retaining screw and clip on the opposite side to the vacuum unit.
23. Smear a little grease on the post and fit the moving contact post-plate to the base plate.
24. Offer up the vacuum unit to the body and fit the operating link and serrated cam to the 'D' post. Ensure that the identification marks line up – see instruction 8. Secure the assembly with the spring clip.
25. Secure the vacuum unit and condenser to the body with the remaining screw and clip.
26. Fit the fixed contact and loosely retain with the screw.
27. Fit the moving contact ensuring that the leaf spring locates in the nylon guide.
28. Fit the connector block to the body.
29. Fit the insulation washer and retain assembly with the spring clip.
30. Fit condenser lead to connector block.
31. Place the felt pad in the top of the rotor and add a few drops of oil.
32. Smear a small quantity of grease on the rotor cam.
33. Adjust the contact point gap to a datum setting of 0,43mm (0.017in.) with a feeler gauge by turning the rotor spindle until a cam fully opens the points. Move the fixed contact plate to obtain the required gap and tighten the retaining screw.
34. Fit the distributor to the engine, see operation 86.35.20.
35. Fit the dust cover.
36. Fit the rotor arm and distributor cap.
37. Connect the H.T. leads to the appropriate spark plugs.

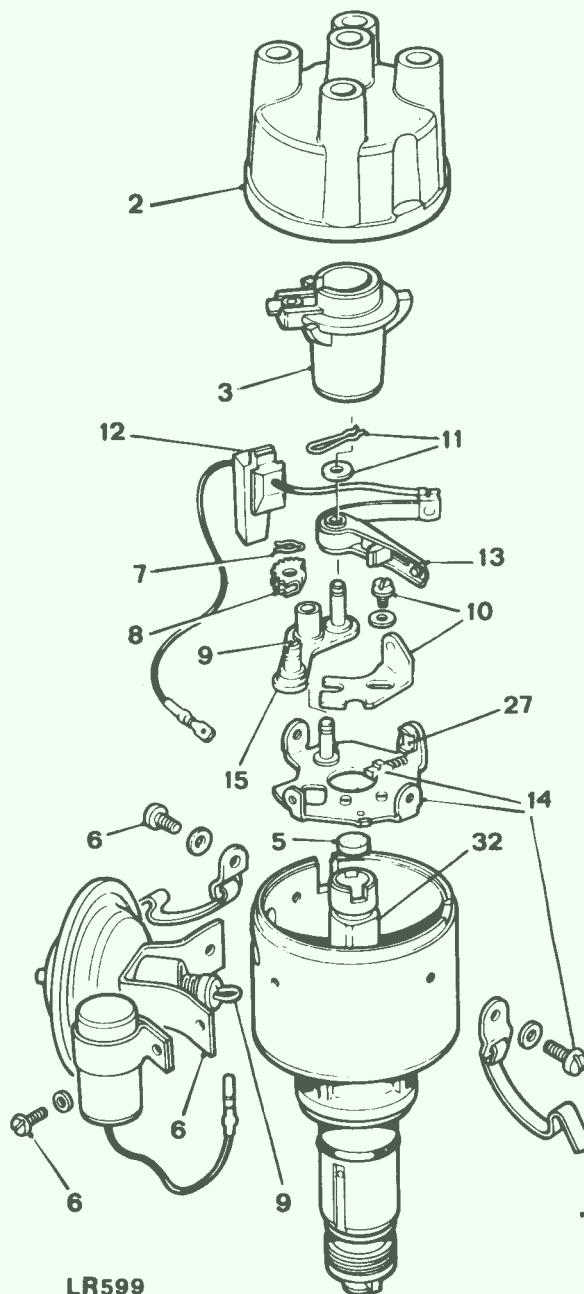

Continued

Check and adjust dwell angle

NOTE: The following six instructions can only be carried out using engine diagnostic equipment and special tool 18G1308.

38. Start the engine, disconnect the vacuum pipe from the vacuum unit and with the engine idling check the dwell angle – see data. If adjustment is required stop the engine, remove the distributor cap, rotor arm and dust cover, slacken the fixed contact retaining screw and using the eccentric-post end of the special tool, as illustrated, make an appropriate adjustment. Tighten the retaining screw, reassemble the distributor and recheck the dwell angle.

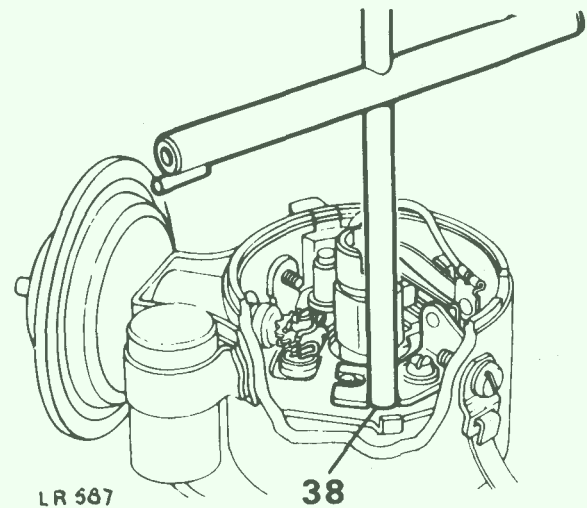

LR 587

38

Check and adjust dwell variation

NOTE: A dwell variation outside the accepted tolerance – see data can be caused by a mechanical fault or wear within the distributor. This may be checked as follows:

39. Disconnect the vacuum advance, start the engine and increase the speed to 2000 r.p.m. A variation outside the tolerance given in data indicates that the distributor has a mechanical fault which cannot be rectified by adjustment.
40. If the variation is acceptable, reconnect the vacuum pipe, start the engine and increase the engine speed to 2,000 rpm and release the throttle. Check the dwell variation and if necessary adjust by turning the eccentric 'D' post with the special tool (female 'D' end). Setting the dwell for minimum variation may alter the basic setting and this must be rechecked at idle speed.

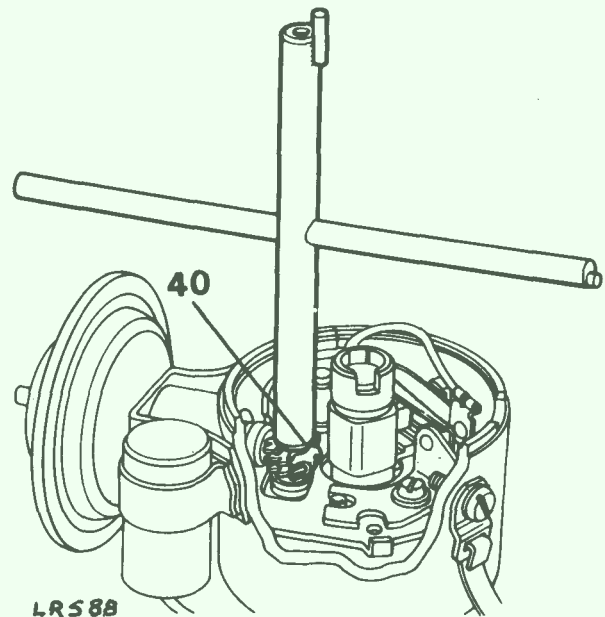

LR 588

40

Check the vacuum advance

NOTE: If the vacuum unit has been removed or the distributor dismantled, the vacuum advance must be checked and if necessary adjusted.

41. Disconnect the vacuum pipe and connect a vacuum pump to the unit.
42. Start and run the engine at idle speed and using a timing light, slowly increase the vacuum and note the point at which vacuum advance starts and compare the figure with that given in data.
43. Adjustment of the serrated cam, with the special tool, one tooth at a time, will alter the point at which vacuum advance starts.

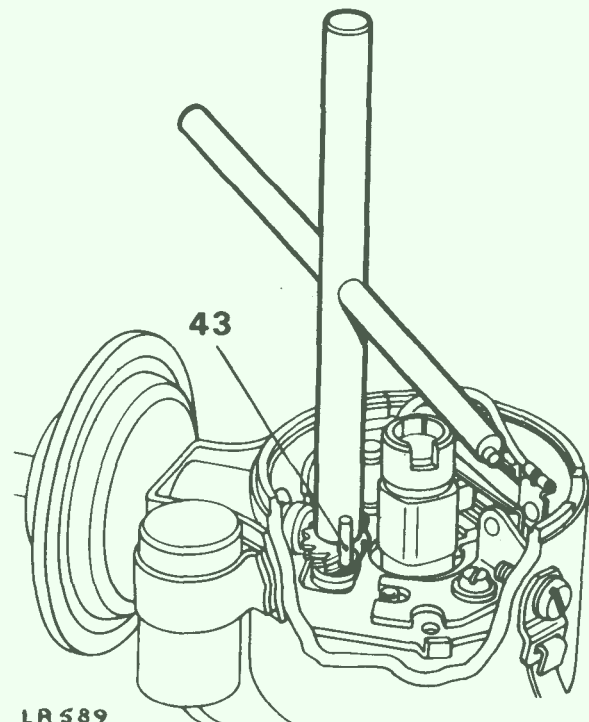

LR 589

43

Continued

ELECTRICAL

DATA

Rotation	Anti-clockwise at rotor end
Contact points gap (datum figure only)	0,43mm (0.017in.)
Dwell angle	57°
Dwell variation	± 2° 30'
Vacuum advance starts	102mm (4in.) HG
Vacuum advance max.	12° at 457mm (18in.) HG
No centrifugal advance below	900 rev/min