



**88"  
WHEELBASE  
REGULAR**





Land-Rovers have been travelling the roads and working the rough lands of the world for over twenty-one years. Today, they still lead the field in virtually every aspect of 4-wheel drive operation. Outwardly, the Land-Rover has changed little in ten years, simply because its practical design and rugged construction are best suited to the enormous diversity of jobs it is called upon to do. Mechanically, however, a great many developments have progressively taken place to improve the breed and keep pace with the special and ever-growing needs of operators throughout the world. The modern Land-Rover in all its versions represents an important advance over its counterparts of only a few years ago. It is now, more than ever, "The World's Most Versatile Vehicle", carrying on its legendary service across 182 countries.

Some of the illustrations in this catalogue show vehicles fitted with optional extras. For full details of extras available see separate publication.



1



6



11



2



7



12



3



8

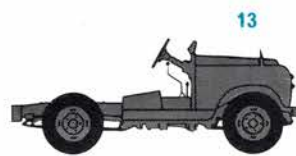

13



4

1. Basic model with full-length canvas hood.
2. Full-length hood with side windows for export.
3. Hardtop with tailboard and top hinged flap.
4. Hardtop with side-opening rear door.
5. Hardtop with tailboard, top hinged flap and fixed side windows for export.
6. Hardtop with rear door and fixed side windows for export.
7. Hardtop with tailboard,

- top hinged flap and sliding side windows for export.
8. Hardtop with rear door and sliding side windows for export.
9. Cab and three-quarter length hood with side windows for export.
10. Cab and three-quarter length hood.
11. Cab and open body.
12. Chassis/cab with bonnet and wings.
13. Chassis/scuttle with bonnet and wings.



5



9



10

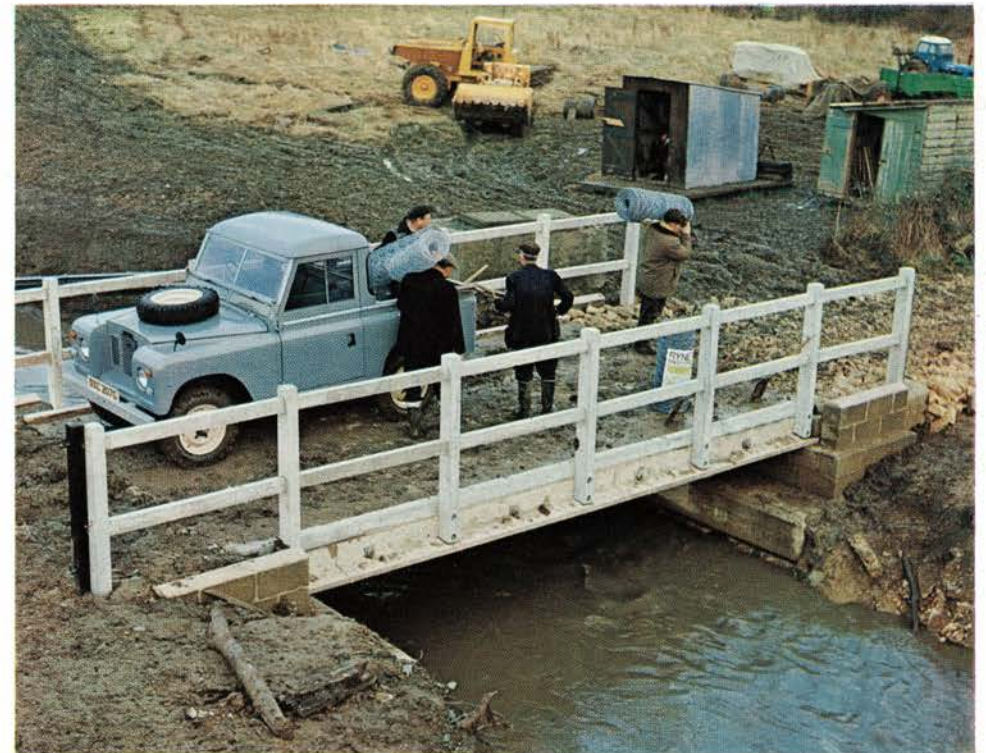









*De-luxe seats can be supplied as an optional extra to give greater comfort and support.*

The front compartment has high-visibility seating accommodation for driver and two passengers. Instruments and switches are grouped centrally and

include a water temperature gauge and combined ignition/starter switch. An extended handbrake lever ensures ease of application by a driver wearing safety harness. Heating, de-luxe seats and other cab refinements can be provided as optional extras.

The rear body space will take almost any kind of load up to a limit of 1,000 lb. (454 kg.) on roads, or 800 lb. (363 kg.)



across rough country. Its aluminium alloy construction is non-rusting and anti-corrosive, permitting the carriage of manures, fertilizers and other similar substances. Folding rear seats, shown above, can be supplied as optional extras.



The box section chassis frame with its sturdy cross-members provides an immensely strong foundation for the Regular Land-Rover. It is built to withstand the constant shocks of cross-country operation and being painted both inside and out is resistant to rust and corrosion over long periods of use. Individual components are equally robust and the whole unit combines good ground clearance with a low centre of gravity to minimise "grounding" and give stability on steep slopes. Right- or left-hand steering is offered.



#### TRANSMISSION

Two- or four-wheel drive. Main gearbox has four forward speeds and one reverse, with synchromesh on third and top. Two additional ratios are provided in the transfer box giving a total of eight forward and two reverse speeds. This wide choice of ratios enables all kinds of surfaces to be traversed. Front and rear axles are fully-floating and have spiral bevel drive.



#### CHASSIS FRAME

Welded steel box-section of great strength. Six cross-members give torsional and diagonal rigidity.



#### BRAKES

Hydraulic. Handbrake operates transmission brake behind transfer box.



#### ENGINES

Choice of two units: four-cylinder, 2½-litre petrol or four-cylinder, 2½-litre diesel.



#### SUSPENSION

Underslung semi-elliptic springs controlled by double-acting hydraulic telescopic shock absorbers.



#### POWER TAKE-OFF

Provision for centre and rear power take-off drives. Hydraulic or capstan winch may be fitted at front.



#### BODY

Steel fittings, including bulk-head and front grill surround, are either treated and painted or heavily galvanised. All body panels are of non-corrodible light alloy.

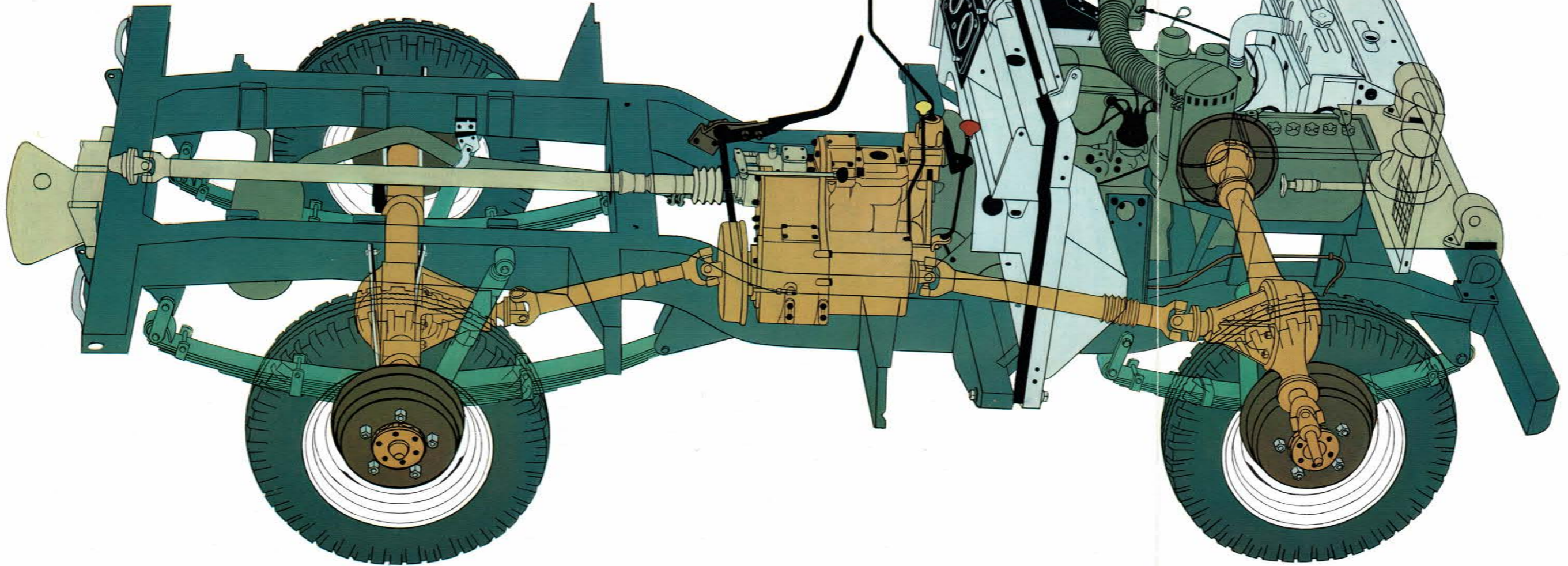



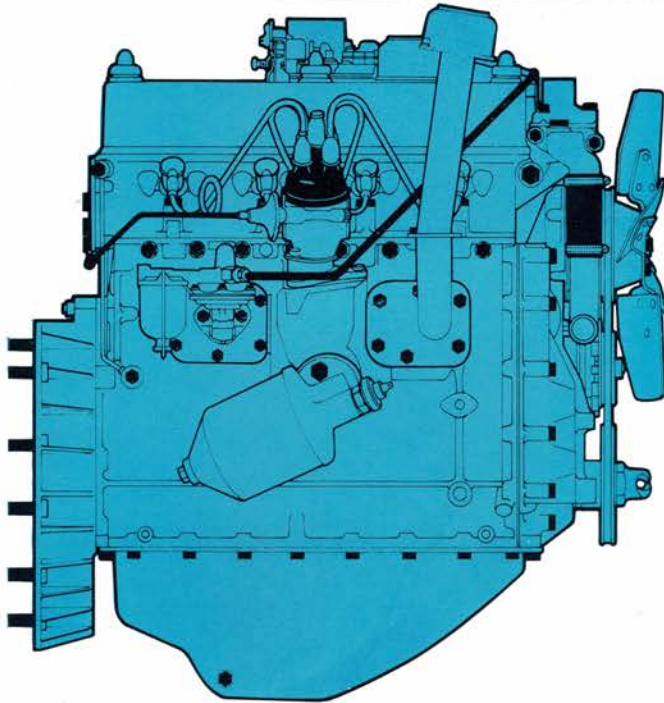

### **PETROL ENGINE**

Of overhead valve design, the four-cylinder 2¼-litre petrol engine develops 81 b.h.p. (gross) at 4,250 rev./min. and has a torque of 127 lb. ft. at 2,500 rev./min. Thus, there is ample power available for vehicle operation under all conditions, hauling trailers or driving machinery. It is a well-proved unit of outstanding reliability that has powered millions of Land-Rover miles.

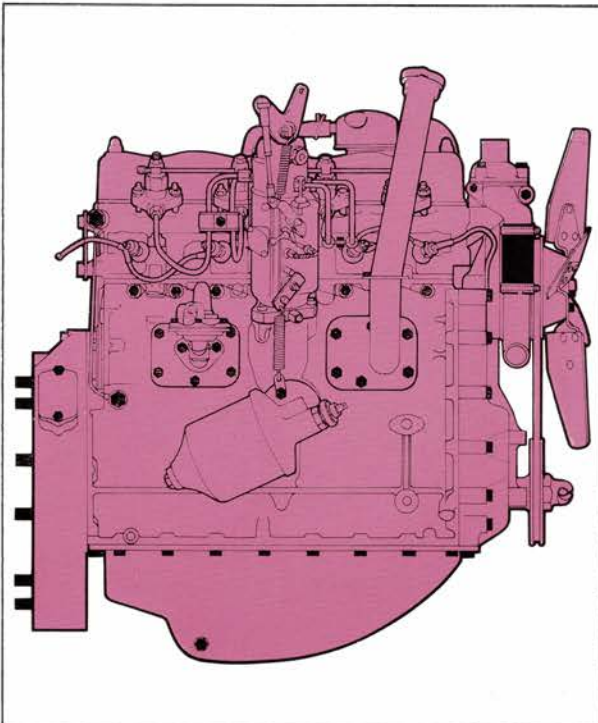

### **DIESEL ENGINE**

A 2¼-litre diesel engine is available as an alternative to the petrol engine and adds further to the versatility of the Land-Rover by increasing its efficiency and economy in conditions favouring diesel operation. A rugged, four-cylinder unit, the Rover diesel engine develops 67 b.h.p. at 4,000 rev./min., and maximum torque of 105 lb. ft. is produced at 1,800 rev./min.



LOG 292 F

DXC 203G

LAND ROVER



# SPECIFICATION

## FUEL SYSTEM

Carburettor	..	Zenith down-draught type 36 I.V.
Filters	..	Tank, paper element.
Air cleaner	..	Oil bath with built-in centrifugal pre-cleaner.
Pump	..	Mechanical, with sediment bowl and priming lever.

## ELECTRICAL SYSTEM

Ignition	..	By coil and distributor.
Starter	..	Operated by combined ignition/starter switch key and solenoid.

## 4-CYLINDER DIESEL

No. of cylinders	..	4.
Bore	..	3.562" (90.47 mm.).
Stroke	..	3.5" (88.9 mm.).
Capacity	..	2,286 c.c. (139.5 cu. in.).
Valve position	..	Overhead.
Compression ratio	..	23 : 1.
Max. B.H.P.	..	67 at 4,000 rev./min. (Gross).
Max. Torque	..	105 lb. ft. (14.5 Kg.m.) at 1,800 rev./min. (Gross).

## LUBRICATION SYSTEM

Type	..	Pressurised by submerged gear type pump.
Filters	..	Pump intake gauze-filter in sump, and external full flow filter.
Sump capacity	..	11 pints (13 U.S. pints; 6 litres).

## COOLING SYSTEM

Type	..	Pressurised, with pump, fan and thermostat.
Capacity	..	17½ pints (21 U.S. pints; 10 litres).

## FUEL SYSTEM

Injector pump	..	C.A.V., D.P.A. distributor type, self-governing.
Injector type	..	C.A.V. Pintaux.
Filters	..	Sediment bowl on mechanical fuel pump. Paper type filter. Fuel tank.
Air cleaner	..	Oil bath with built-in centrifugal pre-cleaner.
Fuel pump	..	Mechanical, with hand primer (high pressure type).

## ELECTRICAL SYSTEM

Starter	..	Operated by key switch and solenoid.
Heater plugs	..	Coil element, 1.7 volts 36/42 amps. Operation—combined with starter switch key.

## TRANSMISSION

CLUTCH		
Type	..	2½ L. petrol. Single dry plate, 9" (230 mm.) diameter. Multi-coil spring type.
	..	2½ L. diesel. Single dry plate, 9½" (241 mm.) diameter. Diaphragm spring type.
Operation	..	Hydraulic.

## MAIN GEARBOX

Type	..	Single helical constant mesh with synchromesh on top and third speeds.
Oil capacity	..	2½ pints (3 U.S. pints; 1.5 litres).

## TRANSFER GEARBOX

Type	..	Two-speed reduction on main gearbox output.
Four wheel drive	..	Two/four wheel drive control on transfer box output.
Oil capacity	..	4½ pints (5½ U.S. pints; 2.5 litres).

## PROPELLER SHAFTS

Type	..	Open, to front and rear axles.
------	----	--------------------------------

## REAR AXLE

Type	..	Spiral bevel; floating shafts.
Ratio	..	4.7 : 1.

Oil capacity .. 3 pints (3½ U.S. pints; 1.7 litres).

## FRONT AXLE

Type	..	Spiral bevel; floating shafts.
Ratio	..	4.7 : 1.
Oil capacity	..	Differential, 3 pints (3½ U.S. pints; 1.7 litres). Universal joint housing, 1 pint (1¼ U.S. pints; 0.57 litres).

## OVERALL RATIOS (Final Drive)

	High Transfer	Low Transfer
Top ..	5.4 : 1	11.1 : 1
Third ..	8.05 : 1	16.5 : 1
Second ..	12.0 : 1	24.6 : 1
First ..	19.4 : 1	39.7 : 1
Reverse ..	16.3 : 1	33.2 : 1

## POWER TAKE-OFF POINTS

Central, bottom and rear power take-off drives available as optional extras.

## CHASSIS DETAILS

### FRAME

Type	..	Welded fabricated box section side and cross members, black enamel dipped.
------	----	--

## ENGINES

### 4-CYLINDER PETROL

No. of cylinders	..	4.
Bore	..	3.562" (90.47 mm.).
Stroke	..	3.5" (88.9 mm.).
Capacity	..	2,286 c.c. (139.5 cu. ins.).
Valve position	..	Overhead.
Compression ratio	..	8 : 1.
Max. B.H.P.	..	81 at 4,250 rev./min. (Gross).
Max. Torque	..	127 lb. ft. (17.5 Kg.m.) at 2,500 rev./min. (Gross).

## LUBRICATION SYSTEM

Type	..	Pressurised by submerged gear type pump.
Filters	..	Pump intake gauze filter in sump, and external full flow filter.
Sump capacity	..	11 pints (13 U.S. pints; 6 litres).

## COOLING SYSTEM

Type	..	Pressurised, with pump fan and thermostat.
Capacity	..	18 pints (21½ U.S. pints; 10.25 litres).

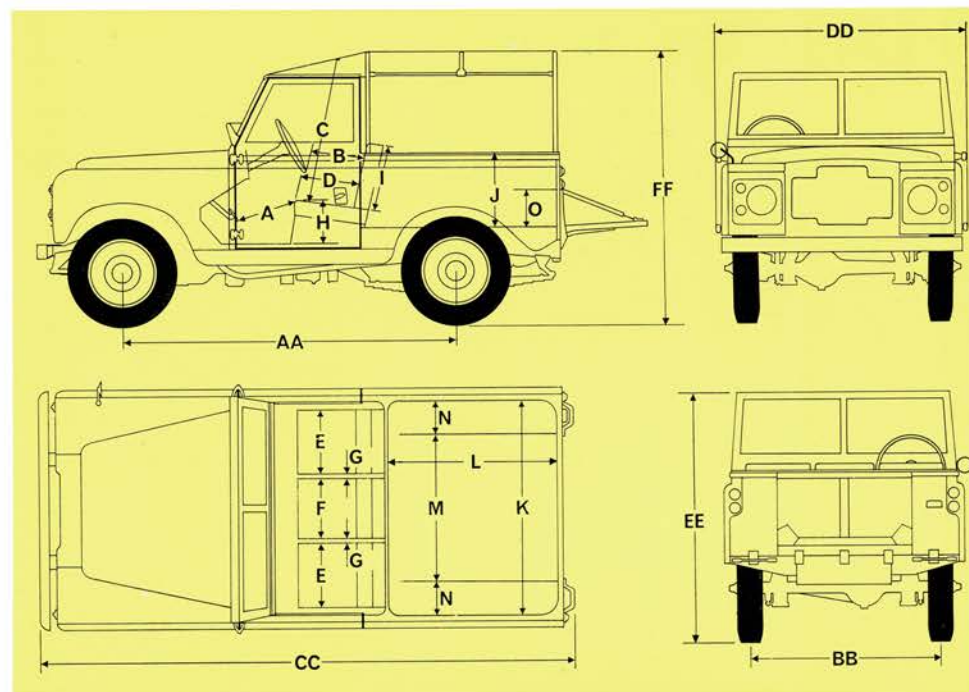



Front bumper .. Channel section, galvanised.

### SUSPENSION

Road springs .. Semi-elliptic, underslung.  
Shock absorbers .. Hydraulic double acting telescopic.

### STEERING

Type .. .. Recirculating ball, worm and nut.  
Steering wheel diameter—17" (43·18 cm.).  
Turning circle (with 6·00"×16" tyres)—38 ft. (11·6 m.) diameter.  
Number of turns, lock to lock—3½.

### BRAKES

Foot brake .. Hydraulic drum brakes with leading and trailing shoes. 1½" wide.  
Hand brake .. Mechanical internal expanding drum brake on transfer box output.

### WHEELS AND TYRES

Wheel type .. Ventilated disc.  
Wheel size .. 5·00" F×16".  
Standard tyre and tube size .. 6·00"×16".  
Standard tread .. Dual-purpose (road and cross-country).

### DIMENSIONS

		Ins.	Metres
AA	Wheelbase .. .. .	88·00	2·23
BB	Track .. .. .	52·50	1·33
CC	Overall length .. .. .	142·563	3·62
DD	Overall width (over hinges)	66·00	1·68
EE	Overall height of windscreen	67·50	1·714
FF	Overall height with hood ..	77·50	1·97
—	Ground clearance .. .. .	7·00	0·178
A	Front cushion to accelerator pedal .. .. .	19·25	0·489
B	Front squab to steering wheel .. .. .	14·50	0·368
C	Headroom, front seat (uncompressed) .. .. .	38·00	0·965
D	Front to rear of front cushion .. .. .	15·75	0·400
E	Width of front cushion ..	18·00	0·457
F	Width of front centre cushion .. .. .	15·00	0·381
G	Width between front seats	1·00	0·025
H	Top of front cushion to floor	14·25	0·362
I	Front squab height .. .. .	17·75	0·451
J	Height of body sides .. .. .	20·00	0·508
K	Width of body interior ..	57·00	1·448
L	Length of body interior ..	47·50	1·206
M	Interior body width between wheel boxes .. .. .	36·25	0·921
N	Width of wheel boxes .. .. .	11·50	0·292
O	Height of wheel boxes .. ..	8·50	0·216

### FUEL SYSTEM

Fuel tank .. .. Carried outside side member under right-hand seat. Fitted with protective under-plate, and telescopic external filler tube.  
Capacity .. .. 10 gallons (12 U.S. gallons; 45 litres).

### CHASSIS OPTIONAL EQUIPMENT

Includes .. .. Extra instruments, 12 volt alternator, winches, towing equipment, special protective devices, and special purpose tyres. See separate publication for details.

### ELECTRICAL EQUIPMENT AND INSTRUMENTATION

#### ELECTRICAL SYSTEM

Type .. .. Negative earth.  
Voltage .. .. 12 volt. Diesel—two 6 volt batteries in series.

#### ELECTRICAL EQUIPMENT

Battery .. .. Petrol—58 A.H. Diesel—120 A.H.  
Generator .. .. Fan ventilated dynamo, 22 amperes output. Compensated voltage control—petrol. Current voltage control—diesel.

Windscreen wiper .. Dual arm.  
Horn .. .. Windtone. Horn push in centre of steering wheel.

#### INSTRUMENTS AND CONTROLS

Speedometer .. Large diameter with total mileage recorder including oil pressure, headlamp main beam and cold start warning lights.

Water temperature and fuel gauges .. Combined in one large dial which also includes the charging warning light.

Panel Light .. Illuminating speedometer, water temperature and fuel gauges. Switch operates when side and tail lamps are "on".

Petrol model .. Ignition switch. Operated by key.  
Toggle switch for head, side and tail lamps.  
Ignition warning light: red.  
Choke warning light: amber.  
Oil pressure warning light: green.  
Headlamp main beam warning light: blue.

Diesel model .. Lighting switch: toggle switch for head, side and tail lamps.  
Heater/starter/auxiliary switch: operated by key.  
Engine stop control: located on dash.  
Charging warning light, red. Heater plug warning light: amber. Oil pressure warning light: green. Headlamp main beam warning light: blue. Fuel tank level warning light: blue.  
Engine speed hand control.

Lighting .. .. Headlamps — mounted in front wings.  
Side lamps — mounted in front wings.  
Tail lamps — Twin units having double filament stop/tail bulbs and incorporating numberplate illumination.  
Dip switch — mounted on floor.

### BODY

#### CONSTRUCTION

All body panels are of non-corrosive light alloy, and all external steel fittings are heavily galvanised.

#### OPTIONAL EQUIPMENT

Includes alternative hood, hardtop and rear door arrangements, seats, trim, heater, and various interior equipment. See separate booklet for details.

#### COLOURS

In the colour schemes shown below the colours marked \* are standard, while those marked † are optional and subject to an extra charge. Variations in body colours are possible for particular requirements in regard to fire appliances and special fleet customer specifications. Quotations may be obtained from the factory on request.

Body Colour	Road Wheels	Home	Export
Bronze green	Bronze green	*	*
Sand	Limestone	†	*
Light Green	Limestone	*	*
Marine blue	Limestone	*	*
Limestone	Limestone	*	*
Mid grey	Limestone	*	*
Dark grey	Limestone	†	†
Red	Red	†	†
Mist coat grey	Primer	*	*

Trim	Colour	Home	Export
Interior trim & seats	Black	*	*
Interior trim & seats	Red	Fire Engines only	
Roof interior lining	White	*	*
Canvas hood	Khaki	*	*
Canvas hood	Blue	*	*

### CONSTANTS WITH ALL COLOUR SCHEMES

Tropical roof Hard top Chassis frame	Limestone Limestone Black
--	---------------------------------

### PERFORMANCE

#### PAYLOADS

Road work .. 3 persons plus 1,000 lb. (454 kg.).  
Cross country .. 3 persons plus 800 lb. (363 kg.).

#### WEIGHTS

Petrol Engine	Front Axle lb. kg.	Rear Axle lb. kg.	Total lb. kg.
Unladen, plus 5 galls. fuel	1,640 744	1,313 595	2,953 1339
Max. allowable gross weight, normal road work	1,828 830	2,625 1190	4,453 2020
Cross country, standard road springs .. .. .	1,828 830	2,425 1100	4,253 1930
Diesel Engine			
Unladen plus 5 galls. fuel	1,730 785	1,367 620	3,097 1405
Max. allowable gross weights, normal road work .. .. .	2,140 970	2,625 1190	4,765 2160
Cross country, standard road springs .. .. .	2,140 970	2,425 1100	4,565 2070

#### MAX. DRAWBAR PULL

Petrol .. .. 4,000 lb. (1800 kg.).  
Diesel .. .. 3,300 lb. (1497 kg.).

#### GRADIENT

Unladen .. .. .	Petrol 45°	Diesel 45°
Laden .. .. .	Petrol 37°	Diesel 30°





By appointment to Her Majesty Queen Elizabeth II  
Manufacturers of Motor Cars and Land-Rovers  
The Rover Company Limited

# THE ROVER COMPANY LIMITED

## SOLIHULL · WARWICKSHIRE · ENGLAND

Telephone: 021-743 4242

Telegrams: Rover, Solihull

Telex: 33-156

*The Rover Company Limited reserves the right to alter specifications, colour, designs or prices without notice and without incurring any obligation. While every effort is made, in Rover literature, to provide information that is strictly up to date no responsibility can be accepted for such alterations that occur after date of going to press. Persons dealing in the Company's goods are not the agents of the Company and have no authority whatsoever to bind the Company by any expressed or implied undertaking. Sales are conditional upon terms of business, warranties and service arrangements issued by The Rover Company Limited.*



THE QUEEN'S AWARD  
TO INDUSTRY 1966

For Long, Station Wagon, Forward Control and 1-Ton Models see Publications numbered 756, 757, 707 and 764 respectively.